

PLEASE CHECK WWW.MOLEX.COM FOR LATEST PART INFORMATION

Part Number: [0190020040](#)
Status: **Active**
Description: Avikrimp™ Fully Insulated Quick Disconnect, Female, for 14-16 AWG Wire, Box

Documents:

[Drawing \(PDF\)](#) [RoHS Certificate of Compliance \(PDF\)](#)

Agency Certification

UL E79133

General

Product Family Quick Disconnects
 Series [19002](#)
 Crimp Quality Equipment Yes
 Product Name Avikrimp™
 Type Quick Disconnect

Physical

Barrel Type Closed
 Flammability 94V-2
 Gender Female
 Glow-Wire Compliant No
 Insulation Nylon (PA)
 Lock to Mating Part None
 Material - Metal Brass
 Orientation Straight
 Packaging Type Bag
 Polarized to Mating Part No
 Tab Thickness 0.51mm (.020")
 Tab Width 5.21mm (.205")
 Temperature Range - Operating -65°C to +105°C
 Wire Insulation Diameter 3.94mm (.155") max.
 Wire Size AWG 14, 16
 Wire Size mm² 1.30 - 2.00

Electrical

Voltage - Maximum 300V

Material Info

Old Part Number BB-5287

Reference - Drawing Numbers

Sales Drawing SD-19002-004

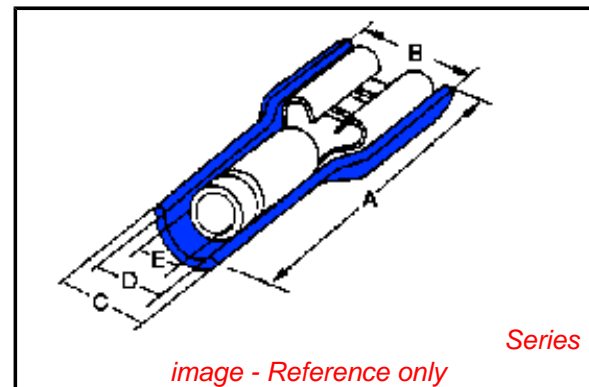

EU RoHS

**ELV and RoHS
Compliant**
REACH SVHC
 Not Reviewed
**Halogen-Free
Status**

China RoHS



Not Reviewed

**Need more information on product
environmental compliance?**

Email productcompliance@molex.com
 For a multiple part number RoHS Certificate of Compliance, [click here](#)

Please visit the [Contact Us](#) section for any non-product compliance questions.

Search Parts in this Series

[19002Series](#)

Application Tooling | [FAQ](#)

Tooling specifications and manuals are found by selecting the products below. Crimp Height Specifications are then contained in the Application Tooling Specification document.

Global

Description	Product #
Hand Crimp Tool	0640011100
Crimp Head for the AT-200™ Pneumatic Hand Tool	0640051100

13	12	11	10	9	8	7	6	5	4	3	2	1		
MATERIAL NUMBER LOOSE PCS	ENGINEERING NUMBER LOOSE PCS	MATERIAL NUMBER ON STRIP	ENGINEERING NUMBER ON STRIP	MATERIAL NUMBER ON TAPE	ENGINEERING NUMBER ON TAPE	MATERIAL NUMBER REVERSE WOUND	ENGINEERING NUMBER REVERSE WOUND	ACCEPTS TAB SIZE	STOCK THICKNESS	"A" MAX	"B" MAX	"F" REF	"G" MAX	"H" REF
190020024	BB-5263	190020027	BB-5263Z	190020025	BB-5263T	190020026	BB-5263TR	.250x.032 (6.35x0.81)	.016/0.41	.89/22.6	.38/9.7	.16/4.1	.20/5.1	1.425/36.20
190020040	BB-5287	190020041	BB-5287Z	190020048	BB-5287T	---	---	.205x.020 (5.21x0.51)	.016/0.41	.80/20.3	.32/8.1	.16/4.1	.22/5.6	1.415/35.94
190020042	BB-5289	190020061	BB-5289Z	190020043	BB-5289T	---	---	.205x.032 (5.21x0.81)	.016/0.41	.80/20.3	.32/8.1	.16/4.1	.22/5.6	1.415/35.94
190020028	BB-5269	190020030	BB-5269Z	190020029	BB-5269T	---	---	.187x.020 (4.75x0.51)	.016/0.41	.80/20.3	.32/8.1	.16/4.1	.22/5.6	1.415/35.94
190020031	BB-5273	190020033	BB-5273Z	190020032	BB-5273T	---	---	.187x.032 (4.75x0.81)	.016/0.41	.80/20.3	.32/8.1	.16/4.1	.22/5.6	1.415/35.94
190020034	BB-5277	190020036	BB-5277Z	190020035	BB-5277T	---	---	.110x.020 (2.79x0.51)	.012/0.31	.80/20.3	.23/5.8	.13/3.3	.22/5.6	1.395/35.43
190020037	BB-5281	190020039	BB-5281Z	190020038	BB-5281T	---	---	.110x.032 (2.79x0.81)	.012/0.31	.80/20.3	.23/5.8	.13/3.3	.22/5.6	1.395/35.43

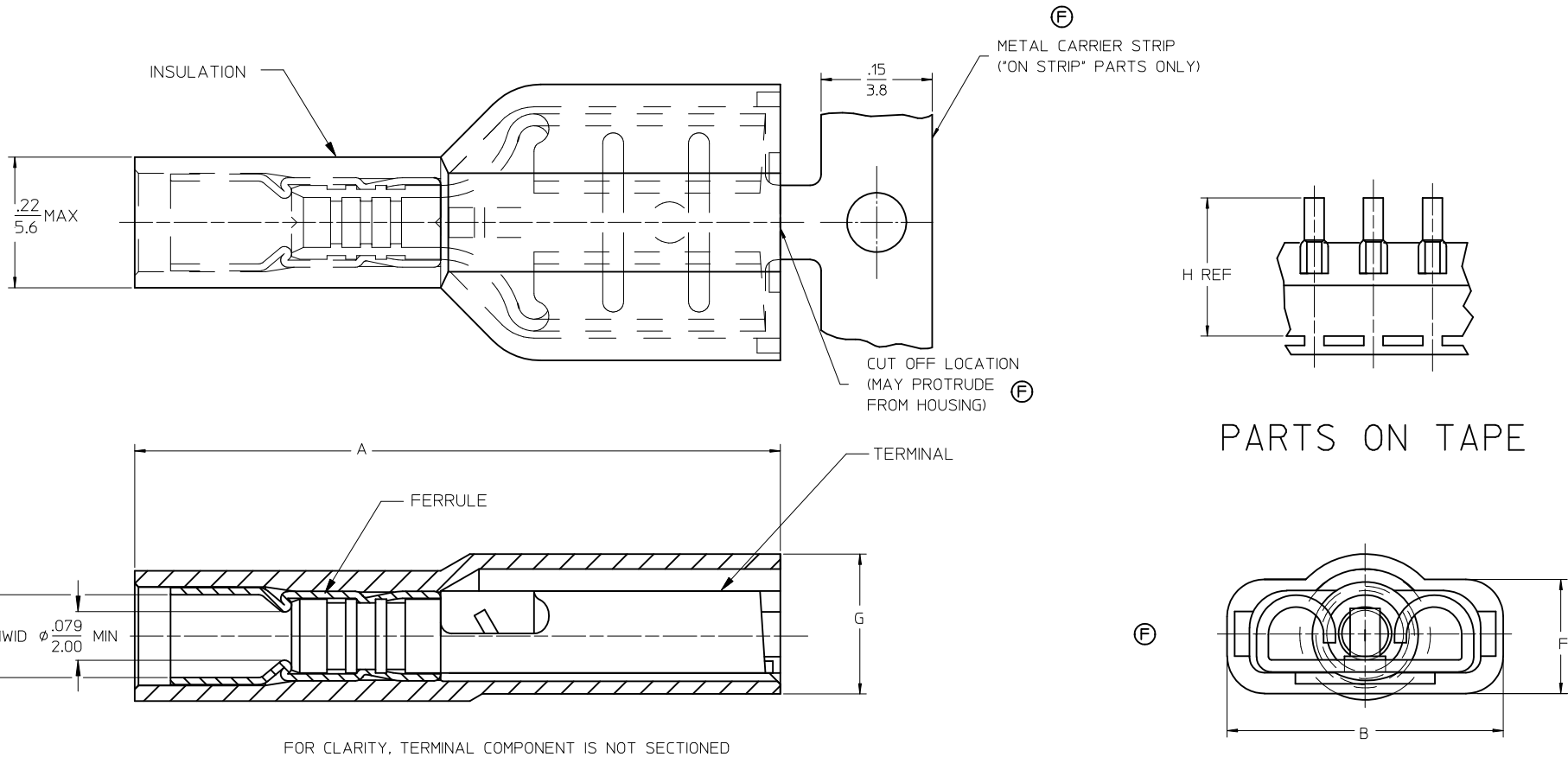

SALES DRAWING

NOTES:

- MATERIAL: TERMINAL BRASS
 TERMINAL PLATING: ELECTRO TIN
 FERRULE: COPPER ALLOY
 FERRULE PLATING: ELECTRO TIN
 INSULATION: NYLON 94V2, COLOR BLUE.
- MWD = MAXIMUM WIRE INSULATION DIAMETER
- ASSEMBLY IS ROHS COMPLIANT.

FERRULE MAT'L DESC'R EC NO: MNA2009-0510 DRW:WETHRODAHL 2010/01/04 CHKD:JMACNEIL 2010/01/05 APPR:JMACNEIL 2010/01/05	QUALITY SYMBOLS ▽=0 ▽=0	GENERAL TOLERANCES (UNLESS SPECIFIED)		DIMENSION STYLE IN/MM	SCALE 1:1	DESIGN UNITS INCH	THIRD ANGLE PROJECTION	
		mm	INCH	DRAWN BY BENDERLE	DATE 2005/04/11	TITLE AVIKRIMP FEMALE FIQD 16-14 AWG		
		4 PLACES ± ---	± ---	CHECKED BY R DEROSS	DATE 2005/04/11	MOLEX INCORPORATED		
		3 PLACES ± ---	± .005	APPROVED BY R DEROSS	DATE 2005/04/11	DOCUMENT NO. SD-19002-004	SHEET NO. 1 OF 1	
2 PLACES ± 0.13	± .01	DRAFT WHERE APPLICABLE MUST REMAIN WITHIN DIMENSIONS		MATERIAL NO. SEE CHART	THIS DRAWING CONTAINS INFORMATION THAT IS PROPRIETARY TO MOLEX INCORPORATED AND SHOULD NOT BE USED WITHOUT WRITTEN PERMISSION			
1 PLACE ± 0.25	± ---			SIZE C				