SHIPBOARD/AC POWER BUS VOLTAGE SUPPRESSOR

APPLICATIONS

- ✓ AC Power Protection
- ✓ Shipboard (Line-Line) Protection
- ✓ Differential AC Power Bus
- ✓ Aircraft AC Power Bus

FEATURES

- ✓ *Meets the Following Military Specifications:*
 - *DOD-STD-1399*
 - *MIL-STD-704A*
- ✓ 60 & 90 kilowatts Peak Pulse Power per Line (tp=1.2/50µs)
- ✓ Each Device 100% Tested
- ✓ 200 Volts Bidirectional

MECHANICAL CHARACTERISTICS

- ✓ Hermetically Sealed Glass to Metal Sub-Assemblies
- ✓ Weight 50 grams (Approximate)
- ✓ Flammability rating UL 94V-0
- ✓ Device Marking: Logo & Part Number
- ✓ Screening Available Upon Request - The 60 & 90KS series can be screened upon request for military requirements in accordance with MIL-PRF-19500 (applicable test). Standard screening is available based on the following options:
 - H1 - Submodule Screening per test plans 05231 & 05232
 - H2 - Submodule & Module Screening per test plan 05233
 - H3 - Submodule & Module Screening, Module Group B & C Lot Testing per test plans 05234 & 05235

60,000 WATTS

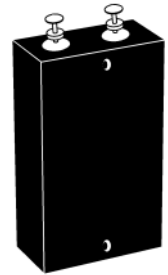

60KS200C

90,000 WATTS

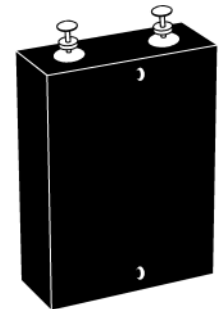

90KS200C

MAXIMUM RATINGS @ 25°C Unless Otherwise Specified

PARAMETER	SYMBOL	VALUE	UNITS
Peak Pulse Power (tp = 1.2/50µs) - See Figure 1	P _{PP}	60 & 90	kilowatts
Operating Temperature	T _J	-55°C to 150°C	°C
Storage Temperature	T _{STG}	-55°C to 150°C	°C
Steady State Power Dissipation @ 50°C	T _A	10.0	Watts

DEVICE CHARACTERISTICS

ELECTRICAL CHARACTERISTICS PER LINE @ 25°C Unless Otherwise Specified					
PART NUMBER	RATED STAND-OFF VOLTAGE	MINIMUM BREAKDOWN VOLTAGE	MAXIMUM CLAMPING VOLTAGE (See Fig. 2)	MAXIMUM LEAKAGE CURRENT	MAXIMUM PEAK PULSE CURRENT (See Fig. 2)
	V_{WM} VOLTS	@ 1mA $V_{(BR)}$ VOLTS	@ I_{PP} V_C VOLTS	@ V_{WM} I_D μA	I_{PPM} AMPS
60KS200C	180	200	335	10	180
90KS200C	180	200	280	0.5	180

**FIGURE 1
PEAK PULSE POWER VS PULSE TIME**

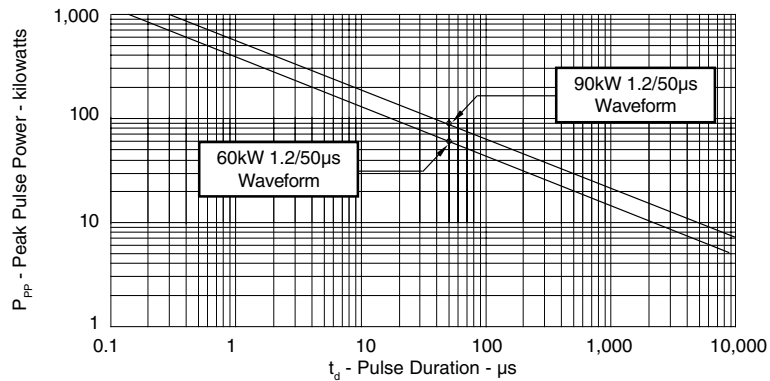

**FIGURE 2
PULSE WAVE FORM**

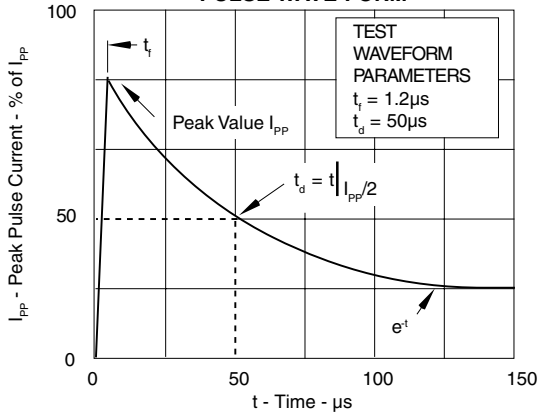

**FIGURE 3
POWER DERATING CURVE**

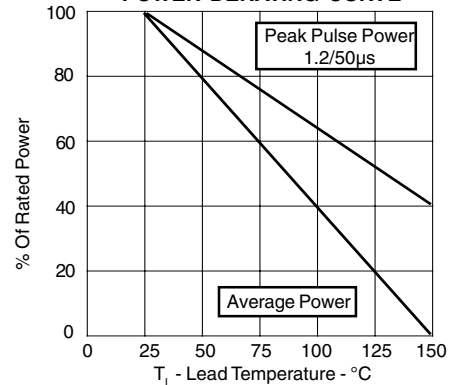

60KS200C & 90KS200C

PACKAGE OUTLINE & DIMENSIONS

60KS200C PACKAGE OUTLINE

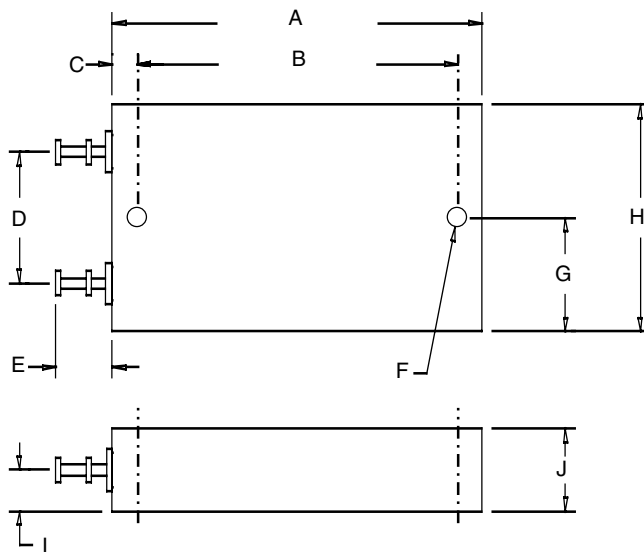

60KS200C

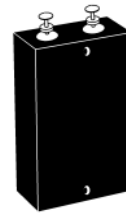

DIMENSIONS

DIM	MILLIMETERS		INCHES	
	MIN	MAX	MIN	MAX
A	56.38	57.91	2.22	2.28
B	49.02	50.03	1.93	1.97
C	3.43	4.17	0.135	0.165
D*	20.32	20.32	0.800	0.800
E	8.26	9.27	0.325	0.365
F*	3.18 DIA	3.18 DIA	0.125 DIA	0.125 DIA
G	16.76	18.29	0.660	0.720
H	34.16	35.69	1.345	1.405
I*	6.35	6.35	0.250	0.250
J	11.94	13.46	0.470	0.530

90KS200C PACKAGE OUTLINE

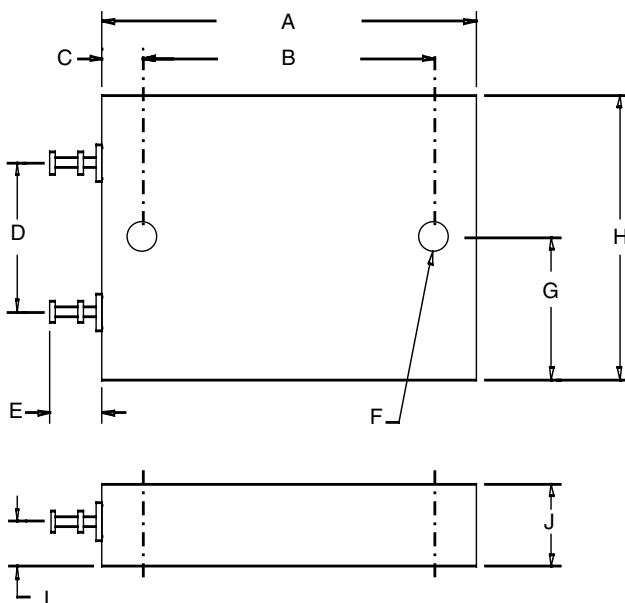

90KS200C

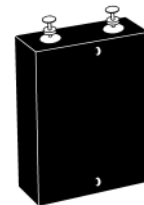

DIMENSIONS

DIM	MILLIMETERS		INCHES	
	MIN	MAX	MIN	MAX
A	-	63.50	-	2.50
B	47.75	48.77	1.880	1.920
C	6.10	6.60	0.240	0.260
D	24.89	25.91	0.980	1.020
E	-	10.16	-	0.400
F	4.90 DIA	5.21 DIA	0.193 DIA	0.205 DIA
G	22.66	23.06	0.892	0.908
H	45.34	46.10	1.785	1.815
I	6.48	7.49	0.255	0.295
J	-	13.97	-	0.550

Outline & Dimensions: Rev 0 - 4/02, 06033

Note*: Dimensions are nominal.

COPYRIGHT © ProTek Devices 2004

SPECIFICATIONS: ProTek reserves the right to change the electrical and or mechanical characteristics described herein without notice (except JEDEC).

DESIGN CHANGES: ProTek reserves the right to discontinue product lines without notice, and that the final judgement concerning selection and specifications is the buyer's and that in furnishing engineering and technical assistance, ProTek assumes no responsibility with respect to the selection or specifications of such products.

ProTek Devices

2929 South Fair Lane, Tempe, AZ 85282

Tel: 602-431-8101 Fax: 602-431-2288

E-Mail: sales@protekdevices.com

Web Site: www.protekdevices.com