

PLEASE CHECK WWW.MOLEX.COM FOR LATEST PART INFORMATION

Part Number: [0190980070](#)
Status: **Active**
Description: Krimptite™ Snap Spade Terminal, for 10-12 AWG Wire, Stud Size 5 (M3), 16.87mm (.664") Length

Documents:

[Drawing \(PDF\)](#) [RoHS Certificate of Compliance \(PDF\)](#)

Agency Certification

CSA LR18689
 UL E32244

General

Product Family Ring and Spade Terminals
 Series [19098](#)
 Crimp Quality Equipment Yes
 Mil-Spec N/A
 Product Name Krimptite™
 Type Spade Snap

Physical

Barrel Type Closed
 Insulation None
 Material - Plating Mating Tin
 Packaging Type Adhesive Tape on Reel
 Stud Size 5 (M3)
 Wire Size AWG 10, 12
 Wire Size mm² 3.30 - 5.00

Material Info

Old Part Number C-1710-06T

Reference - Drawing Numbers

Sales Drawing CCD10502

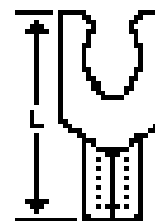

Series
 image - Reference only

EU RoHS

ELV and RoHS Compliant
REACH SVHC Contains SVHC: No
Halogen-Free Status
Not Reviewed

China RoHS



Need more information on product environmental compliance?

Email productcompliance@molex.com
 For a multiple part number RoHS Certificate of Compliance, [click here](#)

Please visit the [Contact Us](#) section for any non-product compliance questions.

Search Parts in this Series

[19098Series](#)

Application Tooling | [FAQ](#)

Tooling specifications and manuals are found by selecting the products below. Crimp Height Specifications are then contained in the Application Tooling Specification document.

Global

| Description | Product # |
|---|----------------------------|
| ATP Perishable Tool Kit, Used in ATP Presses that Process Product on Tape | 0190270088 |
| Mini-Mac™ Applicator | 0638851000 |

NOTES:

① MATERIAL COPPER (STOCK TKN. $\frac{.040}{1.02}$)
 PLATING ELECTRO TIN (.0003 MIN.)

FILE NO. C - CD - 105 - 02

STUD SIZES: ($\pm .005$)

- 02 = .094
- 04 = .119
- 06 = .146
- 08 = .173
- 10 = .198
- 14 = .265
- 56 = .328
- 38 = .390

"UL" LISTING *E32244
 "CSA" LISTING #18689

ALL DIMENSIONS = $\frac{\text{INCHES}}{\text{MM}}$

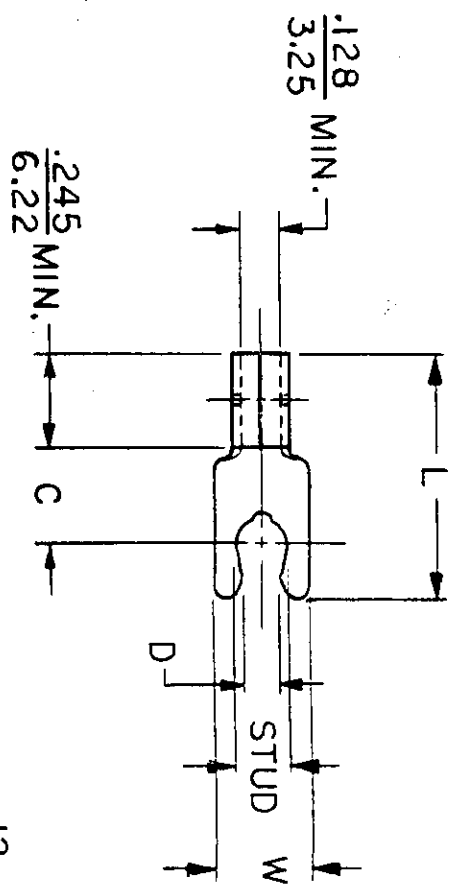

WIRE SIZE: 12-10 AWG
 4.0-6.0 MM²

| PART NUMBER | "W" ±.010 | "C" MIN. | "L" MAX. | "D" ±.005 | AVAILABLE STUD SIZES | DIMENSIONAL TOLERANCES UNLESS OTHERWISE SPECIFIED | | | |
|-------------|----------------------|---------------------|----------------------|---------------------|----------------------------|---|----------|------------|--|
| | | | | | | FRAC. | DEC. | ANG. | NTS |
| C-1710- | $\frac{.250}{6.35}$ | $\frac{.230}{5.84}$ | $\frac{.664}{16.87}$ | $\frac{.105}{2.67}$ | 05 ($\frac{.127}{3.23}$) | DRWN. BY: K | 10-17-84 | SCALE: NTS | TITLE: SNAP SPADE SHORT TONGUE TERMINAL KRIMPTITE 100-SERIES |
| C-1710- | $\frac{.250}{6.35}$ | $\frac{.230}{5.84}$ | $\frac{.664}{16.87}$ | $\frac{.114}{2.90}$ | 06 | CHKD. BY: GZ | 11.2.84 | APPRD. BY: | |
| C-1711- | $\frac{.375}{9.53}$ | $\frac{.261}{6.63}$ | $\frac{.725}{18.43}$ | $\frac{.139}{3.53}$ | 08 | | | | |
| C-1712- | $\frac{.406}{10.31}$ | $\frac{.261}{6.63}$ | $\frac{.773}{19.63}$ | $\frac{.156}{3.96}$ | 10 | | | | |



DWG. NO. A CUSTOMER DWG.