

General Description

The MIC841 and MIC842 are micropower, precision voltage comparator with an on-chip voltage reference.

Both devices are intended for voltage monitoring applications, external resistors are used to set the voltage monitor threshold and when the threshold is crossed the outputs switch polarity.

The MIC842 incorporates a voltage reference and comparator with fixed internal hysteresis; two external resistors are used to set the switching threshold voltage. The MIC841 provides a similar function with user adjustable hysteresis, this part requires three external resistors to set the upper and lower thresholds (the difference between the threshold voltages being the hysteresis voltage).

Both the MIC841 and MIC842 are available with push-pull outputs and active-high or active-low inputs. The active-low part is also available with an open-drain output.

Supply current is extremely low (1.5µA, typical), making it ideal for portable applications.

The MIC841/2 is supplied in Micrel's Teeny™ 5-lead SC-70 package.

Ordering Information

Part Number	Marking	Hysteresis Adjustment	Output Stage	Output Function	Temperature Range	Package
MIC841HBC5	B13	External	Push Pull	Active High	−40°C to +85°C	SC70-5
MIC841LBC5	B14	External	Push Pull	Active Low	−40°C to +85°C	SC70-5
MIC841NBC5	B15	External	Open Drain	Active Low	−40°C to +85°C	SC70-5
MIC842HBC5	B16	Internal	Push Pull	Active High	−40°C to +85°C	SC70-5
MIC842LBC5	B17	Internal	Push Pull	Active Low	−40°C to +85°C	SC70-5
MIC842NBC5	B18	Internal	Open Drain	Active Low	−40°C to +85°C	SC70-5

Typical Application

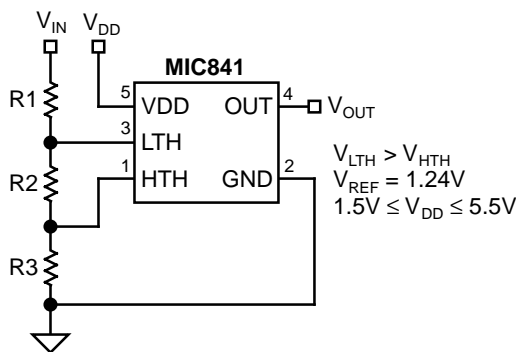

Threshold detection with hysteresis set by a third external resistor

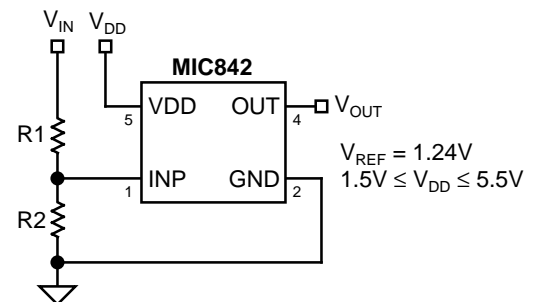

Threshold detector with internal fixed hysteresis

Teeny™ is a trademark of Micrel, Inc.

Micrel, Inc. • 1849 Fortune Drive • San Jose, CA 95131 • USA • tel + 1 (408) 944-0800 • fax + 1 (408) 944-0970 • <http://www.micrel.com>

Pin Configuration

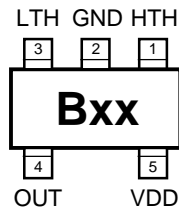

MIC841
SC-70-5 (C5)

Pin Description MIC841

Pin Number	Pin Name	Pin Function
1	HTH	High-Voltage Threshold (Input): Analog input to a comparator. This is the voltage input assigned to detect a high-voltage condition when the level on this pin exceeds V_{REF} , OUT is asserted and the condition is latched until $V_{LTH} < V_{REF}$.
2	GND	Ground
3	LTH	Low-Voltage Threshold (Input): Analog input to a comparator. This is the voltage input assigned to detect a low voltage condition. When the level on this pin falls below V_{REF} , OUT is de-asserted and the condition is latched until $V_{HTH} > V_{REF}$.
4	OUT	Output: Active-high, open-drain output. This output is deasserted and latched when $V_{LTH} < V_{REF}$, indicating a low voltage condition. This state remains latched until $V_{HTH} > V_{REF}$.
5	VDD	Power Supply (Input): Independent supply input for internal circuitry.

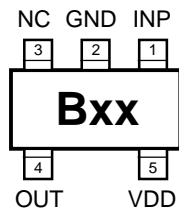

MIC842
SC-70-5 (C5)

Pin Description MIC842

Pin Number	Pin Name	Pin Function
1	INP	Input: Analog input to the comparator. When $V_{INP} > V_{REF} + V_{HYST}$, V_{OUT} is asserted to a logic-high level output.
2	GND	Ground
3	NC	No Connect
4	OUT	Output: Active-high, open-drain output. This output is de-asserted when $V_{INP} < V_{REF}$, indicating a low voltage input. The output is asserted when $V_{INP} > V_{REF} + V_{HYST}$.
5	VDD	Power Supply (Input): Independent supply input for internal circuitry.

Absolute Maximum Ratings (Note 1)

Supply Voltage (V_{DD})	-0.3V to +7V
Input Voltage (V_{INP})	+7V
Output Current (I_{OUT})	20mA
Storage Temperature (T_S)	-65°C to +150°C
ESD Rating, Note 3	1kV

Operating Ratings (Note 2)

Supply Voltage (V_{DD})	+1.5V to +5.5V
Input Voltage (V_{INP})	-0.3V to 6V
Ambient Temperature Range (T_A)	-40°C to +85°C
Junction Temperature (T_J)	Internally Limited
Package Thermal Resistance (θ_{JA})	450°C/W

Electrical Characteristics

1.5V $\leq V_{DD} \leq 5.5V$; $T_A = +25^\circ\text{C}$, **bold** values indicate $-40^\circ\text{C} \leq T_A \leq +85^\circ\text{C}$; unless noted

Symbol	Parameter	Condition	Min	Typ	Max	Units
I_{DD}	Supply Current	output not asserted		1.5	3	μA
I_{INP}	Input Leakage Current			0.005	10	nA
V_{REF}	Reference Voltage	0°C to 85°C	1.225	1.240	1.256	V
		-40°C to 85°C	1.221	1.240	1.259	V
V_{HYST}	Hysteresis Voltage, Note 4	842 only	8	20	35	mV
t_D	Propagation Delay	$V_{INP} = 1.352V$ to $1.128V$		12		μs
		$V_{INP} = 1.143V$ to $1.367V$		8		μs
V_{OUT}	Output Voltage-Low, Note 5	OUT de-asserted, $I_{SINK} = 1.6\text{mA}$, $V_{DD} \geq 1.6V$		0.05	0.3	V
		OUT de-asserted, $I_{SINK} = 100\mu\text{A}$, $V_{DD} \geq 1.2V$,		0.005	0.4	V

Note 1. Exceeding the absolute maximum rating may damage the device.

Note 2. The device is not guaranteed to function outside its operating rating.

Note 3. Devices are ESD sensitive. Handling precautions recommended. Human body model, 1.5k in series with 100pF.

Note 4. $V_{HTH} = V_{REF} + V_{HYST}$.

Note 5. V_{DD} operating range is 1.5V to 5.5V. Output is guaranteed to be held low down to $V_{DD} = 1.2V$.

Block Diagrams

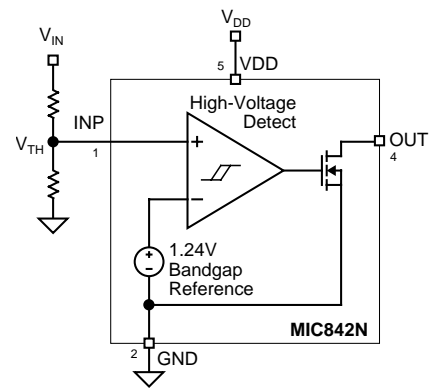
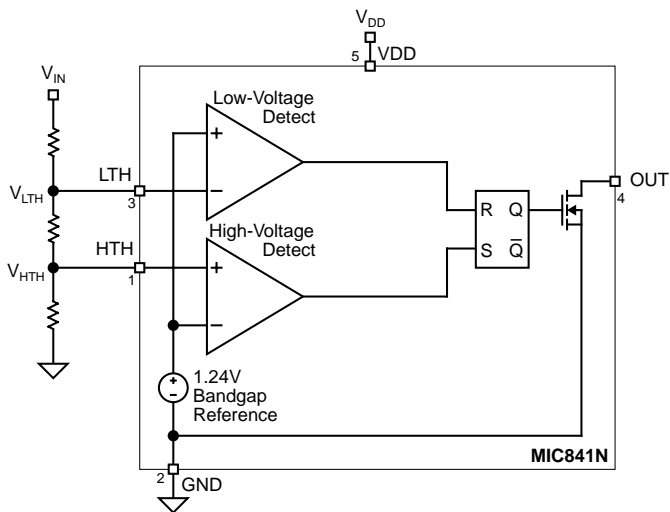
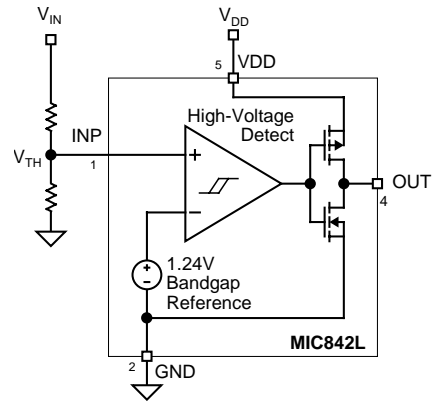
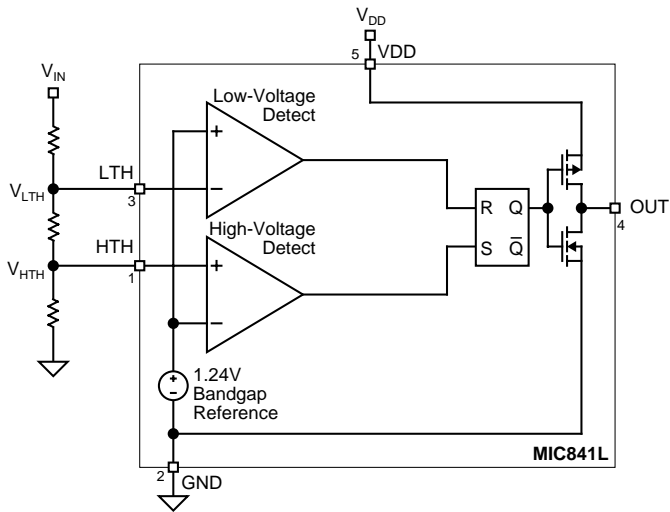
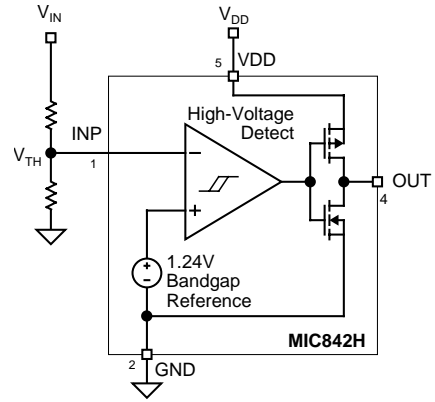
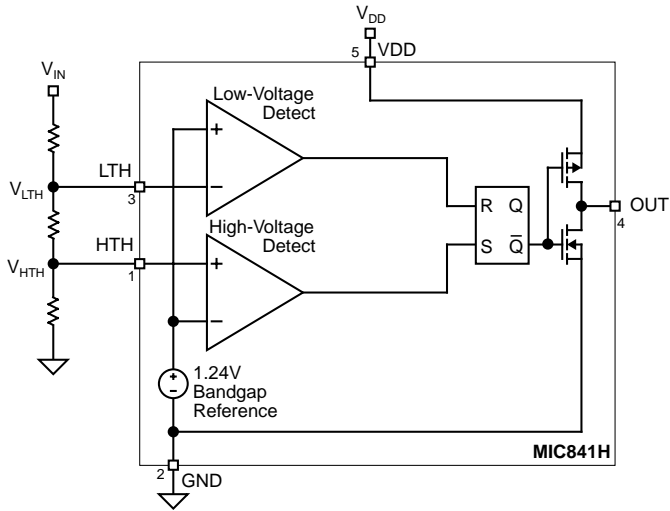

Applications Information

Output

The the MIC841N and MIC842N outputs are an open-drain MOSFET so most applications will require a pull-up resistor. The value of the resistor should not be too large or leakage effects may dominate. 470kΩ is the maximum recommended value. Note that the output may be pulled up as high as 6V regardless of the IC's supply voltage. See "Electrical Characteristics."

When working with large resistors on the input to the devices a small amount of leakage current can cause voltage offsets that degrade system accuracy. The maximum recommended total resistance from V_{IN} to ground is 3MΩ. The accuracy of the resistors can be chosen based upon the accuracy required by the system. The inputs may be subjected to voltages as high as 6V steady-state without adverse effects of any kind regardless of the IC's supply voltage. This applies even if the supply voltage is zero. This permits the situation in which the IC's supply is turned off, but voltage is still present on the inputs. See "Electrical Characteristics."

Programming the MIC841 Thresholds

The low-voltage threshold is calculated using:

$$V_{IN(lo)} = V_{REF} \left(\frac{R1 + R2 + R3}{R2 + R3} \right)$$

The high-voltage threshold is calculated using:

$$V_{IN(hi)} = V_{REF} \left(\frac{R1 + R2 + R3}{R3} \right)$$

where, for both equations:

$$V_{REF} = 1.240V$$

In order to provide the additional criteria needed to solve for the resistor values, the resistors can be selected such that they have a given total value, that is, $R1 + R2 + R3 = R_{TOTAL}$. A value such as 1MΩ for R_{TOTAL} is a reasonable value because it draws minimum current but has no significant effect on accuracy.

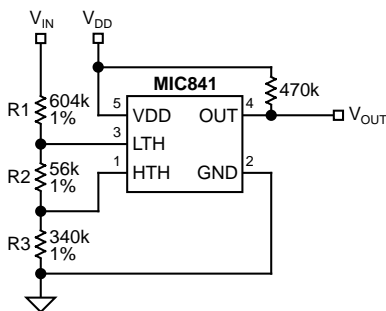

Figure 1. Example Circuit

Once the desired trip points are determined, set the $V_{IN(hi)}$ threshold first.

For example, use a total of $1M\Omega = R1 + R2 + R3$. For a typical single-cell lithium ion battery, 3.6V is a good "high threshold" because at 3.6V the battery is moderately charged. Solving for R3:

$$V_{IN(hi)} = 3.6V = 1.24 \left(\frac{1M\Omega}{R3} \right)$$

$$R3 = 344k\Omega$$

Once R3 is determined, the equation for $V_{IN(lo)}$ can be used to determine R2. A single lithium-ion cell, for example, should not be discharged below 2.5V. Many applications limit the drain to 3.1V. Using 3.1V for the $V_{IN(lo)}$ threshold allows calculation of the two remaining resistor values.

$$V_{IN(lo)} = 3.1V = 1.24 \left(\frac{1M\Omega}{R2 + 344k} \right)$$

$$R2 = 56k\Omega$$

$$1M\Omega - (R2 + R3) = R1$$

$$R1 = 600k\Omega$$

The accuracy of the resistors can be chosen based upon the accuracy required by the system.

The inputs may be subjected to voltages as high as 6V steady state without adverse effects of any kind, regardless of the IC supply voltage. This applies even if the supply voltage is zero. This permits the situation in which the IC supply is turned off, but voltage is still present on the inputs. See "Electrical Characteristics."

Programming the MIC842 Thresholds

The voltage threshold is calculated using:

$$V_{IN(lo)} = V_{REF} \left(\frac{R1 + R2}{R2} \right)$$

where:

$$V_{REF} = 1.240V$$

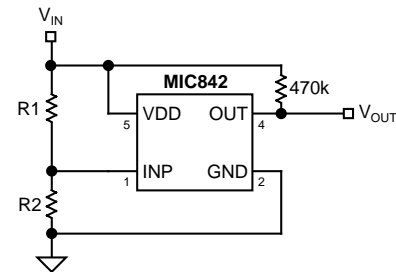

Figure 2. Example Circuit

In order to provide the additional criteria needed to solve for the resistor values, the resistors can be selected such that they have a given total value, that is, $R1 + R2 = R_{TOTAL}$. A value such as 1MΩ for R_{TOTAL} is a reasonable value because it draws minimum current but has no significant effect on accuracy.

Input Transients

The MIC841/2 is inherently immune to very short negative-going "glitches." Very brief transients may exceed the $V_{IN(lo)}$ threshold without tripping the output.

As shown in Figure 3, the narrower the transient, the deeper the threshold overdrive that will be ignored by the MIC841/2. The graph represents the typical allowable transient duration for a given amount of threshold overdrive that will not generate an output.

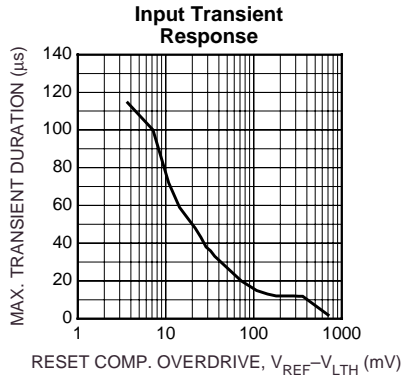
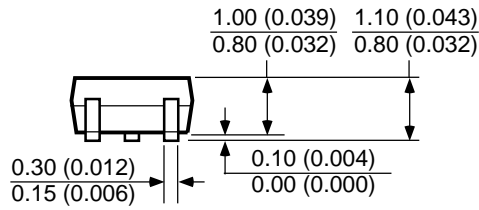
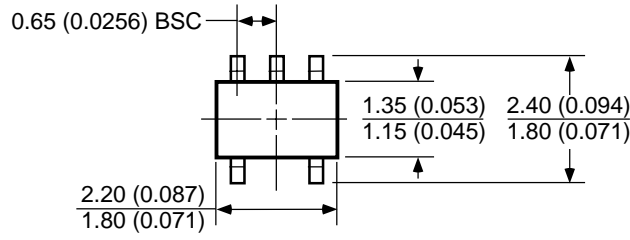
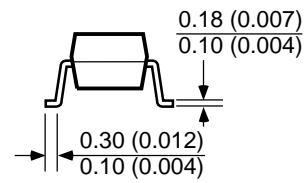

Figure 3. Input Transient Response

Package Information



DIMENSIONS:
MM (INCH)



SC-70 (C5)

MICREL INC. 1849 FORTUNE DRIVE SAN JOSE, CA 95131 USA

TEL + 1 (408) 944-0800 FAX + 1 (408) 944-0970 WEB <http://www.micrel.com>

This information is believed to be accurate and reliable, however no responsibility is assumed by Micrel for its use nor for any infringement of patents or other rights of third parties resulting from its use. No license is granted by implication or otherwise under any patent or patent right of Micrel Inc.

© 2000 Micrel Incorporated