

Specification No. JECXDE-0015

To Mouser Electronics

SPECIFICATION

Date: December 21, 2012

Product Description: Electrical Double Layer Capacitor

Customer Part Number:

Murata Part Number: DMF3R5R5L334M3DTA0

Stamp or signature for receipt		
We received this documents		
/ /		
Company Name _____		
Section Name _____		
Mgr		Eng.

Issue Section
Company Name

Mgr. Atsushi Kawashima

Murata Manufacturing Co., Ltd.

High Performance Power Device Dept. Eng. Atsutaka Mori

Sales Section

Murata Manufacturing Co., Ltd.

Specification of Electrical Double Layer Capacitor

1. Scope

These specifications are applicable for Electrical Double Layer Capacitor (EDLC) for consumer electronic equipments. For other markets and applications please contact your local Murata sales or engineering representative. This specification outlines detailed information for double cell EDLC for peak assist applications. For use under different conditions within the scope of these specifications, please consult a Murata sales or engineering representative.

2. Part Number Description

DMF □□ □□□ □ □□□ □ □□ □ □□

(1) (2) (3) (4) (5) (6) (7) (8) (9)

Number	Name	Code ex.	Specification																		
(1)	Series	DMF	<ul style="list-style-type: none"> > Thin laminate type > Operating temperature: -30deg C~70 deg C As shown below, please use this device within a specified period at each temperature 50 deg C,4.2V: 37,000hrs 60 deg C,4.2V: 15,000hrs 70 deg C,4.2V: 6,600hrs > Storage temperature: -30deg C~85 deg C > Peak voltage 5.5V and constant load 4.2V max 																		
(2)	Dimensions	3R	<table border="1" style="width: 100%; border-collapse: collapse;"> <thead> <tr> <th rowspan="2">Code</th> <th rowspan="2">LW (Package size)</th> <th colspan="3">Thickness (mm)</th> </tr> <tr> <th colspan="2">@ 25DegC</th> <th>@ 70DegC</th> </tr> <tr> <td></td> <td></td> <th>Initial</th> <th>T Max @ End life</th> <th>after 168hr</th> </tr> </thead> <tbody> <tr> <td>3R</td> <td>L:21.0+/-0.5mm W:14.0+/-0.5mm</td> <td>2.5 (typical)</td> <td>2.8Max</td> <td>3.0Max</td> </tr> </tbody> </table> <p>T: Measured by 10mmΦplate with 0.9N. Details shown in section 5.</p>	Code	LW (Package size)	Thickness (mm)			@ 25DegC		@ 70DegC			Initial	T Max @ End life	after 168hr	3R	L:21.0+/-0.5mm W:14.0+/-0.5mm	2.5 (typical)	2.8Max	3.0Max
Code	LW (Package size)	Thickness (mm)																			
		@ 25DegC		@ 70DegC																	
		Initial	T Max @ End life	after 168hr																	
3R	L:21.0+/-0.5mm W:14.0+/-0.5mm	2.5 (typical)	2.8Max	3.0Max																	
(3)	Rated voltage	5R5	5.50V: Peak loading voltage. 4.20V: Continuous loading voltage *Definition of rated voltage 5.50V for 500hrs at 40degC.(ESR:120% of Initial, Cap: 80% of Initial) 4.20V for 8000hrs at 40degC.(ESR:140% of initial,Cap:70% of Initial) (est) * Reference *4.20V for 1000hrs at 70degC(Reference) *4.00V for 32000hrs at 40degC(est)																		
(4)	ESR	L	<table border="1" style="width: 100%; border-collapse: collapse;"> <thead> <tr> <th>Code</th> <th>Initial ESR @ 1kHz (m Ohm) @25degC</th> </tr> </thead> <tbody> <tr> <td>L</td> <td>60 +/- 10mohm</td> </tr> </tbody> </table>	Code	Initial ESR @ 1kHz (m Ohm) @25degC	L	60 +/- 10mohm														
Code	Initial ESR @ 1kHz (m Ohm) @25degC																				
L	60 +/- 10mohm																				
(5)	Nominal Capacitance	334	<table border="1" style="width: 100%; border-collapse: collapse;"> <thead> <tr> <th>Code</th> <th>Capacitance</th> </tr> </thead> <tbody> <tr> <td>334</td> <td>330mF(33x10⁴ uF)</td> </tr> </tbody> </table>	Code	Capacitance	334	330mF(33x10 ⁴ uF)														
Code	Capacitance																				
334	330mF(33x10 ⁴ uF)																				
(6)	Cap Tolerance	M	M: +/-20%(Standard) , K: +/-10%																		
(7)	Terminal type	3D	Au plating: 3D Terminal pattern: Refer to mechanical drawing shown in section 5.																		
(8)	Packaging	T	T: Tray package Details shown in section 7.																		
(9)	In-house specification	A0	Murata management code																		

Specification of Electrical Double Layer Capacitor

3. DMF series

Part Number (for Sample)	Rated Voltage		ESR @1kHz @25degC	Nominal Capacitance @25degC	Dimensions(mm)			Leakage current Max @96hr
	Peak (V)	Constant(V)			L	W	T	
DMF3R5R5L334M3DTA0	5.5	4.2	60 +/-10.0 mohm	330mF +/-20%	21.0 +/-0.5	14.0 +/-0.5	2.5	10uA

T: Measured by 10mmΦplate with 0.9N.

As for the temperature characteristics of ESR and capacitance, please refer to "8-8. Temperature characteristics".

4. Product Structure

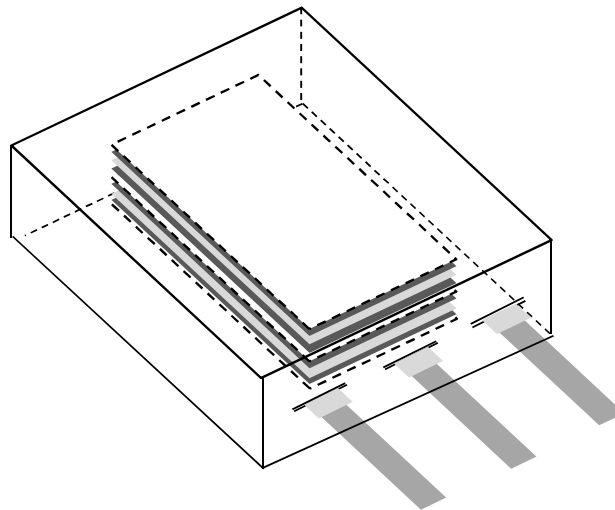

4-1. Electrolyte : Inside of 4-4-1.Laminate

4-2. Electrode : Consisting of 4-2-1. Al Foil and 4-2-2. Carbon

4-3. Separator :

4-2-1. Al Foil :

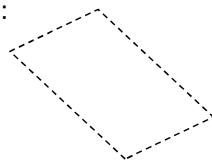

4-2-2. Carbon :

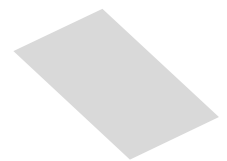
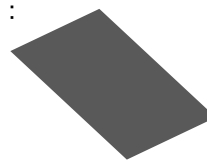

4-4. Outer Package: Consisting of 4-4-1. Laminate, 4-4-2. Withdraw Terminal + Outer Terminal,

4-4-1. Laminate :

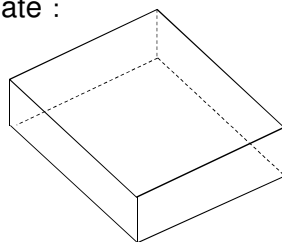

4-4-2. Withdraw Terminal + Outer Terminal :

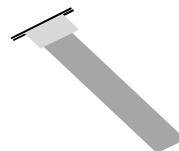

Specification of Electrical Double Layer Capacitor

5. Mechanical Drawing

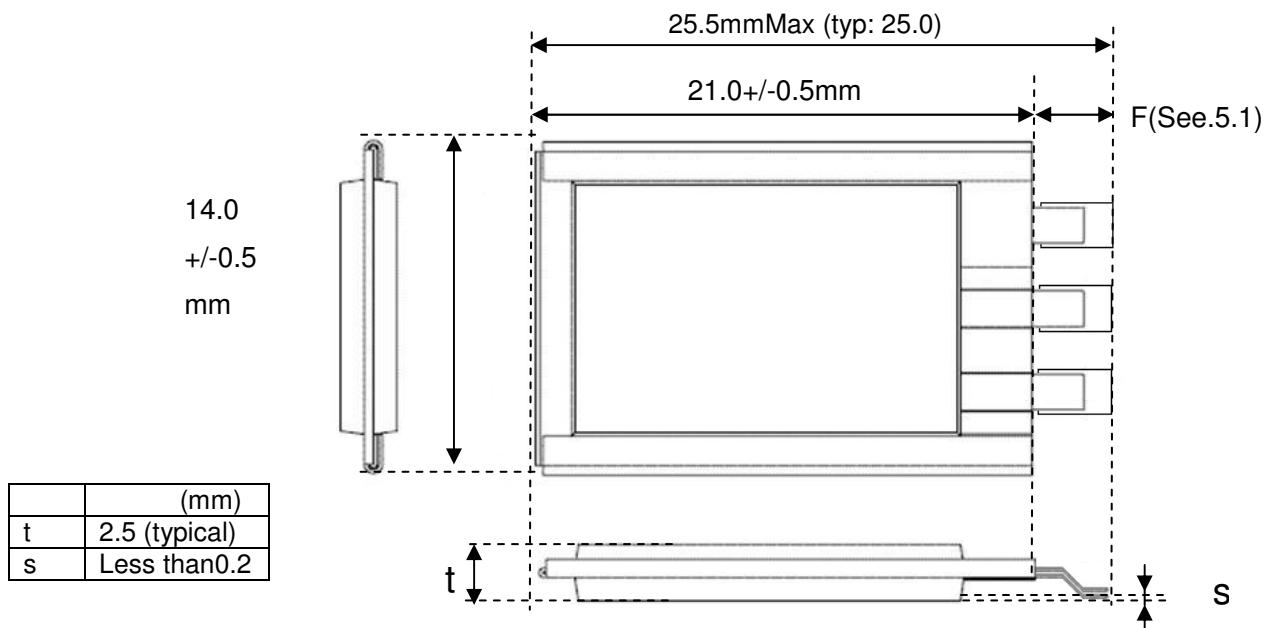

*: Measured by 10mmΦplate with 0.9N

5.1 Electrode size

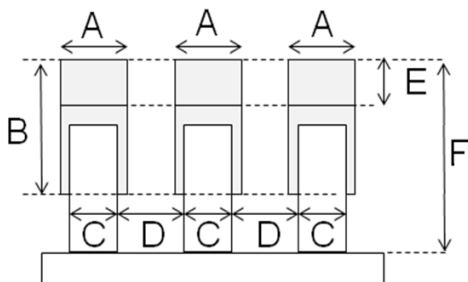

- A=1.7+/-0.2mm
- B=2.6+/-0.2mm
- C=1.5mm (typ)
- D=2.0mm (typ)
- E=1.1mm (typ)
- F=4.8mmMax (typ: 4.3mm)
- E: Length of soldering area

6. Marking

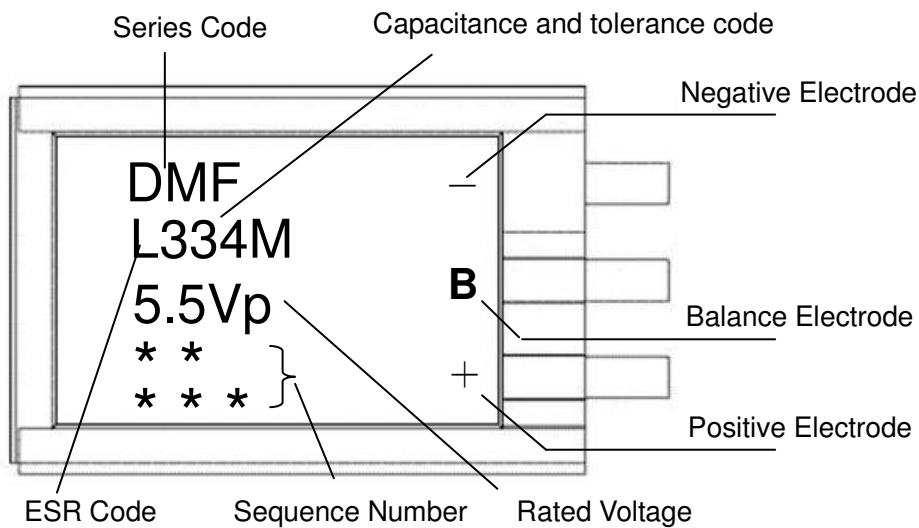

7. Packaging

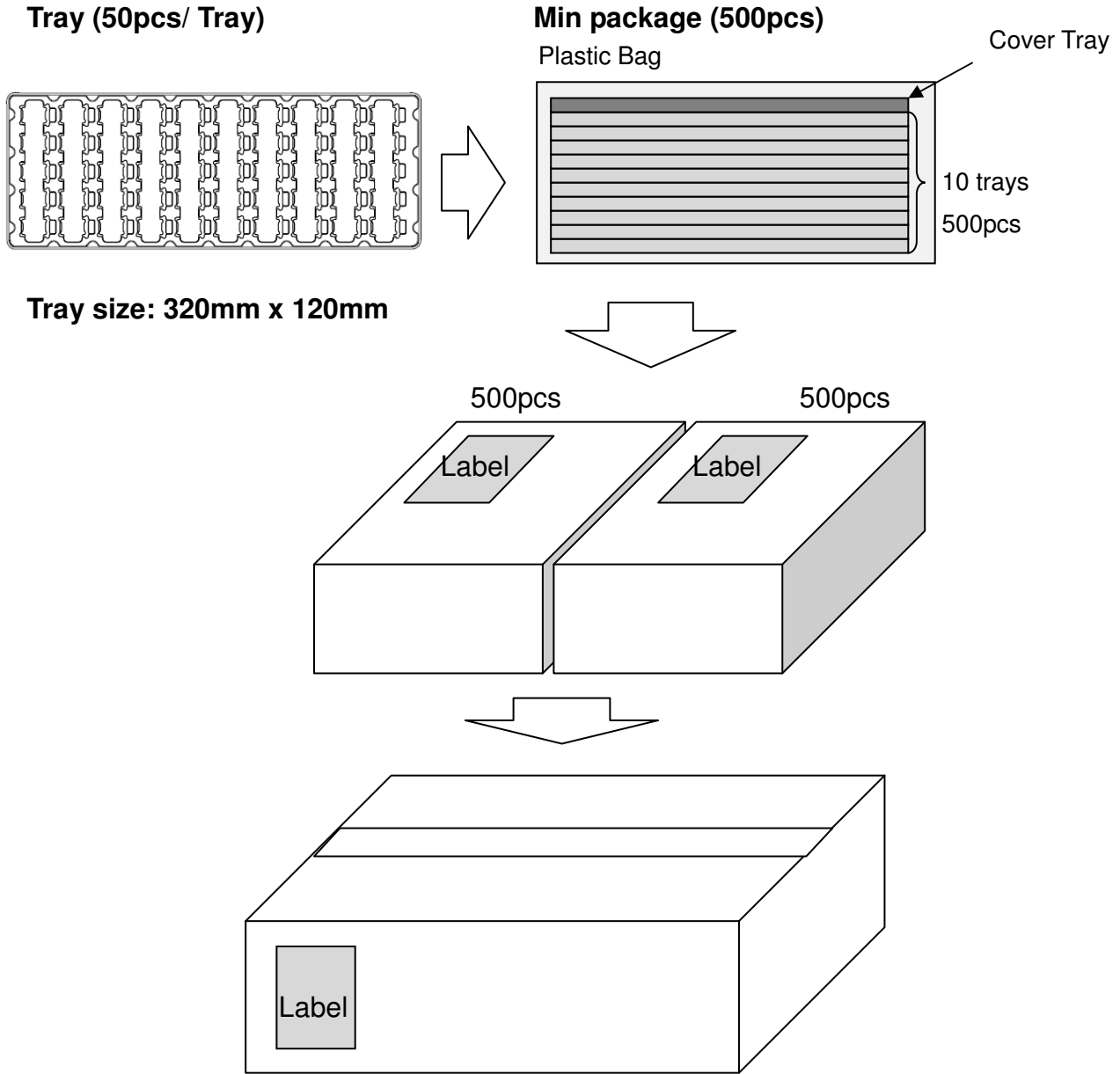



Tray size: 320mm x 120mm

***Minimum Shipping Quantity: 500pcs**

8. Performance

No	Item	Specification	Validation Method				
1	Operating Temperature	-30degC ~ +70degC					
2	Storage Temperature	-30degC ~ +85degC for 168hrs					
3	Appearance	No external abnormality	Visual				
4	Dimensions	Refer to section 5	Microscope, Vernier Caliper				
5	Nominal Capacitance	<table border="1"> <thead> <tr> <th>Code</th> <th>Capacitance</th> </tr> </thead> <tbody> <tr> <td>334</td> <td>330mF +/-20%</td> </tr> </tbody> </table>	Code	Capacitance	334	330mF +/-20%	<p>Discharge method 1. Charge capacitor for 30min at rated peak voltage 5.5V. 2. Then discharge</p> <p>V1: 80% of rated peak voltage V2: 40% of rated peak voltage T1: Time with voltage V1 T2: Time with voltage V2 Discharge current: 100mA</p> $C = \frac{I \times (T_2 - T_1)}{V_1 - V_2}$
Code	Capacitance						
334	330mF +/-20%						
6	ESR	<table border="1"> <thead> <tr> <th>Code</th> <th>Initial ESR @ 1kHz (m Ohm) @25C</th> </tr> </thead> <tbody> <tr> <td>L</td> <td>60 +/- 10mohm</td> </tr> </tbody> </table>	Code	Initial ESR @ 1kHz (m Ohm) @25C	L	60 +/- 10mohm	<p><Impedance Method> Measured at AC1kHz. Current: 10mA - 200mA</p>
Code	Initial ESR @ 1kHz (m Ohm) @25C						
L	60 +/- 10mohm						
7	Leakage current	Less than or equal to 10uA at 96hrs.	Temperature: 25+/-2degC				

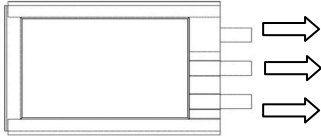
Specification of Electrical Double Layer Capacitor

No	Item	Specification	Validation Method														
8	Temperature characteristics	Capacitance <table border="1"> <thead> <tr> <th>Temperature (deg C)</th> <th>Capacitance change versus 25degC</th> </tr> </thead> <tbody> <tr> <td>70 (Max temp.)</td> <td>+/-10%</td> </tr> <tr> <td>40(Ref.)</td> <td>+/-10%</td> </tr> <tr> <td>25</td> <td>-</td> </tr> <tr> <td>0(Ref.)</td> <td>+/-10%</td> </tr> <tr> <td>-20(Ref.)</td> <td>+/-10%</td> </tr> <tr> <td>-30 (Min temp.)</td> <td>+/-10%</td> </tr> </tbody> </table>	Temperature (deg C)	Capacitance change versus 25degC	70 (Max temp.)	+/-10%	40(Ref.)	+/-10%	25	-	0(Ref.)	+/-10%	-20(Ref.)	+/-10%	-30 (Min temp.)	+/-10%	Temperature setting value +/- 2degC. > Capacitance measured with discharge method specified in No 5. > ESR measured with AC 1kHz specified in No 6.
		Temperature (deg C)	Capacitance change versus 25degC														
70 (Max temp.)	+/-10%																
40(Ref.)	+/-10%																
25	-																
0(Ref.)	+/-10%																
-20(Ref.)	+/-10%																
-30 (Min temp.)	+/-10%																
ESR(@1kHz) <table border="1"> <thead> <tr> <th>Temperature (deg C)</th> <th>ESR change relative to initial value(@ 1kHz)</th> </tr> </thead> <tbody> <tr> <td>70(Max temp.)</td> <td>+/-30%</td> </tr> <tr> <td>40(Ref)</td> <td>+/-15%</td> </tr> <tr> <td>25</td> <td>-</td> </tr> <tr> <td>0(Ref)</td> <td>+40% or less</td> </tr> <tr> <td>-20(Ref)</td> <td>+80% or less</td> </tr> <tr> <td>-30(Min temp.)</td> <td>+100% or less</td> </tr> </tbody> </table>	Temperature (deg C)	ESR change relative to initial value(@ 1kHz)	70(Max temp.)	+/-30%	40(Ref)	+/-15%	25	-	0(Ref)	+40% or less	-20(Ref)	+80% or less	-30(Min temp.)	+100% or less			
Temperature (deg C)	ESR change relative to initial value(@ 1kHz)																
70(Max temp.)	+/-30%																
40(Ref)	+/-15%																
25	-																
0(Ref)	+40% or less																
-20(Ref)	+80% or less																
-30(Min temp.)	+100% or less																
9-1	Terminal strength 1	No break or crack on any terminal by applying less than 5N.	 Hold the capacitor body and pull terminal.														
9-2	Terminal strength 2	No break or crack on any terminal by applying less than 1N.	 Hold the capacitor body and pull terminal.														
10	Solder wettability	Min 75% of terminal electrode should be covered by new solder.	Preprocessing condition: PCT105degC/Relative humidity 100%/1.22x10 ⁵ Pa for 4 hours Immersion depth (flux and solder): Up to 0.8~1.2mm from terminal root. Solder temperature: 245+/-3degC. Sn-3Ag-0.5Cu Solder immersion time: 2~3 sec Duration: 25+/-2.5mm/s														
11	Solder heat resistance	<table border="1"> <thead> <tr> <th>Item</th> <th>Specification</th> </tr> </thead> <tbody> <tr> <td>Capacitance</td> <td>Satisfy initial value</td> </tr> <tr> <td>ESR</td> <td>Satisfy initial value</td> </tr> <tr> <td>Leakage current</td> <td>Satisfy initial value</td> </tr> <tr> <td>Thickness @25degC</td> <td>Satisfy initial value</td> </tr> <tr> <td>Appearance</td> <td>No abnormality and No electrolyte leakage.</td> </tr> </tbody> </table>	Item	Specification	Capacitance	Satisfy initial value	ESR	Satisfy initial value	Leakage current	Satisfy initial value	Thickness @25degC	Satisfy initial value	Appearance	No abnormality and No electrolyte leakage.	Soldering iron: Wattage 70W (typical) Diameter of soldering tip: 0.8mm Exposed length: 3mm, Solder type: Resin flux cored solder wire (nominal length 1.2mm) Solder: Lead-free solder: Sn-3Ag-0.5Cu Test condition: Soldering tip temperature: 350+/-10degC Heating duration: 3.0+1/-0 sec Test method: *Position the soldering iron pararell to the test spot of terminal *Avoid contact of soldering tip with capacitor body.		
		Item	Specification														
		Capacitance	Satisfy initial value														
		ESR	Satisfy initial value														
		Leakage current	Satisfy initial value														
		Thickness @25degC	Satisfy initial value														
Appearance	No abnormality and No electrolyte leakage.																

Specification of Electrical Double Layer Capacitor

No	Item	Specification	Validation Method																						
12	Vibration tests	<table border="1"> <thead> <tr> <th>Items</th> <th>Specification</th> </tr> </thead> <tbody> <tr> <td>Capacitance</td> <td>Satisfy initial value</td> </tr> <tr> <td>ESR</td> <td>Satisfy initial value</td> </tr> <tr> <td>Leakage current</td> <td>Satisfy initial value</td> </tr> <tr> <td>Thickness @25degC</td> <td>Satisfy initial value</td> </tr> <tr> <td>Appearance</td> <td>No external abnormality and No electrolyte leakage.</td> </tr> </tbody> </table>	Items	Specification	Capacitance	Satisfy initial value	ESR	Satisfy initial value	Leakage current	Satisfy initial value	Thickness @25degC	Satisfy initial value	Appearance	No external abnormality and No electrolyte leakage.	<p>Vibrate the capacitor in the following conditions; Standard charge condition, Fix the capacitor on substrate by double-stick tape and No stress on the terminals Acceleration amplitude: 10~60Hz 2.1G, ~80Hz 1.4G, ~100Hz 0.7G, ~125Hz 0.4G Sweep time: LOG 5 minutes for each way Direction and Duration: 2 hours for each of X and Y(planar) directions, 4 hours for Z(thickness) direction.</p>										
Items	Specification																								
Capacitance	Satisfy initial value																								
ESR	Satisfy initial value																								
Leakage current	Satisfy initial value																								
Thickness @25degC	Satisfy initial value																								
Appearance	No external abnormality and No electrolyte leakage.																								
13	Temperature cycle.	<table border="1"> <thead> <tr> <th>Items</th> <th>Specification</th> </tr> </thead> <tbody> <tr> <td>Capacitance</td> <td>-20% of initial value</td> </tr> <tr> <td>ESR</td> <td>+20% of initial value</td> </tr> <tr> <td>Leakage current</td> <td>Satisfy initial value</td> </tr> <tr> <td>Appearance</td> <td>No abnormality and No electrolyte leakage.</td> </tr> </tbody> </table>	Items	Specification	Capacitance	-20% of initial value	ESR	+20% of initial value	Leakage current	Satisfy initial value	Appearance	No abnormality and No electrolyte leakage.	<p>Temperature Range: -30degC to +85degC 30 minutes each(temperature change should be done within five minutes) Test Cycles: 256 cycles</p> <p>Temperature Cycle</p> <table border="1"> <thead> <tr> <th></th> <th>Temperature</th> </tr> </thead> <tbody> <tr> <td>1</td> <td>Room Temperature 25+/-2degC</td> </tr> <tr> <td>2</td> <td>-30 +/-2degC</td> </tr> <tr> <td>3</td> <td>Room Temperature 25+/-2degC</td> </tr> <tr> <td>4</td> <td>85+/-2degC</td> </tr> <tr> <td>5</td> <td>Room Temperature 25+/-2degC</td> </tr> </tbody> </table> <p>*Test should be done without charging. *Characteristics are measured at 25degC. *Keep device for 2hrs or more at 25degC before measuring.</p>		Temperature	1	Room Temperature 25+/-2degC	2	-30 +/-2degC	3	Room Temperature 25+/-2degC	4	85+/-2degC	5	Room Temperature 25+/-2degC
Items	Specification																								
Capacitance	-20% of initial value																								
ESR	+20% of initial value																								
Leakage current	Satisfy initial value																								
Appearance	No abnormality and No electrolyte leakage.																								
	Temperature																								
1	Room Temperature 25+/-2degC																								
2	-30 +/-2degC																								
3	Room Temperature 25+/-2degC																								
4	85+/-2degC																								
5	Room Temperature 25+/-2degC																								
14	Storage at high temperature.	<table border="1"> <thead> <tr> <th>Items</th> <th>Specification</th> </tr> </thead> <tbody> <tr> <td>Capacitance</td> <td>-20% of initial value</td> </tr> <tr> <td>ESR</td> <td>+20% of initial value</td> </tr> <tr> <td>Leakage current</td> <td>Satisfy initial value</td> </tr> <tr> <td>Thickness @25degC</td> <td>0.1mm thicker than initial thickness</td> </tr> <tr> <td>Thickness @85degC</td> <td>0.3mm thicker than initial thickness</td> </tr> <tr> <td>Appearance</td> <td>No abnormality and No electrolyte leakage.</td> </tr> </tbody> </table>	Items	Specification	Capacitance	-20% of initial value	ESR	+20% of initial value	Leakage current	Satisfy initial value	Thickness @25degC	0.1mm thicker than initial thickness	Thickness @85degC	0.3mm thicker than initial thickness	Appearance	No abnormality and No electrolyte leakage.	<p>Temperature:85+0/-3degC Duration: 168hrs+3/-0hrs *Without charging *Characteristics are measured at 25degC. *Keep device for 2hrs or more at 25degC before measuring.</p>								
Items	Specification																								
Capacitance	-20% of initial value																								
ESR	+20% of initial value																								
Leakage current	Satisfy initial value																								
Thickness @25degC	0.1mm thicker than initial thickness																								
Thickness @85degC	0.3mm thicker than initial thickness																								
Appearance	No abnormality and No electrolyte leakage.																								
15	Storage at high humidity.	<table border="1"> <thead> <tr> <th>Items</th> <th>Specification</th> </tr> </thead> <tbody> <tr> <td>Capacitance</td> <td>-20% of initial value</td> </tr> <tr> <td>ESR</td> <td>+20% of initial value</td> </tr> <tr> <td>Leakage current</td> <td>Satisfy initial value</td> </tr> <tr> <td>Thickness @25degC</td> <td>0.1mm thicker than initial thickness</td> </tr> <tr> <td>Appearance</td> <td>No abnormality and No electrolyte leakage.</td> </tr> </tbody> </table>	Items	Specification	Capacitance	-20% of initial value	ESR	+20% of initial value	Leakage current	Satisfy initial value	Thickness @25degC	0.1mm thicker than initial thickness	Appearance	No abnormality and No electrolyte leakage.	<p>Temperature: 40+0/-3degC Humidity: 90-95% Duration: 240+12/-0 hrs. *Without charging *Characteristics are measured at 25degC. * Keep device for 2hrs or more at 25degC before measuring.</p>										
Items	Specification																								
Capacitance	-20% of initial value																								
ESR	+20% of initial value																								
Leakage current	Satisfy initial value																								
Thickness @25degC	0.1mm thicker than initial thickness																								
Appearance	No abnormality and No electrolyte leakage.																								

Specification of Electrical Double Layer Capacitor

No	Item	Specification	Validation Method												
16	Storage at cold temperatures	<table border="1"> <thead> <tr> <th>Items</th> <th>Specification</th> </tr> </thead> <tbody> <tr> <td>Capacitance</td> <td>Satisfy initial value</td> </tr> <tr> <td>ESR</td> <td>Satisfy initial value</td> </tr> <tr> <td>Leakage current</td> <td>Satisfy initial value</td> </tr> <tr> <td>Thickness @25degC</td> <td>Satisfy initial value</td> </tr> <tr> <td>Appearance</td> <td>No abnormality and No electrolyte leakage.</td> </tr> </tbody> </table>	Items	Specification	Capacitance	Satisfy initial value	ESR	Satisfy initial value	Leakage current	Satisfy initial value	Thickness @25degC	Satisfy initial value	Appearance	No abnormality and No electrolyte leakage.	Temperature: -30+3/-0degC Duration : 168+3/-0hrs *Without charging *Characteristics are measured at 25degC. * Keep device for 2hrs or more at 25degC before measuring.
Items	Specification														
Capacitance	Satisfy initial value														
ESR	Satisfy initial value														
Leakage current	Satisfy initial value														
Thickness @25degC	Satisfy initial value														
Appearance	No abnormality and No electrolyte leakage.														
17-1	High temperature loading -1 (for peak loading)	<table border="1"> <thead> <tr> <th>Items</th> <th>Specification</th> </tr> </thead> <tbody> <tr> <td>Capacitance</td> <td>-20% of initial value</td> </tr> <tr> <td>ESR</td> <td>+20% of initial value</td> </tr> <tr> <td>Leakage current</td> <td>Satisfy initial value</td> </tr> <tr> <td>Thickness @25degC</td> <td>0.1mm thicker than initial thickness.</td> </tr> <tr> <td>Appearance</td> <td>No abnormality and No electrolyte leakage.</td> </tr> </tbody> </table>	Items	Specification	Capacitance	-20% of initial value	ESR	+20% of initial value	Leakage current	Satisfy initial value	Thickness @25degC	0.1mm thicker than initial thickness.	Appearance	No abnormality and No electrolyte leakage.	Voltage: DC 5.5+0/-0.1V Temperature :40+/-2degC Duration: 500+24 /-0hrs Charge and discharge current: 500mA max *Characteristics are measured at 25degC. *Keep device for 2hrs or more at 25degC before measuring.
Items	Specification														
Capacitance	-20% of initial value														
ESR	+20% of initial value														
Leakage current	Satisfy initial value														
Thickness @25degC	0.1mm thicker than initial thickness.														
Appearance	No abnormality and No electrolyte leakage.														
17-2	High temperature loading – 2 (for continuous loading)	<table border="1"> <thead> <tr> <th>Items</th> <th>Specification</th> </tr> </thead> <tbody> <tr> <td>Capacitance</td> <td>-30% of initial value</td> </tr> <tr> <td>ESR</td> <td>+40% of initial value</td> </tr> <tr> <td>Leakage current</td> <td>Satisfy initial value</td> </tr> <tr> <td>Thickness @25degC</td> <td>3.0mm or less</td> </tr> <tr> <td>Appearance</td> <td>No abnormality and No electrolyte leakage.</td> </tr> </tbody> </table>	Items	Specification	Capacitance	-30% of initial value	ESR	+40% of initial value	Leakage current	Satisfy initial value	Thickness @25degC	3.0mm or less	Appearance	No abnormality and No electrolyte leakage.	Voltage: DC 4.2 +0/-0.1 V Temperature: 70+/-2degC Duration: 1000+24/-0hrs Charge and discharge current: 500mA max *Characteristics are measured at 25degC. *Keep device for 2hrs or more at 25degC before measuring.
Items	Specification														
Capacitance	-30% of initial value														
ESR	+40% of initial value														
Leakage current	Satisfy initial value														
Thickness @25degC	3.0mm or less														
Appearance	No abnormality and No electrolyte leakage.														

Specification of Electrical Double Layer Capacitor

No	Item	Specification	Validation Method												
18	Charge-Discharge Cycle Test	<table border="1"> <thead> <tr> <th>Items</th> <th>Specification</th> </tr> </thead> <tbody> <tr> <td>Capacitance</td> <td>-50% of initial value</td> </tr> <tr> <td>ESR</td> <td>+100% of initial value</td> </tr> <tr> <td>Leakage current</td> <td>Satisfy initial value</td> </tr> <tr> <td>Thickness @25degC</td> <td>0.1mm thicker than initial thickness.</td> </tr> <tr> <td>Appearance</td> <td>No abnormality and No electrolyte leakage.</td> </tr> </tbody> </table>	Items	Specification	Capacitance	-50% of initial value	ESR	+100% of initial value	Leakage current	Satisfy initial value	Thickness @25degC	0.1mm thicker than initial thickness.	Appearance	No abnormality and No electrolyte leakage.	<p>Charge voltage: 5.5 +0/-0.1V Temp.: 25 +/-2 degC Current: 5.0+0/-0.1A Cycle number: 50000</p> <p>Profile</p>
Items	Specification														
Capacitance	-50% of initial value														
ESR	+100% of initial value														
Leakage current	Satisfy initial value														
Thickness @25degC	0.1mm thicker than initial thickness.														
Appearance	No abnormality and No electrolyte leakage.														
19-1	High temperature Charge-Discharge Cycle Test 1	<table border="1"> <thead> <tr> <th>Items</th> <th>Specification</th> </tr> </thead> <tbody> <tr> <td>Capacitance</td> <td>-20% of initial value</td> </tr> <tr> <td>ESR</td> <td>+20% of initial value</td> </tr> <tr> <td>Leakage current</td> <td>Satisfy initial value</td> </tr> <tr> <td>Thickness @25degC</td> <td>0.1mm thicker than initial thickness.</td> </tr> <tr> <td>Appearance</td> <td>No abnormality and No electrolyte leakage.</td> </tr> </tbody> </table>	Items	Specification	Capacitance	-20% of initial value	ESR	+20% of initial value	Leakage current	Satisfy initial value	Thickness @25degC	0.1mm thicker than initial thickness.	Appearance	No abnormality and No electrolyte leakage.	<p>Charge voltage: 5.5 +0/-0.1V Temp.: 40 +/-2 degC Charge 3.2V to 5.5V with 500mA Discharge: 5.5V to 3.2V with 500mA Cycle number: 10000</p> <p>Profile</p>
Items	Specification														
Capacitance	-20% of initial value														
ESR	+20% of initial value														
Leakage current	Satisfy initial value														
Thickness @25degC	0.1mm thicker than initial thickness.														
Appearance	No abnormality and No electrolyte leakage.														
19-2	High temperature Charge-Discharge Cycle Test 2	<table border="1"> <thead> <tr> <th>Items</th> <th>Specification</th> </tr> </thead> <tbody> <tr> <td>Capacitance</td> <td>-30% of initial value</td> </tr> <tr> <td>ESR</td> <td>+70% of initial value</td> </tr> <tr> <td>Leakage current</td> <td>Satisfy initial value</td> </tr> <tr> <td>Thickness @25degC</td> <td>3.0mm or less</td> </tr> <tr> <td>Appearance</td> <td>No abnormality and No electrolyte leakage.</td> </tr> </tbody> </table>	Items	Specification	Capacitance	-30% of initial value	ESR	+70% of initial value	Leakage current	Satisfy initial value	Thickness @25degC	3.0mm or less	Appearance	No abnormality and No electrolyte leakage.	<p>Charge voltage: 5.5 +0/-0.1V Temperature: 70 +/-2 degC. Charge Current: 500 +/-10mA Discharge Time: 67msec Charge: 1sec Discharge Current: 5.0+0/-0.1A Cycle number: 10000</p> <p>Profile</p>
Items	Specification														
Capacitance	-30% of initial value														
ESR	+70% of initial value														
Leakage current	Satisfy initial value														
Thickness @25degC	3.0mm or less														
Appearance	No abnormality and No electrolyte leakage.														

Specification of Electrical Double Layer Capacitor

9. Safety Test Specification

No	Item	Specification	Validation Method
1	Puncture	No smoke, ignition or rupture	Preprocessing: Charge up to rated peak voltage at 25degC. Fully penetrate the center of capacitor by a 2.5φ needle. Temperature: 60degC
2	Compression	No smoke, ignition or rupture	Preprocessing: 1. Charge device to rated peak voltage at 25degC. 2. Press the center of the capacitor with 10φ round bar and bend it at 90 degrees.(X and Y directions, Both sides) at 60+/-2deg C.
3	External Short Circuit	No leakage, smoke, ignition or rupture	Preprocessing: Charge up device to rated peak voltage at 25degC Connect plus and minus terminals by external resistance of 80+/- 20mohm. Temperature: 60degC.
4	Heating	No smoke, no ignition.	Preprocessing: Charge up to peak rated voltage at 25degC. Allow capacitor to sit at 150degC for 3 hours
5	Static Electricity Test (ESD)	No leakage, smoke, ignition or rupture	<HBM>C=150pF, R=150ohm, 1kV, 10 times Test Object: balance terminal, plus terminal, upper and under sides of package Temperature: 25degC

10. Quality Assurance

- (1) Murata's responsibility for the quality of this product shall be limited to the specifications and usage as stated in this document.
- (2) The customer should evaluate and decide on the right type of assembly process and operating conditions/environment for this product.
- (3) Please keep device in sealed plastic package before use.

11. CAUTION

11.1 Limitation of Usage

This product is designed for standard consumer applications. For the following high reliability applications, please contact Murata beforehand to discuss limitations and restrictions. Wrongful use of this product could lead to malfunction and harm to human life or property.

- (1)Aviation machinery (2) Space machinery (3) Undersea machinery
- (4)Power plant control equipment (5)Transportation equipment (car, train, ship...etc.)
- (6)Signal machinery for traffic (7)Disaster prevention/crime prevention machinery
- (8) Other equivalent machinery

Please do not use this product for any applications related to the followings.

- (1)Military equipment (2) Medical Equipment

Specification of Electrical Double Layer Capacitor

11.2 STORAGE CONDITIONS

11.2.1 Storage condition without opening outer package.

30degC 60%RH for 1 year (before opening outer package)

*Remark: This product cannot be baked.

11.2.2 Storage conditions after opening outer package.

(1)Term of warranty of this device is 3 months after opening sealed package.

(2)Storage environment

Please keep device under the following conditions in sealed package.

Temperature: 5-35 deg C and

Humidity: no more than 70%RH. No condensation.

Avoid any acidic or alkaline environment.

Avoid excessive external force on this device while in storage.

(3)Please keep device in sealed plastic package before use

(4)Please do not apply any heat treatment before use.

11.3. CAUTION BEFORE USAGE

(1) Rated voltage

This device must be used within rated voltage. In case over voltage, electrolyte leakage or swelling may occur.

This device has two individual cells connected electrically in series. Please make sure that peak voltage is less than 2.7V per cell and less than 2.1V per cell for constant load.

(2)Balance control

When connecting 2 or more capacitors in series (This device itself consists of two individual capacitors connected electrically in series.), please make sure to control voltage balance of each capacitor for the following two purposes;

- To prevent overvoltage: Prevent excessive voltage from being applied to any capacitor
- To prevent shortening of the life time: By making capacitor voltage equal, variation in the rate of degradation can be controlled. It allows long-term use of capacitors.

<Recommended balance condition>

	Discharge Frequency of capacitor (Under the condition of power-off (fully discharge) or discharge under 0.5V)				Discharge at under 0.3V (Battery assist)
	under 10 times	10-100times	100-500 times	500times or more	
2.5V/cell or more	active balance	active balance	active balance	active balance	active balance
2.3-2.5V/cell	220kΩ or less	100kΩ or less	10kΩ or less	4.7kΩ or less	220kΩ or less
2.1-2.3V/cell	220kΩ or less	220kΩ or less	10kΩ or less	10kΩ or less	220kΩ or less
1.8-2.1V/cell	220kΩ or less	220kΩ or less	22kΩ or less	22kΩ or less	220kΩ or less
under1.8V/cell	Please consult a Murata representative				

Supposed condition: Temperature is always under 50degC. Within five years

(Supposed degradation rate;

Capacitance decrease: up to 30%, ESR increase: up to 50%)

If using capacitor always at over 50degC, please consult a Murata representative.

Specification of Electrical Double Layer Capacitor

(3) Applicable wave form

Fig 1. Permitted loading.

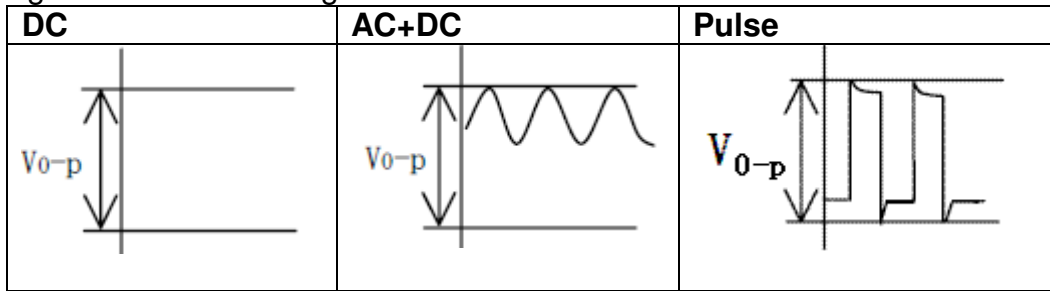
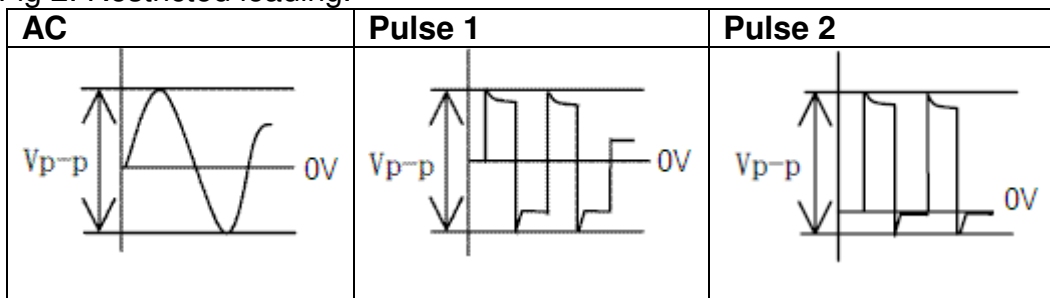

Fig 2. Restricted loading.



<Polarity>

This device has polarity. Please do not reverse polarity when in use.

Reverse polarity may damage electrolyte or the electrode inside.

Please verify the orientation of the capacitor before use in accordance with the Markings of polarity on the products.

(4). Self heating temperature

The product temperature should not exceed 70degC, including any self heating due to high currents and ESR (ohmic losses). When measuring temperature, a $\phi 0.1\text{mm}$ type K thermocouple of low heat capacity is recommended. Self heating temperature should be measured under no radiation heat from tabs and wind-free condition. Excessive heating may decrease the reliability of the product or damage it irreversibly.

(5). If a capacitor body contacts with other part or circuit, it may cause leakage failure.

(6). This device cannot be used under any acidic or alkaline environment.

(7). This device uses a relatively low vapor pressure liquid electrolyte. At high altitudes (low external pressure), internal resistance or other performance may be decreased. If you would like to use this product at high altitude continuously, please consult a Murata representative first.

11.4. CAUTION for Soldering and Assembling

(1) These parts should not be soldered using Re-Flow and Flow profiles. Please use connection methods which prevent the main body of the parts rising beyond maximum allowable temperature. These may include hand soldering, Ultrasonic welding, etc

(2) Please do not apply excessive force to the capacitor during insertion as well as after soldering. The excessive force may result in damage to electrode terminals and/or degradation of electrical performance.

Specification of Electrical Double Layer Capacitor

(3) Hand Soldering

Please solder under following conditions.

Soldering iron temperature at 350 deg C +/-10 deg C

Solder Iron wattage: 70W or less

Soldering time: Within 5 sec per one terminal

Allowable soldering frequencies: 3 times /device.

* Please allow at least for 15 sec between successive soldering per one terminal.

Please do not touch laminate package directly by solder iron.

In order to ensure the connectivity, please apply preparatory solder on the land.

When soldering, please apply flux or flux solder, heating the preparatory solder.

(4) Please refer to figure below for designing land pattern.

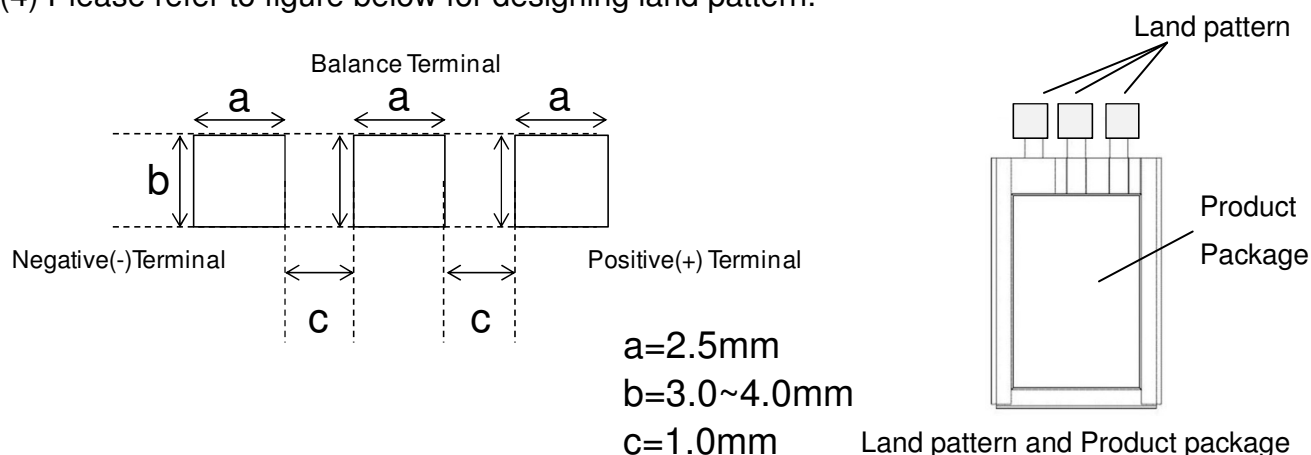

(5) Please do not wash the device after soldering.

11.5. Disassembly

This device uses a volatile organic electrolyte. Please do not disassemble it.

11.6. Disposal

This device should be disposed of as industrial waste in accordance with local laws and regulations. Never throw this device into fire.

11.7. Response to IATA Dangerous Goods Regulations

According to 54th Edition of IATA Dangerous Goods Regulations effective from January 1, 2013, Electrical Double Layer Capacitor (ELDC) with an energy storage capacity greater than 0.3 Wh is treated as dangerous goods and introduced as UN3499 in Class 9.

However, an energy storage capacity of each Murata's EDLCs is not greater than 0.3 Wh. Therefore, Murata's EDLCs are not covered by this regulation.

12. Proposal

- (1) When you use, please evaluate in a state mounted by your product.
- (2) Please do not use this product other than the mentioned contents of this specification.
- (3) Please return us a copy after sealing with your company receipt stamp in this specification.
- (4) We think that it is not appropriate to mention a contract matter about the business in specifications, a drawing and other technical documentations.
- (5) This document specifies technical and quality specifications. No warranties or liabilities are implied implicitly or explicitly in this document. These matters should be handled elsewhere.

13. Performance Data

13.1. Leakage current (Typical)

Shows how leakage current decays with time as below.

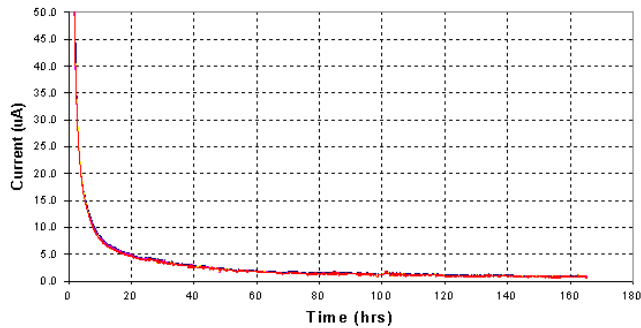

13.2. Temperature performance

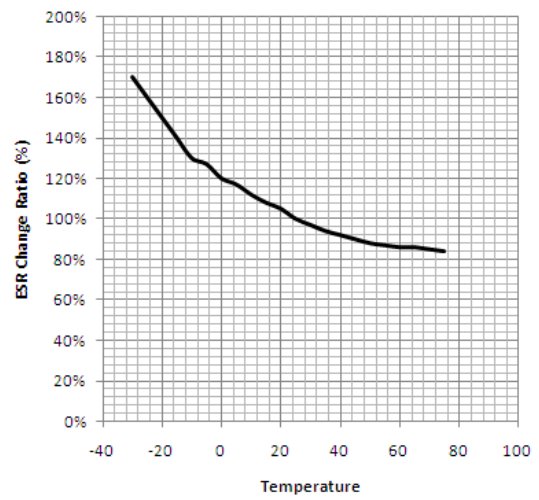
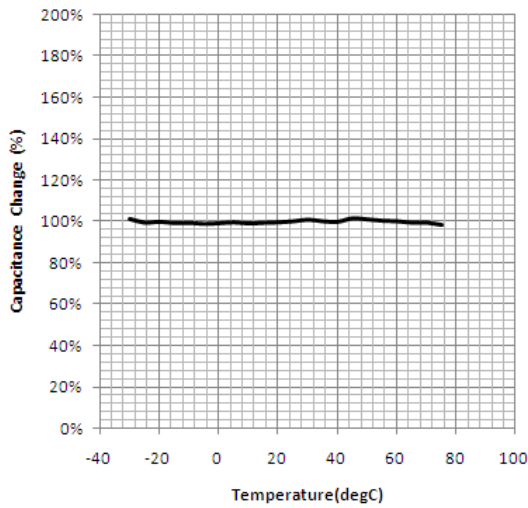

13.3. Discharge characteristic

