

# PCL-832

## 3-axis Servo Motor Control Card

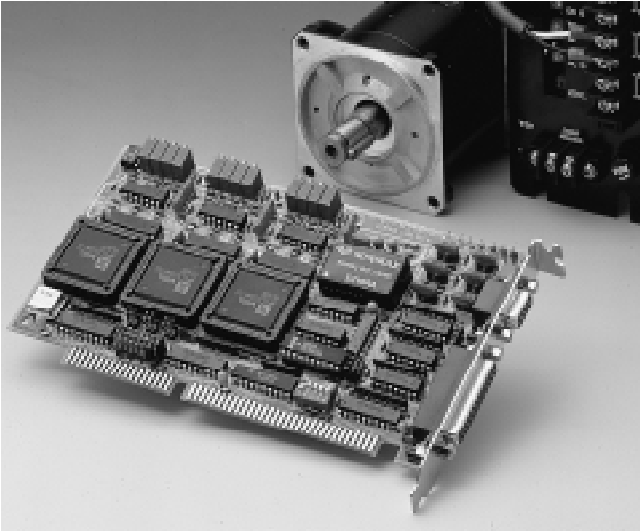

### Features

- Independent 3-axis servo control
- 3-axis linear interpolation
- 2-axis circular interpolation
- 1 msec. servo update time
- Easy programming from C and other high-level languages
- Six axes maximum in one PC system
- Half-size AT (ISA bus) add-on card
- 12-bit analog output with  $\pm 10$  V range
- Built-in F/V converter

### Introduction

The PCL-832 3-axis Servo Motor Control Card turns your IBM PC or compatible computer into a sophisticated position controller. The card's custom ASIC implementation provides high performance at an affordable price.

The PCL-832 uses digital differential analysis techniques to implement position control. Each axis has its own position control chip, allowing complete independent control of up to three servo motors.

A special synchronization circuit synchronizes all three axes simultaneously. The card can supply a simulated tachometer output to the servo motor driver. This signal makes a tachometer unnecessary in some applications, reducing overall system costs.

The PCL-832's programming library (accessible from C) supports high-level commands and functions, making control easy. The library includes commands to set the DDA cycle time and acceleration/deceleration curve as well as functions for linear interpolation, circular interpolation, return home and jog.

### Application

- Precise position control
- Robotics control
- Machine control with up to three axes
- PC-based NC controller

### Specifications

- **No. of axes:** 3 independent axes
- **Control algorithm:** Proportional control
- **Positional accuracy:**  $\pm 1$  quadrature count
- **Effective travel length:** No limit
- **Output type:** 12-bit D/A,  $\pm 10$  V full scale
- **Servo update time:** 1 msec. to 2 sec. (programmable)
- **Error counter:**  $\pm 12$  bit
- **Tachometer simulation output (F/V converter):**  $\pm 10$  V at 250 kHz (default), VR adjustable
- **Home sensor input:** 1 channel per axis
- **Encoder input:** Single-ended or differential
- **Counts per encoder cycle:** x1, x2, x4 (jumper selectable)
- **Max. quadrature input freq.:** 250 kHz

### General

- **Bus:** 16-bit AT (ISA bus)
- **IRQ:** 2, 3, 5, 7, 10, 11, 12 or 15
- **I/O addresses:** 32
- **Power consumption:** 5 V @ 500 mA max.  
12 V @ 200 mA max.
- **Operating temperature:** 0 ~ +60° C (32 ~ 140° F)
- **Storage temperature:** -20 ~ +70° C (-4 ~ 158° F)
- **Operating humidity:** 5 ~ 95% RH non-condensing (refer to IEC 68-2-3)
- **Connector:** DB-9 connector for servo control  
DB-25 connector for encoder and home signals
- **Dimensions:** 185 mm (L) x 100 mm (H) (7.3" x 3.9")

## Programming the PCL-832

The PCL-832 comes with a command and control library that you link into your C/C++ program. You can use high-level commands instead of assembly language. The library supports the following functions:

- **System functions:** Initialize and shut down the PCL-832
- **Operating functions:** Set card parameter (e.g., DDA cycle time), read error counter, set acceleration/deceleration step, set feed rate, set absolute/relative coordinates, etc.
- **Movement functions:** Go to home position, linear/circular interpolation, jog, etc.
- **Miscellaneous functions:** Hold, abort, continue, read position, etc.

## Block Diagram

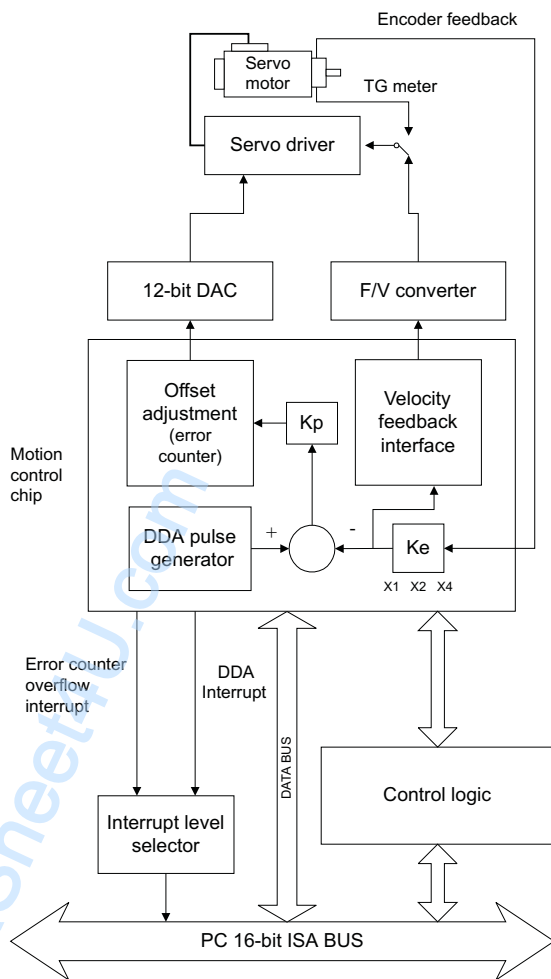

## Pin Assignments

### Servo Control

V <sub>CMD</sub> (CH1)	1	F/V (CH1)
AGND	2	V <sub>CMD</sub> (CH2)
F/V (CH2)	3	AGND
V <sub>CMD</sub> (CH3)	4	F/V (CH3)
AGND	5	

V<sub>CMD</sub>: Voltage command output

F/V: Frequency/voltage converter output

AGND: Analog ground

### Encoder and Home Sensors

DGND	1	14	A+ (CH1)
A- (CH1)	2	15	B+ (CH1)
B- (CH1)	3	16	INDEX+ (CH1)
INDEX- (CH1)	4	17	HOME (CH2)
DGND	5	18	A+ (CH2)
A- (CH2)	6	19	B+ (CH2)
B- (CH2)	7	20	INDEX+ (CH2)
INDEX- (CH2)	8	21	HOME (CH2)
DGND	9	22	A+ (CH3)
A- (CH3)	10	23	B+ (CH3)
B- (CH3)	11	24	INDEX+ (CH3)
INDEX- (CH3)	12	25	HOME (CH3)
DGND	13		

A+: Encoder input (differential +)

A-: Encoder input (differential -)

B+: Encoder input (differential +)

B-: Encoder input (differential -)

INDEX+: Index input (differential +)

INDEX-: Index input (differential -)

HOME: Home sensor input (single ended)

## Ordering Information

- **PCL-832:** 3-axis servo motor control card, command library and user's manual
- **ADAM-3925:** DB-25 wiring terminal for DIN-rail mounting