



STCF07

High power buck-boost white LED driver

Features

- Buck-boost DC-DC converter
- Drives one power LED up to 1 A in flash mode
- Drives one power LED up to 800 mA in continuous mode
- LED temperature protection
- Output current control
- 1.8 MHz (typ.) fixed frequency PWM
- Synchronous rectification
- High efficiency across the total input voltage range
- Operational modes:
 - Shutdown mode
 - High current mode: up to 1 A
 - Low current mode: from 20 mA
- Adjustable current in both modes
- Peak inductor limited to 2.3 A (typ.)
- LED disconnected from the battery in shutdown mode
- NTC LED temperature protection
- Overvoltage protection: 5.3 V
- Short-circuit protection
- Overtemperature protection
- ULVLO function
- 1 μ A max shutdown current
- QFN16 (4 x 4 x 1 mm) 16 leads

Applications

- Camera flash for mobile phones
- Power supply for high power LEDs

Table 1. Device summary

Order code	Package	Packaging
STCF07PNR	QFN16 (4 x 4 mm)	Tape and reel

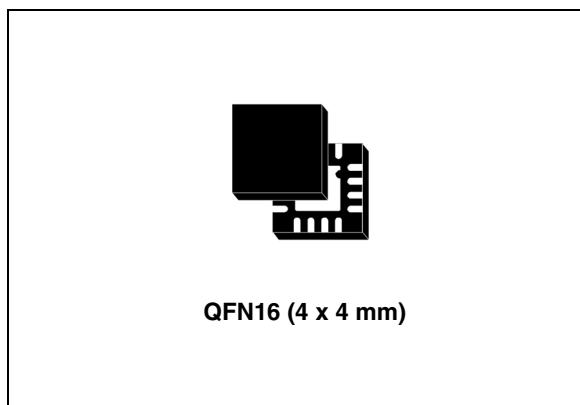

Description

The STCF07 is a dedicated, size-optimized solution for driving a power LED. The device is a buck-boost converter which guarantees proper LED current control over all possible battery voltage and LED forward voltage conditions. The output current control ensures good current regulation over the forward voltage spread characteristics of high-brightness LEDs.

The device includes various functions to protect the chip and the power LEDs. These include soft-start control as well as detection and protection of chip overtemperature and shorted LEDs. An optional external NTC is supported to protect the LEDs against overheating. It is possible to separately program the current intensity in HIGH and LOW mode using the SEL pin. The device is housed in a 16-lead QFN16 (4 x 4 mm) package with a height less than 1 mm.

Contents

1	Block diagram	4
2	Pin configuration	5
3	Maximum ratings	6
4	Application information	7
5	Electrical characteristics	8
6	Introduction	10
7	Logic pin description	11
	7.1 CSEL pin	11
	7.2 FAULT pin	11
	7.3 ENABLE pin	11
8	Detailed description	12
	8.1 Buck-boost converter	12
	8.2 High current mode	12
	8.3 Low current mode	12
	8.4 Shutdown mode	12
	8.5 Soft-start	12
	8.6 STCF07 protection features	13
	8.6.1 Peak current and short-circuit protection	13
	8.6.2 Overvoltage protection	13
	8.6.3 Thermal shutdown protection	13
	8.6.4 Sensing of LED temperature with the NTC resistor	13
	8.6.5 Undervoltage lockout function	14
9	PCB design	15
	9.1 PCB design rules	15
	9.2 PCB design of the demonstration board	16
	9.3 Schematic of the demonstration board	18

10	Typical performance characteristics	19
11	External component selection	20
	11.1 Input and output capacitor selection	20
	11.2 Inductor selection	20
	11.3 LED selection	20
	11.4 RHC selection	20
	11.5 RLC selection	21
	11.6 NTC and RX resistor selection	21
12	Package mechanical data	22
13	Revision history	25

1 Block diagram

Figure 1. STCF07 block diagram

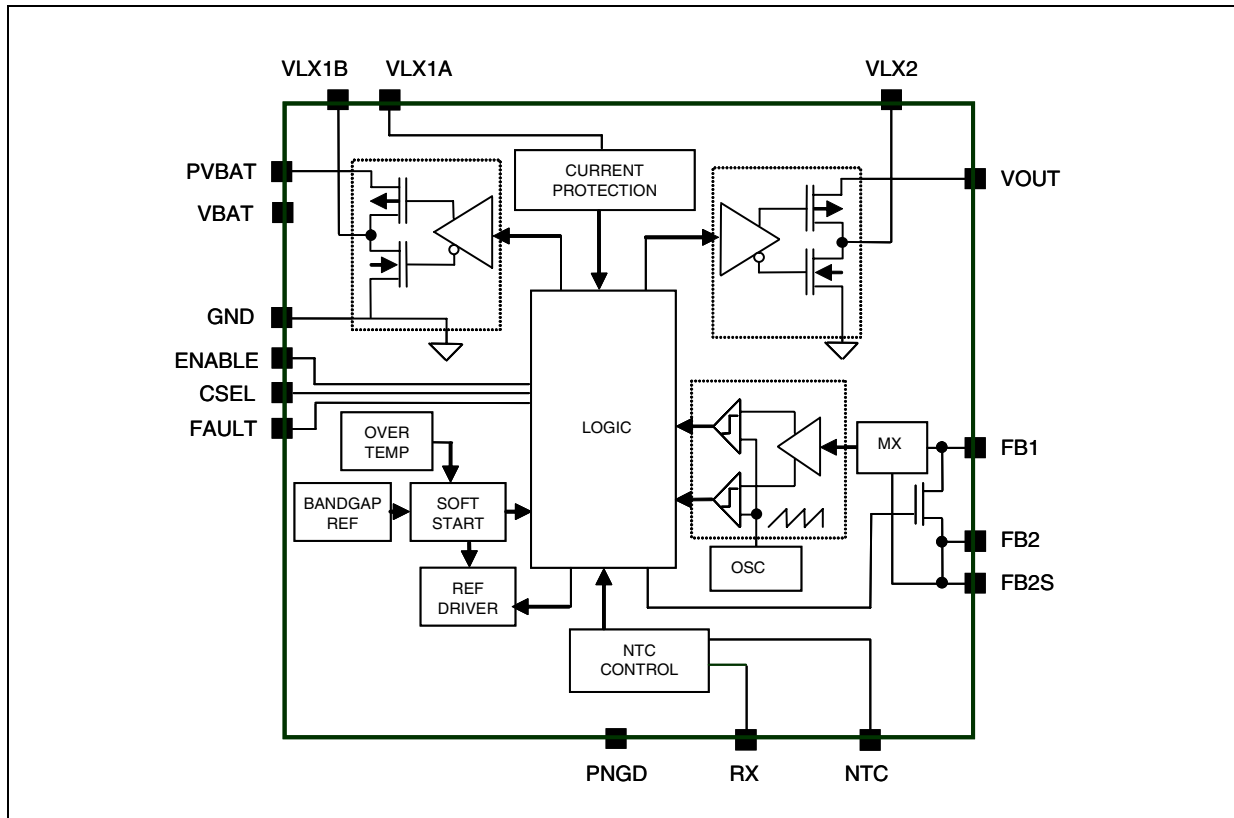

2 Pin configuration

Figure 2. STCF07 pin connections (top view)

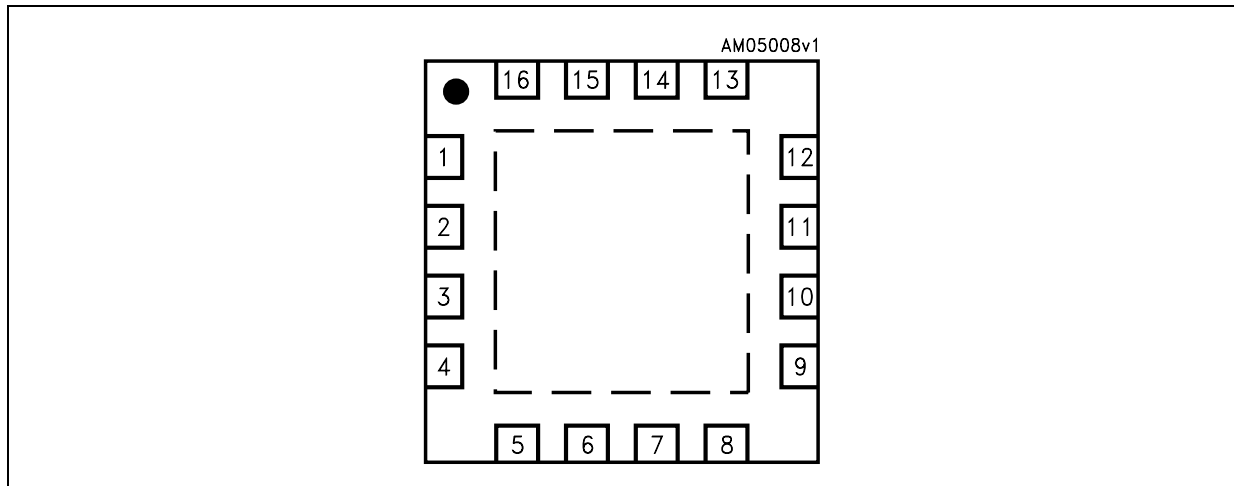

Table 2. STCF07 pin description

Pin n°	Symbol	Description
1	VLX2	Inductor VLX2 connection
8	RX	R_X resistor connection
2	NTC	NTC resistor connection
3	VOUT	Output voltage
4	FB1	Feedback pin [$I_{LED} \cdot (R_{HC} + R_{LC})$]
5	FB2	R_{TR} bypass
6	FB2S	Feedback pin [$I_{LED} \cdot R_{HC}$]
14	GND	Signal ground
13	CSEL	Current selection
7	EN	Enable
16	FAULT	Diagnostic
9	PVBAT	Power supply voltage
10	VBAT	Supply voltage
11	VLX1A	Inductor VLX1 connection
12	VLX1B	Inductor VLX1 connection
15	PGND	Power ground
Exposed pad	PGND	To be connected to the PCB ground plane for optimal electrical and thermal performance

3 Maximum ratings

Table 3. Absolute maximum ratings

Symbol	Parameter	Value	Unit
VBAT	Signal supply voltage	-0.3 to 6	V
PVBAT	Power supply voltage	-0.3 to 6	V
VLX1A, VLX1B	Inductor connection 1	-0.3 to $V_I+0.3$	V
VLX2	Inductor connection 2	-0.3 to $V_I+0.3$	V
VOUT	Output voltage	-0.3 to 6	V
FB1, FB2, FB2S	Feedback and sense voltage	-0.3 to 3	V
R _X	Connection for reference resistor	-0.3 to 3	V
CSEL	Current selection	-0.3 to $V_I+0.3$	V
EN	Enable	-0.3 to $V_I+0.3$	V
FAULT	Diagnostic	-0.3 to $V_I+0.3$	V
NTC	Connection for LED temperature sensing	-0.3 to 3	V
ESD	Human body model	±2	kV
P _{TOT}	Continuous power dissipation (at T _A = 70 °C)	800	mW
T _{OP}	Operating junction temperature range	-40 to 85	°C
T _J	Junction temperature	-40 to 150	°C
T _{STG}	Storage temperature range	-65 to 150	°C

Note: Absolute maximum ratings are those values beyond which damage to the device may occur. Functional operation under these condition is not implied.

Table 4. Thermal data

Symbol	Parameter	Value	Unit
R _{thJA} ⁽¹⁾	Thermal resistance junction-ambient	31	°C/W

1. Junction-to-ambient thermal resistance in JEDEC still air chamber. Thermal test board JESD51-7 (lead surface mount packages).

4 Application information

Figure 3. Application schematic diagram

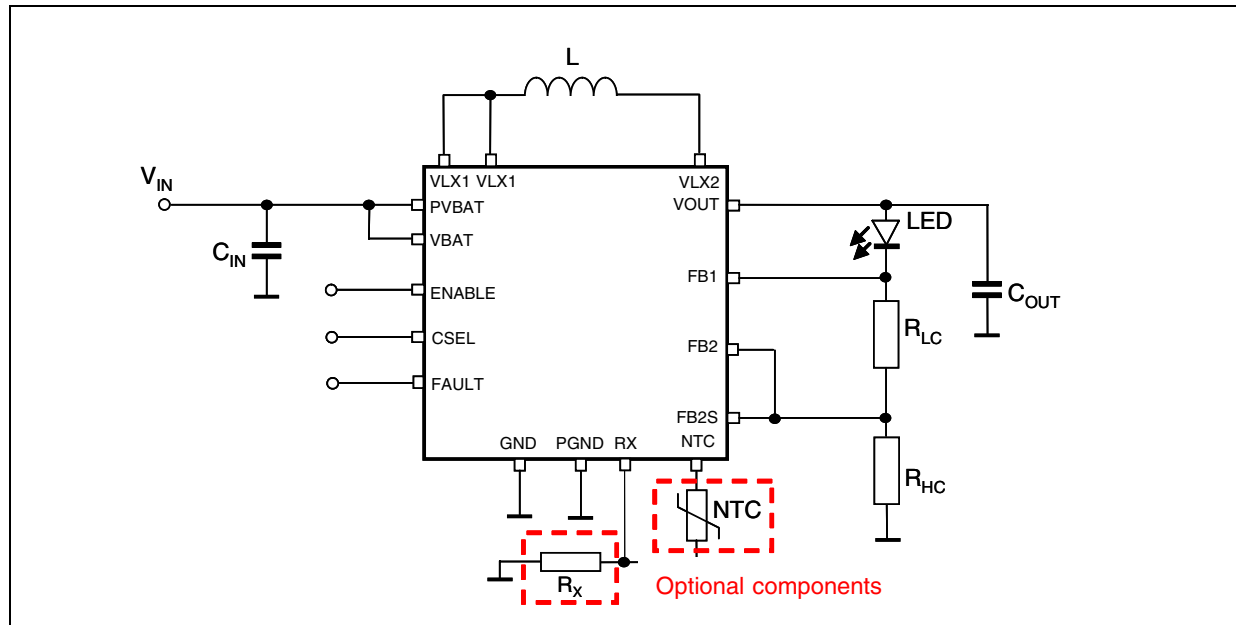

Note: Represents a typical application schematic for an output current of 800 mA (max) in continuous mode operation. For pulse/flash mode operation it is possible to increase the maximum output current up to 1 A. If the battery voltage is higher than 3.1 V, the chip is capable of delivering the maximum output current of up to 1 A in continuous mode.

Table 5. List of external components

Component	Manufacturer	Part number	Value	Size
R _{HC}	Welwyn	LR1206-R20FI ⁽¹⁾	0.2 Ω	1206
	KOA	SR732BTTDR160F ⁽²⁾	0.16 Ω	1206
R _{LC}	Tyco Electronics	CRL1220T1R8J	1.8 Ω	0805
C _{IN}	TDK	C1608X5R0J106MT	10 μF	0603
C _{OUT}	TDK	C1608X5R0J475M	4.7 μF	0603
L	TDK	VLF4014S-4R7M1R4 ⁽¹⁾	4.7 μH / 1.4 A	3.5x3.8x1.4 mm
		VLF5014S-2R2M2R3 ⁽²⁾	2.2 μH / 2.3 A	4.6x4.8x1.4 mm
NTC	MURATA	NCP18WF104J03RB	100 kΩ	0805
R _x	Tyco Electronics	1-1879132-9	15 kΩ	0402
LED	Luxeon	LXHL_PW09		

1. For 800 mA output current performance.
2. For 1000 mA output current performance.

Note: The above-listed external components refer to a typical application. Operation of the STCF07 is not limited to the use of these components.

5 Electrical characteristics

$T_A = 25\text{ }^\circ\text{C}$, $V_I = 3.6\text{ V}$, $2 \times C_I = 10\text{ }\mu\text{F}$, $C_O = 1\text{ }\mu\text{F}$, $L = 4.7\text{ }\mu\text{H}$, $R_{HC} = 0.22\text{ }\Omega$, $R_{LC} = 1.8\text{ }\Omega$, $R_X = 15\text{ k}\Omega$

Table 6. Electrical characteristics

Symbol	Parameter	Test conditions	Min.	Typ.	Max.	Unit
V_I	Input voltage supply		2.7		5.5	V
UVLO	Undervoltage lockout	$V_I = 2.7\text{ V}$		2.2		V
$V_{PW_ONRESET}$	Power ON reset threshold	V_I rising		2.3		V
I_O	Output current - high current level	CSEL = V_I ; $V_I = 2.7\text{ V to } 5.5\text{ V}$; $R_{HC} = 0.16\text{ }\Omega$, $P_{OUT} = 3.4\text{ W}$			1000	mA
	Output current - high current level	CSEL = V_I ; $V_I = 3.2\text{ V to } 5.5\text{ V}$; $R_{HC} = 0.16\text{ }\Omega$, $P_{OUT} = 4\text{ W}$			1000	
	Output current - low current level	CSEL = GND; $V_I = 3.3\text{ V to } 5.5\text{ V}$; $R_{HC} + R_{LC} \sim 2\text{ }\Omega$	20			
V_{OUT}	Regulated voltage range		2.5		5.3	V
ILIM	Inductor peak current	$V_I = 2.7\text{ V}$, V_{OUT} shorted during operation		2.3		A
FB1	Feedback voltage	Low current (CSEL = 0 V)	152	160	168	mV
FB2	Feedback voltage	High current (CSEL = V_I)	152	160	168	mV
$R_{ON_}$	FB1-FB2 ON resistance	High current (CSEL = V_I) $I_O = 800\text{ mA}$		90		m Ω
I_Q	Quiescent current in shutdown mode	EN = GND		1		μA
	Quiescent current in high current mode	EN = V_I ; CSEL = V_I ; $V_I = 3.3\text{ V to } 5.5\text{ V}$; $R_{HC} = 0.22\text{ }\Omega$		1.8		mA
f_s	Frequency	$V_I = 2.7\text{ V}$		1.8		MHz
n	Efficiency	$V_I = 3.2\text{ to } 4.2\text{ V}$, $I_O = 800\text{ mA}$		85		%
OVP	Output overvoltage protection	$V_I = 5.5\text{ V}$, no load	5.5			V
OV_{HYST}	Overvoltage hysteresis	$V_I = 5.5\text{ V}$, no load		0.3		V
OTP	Overvoltage protection	$V_I = 5.5\text{ V}$		140		$^\circ\text{C}$
OT_{HYST}	Overvoltage hysteresis	$V_I = 5.5\text{ V}$		20		$^\circ\text{C}$
V_{NTC}	NTC voltage reference	$V_I = 2.7\text{ V to } 5.5\text{ V}$		1.8		V
V_{RX}	NTC voltage threshold	$I_{NTC} = 1\text{ mA Max}$		1.2		V
NTC_{LEAK}	RX-NTC switch OFF leakage	Shutdown mode, $V_{NTC} = 2\text{ V} - V_{RX} = \text{GND}$			1	μA
V_{IL}	Input logic signal level CSEL, EN	$V_I = 2.7\text{ V to } 5.5\text{ V}$	0		0.4	V
V_{IH}			1.4		3	

STCF07

Electrical characteristics

Table 6. Electrical characteristics (continued)

Symbol	Parameter	Test conditions	Min.	Typ.	Max.	Unit
FAULT	Low level voltage	$I_{\text{SINK}} = 5 \text{ mA}$		0.2	0.5	V
	Leakage current	$V_{\text{FAULT}} = 5 \text{ V}$		1		μA
T_{ON}	LED current rise time $I_{\text{LED}} = 0$ to $I_{\text{LED}} = \text{max}$				2	ms

6 Introduction

The STCF07 is a buck-boost converter designed to power and control the current of a power white LED. The device operates at a constant switching frequency of 1.8 MHz (typ). It provides an output voltage from 2.5 V up to 5.3 V, from a 2.7 V to 5.5 V supply voltage. This supply range allows the device to operate from a single-cell Lithium-Ion battery. The current is adjustable up to 1 A for an input voltage ranging from 2.7 V to 5.5 V and maximum output power up to 3.4 W. When the battery voltage is higher than 3.2 V, it is possible to increase the output power up to 4 W. The device uses an external NTC resistor to sense the temperature of the white LED. This function may not be needed in all applications, and in these cases the relevant external components can be omitted.

7 Logic pin description

7.1 CSEL pin

This input pin allows the setting of two different levels of current. When the voltage on this pin is low, the internal multiplexer switches the feedback to the FB1 pin, which is the dedicated feedback pin for low current operation. When the voltage on the CSEL pin is high, the internal multiplexer switches the feedback to the FB2s pin, and enables the shorting transistor connected between the FB1 and FB2 pins. The feedback voltage is sensed directly on the sensing R_{HC} by the connection of FB2s. This sensing pin is dedicated to high current operation.

7.2 FAULT pin

When the STCF07 is in ON mode (EN is high), the device is able to detect disconnection or failure of the LED. This information can be used by the system to signal that a problem has occurred in the LEDs.

7.3 ENABLE pin

This pin functions as an enable input. No internal pull-up or pull-down is provided.

8 Detailed description

8.1 Buck-boost converter

The regulation of the PWM controller is done by sensing the current of the LED through R_{LC} or $R_{LC} + R_{HC}$, depending on the CSEL voltage. Depending of the forward voltage of the flash LED, the device can automatically change between buck (step-down) and boost (step-up) mode:

- Boost region = $V_{OUT} > V_{BAT}$: this configuration is used in most cases, as the output voltage ($V_{OUT} = V_F + I_{LED} \times R_{SENSE}$) is higher than V_{BAT}
- Buck region = $V_{OUT} < V_{BAT}$
- Buck / boost region = $V_{OUT} \sim V_{IN}$

8.2 High current mode

ENABLE = CSEL = V_{BAT}

The STCF07 operates continuously to supply maximum current to the LED up to 800 mA in high current mode. If high current mode is used in flash applications, then it is possible to increase the LED current up to 1066 mA.

The current can be adjusted with the R_{HC} resistor. The current is then programmed at:

$$I_{HC} = 160 \text{ mV} / R_{HC}$$

For a current programmed at 800 mA, the sensing resistor is equal to 0.20 Ω .

8.3 Low current mode

ENABLE = V_{BAT} , CSEL = 0

The STCF07 can continuously provide an adjustable current starting from 20 mA in low current mode. The current adjustment is done with resistor R_{LC} . The current is then programmed at:

$$I_{LC} = 160 \text{ mV} / (R_{HC} + R_{LC})$$

The NTC divider for measurement of the LED temperature is active.

8.4 Shutdown mode

ENABLE = 0

When the device is not used, it can be put in shutdown mode, which reduces the quiescent current to 1 μA . The NTC protection in this mode is not active.

8.5 Soft-start

To avoid spikes on the battery during the startup sequence, a soft-start function has been implemented. The soft-start function is achieved by progressively increasing the feedback voltage reference. In worst-case conditions, the startup time, as defined below ($I_{OUT} = I_{MAX}$), does not exceed 2 ms.

Figure 4. Startup: LED current rise time

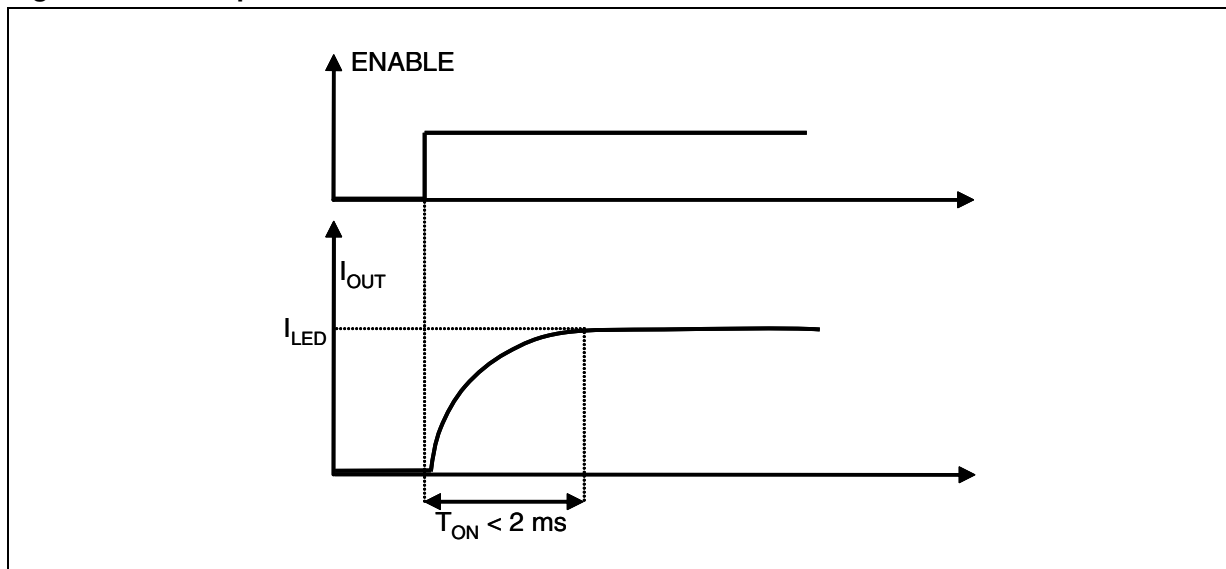

8.6 STCF07 protection features

8.6.1 Peak current and short-circuit protection

When the peak inductor current exceeds the maximum switch peak current limit of 2.3 A, the PWM controller turns off and is enabled at the next oscillation period.

8.6.2 Overvoltage protection

The device includes power failure protection, which stops the operation of the PWM controller when the voltage at the pin V_{OUT} exceeds the OVP threshold. When the voltage on pin V_{OUT} is reduced by OV_{HYST} , the operation of the controller recovers automatically.

www.DataSheet4U.com

8.6.3 Thermal shutdown protection

Internal thermal shutdown protection switches off the device when the junction temperature exceeds 140 °C (typ). The hysteresis comparator allows the PWM controller to restart automatically when the temperature is reduced to 120 °C.

8.6.4 Sensing of LED temperature with the NTC resistor

The device is capable of switching off the power circuit when a high temperature on the LED is detected. (see [Figure 5](#)).

Figure 5. Typical LED temperature sensing application with the NTC resistor

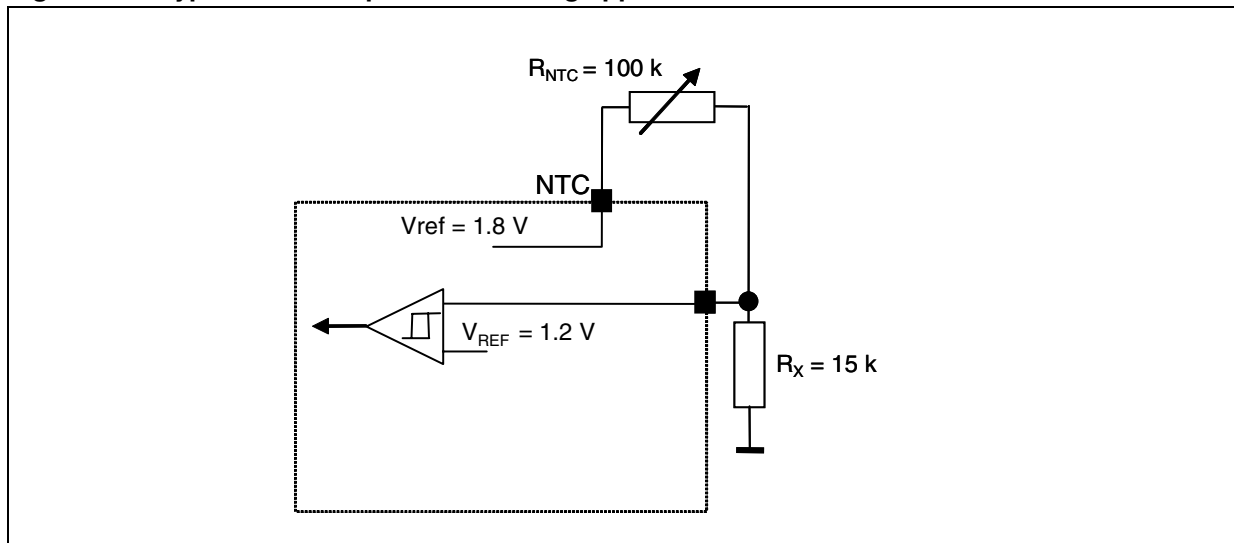

8.6.5 Undervoltage lockout function

If the device is ON and the battery voltage is as low as 2.2 V, the device goes into a FAULT state and the FAULT pin is put to LOW. To restart the device, the ENABLE pin must be reset LOW and HIGH.

9 PCB design

9.1 PCB design rules

The STCF07 is a powerful switched device, so the PCB must be designed following the rules for designing switched supplies. It is recommended to use at least a two-layer PCB. The power wiring must be as short and wide as possible, due to the high current. All external components should be placed close to the STCF07. High-energy switched loops should be as small as possible to reduce EMI. Most LEDs require cooling, which may be implemented by a defined copper area on the PCB. Use the reference guide for each LED to design the heatsink. Place the R_{FLASH} resistor as close as possible to pins 5 and 6. When a change of PCB layer is required, the number of vias must be sufficient. Place the NTC resistor as close as possible to the LED for good temperature sensing. Direct connection of GND and PGND is needed to achieve accurate output current values. The LED current should not flow through this track. Sensing of the voltage on the R_{FLASH} resistor must be done by connecting a wire directly from pin 6 to the R_{FLASH} resistor; no current flows through this track. Pins 5 and 6 must be connected to the pin of the R_{FLASH} resistor. The exposed pad must be connected to the PGND, with a track as wide as possible. It is recommended to place the copper plate, connected through the vias to the exposed pad, on the bottom layer to create a heatsink for the device. It is further recommended that the copper plate used be as large as possible to achieve optimal thermal performance.

9.2 PCB design of the demonstration board

Figure 6. Top layer

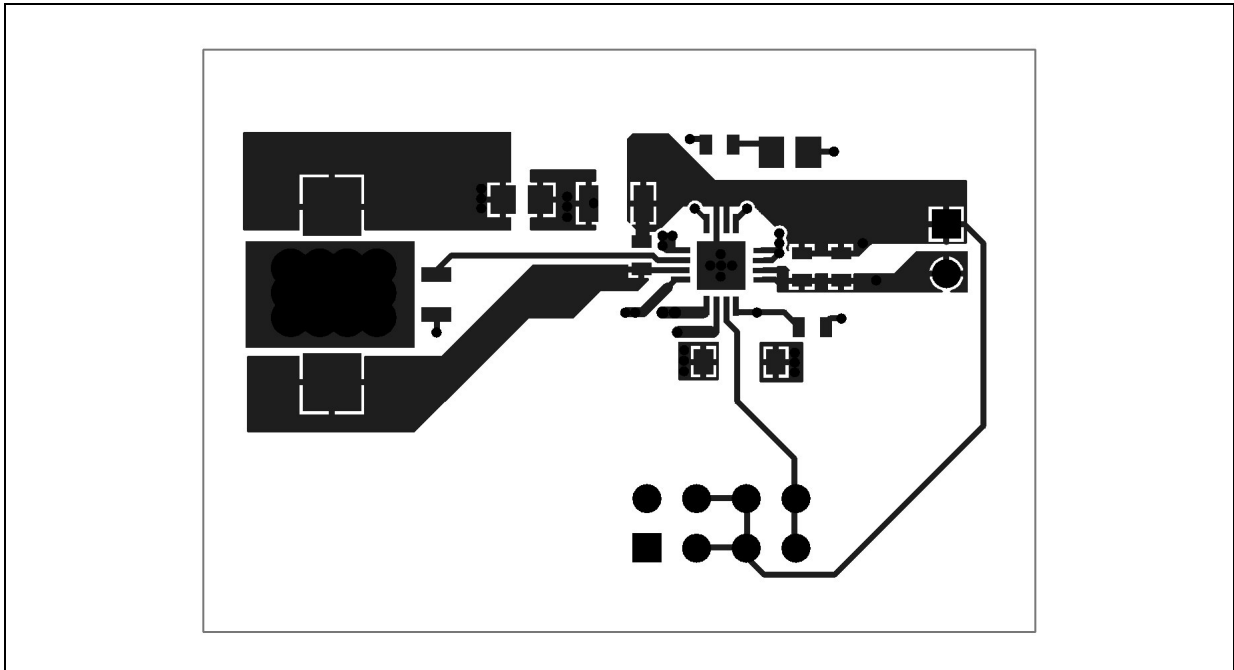
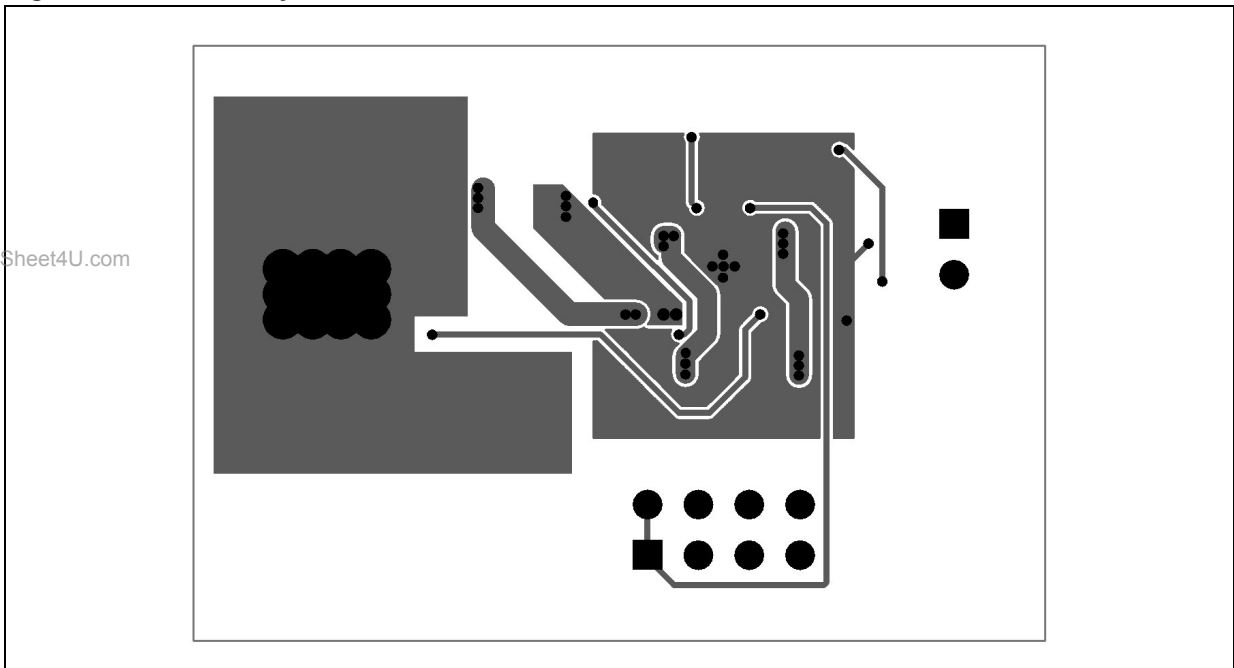
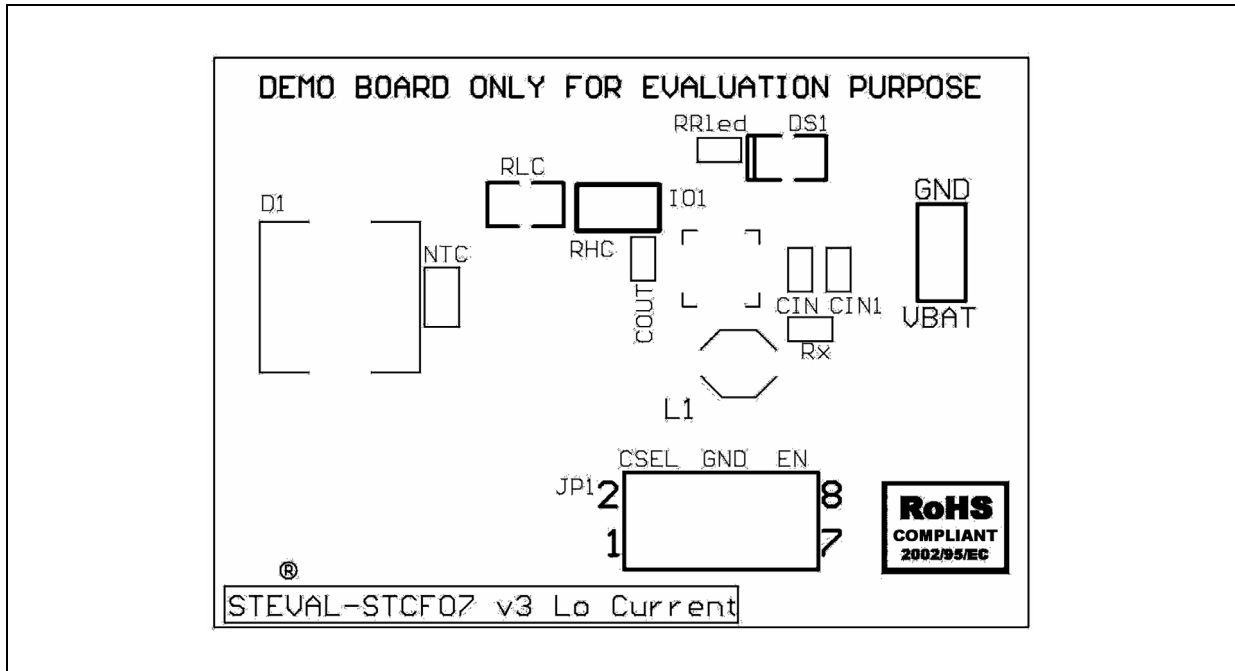

Figure 7. Bottom layer



www.DataSheet4U.com

Figure 8. Top overlay



10 Typical performance characteristics

Figure 10. I_{OUT} 80 mA vs. V_{IN}

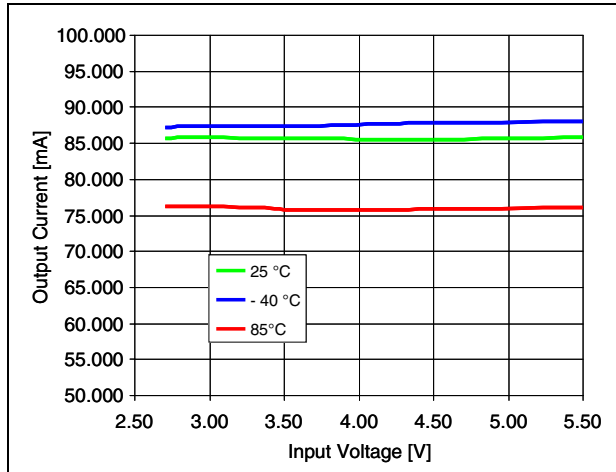

Figure 11. I_{OUT} 800 mA vs. V_{IN}

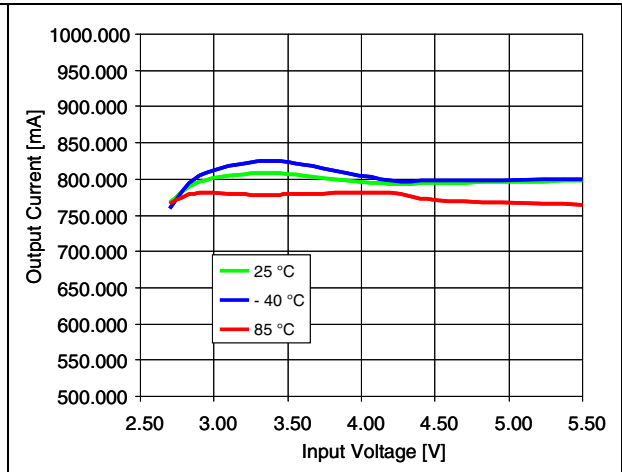

Figure 12. Efficiency vs. V_{IN}

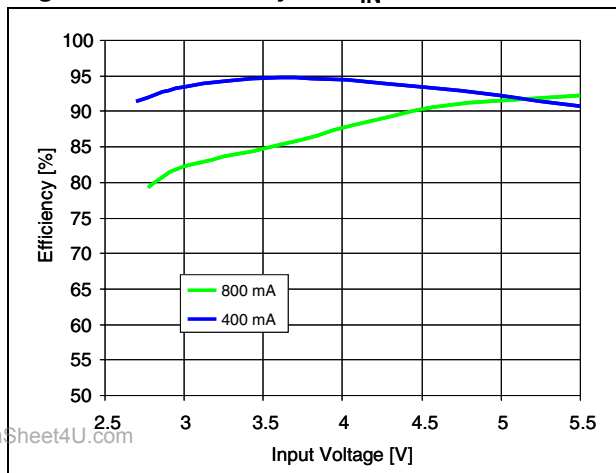

Figure 13. Efficiency vs. V_{IN} , $I_O = 400$ mA

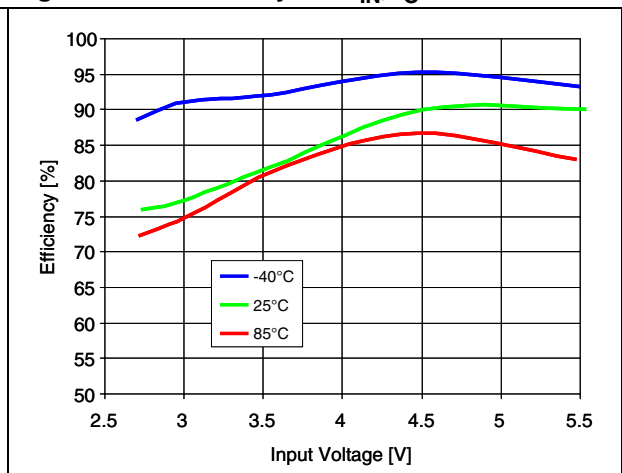
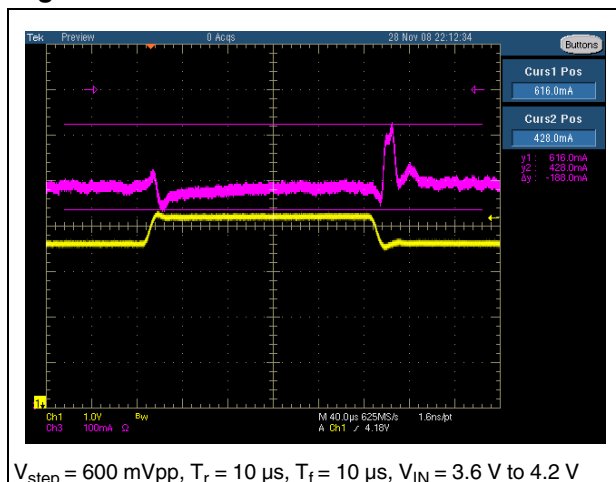

Figure 14. Line transient



11 External component selection

11.1 Input and output capacitor selection

For input and output capacitors it is recommended to use ceramic capacitors with low ESR. For good device stability when supplied by a low input voltage of 2.7 V at maximum ratings, it is recommended to use 10 μF / 6.3 V as a minimum value for the input capacitor, and 4.7 μF / 6.3 V as a minimum value for the output capacitor.

Note: See recommended components in [Table 5 on page 7](#).

11.2 Inductor selection

A thick, shielded inductor with low DC series wiring resistance is recommended for this application. For good efficiency, it is recommended to use an inductor with a series DC resistance of $R_{\text{DCL}} < R_{\text{D}} / 10$, where R_{D} is the dynamic resistance of the LED.

For nominal operation, the peak inductor current can be calculated using the formula:

$$I_{\text{PEAK}} = \left\{ (I_{\text{OUT}} / \eta) + [(V_{\text{OUT}} - V_{\text{IN}}) \times V_{\text{IN}}^2] / (2 \times L \times F \times V_{\text{OUT}}^2) \right\} \times V_{\text{OUT}} / V_{\text{IN}}$$

where:

I_{PEAK} = peak inductor current

I_{OUT} = current sourced at pin V_{OUT}

η = efficiency of the STCF07

V_{OUT} = output voltage at pin V_{OUT}

V_{IN} = input voltage at pin V_{IN}

L = inductance value of the inductor

F = switching frequency

Note: See recommended components in [Table 5 on page 7](#).

www.DataSheet4U.com

11.3 LED selection

All LEDs with forward voltages from 2.7 V to 5 V are suitable for use with STCF07 device. The LED forward voltage must include the voltage spread of this value. It is possible to set the LED current in the two different operating modes (high current mode and low current mode) through two external sensing resistors.

Note: See recommended components in [Table 5 on page 7](#).

11.4 R_{HC} selection

The R_{HC} resistor value can be calculated using equations $R_{\text{HC}} = 160 \text{ mV} / I_{\text{HC}}$ and $P_{\text{RHC}} = R_{\text{HC}} \times I_{\text{HC}}^2$, where P_{RHC} is the dissipated power on the R_{HC} resistor. It is recommended to use a 1206 package size thin metal film resistor with 1% or 5% maximum tolerance. The maximum high LED current for the STCF07 device is 800 mA with a battery voltage range 2.7 V to 5.5 V.

11.5 R_{LC} selection

R_{LC} resistor value can be calculated with the following equations:

$$R_{LC} = (160 \text{ mV} - I_{LC} * R_{HC}) / I_{LC} \text{ and } P_{RLC} = R_{LC} * I_{LC}^2$$

where P_{RLC} is the dissipated power on the R_{LC} resistor. It is recommended to use a thin metal film resistor with a 1% or 5% tolerance.

11.6 NTC and R_X resistor selection

The NTC resistor for sensing LED temperature and the R_X resistor create a voltage divider. The output of this divider is compared with the 1.192 V internal voltage reference. When voltage on the output of the voltage divider is increased over the reference, the logic switches off the power circuit. Voltage divider is possible to supply from the NTC pin, where is output of the 1.8 V internal reference.

12 Package mechanical data

In order to meet environmental requirements, ST offers these devices in different grades of ECOPACK[®] packages, depending on their level of environmental compliance. ECOPACK[®] specifications, grade definitions and product status are available at: www.st.com. ECOPACK[®] is an ST trademark.

STCF07

Package mechanical data

QFN16 (4 x 4) mechanical data

Dim.	mm.			inch.		
	Min.	Typ.	Max.	Min.	Typ.	Max.
A	0.80	0.90	1.00	31.5	35.4	39.4
A1		0.02	0.05		0.8	2.0
A2		0.65	1.00		25.6	39.4
A3		0.20			7.9	
b	0.18	0.25	0.30	7.1	9.8	11.8
D	3.85	4.00	4.15	151.6	157.5	163.4
D2	2.10		2.60	82.7		102.4
E	3.85	4.00	4.15	151.6	157.5	163.4
E2	2.10		2.60	82.7		102.4
e		0.50			19.7	
L	0.30	0.40	0.50	11.8	15.7	19.7
ddd			0.08			3.1

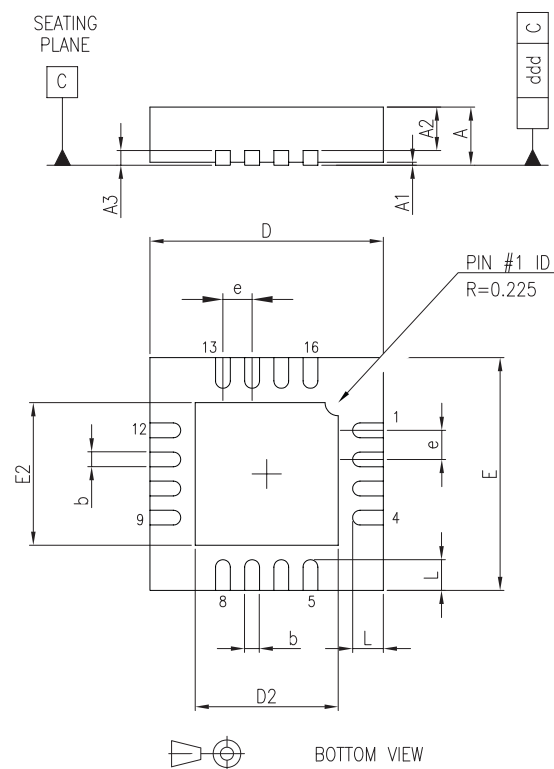

7653321A

Tape & reel QFNxx/DFNxx (4x4) mechanical data

Dim.	mm.			inch.		
	Min.	Typ.	Max.	Min.	Typ.	Max.
A			330			12.992
C	12.8		13.2	0.504		0.519
D	20.2			0.795		
N	99		101	3.898		3.976
T			14.4			0.567
Ao		4.35			0.171	
Bo		4.35			0.171	
Ko		1.1			0.043	
Po		4			0.157	
P		8			0.315	

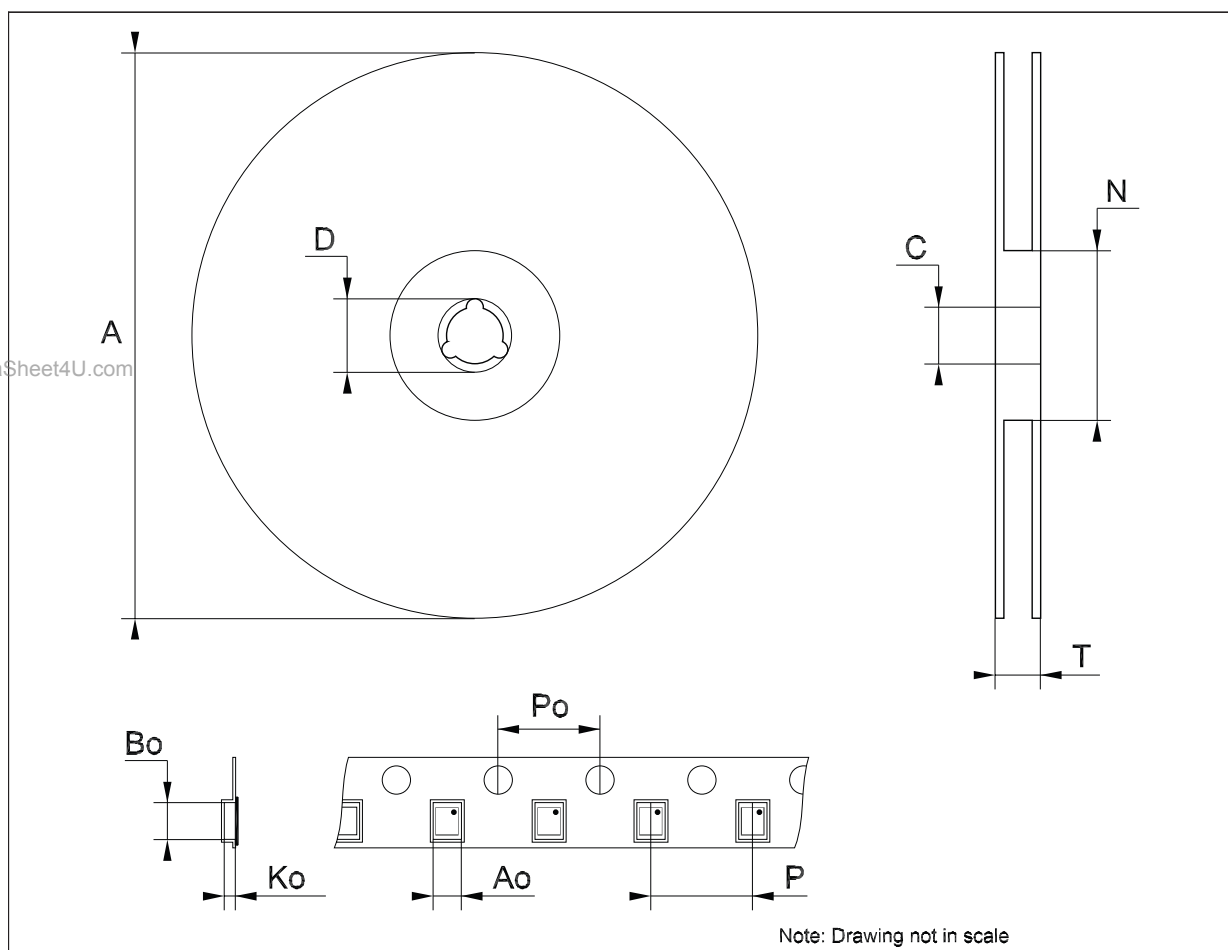

13 Revision history

Table 7. Document revision history

Date	Revision	Changes
18-Nov-2009	1	First release.

Please Read Carefully:

Information in this document is provided solely in connection with ST products. STMicroelectronics NV and its subsidiaries ("ST") reserve the right to make changes, corrections, modifications or improvements, to this document, and the products and services described herein at any time, without notice.

All ST products are sold pursuant to ST's terms and conditions of sale.

Purchasers are solely responsible for the choice, selection and use of the ST products and services described herein, and ST assumes no liability whatsoever relating to the choice, selection or use of the ST products and services described herein.

No license, express or implied, by estoppel or otherwise, to any intellectual property rights is granted under this document. If any part of this document refers to any third party products or services it shall not be deemed a license grant by ST for the use of such third party products or services, or any intellectual property contained therein or considered as a warranty covering the use in any manner whatsoever of such third party products or services or any intellectual property contained therein.

UNLESS OTHERWISE SET FORTH IN ST'S TERMS AND CONDITIONS OF SALE ST DISCLAIMS ANY EXPRESS OR IMPLIED WARRANTY WITH RESPECT TO THE USE AND/OR SALE OF ST PRODUCTS INCLUDING WITHOUT LIMITATION IMPLIED WARRANTIES OF MERCHANTABILITY, FITNESS FOR A PARTICULAR PURPOSE (AND THEIR EQUIVALENTS UNDER THE LAWS OF ANY JURISDICTION), OR INFRINGEMENT OF ANY PATENT, COPYRIGHT OR OTHER INTELLECTUAL PROPERTY RIGHT.

UNLESS EXPRESSLY APPROVED IN WRITING BY AN AUTHORIZED ST REPRESENTATIVE, ST PRODUCTS ARE NOT RECOMMENDED, AUTHORIZED OR WARRANTED FOR USE IN MILITARY, AIR CRAFT, SPACE, LIFE SAVING, OR LIFE SUSTAINING APPLICATIONS, NOR IN PRODUCTS OR SYSTEMS WHERE FAILURE OR MALFUNCTION MAY RESULT IN PERSONAL INJURY, DEATH, OR SEVERE PROPERTY OR ENVIRONMENTAL DAMAGE. ST PRODUCTS WHICH ARE NOT SPECIFIED AS "AUTOMOTIVE GRADE" MAY ONLY BE USED IN AUTOMOTIVE APPLICATIONS AT USER'S OWN RISK.

www.DataSheet4U.com

Resale of ST products with provisions different from the statements and/or technical features set forth in this document shall immediately void any warranty granted by ST for the ST product or service described herein and shall not create or extend in any manner whatsoever, any liability of ST.

ST and the ST logo are trademarks or registered trademarks of ST in various countries.

Information in this document supersedes and replaces all information previously supplied.

The ST logo is a registered trademark of STMicroelectronics. All other names are the property of their respective owners.

© 2009 STMicroelectronics - All rights reserved

STMicroelectronics group of companies

Australia - Belgium - Brazil - Canada - China - Czech Republic - Finland - France - Germany - Hong Kong - India - Israel - Italy - Japan - Malaysia - Malta - Morocco - Philippines - Singapore - Spain - Sweden - Switzerland - United Kingdom - United States of America

www.st.com