



UZ1086

LINEAR INTEGRATED CIRCUIT

1.5A ADJUSTABLE/FIXED LOW DROPOUT LINEAR REGULATOR

DESCRIPTION

The UTC **UZ1086** and **UZ1086**-1.8V, 2.5V, 2.85V, 3.3V and 5V are low dropout three-terminal regulators with 1.5A output current capability. These devices have been optimized for low voltage where transient response and minimum input voltage are critical. The 2.85V version is designed specifically to be used in Active Terminators for SCSI bus.

Current limit is trimmed to ensure specified output current and controlled short-circuit current. On-chip thermal limiting provides protection against any combination of overload and ambient temperatures that would create excessive junction temperatures.

Unlike PNP type regulators where up to 10% of the output current is wasted as quiescent current, the quiescent current of the **UZ1086** flows into the load, increasing efficiency.

FEATURES

- * Low dropout voltage
- * Load regulation: 0.05% typical
- * Trimmed current limit
- * On-chip thermal limiting
- * Three-terminal adjustable or fixed 1.8V, 2.5V, 2.85V, 3.3V, 5V

ORDERING INFORMATION

Ordering Number		Package	Pin Assignment			Packing
Lead Free	Halogen-Free		1	2	3	
UZ1086L-xx-AA3-R	UZ1086G-xx-AA3-R	SOT-223	A/G	O	I	Tape Reel
UZ1086L-xx-TA3-T	UZ1086G-xx-TA3-T	TO-220	A/G	O	I	Tube
UZ1086L-xx-TN3-R	UZ1086G-xx-TN3-R	TO-252	A/G	O	I	Tape Reel
UZ1086L-xx-TN3-T	UZ1086G-xx-TN3-T	TO-252	A/G	O	I	Tube
UZ1086L-xx-TQ2-R	UZ1086G-xx-TQ2-R	TO-263	A/G	O	I	Tape Reel
UZ1086L-xx-TQ2-T	UZ1086G-xx-TQ2-T	TO-263	A/G	O	I	Tube
UZ1086L-xx-TQ3-R	UZ1086G-xx-TQ3-R	TO-263-3	A/G	O	I	Tape Reel
UZ1086L-xx-TQ3-T	UZ1086G-xx-TQ3-T	TO-263-3	A/G	O	I	Tube

Note: 1. xx: Output Voltage, refer to Marking Information.

2. A: ADJ (for adjustable regulator), G: GND (for fixed regulator)

<p>UZ1086L-xx-AA3-R</p> <p>(1)Packing Type (2)Package Type (3)Output Voltage Code (4)Lead Free</p>	<p>(1) R: Tape Reel, T: Tube (2) AA3: SOT-223, TA3: TO-220, TN3: TO-252, TQ2: TO-263, TQ3: TO-263-3 (3) xx: refer to Marking Information (4) G: Halogen Free, L: Lead Free</p>
--	--

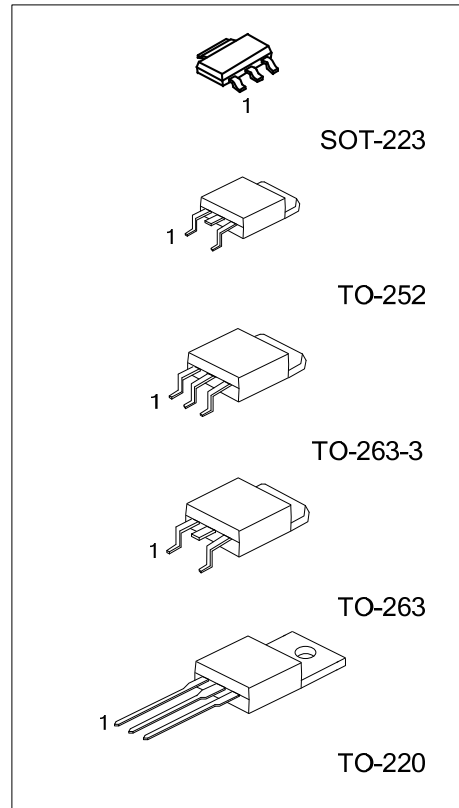

MARKING INFORMATION

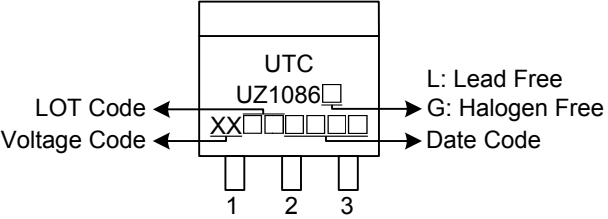
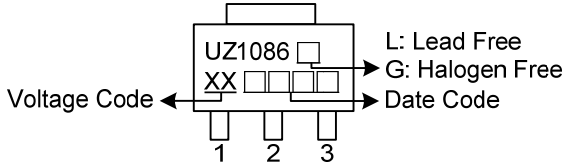
PACKAGE	VOLTAGE CODE	MARKING
TO-220 TO-252 TO-263 TO-263-3	18 :1.8V 25 :2.5V 2J :2.85V 33 :3.3V 50 :5.0V AD :ADJ	 <p>The diagram shows a TO-220 package with three pins labeled 1, 2, and 3. The top surface has a rectangular marking area containing the text 'UTC' and 'UZ1086'. Below this, there are two rows of characters: 'XX' followed by four small squares. Arrows point from these characters to labels: 'LOT Code' points to the first 'X', 'Voltage Code' points to the first square, 'L: Lead Free' points to the 'L' in 'UZ1086', 'G: Halogen Free' points to the 'G' in 'UZ1086', and 'Date Code' points to the first square in the second row.</p>
SOT-223		 <p>The diagram shows a SOT-223 package with three pins labeled 1, 2, and 3. The top surface has a rectangular marking area containing the text 'UZ1086'. Below this, there are two rows of characters: 'XX' followed by four small squares. Arrows point from these characters to labels: 'Voltage Code' points to the first 'X', 'L: Lead Free' points to the 'L' in 'UZ1086', 'G: Halogen Free' points to the 'G' in 'UZ1086', and 'Date Code' points to the first square in the second row.</p>

■ ABSOLUTE MAXIMUM RATINGS

PARAMETER	SYMBOL	RATINGS	UNIT
Input Voltage	V_{IN}	7.5	V
Junction Temperature	T_J	+125	°C
Operating Temperature	T_{OPR}	-40 ~ +85	°C
Storage Temperature	T_{STG}	-40 ~ +150	°C

Note: Absolute maximum ratings are those values beyond which the device could be permanently damaged. Absolute maximum ratings are stress ratings only and functional device operation is not implied.

■ THERMAL DATA

PARAMETER	SYMBOL	RATINGS	UNIT
Junction to Case	TO-252	12	°C/W
	TO-220	4	°C/W
	TO-263	4	°C/W
	SOT-223	15	°C/W

■ ELECTRICAL CHARACTERISTICS ($V_{IN} \leq 7V$, $T_J = 25^\circ C$, unless otherwise specified.)

PARAMETER	SYMBOL		TEST CONDITIONS	MIN.	TYP.	MAX.	UNIT				
Reference Voltage	V_{REF}	*	$1.5V \leq (V_{IN} - V_{OUT}) \leq 5.75V$ $10mA \leq I_{OUT} \leq 1A$	1.225	1.25	1.275	V				
Output Voltage	UZ1086-1.8	*	$10mA \leq I_{OUT} \leq 1A$				$3.3V \leq V_{IN} \leq 7V$	1.764	1.80	1.836	V
	UZ1086-2.5	*					$4V \leq V_{IN} \leq 7V$	2.450	2.50	2.550	V
	UZ1086-2.85	*					$4.35V \leq V_{IN} \leq 7V$	2.793	2.85	2.907	V
	UZ1086-3.3	*					$4.8V \leq V_{IN} \leq 7V$	3.234	3.30	3.366	V
	UZ1086-5.0	*					$6.5V \leq V_{IN} \leq 7V$	4.900	5.00	5.100	V
Line Regulation (Note1,2)	ΔV_{OUT}	*	$(V_{OUT} + 1.5V) \leq V_{IN} \leq 7V, I_{OUT} = 10mA$		0.005	0.2	%				
Load Regulation (Note1,2)	ΔV_{OUT}	*	$V_{IN} - V_{OUT} = 2V, 10mA \leq I_{OUT} \leq 1A$		0.05	0.5	%				
Dropout Voltage	V_D	*	$I_{OUT} = 1.5A$		1.30	1.50	V				
Current Limit	I_{LIMIT}	*	$V_{IN} - V_{OUT} = 2V$	1.6	2		A				
Adjust Pin Current	I_{ADJ}	*			35	120	μA				
Adjust Pin Current Change	ΔI_{ADJ}	*	$1.5V \leq (V_{IN} - V_{OUT}) \leq 5.75V,$ $10mA \leq I_{OUT} \leq 1A$		0.2	5	μA				
Minimum Load Current	$I_{O(MIN)}$	*	$1.5V \leq (V_{IN} - V_{OUT}) \leq 5.75V$			10	mA				
Quiescent Current	I_Q	*	$V_{IN} = V_{OUT} + 1.25V$		4	13	mA				
Ripple Rejection	RR		$f = 120Hz, C_{OUT} = 22\mu F, \text{Tantalum}$ $V_{IN} - V_{OUT} = 3V, I_{OUT} = 1.5A$	60	72		dB				
Thermal Regulation			$T_A = 25^\circ C, 30ms \text{ pulse}$		0.004	0.02	%/W				
Temperature Stability	ΔV_{OUT}	*			0.5		%				
Long-Term Stability	ΔV_{OUT}		$T_A = 125^\circ C, 1000hrs$		0.03	1.0	%				
RMS Output Noise	V_{OUT}		$T_A = 25^\circ C, 10Hz \leq f \leq 10kHz$		0.003		%				
Thermal shutdown			Junction Temperature		155		°C				
Thermal Shutdown Hysteresis					10		°C				

Note: 1. See thermal regulation specifications for changes in output voltage due to heating effects. Load and line regulation are measured at a constant junction temperature by low duty cycle pulse testing.

2. Line and load regulation are guaranteed up to the maximum power dissipation. Power dissipation is determined by input/output differential and the output current. Guaranteed maximum output power will not be available over the full input/output voltage range.

* stand for specifications which apply over the designed operating temperature range.

■ TYPICAL APPLICATION CIRCUIT

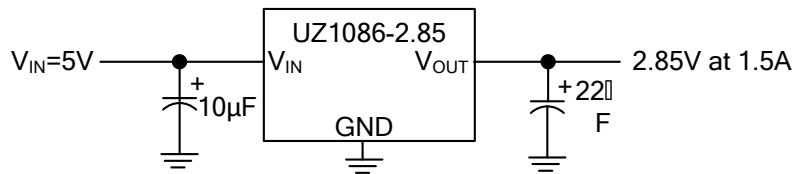
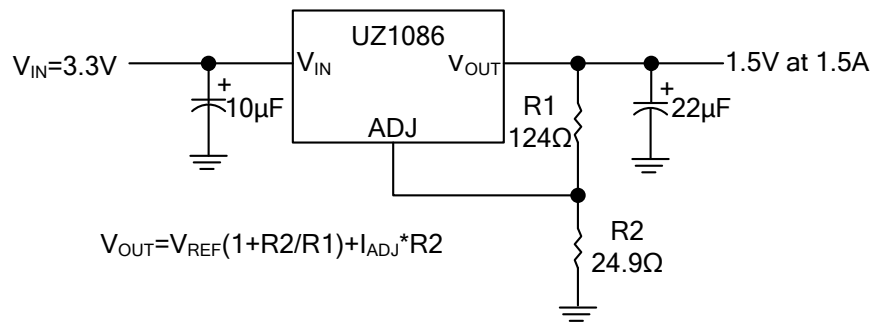

TYPICAL CHARACTERISTICS

Fig. 1 Dropout Voltage vs. Output Current

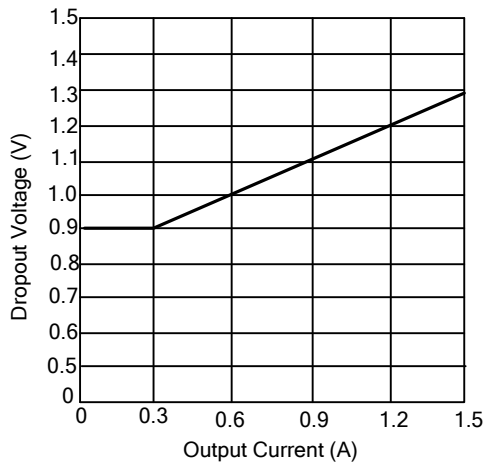

Fig. 2 Load Regulation vs. Temperature

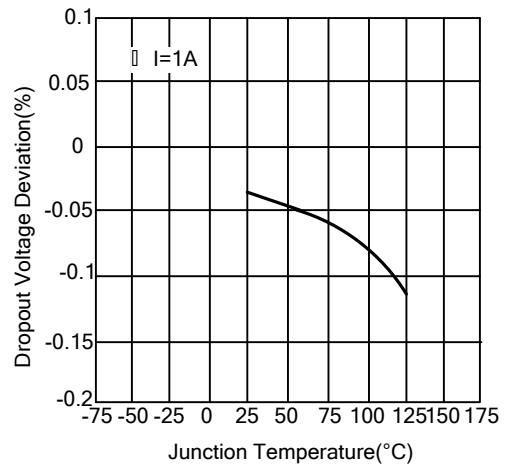

Fig. 3 Reference Voltage vs. Temperature

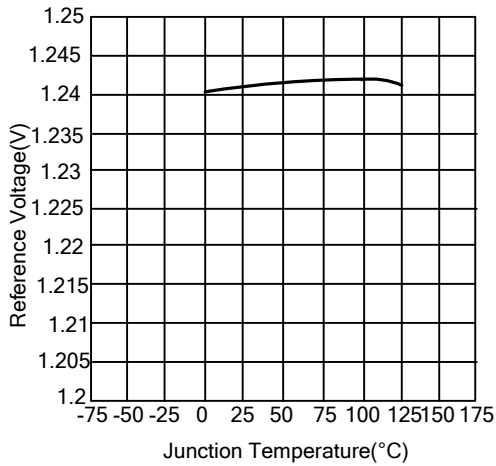

Fig. 4 Output Voltage vs. Temperature

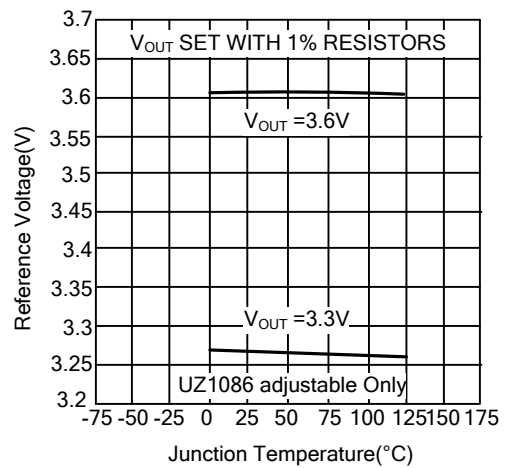

Fig. 5 Minimum Load Current vs. Temperature

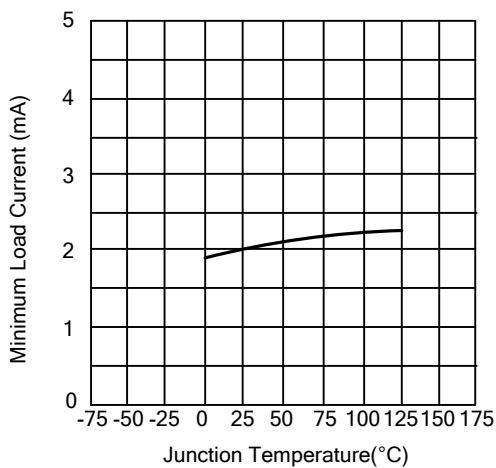
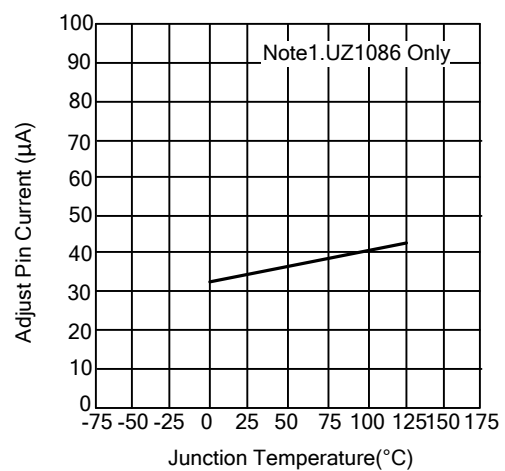
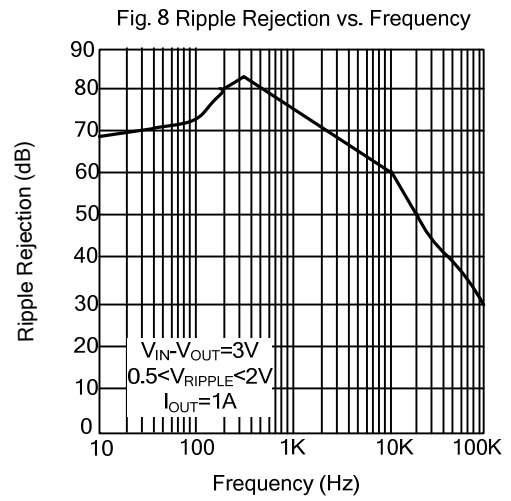
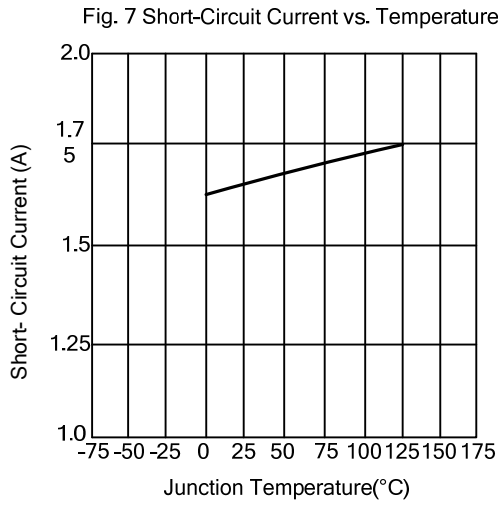

Fig. 6 Adjust Pin Current vs. Temperature



■ TYPICAL CHARACTERISTICS(Cont.)



UTC assumes no responsibility for equipment failures that result from using products at values that exceed, even momentarily, rated values (such as maximum ratings, operating condition ranges, or other parameters) listed in products specifications of any and all UTC products described or contained herein. UTC products are not designed for use in life support appliances, devices or systems where malfunction of these products can be reasonably expected to result in personal injury. Reproduction in whole or in part is prohibited without the prior written consent of the copyright owner. The information presented in this document does not form part of any quotation or contract, is believed to be accurate and reliable and may be changed without notice.