

MATERIALS

BODY	BRASS NICKEL PLATED
CONTACT	GOLD PLATED
INSULATOR	PTFE/PPE
COUPLING NUT	BRASS WHITE BRONZE PLATED

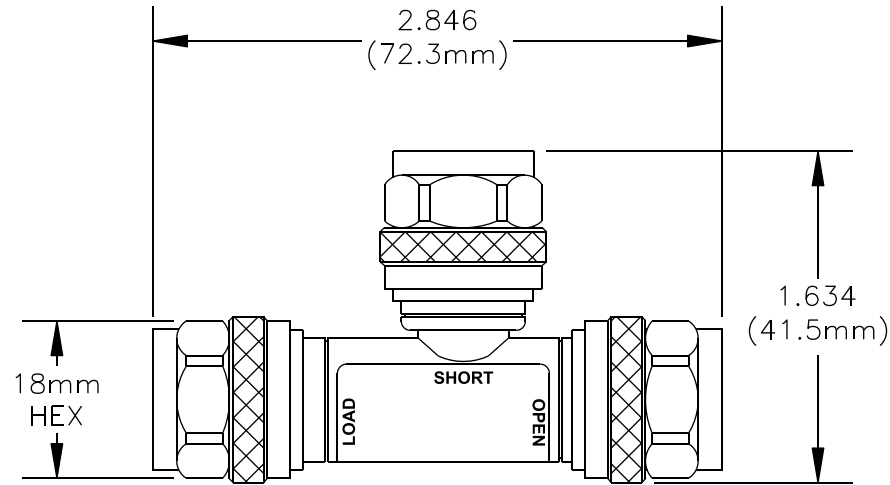

SPECIFICATIONS

Impedance	50Ω
Frequency	DC – 6 GHz
Open Return Loss	≤ 0.1 dB, DC – 6 GHz
Short Return Loss	≤ 0.1 dB, DC – 6 GHz
Load Return Loss	≤ 42 dB to 2.5 GHz ≤ 38 dB, 2.5 GHz – 6 GHz
Power Handling	1.0 W
Temp Range	–40°C to +85°C



PASTERNACK ENTERPRISES, INC.

P.O. BOX 16759, IRVINE, CA 92623
PHONE (949) 261-1920 FAX (949) 261-7451

WEB ADDRESS: www.pasternack.com
E-MAIL ADDRESS: sales@pasternack.com

COAXIAL & FIBER OPTICS

DWG TITLE

PE513

DES. N MALE 3-PORT FIELD CALIBRATION TOOL

REV. - **FSCM NO. 53919**

CAD FILE 100208

SCALE N/A

SIZE A 127

NOTES:

1. UNLESS OTHERWISE SPECIFIED ALL DIMENSIONS ARE NOMINAL.
2. ALL SPECIFICATIONS ARE SUBJECT TO CHANGE WITHOUT NOTICE AT ANY TIME.
3. DIMENSIONS ARE IN INCHES.