



TAI-SAW TECHNOLOGY CO., LTD.

No. 3, Industrial 2nd Rd., Ping-Chen Industrial District,
Taoyuan, 324, Taiwan, R.O.C.

TEL: 886-3-4690038 FAX: 886-3-4697532

E-mail: tstsales@mail.taisaw.com Web: www.taisaw.com

Approval Sheet For Product Specification

Issued Date: July, 31, 2007

Product Name: SAW Filter 770 MHz SMD 3.0X3.0 mm

TST Parts No.: TA0716A

Customer Parts No.: _____

Company: _____
Division: _____
Approved by : _____
Date: _____

Checked by: _____ Bob Chau

Approval by: _____ Francis Chen

Date: _____ 7, 31, 2007



TAI-SAW TECHNOLOGY CO., LTD.

No. 3, Industrial 2nd Rd., Ping-Chen Industrial District,
Taoyuan, 324, Taiwan, R.O.C.

TEL: 886-3-4690038 FAX: 886-3-4697532

E-mail: tstsales@mail.taisaw.com Web: www.taisaw.com

SAW Filter 770 MHz

MODEL NO.:TA0716A

REV. NO.:1

A. MAXIMUM RATING:

1. Input Power Level: 10 dBm
2. DC Voltage : 3V
3. Operating Temperature: -20°C to +70°C
4. Storage Temperature: -40°C to +85°C

RoHS Compliant
Lead free
Lead-free soldering

B. ELECTRICAL CHARACTERISTICS:

Item	Unit	Min.	Type.	Max.	Note
Center Frequency Fc	MHz	-	770	-	-
Insertion Loss (760 ~ 780 MHz) IL	dB	-	2.1	3	-
Amplitude Ripple (760 ~ 780 MHz)	dB	-	0.6	1.5	-
VSWR (760 ~ 780 MHz)		-	1.6	2	-
Attenuation (Reference level from 0 dB)					
560 ~ 730 MHz	dB	48	51.4	-	-
824 ~ 849 MHz	dB	36	44	-	-
849 ~ 970 MHz	dB	50	64	-	-

C. MEASUREMENT CIRCUIT:

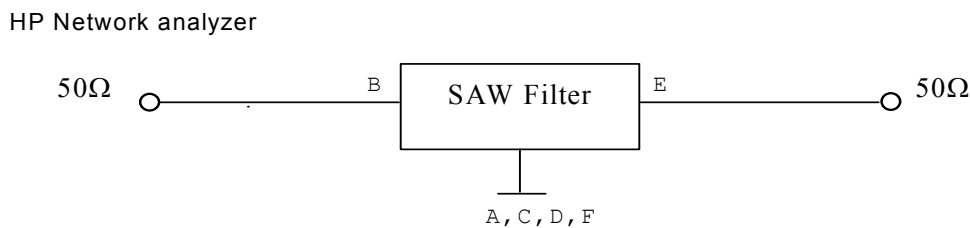

D.OUTLINE DRAWING:

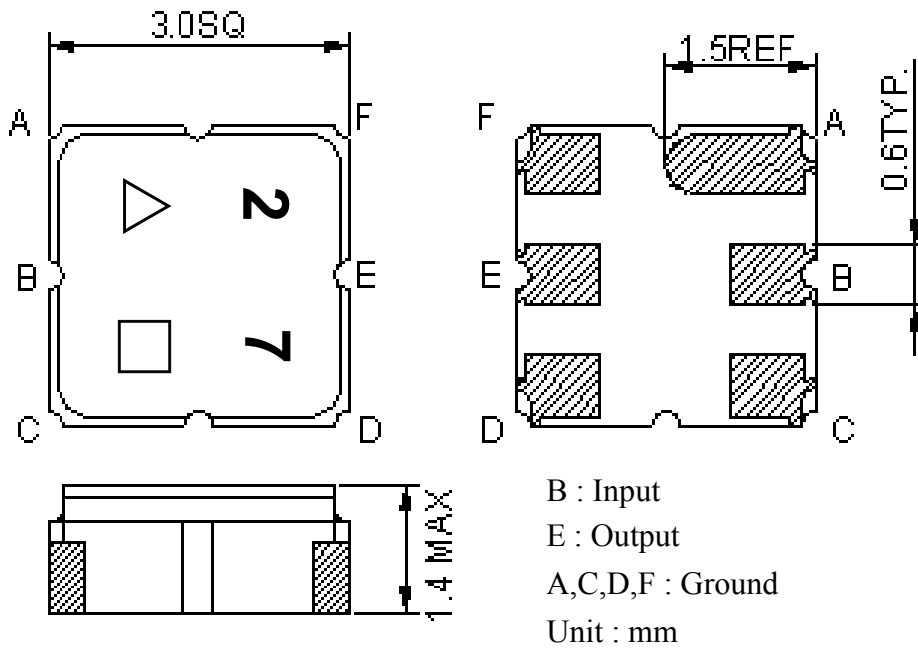

△ : Year Code (2006->6, ..., 2009->9)

□ : Date Code (Follow the table from planner each year)

E. PCB Footprint:

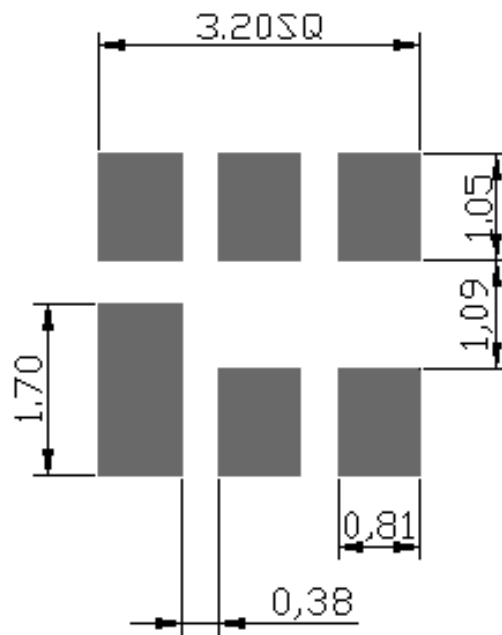

F. Frequency Characteristics :

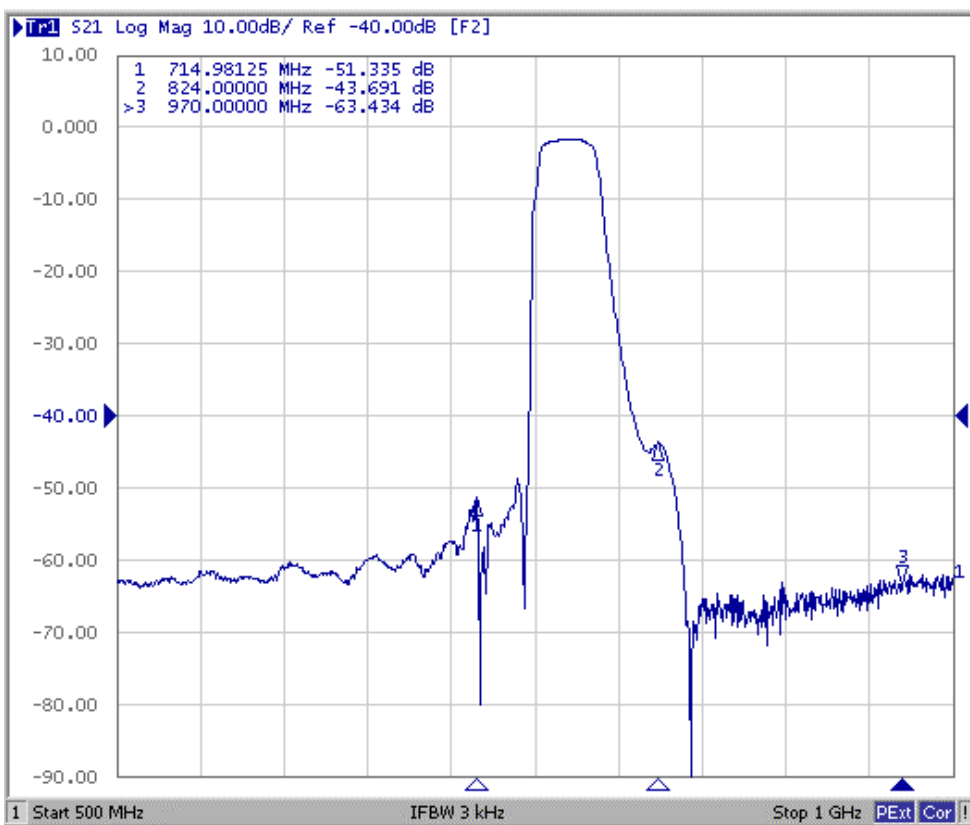
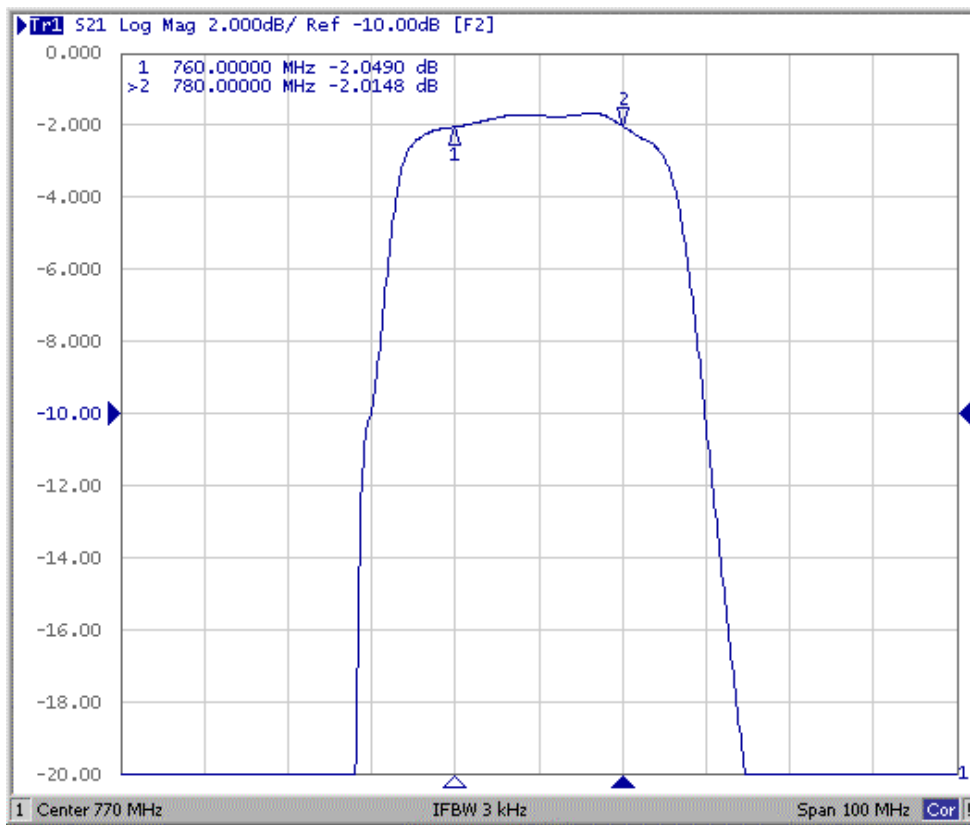

Reflection Functions :

S11

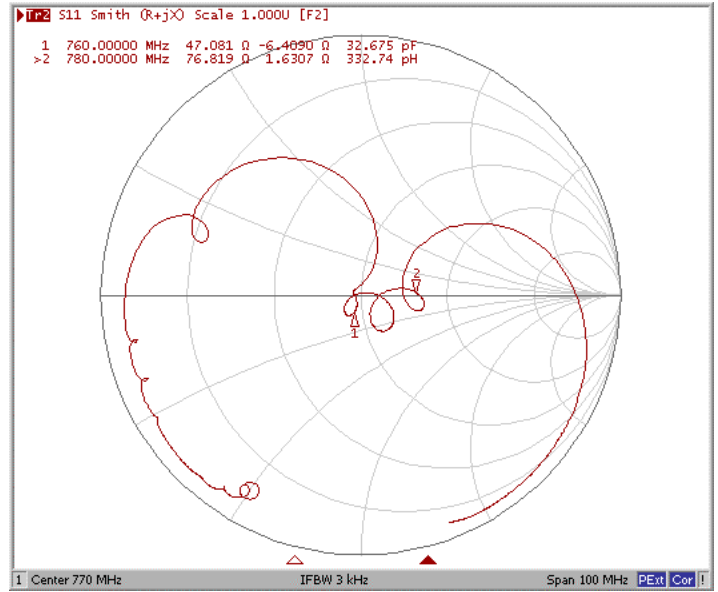
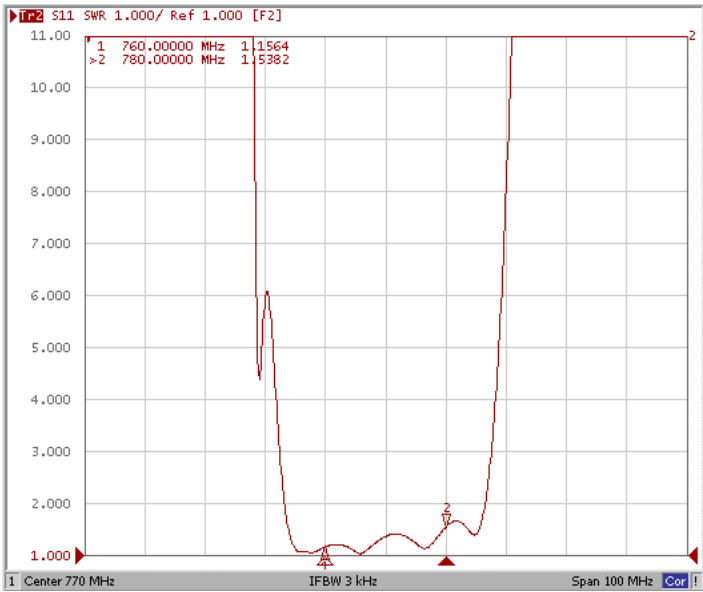

S22

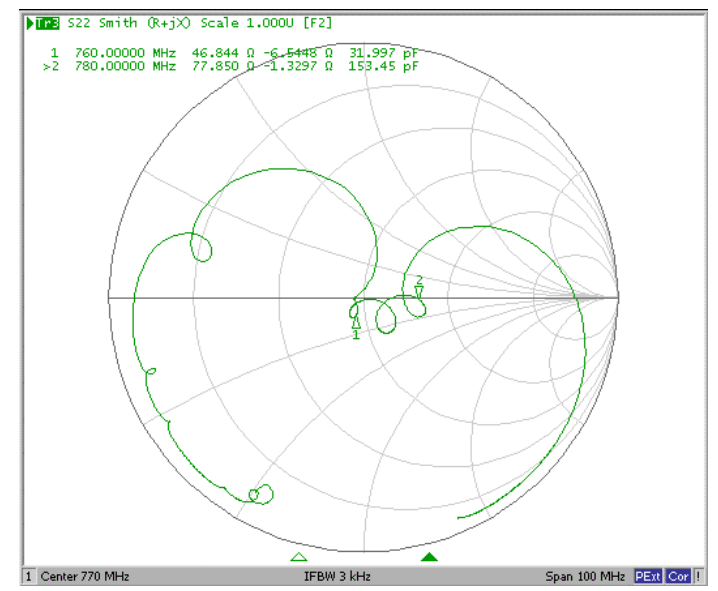
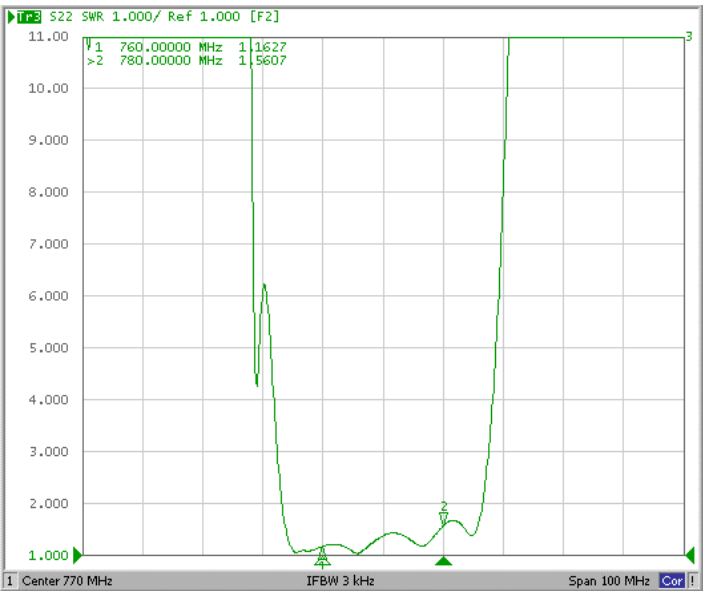

G. PACKING:

1. REEL DIMENSION

(Reel Count : 7"=1000 ; 13"=3000)

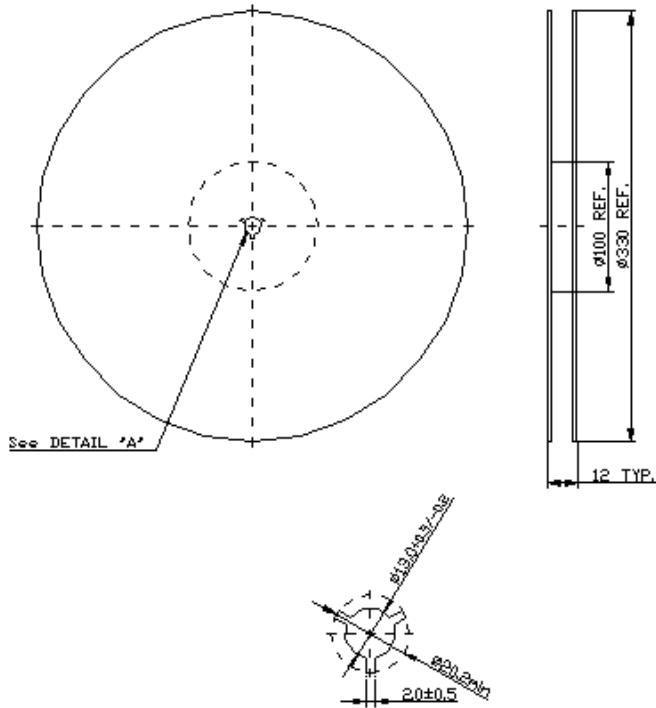

2. TAPE DIMENSION

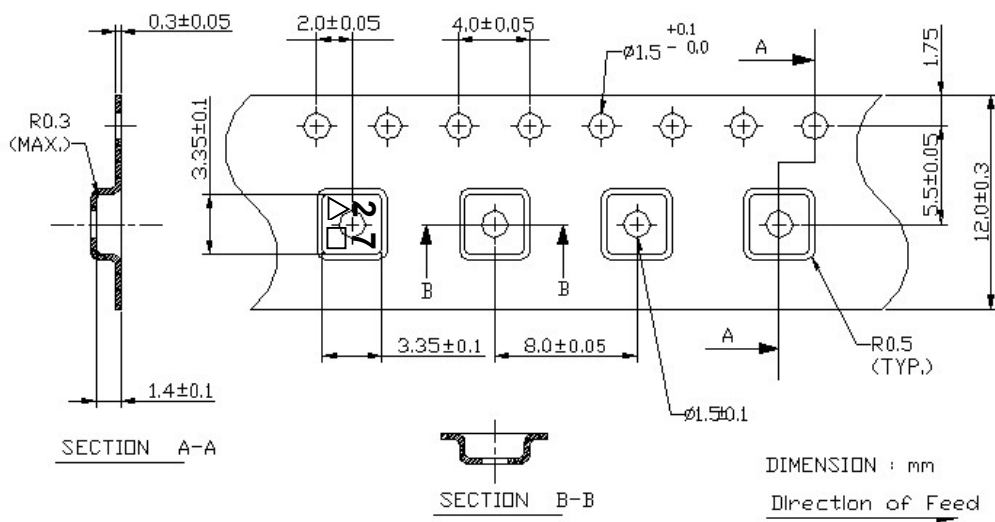

H. RECOMMENDED REFLOW PROFILE :

