

High dynamic range CMOS sensor

Data Brief

Features

- 1024 x 512 monochrome resolution sensor
- High dynamic pixel (5.6 μm x 5.6 μm)
- Parallel video data output interface (12 bit parallel interface)
- High speed serial link (CCP interface)
- I²C control interface
- SPI slave control interface
- UART control interface
- SPI master interface
- 3.3 V operation, 2.5 V for LVDS pads power supply
- On board 12 bit ADC
- Small physical size
- Ultra low power standby mode
- On chip PLL
- 34 fps maximum frame rate at full resolution
- On chip Anti Dark Sun correction
- On chip VFPN correction (CDS)
- On chip defect correction
- On chip microcontroller for system level flexibility

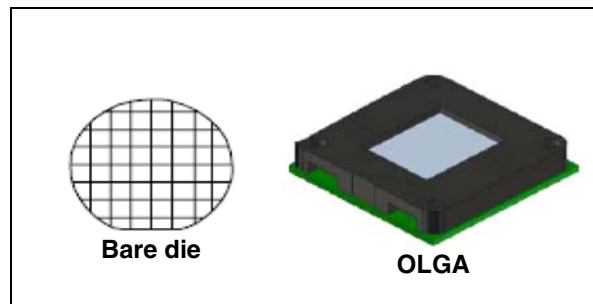

Applications

- Adaptive cruise control/stop and go
- Pedestrian detection and protection
- Headway/forward collision warning
- Pre-crash active safety
- Lane departure warning
- Lane keeping
- Night vision (NIR - Near InfraRed)
- Automatic high/low beam control
- Lane change assist
- Blind spot detection

Table 1. Device summary

Part number	Package	Packing
VL5510	Bare die	Tray
	OLGA	UNSAW DICE

Contents

1	Overview	3
	1.1 Technical specifications	3
	1.2 Description	4
2	Functional description	5
3	Revision history	7

1 Overview

1.1 Technical specifications

Table 2. Technical specifications

Pixel resolution	1024 x 512
Sensor technology	0.13 μm 4 layers metal
Pixel size	5.6 μm x 5.6 μm
Characteristic line	10 knee points
Analog gain	+24 dB (max)
Dynamic range (in scene)	120 dB
Dynamic range (overall)	140 dB
Signal to noise	TBD dB (@ 100 lux)
Minimum illumination	< TBD lux
Supply voltage	3.3 V ($\pm 10\%$) supply 2.5 V ($\pm 10\%$) LVDS I/O supply
Power consumption	< 150 mW @ 34 fps < 15 μW (standby mode)
Temperature range	-40 $^{\circ}\text{C}$ to + 125 $^{\circ}\text{C}$ Device functional @ 85 $^{\circ}\text{C}$ max
Shutter	Electrical rolling
Pixel fill factor	> 40 %
Remaining fixed pattern noise (FPN)	< 0.1 %
Temporal noise	< 0.1 %
Image lag	< 0.1 %
Defect pixels	To be specified
Package	Bare die/OLGA

1.2 Description

The VL5510 is a 0.13 μm CMOS digital camera featuring a high dynamic range (1024 x 512 resolution) for automotive applications. This complete camera module is ready to connect to the camera enabled baseband processor.

Video data is output from the VL5510 over a 12-bit parallel interface and a high speed serial link (8/10/12 bits raw data output format supported on the compact camera port (CCP) interface compatible with an SMIA (standard mobile imaging architecture) normative.

Control interface is an SPI (serial peripheral interface) or UART (universal asynchronous receiver transmitter) interface or I²C (Inter Integrated Circuit) interface.

Power supplies delivered to the sensor are:

- 3.3 V for the analog blocks,
- 3.3 V for the digital interface,
- 2.5 V for the high speed serial link interface,
- 1.2 V for the internal digital core (generated internally using a low drop output regulator).

The VL5510 is designed to operate in conjunction with an electronic central unit (ECU) that manages the device in the car.

An input clock is required in the range 6 MHz to 27.77 MHz.

The device contains an embedded video processor and delivers monochrome processed images at up to 34 frames per second. The video processor integrates a wide range of image enhancement functions, designed to ensure high image quality. These include:

- Antidark sun correction
- Dark calibration
- Vertical fix pattern correction
- Frame crop
- Defect pixel correction
- Test patterns generation
- Statistics generation (histogram)
- Sensor status data embedding (SCL, trailer)

2 Functional description

The block diagram of the VL5510 is shown in [Figure 1](#). VL5510 includes the following main blocks:

- Internal host (eWARP microcontroller): This is the internal host which is responsible for system operation sequencing and image data processing. It has the following features:
 - Safe system startup from hardware standby to software standby
 - System boot to drive it from software standby to streaming mode
 - System streaming soft stop
 - Device reinitialization to default mode (software reset)
 - High Dynamic mode setting (take in charge the management of the hardware knee point setting).
- ICB: Imager control block which contains all communication interfaces, transaction routings and resets and clock management
- IDP: Imager data pipeline which is responsible for real-time data processing at pixel clock rate. It implements a set of correction algorithms and dedicated block-IPs for data coding.
- CAB: Custom analog macro which contains the pixel array and all analog components that allow it to be driven.
- Data transmitters: Video data coders and transmitters, including serial and parallel interface.

Figure 1. VL5510 block diagram

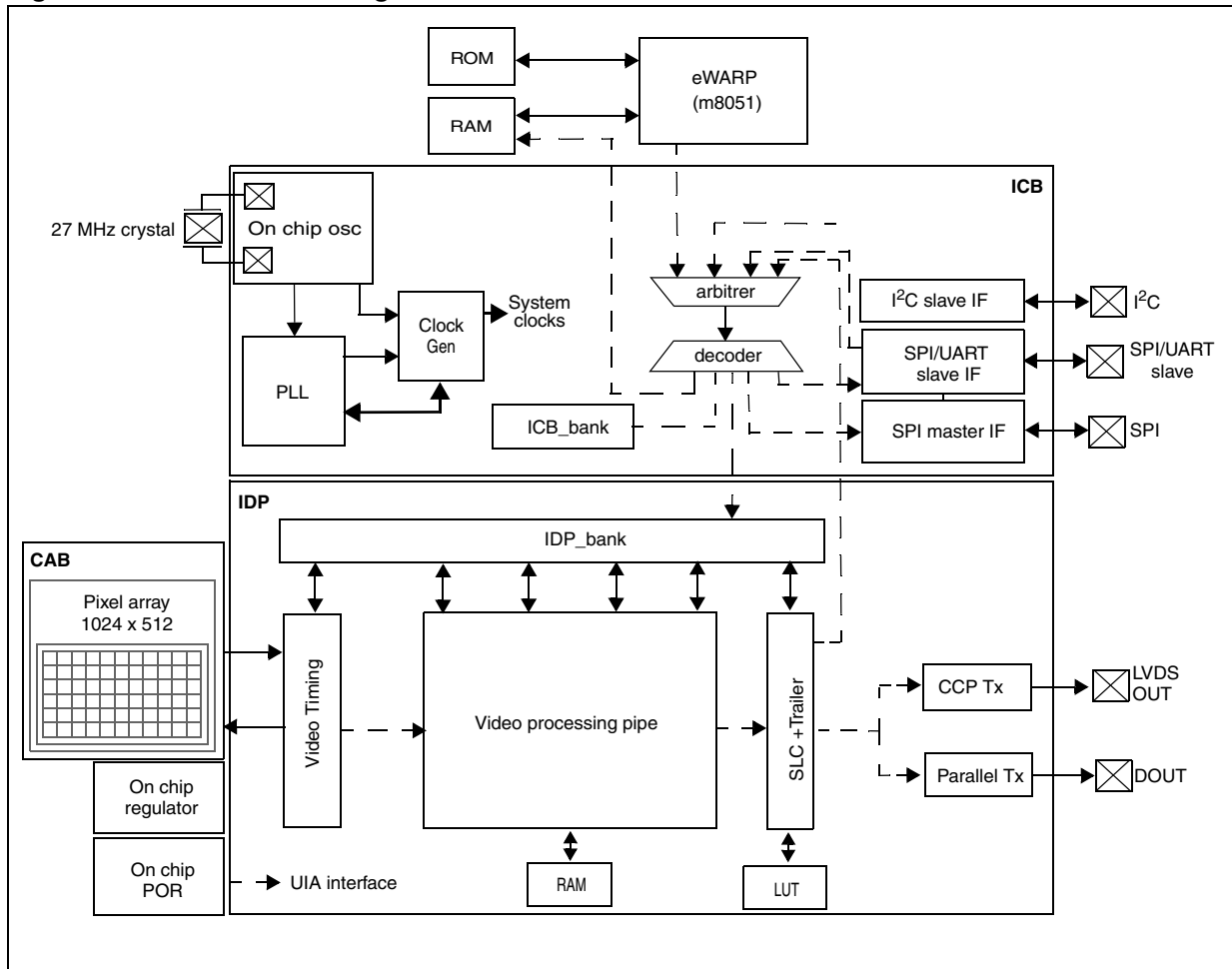

3 Revision history

Table 3. Document revision history

Date	Revision	Changes
19-Jun-2007	1	Initial release.
13-Oct-2008	2	Changed data in Table 2: Technical specifications Updated information in Section 1.2: Description Updated information in Section 2: Functional description

Please Read Carefully:

Information in this document is provided solely in connection with ST products. STMicroelectronics NV and its subsidiaries ("ST") reserve the right to make changes, corrections, modifications or improvements, to this document, and the products and services described herein at any time, without notice.

All ST products are sold pursuant to ST's terms and conditions of sale.

Purchasers are solely responsible for the choice, selection and use of the ST products and services described herein, and ST assumes no liability whatsoever relating to the choice, selection or use of the ST products and services described herein.

No license, express or implied, by estoppel or otherwise, to any intellectual property rights is granted under this document. If any part of this document refers to any third party products or services it shall not be deemed a license grant by ST for the use of such third party products or services, or any intellectual property contained therein or considered as a warranty covering the use in any manner whatsoever of such third party products or services or any intellectual property contained therein.

UNLESS OTHERWISE SET FORTH IN ST'S TERMS AND CONDITIONS OF SALE ST DISCLAIMS ANY EXPRESS OR IMPLIED WARRANTY WITH RESPECT TO THE USE AND/OR SALE OF ST PRODUCTS INCLUDING WITHOUT LIMITATION IMPLIED WARRANTIES OF MERCHANTABILITY, FITNESS FOR A PARTICULAR PURPOSE (AND THEIR EQUIVALENTS UNDER THE LAWS OF ANY JURISDICTION), OR INFRINGEMENT OF ANY PATENT, COPYRIGHT OR OTHER INTELLECTUAL PROPERTY RIGHT.

UNLESS EXPRESSLY APPROVED IN WRITING BY AN AUTHORIZED ST REPRESENTATIVE, ST PRODUCTS ARE NOT RECOMMENDED, AUTHORIZED OR WARRANTED FOR USE IN MILITARY, AIR CRAFT, SPACE, LIFE SAVING, OR LIFE SUSTAINING APPLICATIONS, NOR IN PRODUCTS OR SYSTEMS WHERE FAILURE OR MALFUNCTION MAY RESULT IN PERSONAL INJURY, DEATH, OR SEVERE PROPERTY OR ENVIRONMENTAL DAMAGE. ST PRODUCTS WHICH ARE NOT SPECIFIED AS "AUTOMOTIVE GRADE" MAY ONLY BE USED IN AUTOMOTIVE APPLICATIONS AT USER'S OWN RISK.

Resale of ST products with provisions different from the statements and/or technical features set forth in this document shall immediately void any warranty granted by ST for the ST product or service described herein and shall not create or extend in any manner whatsoever, any liability of ST.

ST and the ST logo are trademarks or registered trademarks of ST in various countries.

Information in this document supersedes and replaces all information previously supplied.

The ST logo is a registered trademark of STMicroelectronics. All other names are the property of their respective owners.

© 2008 STMicroelectronics - All rights reserved

STMicroelectronics group of companies

Australia - Belgium - Brazil - Canada - China - Czech Republic - Finland - France - Germany - Hong Kong - India - Israel - Italy - Japan - Malaysia - Malta - Morocco - Singapore - Spain - Sweden - Switzerland - United Kingdom - United States of America

www.st.com