Ballast Controller for Metal Halide Lamps

1. Functional Description of the AMG-LM302

The AMG-LM302 is a Ballast Controller IC for Metal Halide Lamps (HID, CDM, HQI...).

The AMG-LM302 integrates all functions necessary for control of Metal Halide lamps including power factor correction (PFC), ignition voltage generation and overdrive, current supply and power management. The ballast controller specifically supports high stability of color temperature.

2. Features

PFC

- PFC operates in current controlled transition mode (TM) with overvoltage protection
- Separate undervoltage lockout for PFC and HID part
- Zero current detection for TM operation
- Real multiplier for excellent THD
- High pulse current driver output for HV Power MOS
- Internal reference voltage

HID

- Current mode controlled buck converter
- Buck converter with Driver for external transistor
- Power drive mode for HV MOSFETS
- Safe ignition through burst oscillation
- 30kHz PWM in capture compare mode with maximum duty cycle of 50%
- Regulation of lamp power
- Slope compensation
- Open load and short-circuit detection
- Completely adjustable current and power ramp during lamp warm-up period
- Full bridge drive for acoustic control
- Automatic time control for all function
- Monitoring of lamp state

General

- Wide supply range of 14.5V to 35V
- Low power startup current
- Disable function to shut down the ballast and reduce power consumption
- Over temperature protection
- Short-circuit protected
- Ambient temperature range: -25°C to +125°C
- Package: TQFP48

3. Application

The AMG-LM302 is suitable for all applications where the light spectrum and color temperature of the sun, which is given by Metal Halide lamps, are needed. The AMG-LM302 controls the whole lamp ballast and thus not only provides for a low cost solution, but also one, which is high quality and easy to design.

Ballast Controller for Metal Halide Lamps

3.1. Example Application Drawing

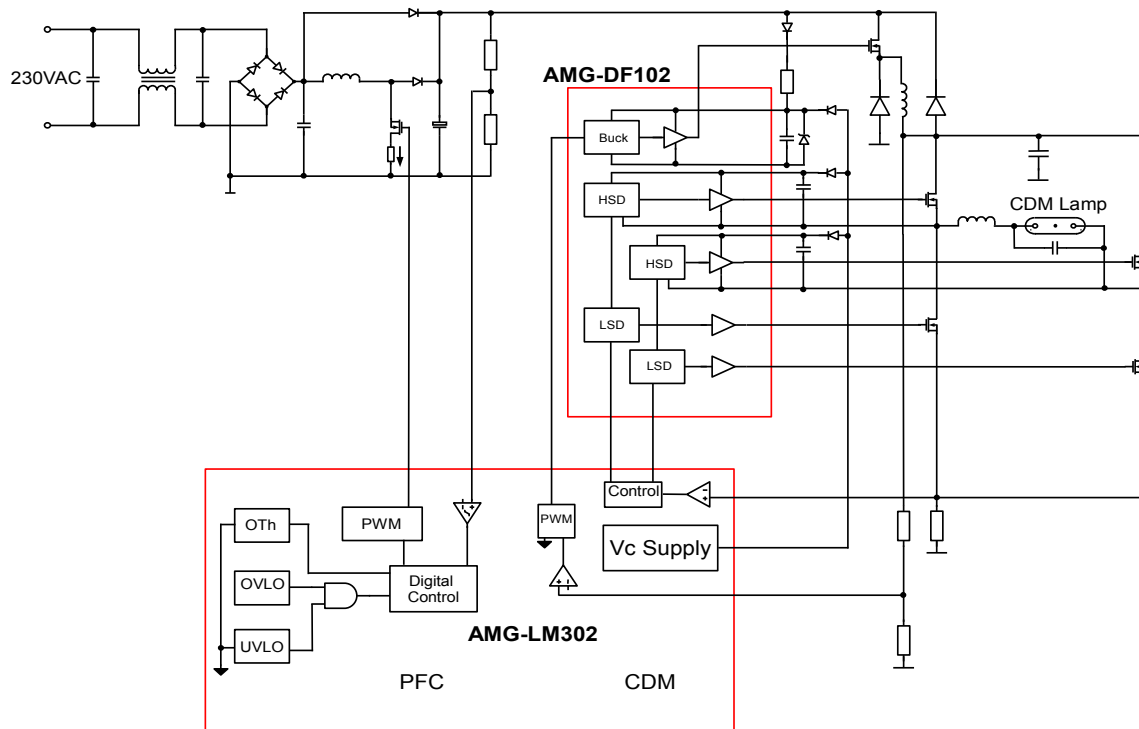

Figure 1: Simplified application drawing.

3.2. Application Notes

Please see AMG-AN-LM302.

Ballast Controller for Metal Halide Lamps**Table of Contents**

1.Functional Description of the AMG-LM302.....	1
2.Features.....	1
3.Application.....	1
3.1.Example Application Drawing.....	2
3.2.Application Notes.....	2
4.Block Diagram.....	4
5.Block Descriptions (optional).....	5
6.Pinning / Pad Coordinates.....	6
7.Pin description (optional).....	8
8.Absolute Maximum Ratings.....	8
9.Electrical Characteristics.....	10
9.1.Operational Range.....	10
9.2.DC Characteristics.....	10
9.3.AC Characteristics.....	14
10.Flow Chart	16
11.Timing Diagrams.....	17
12.Application.....	18
12.1.Example Application Circuit(s).....	18
12.2.Calculating PFC Parameters.....	18
12.3.Calculating HID Parameters.....	19
12.4.Application Notes.....	20
13.IC-Package.....	20
14.IC-Marking.....	20
15.Ordering Information.....	21
16.Notes and Cautions.....	21
16.1.ESD Protection.....	21
16.2.Storage conditions.....	21
17.Disclaimer.....	21
18.Contact Information.....	22

Ballast Controller for Metal Halide Lamps

4. Block Diagram

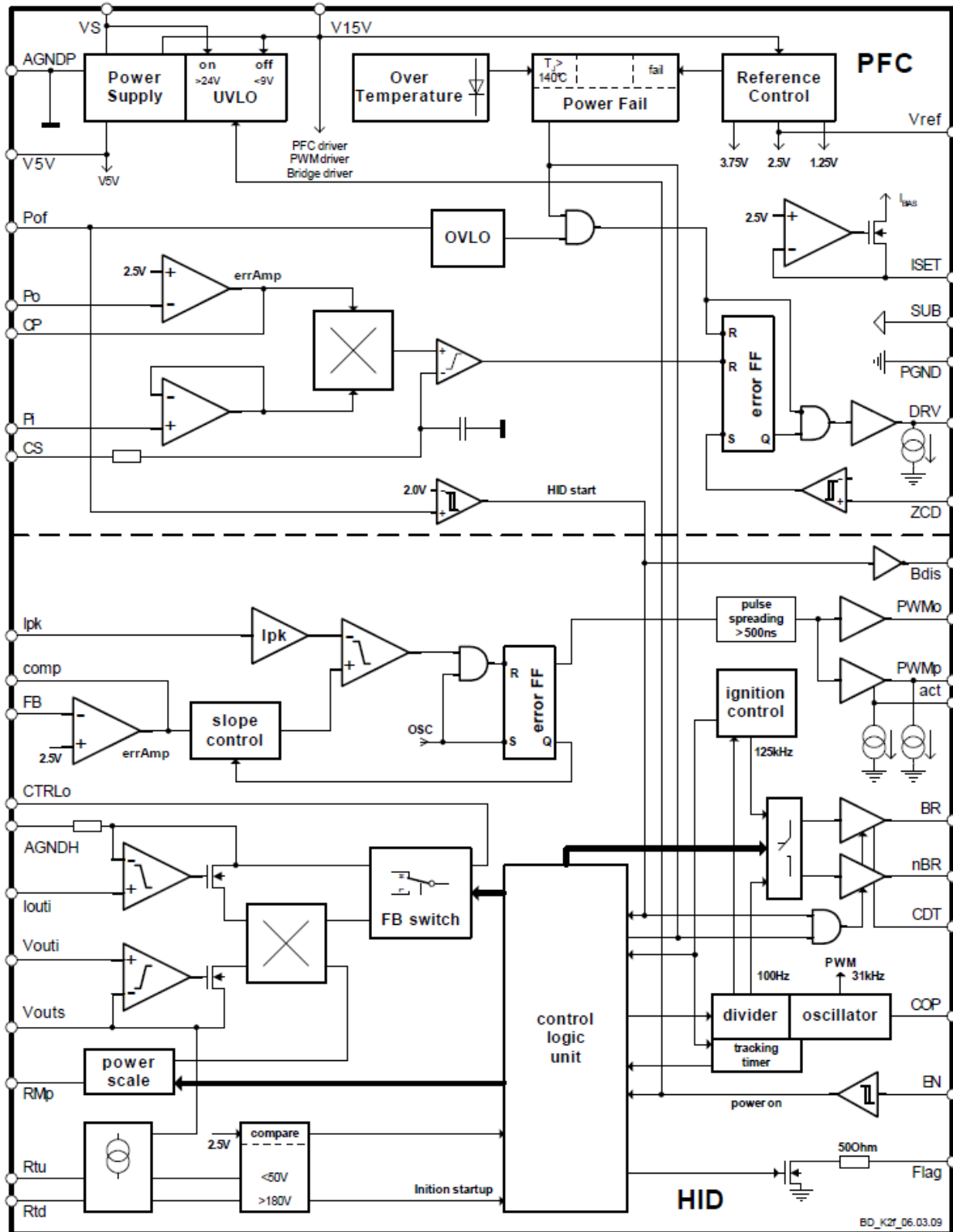

Ballast Controller for Metal Halide Lamps

5. Block Descriptions

The whole application for a metal halide lamp needs the following major function blocks:

- mains rectification
- PFC
- lamp power regulation
- lamp ignition control
- high voltage bridge
- bridge drivers

The mains rectification and the high voltage bridge are completely built using discrete components.

There are two basic options to do the bridge drivers, either discrete or integrated. Alpha recommends the use of a fully integrated full bridge gate driver AMG-DF102.

The AMG-LM302 does have the PFC, lamp power regulation, ignition control and other subfunctions integrated.

The PFC part of the AMG-LM302 is a standard power factor correction regulator.

The CDM part contains the power and ignition control of the lamp. For power control the lamp current I_{outi} and the lamp voltage V_{outi} get measured and then multiplied to receive the actual lamp power. The power is then outputted via the CTRL0 pin. It can be manipulated and filtered by external devices and will then get fed (as the actual value) into an error amplifier via the FB pin. The error amplifier uses an internal 2.5V reference voltage as the set value. The output of the error amplifier is fed into a current limiter stage and finally outputted via the PWM0 pin. The signal from the PWM0 pin eventually drives the buck converter, thus impacting the bridge voltage and in turn the lamp power.

A capacitor connected to the COP pin sets the frequency of the internal oscillator. The oscillator frequency eventually determines the switching frequency of the bridge. The oscillator frequency needs to be double the resonant frequency of the LC low pass filter for the CDM-lamp. The output BR drives a low and it's corresponding high side transistor. The output nBR is inverted to BR and drives the other low and high side transistors. A dead time is automatically inserted before the rising edges of BR and nBR so to avoid shoot through. This dead time can externally be influenced with a capacitor connected to the CDT pin. The switching frequency of the oscillator should not be high enough, to avoid audible noise from the plasma in the lamp. It should not be too high either, cause this will increase power consumption.

There is a control logic, which senses the state of the lamp. For ignition, it will generate a high

Ballast Controller for Metal Halide Lamps

switching frequency on the bridge. For burn state, it will generate a low switching frequency on the bridge.

The open drain output Flag indicates the current state of the application:

Flag is high impedance = standby, low power mode

Flag is low = start up phase

Flag is changing state between low and high impedance = lamp ignition phase

The Flag output maybe used to drive an LED (with ext. resistor) or as a status indication to other circuitry.

When the lamp is hot, the ignition phase can be very long (up to 30min.).

For the calculation of the various values of resistors and capacitors, please refer to section 11. Applications and/or application note AMG-AN-LM302.

Ballast Controller for Metal Halide Lamps

6. Pinning

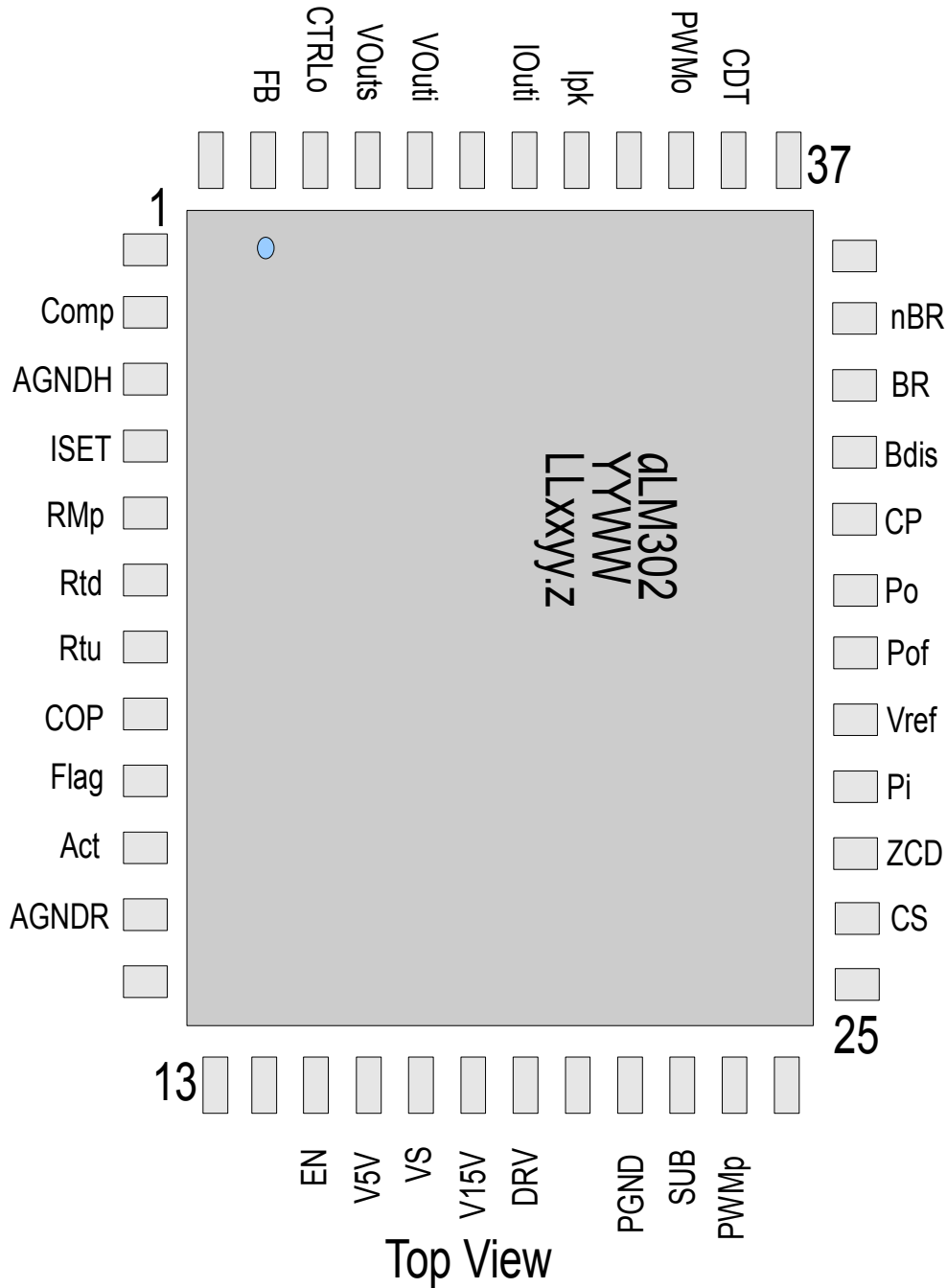

Ballast Controller for Metal Halide Lamps

PIN #	Symbol	Description
1	nc	
2	comp	Frequency compensation output of the CDM error amplifier
3	AGNDH	Ground connection for analog circuitry in the CDM part
4	ISET	Adjust bias current with 500kOhm to AGNDH
5	RMp	Adjust steady state lamp current with resistor to AGNDH
6	Rtd	Setting upper voltage threshold for lamp power in the steady-state mode (<180V) with a resistor to AGNDH
7	Rtu	Setting lower voltage threshold for lamp power in the steady-state mode (>50V) with a resistor to AGNDH
8	COP	A capacitor from COP to AGNDH together with ISET determines the PWM and bridge frequency
9	Flag	Indication of CDM-lamp state - Flag = high impedance => standby or low power mode - Flag = low => start up phase - Flag changes between high and low impedance => ignition phase
10	act	Connection with V5V activates the power MOS driver, connection with PGND or open deactivates the power MOS driver
11	AGNDR	Ground connection for analog circuitry in the PFC part
12	nc	
13	nc	
14	nc	
15	EN	A high level enables the IC and starts operation a low level puts the IC into standby (reduced power consumption)
16	V5V	Internally generated 5V power supply for analog and digital stages, may also feed external devices
17	VS	Main supply for the IC, input voltage range 14.5V to 35V
18	V15V	Internally generated 15V power supply for PFC and CDM drivers, may feed external devices
19	DRV	PFC power MOS Driver output
20	nc	
21	PGND	Driver Ground
22	SUB	Substrate, connect to PGND
23	PWMP	Additional power MOS driver supplied with V15V, activated when pin "act" is connected to V5V
24	nc	
25	nc	
26	CS	Current sense = peak current detection of PFC
27	ZCD	Zero current sense input for PFC inductor
28	Pi	Mains voltage phase sense input

Ballast Controller for Metal Halide Lamps

PIN #	Symbol	Description
29	Vref	2.5V internal Vref, may also be used for external circuitry, needs a C
30	Pof	PFC voltage control input
31	Po	PFC phase control input
32	CP	Compensation output for PFC regulation low pass filter (20Hz)
33	Bdis	Bdis=H: disables the full bridge for the lamp, all driver outputs = L
34	BR	Output to drive low and corresponding high side of the bridge
35	nBR	Inverted BR, drives other low and high side (dead time inserted automatically)
36	nc	
37	nc	
38	CDT	Capacitor (connected to AGNDH) sets dead time of the MOSFETS
39	PWMo	PWM output of the HV-driver for the buck power MOS
40	nc	
41	lpk	Current mode control input for PWM driver of CDM part limiting the peak driver current
42	louti	Monitors the lamp current with a sense resistor, lamp power is calculated using louti*Vouti
43	nc	
44	Vouti	Voltage divider input to sense the lamp voltage with respect to AGNDH (99:1)
45	Vouts	Resistor to convert V _{OUT} in to a related current
46	CTRLo	This control output generates the feedback for the error amplifier. Output depends on the operating mode (Lamp current or power)
47	FB	Feedback input (actual value) to the error amplifier 2.5V (set value) is the other input to the error amplifier
48	nc	

1)

7. Absolute Maximum Ratings

The Absolute Maximum Ratings may not be exceeded under any circumstances.

#	Symbol	Parameter	Min	Max	Unit
1	VS	Supply voltage	-0.3	37	V
2	V15V	Internal supply voltage	-0.3	18	V
3	V5V	Internal supply voltage	-0.3	6.2	V
4	lout_s	Power supply output current V15V, V5V	-5	0.01	mA
5	I _{DRV} ; I _{PWMP}	Driver peak current	-800	800	mA

Ballast Controller for Metal Halide Lamps

#	Symbol	Parameter	Min	Max	Unit
6	E _{DRV} ; E _{PWMP}	Driver peak energy		5	μJ
7	V _{inp_hv}	High voltage input EN	-0.3	V _S +0.3	V
8	V _{Flag_H}	Open drain high voltage	-0.3	V _S +0.3	V
9	I _{Flag_L}	Flag ON current	-1.0	5.0	mA
10	V _{inp_lv}	Low voltage input Pi, CS, Po, Pof, Ipk, COP, act, CDT, Rtu, Rtd, CM3, Rmp, FB, Iouti, Vouti, Vouts	-0.3	V _{5V} +0.3	V
11	I _{inp_zcd}	Input current ZCD	-10	10	mA
12	I _{outp_hv}	High voltage control output BR, nBR, PWMo, Bdis	-1.0	1.0	mA
13	I _{outp_lv}	Low voltage control output CP, comp, CTRLo, Vref	-5.0	5.0	mA
14	V _{ISET}	Bias adjust input voltage	-0.3	V _{5V} +0.3	V
15	I _{ISET}	Bias adjust input current	-200	1	μA
16	AGNDH AGNDP PGND	Ground voltages related to substrate (SUB)	-0.3	0.3	V
17	T _{stg}	Storage temperature	-65	150	°C
18	R _{thja}	Thermal resistance junction to ambient		tbd	K/W
19	V _{ESD}	ESD rating		1	kV

Ballast Controller for Metal Halide Lamps

8. Electrical Characteristics

8.1. Operational Range

#	Symbol	Parameter	Min	Max	Unit
1	VS	Supply voltage	14.5	35	V
2	T _a	Ambient temperature range	-25	85	°C

Note:

8.2. DC Characteristics

DC characteristics contain the spread of values guarantee within the specified supply voltage and temperature range and the technology process parameter range unless otherwise specified.

R_{ISET}=500kΩ±0.5%; COP=180pF±0.5%; R_{Po}=R_{PC}=10kΩ±0.5%; R_{Fc}=R_{FB}=10kΩ±0.5%; V_{EN}=VS;
V_{act}=0V; R_{VOUTA}=R_{VOUTB}=R_{VOUTC}=10kΩ±0.5%; R_{td}=69.5kΩ; R_{tu}=250kΩ

Typical characteristics represent the medium of production at VS=27V; Ta=25°C

#	Symbol	Parameter	Conditions	Min	Typ	Max	Unit
SECTION: General (G)							
SUBSECTION: Supply							
1	I _{VS}	Operating supply current			tbd	tbd	mA
2	I _{VS_STBY}	Standby current	V _{EN} =0V or VS=7V			1.0	mA
3	V _{V15V}	Internal DC voltage 15V	VS=16.5V to 35V; I _{V15V} =-5mA	-10%	15	+10%	V
4	V _{V15V_drop}	VS-V _{V15V}	VS=8V ... 16.5V; I _{V15V} =-5mA			1.5	V
5	V _{V5V}	Internal DC voltage 5V		-10%	5	+10%	V
SUBSECTION: Over temperature							
6	T _{JOT}	Thermal shutdown junction temperature		130			°C
SUBSECTION: Under voltage lockout (UVLO)							
7	V _{VS_ON}	VS turn on threshold			24		V
8	V _{V15V_OFF}	V15V turn off threshold		8.5		10.5	V
SUBSECTION: Enable (EN)							
9	V _{EN_H}	IC enable		3.0			V
10	V _{EN_L}	IC disable				1.5	V
11	V _{EN_hys}	Switch hysteresis			500		mV
12	I _{EN}	EN input current	V _{EN} =0V	-15	-5		μA

Ballast Controller for Metal Halide Lamps

#	Symbol	Parameter	Conditions	Min	Typ	Max	Unit
13	I_{EN}	EN input current	$V_{EN}=V_S$	-1		1	μA
SUBSECTION: Lamp monitoring							
14	V_{Flag_L}	Flag low output voltage	$I_{Flag}=5mA$		0.5	0.8	V
15	I_{Flag_H}	Flag high leakage current	$V_{Flag}=V_S$	-5		5	μA
SUBSECTION: Reference voltage							
16	V_{ref}	Reference for PFC and HID		-3%	2.5	+3%	V
17	V_{ref+I}	Reference load capability	$I_{ref}=+5mA$		2.5	2.7	V
18	V_{ref-I}		$I_{ref}=-5mA$	2.3	2.5		V
19	V_{FB}	Reference for lamp voltage regulation: 2.5V	tbd	tbd	2.5	tbd	V
20	V_{ISET}	Biasing reference Voltage	tbd		2.5		V
SECTION: Power factor correction (PFC)							
SUBSECTION: Over voltage lockout (OVLO)							
21	V_{Pof_OVLO}	OVLO threshold			2.5		V
22	$V_{OVLO-hys}$	OVLO hysteresis			200		mV
SUBSECTION: HID enable (Bdis)							
23	V_{Pof_Bdis}	HID and Bridge enable threshold			2.0		V
24	$V_{Bdis-hys}$	HID and Bridge enable hysteresis			800		mV
25	V_{Bdis_H}	Output high voltage, bridge disabled	$I_{Bdis}=-2mA$	V15V -1.5			V
26	V_{Bdis_L}	Output low voltage, bridge enabled	$I_{Bdis}=2mA$			1.5	V
27	V_{Pof_Bdis}	HID and Bridge enable threshold			2.0		V
SUBSECTION: PFC multiplier							
28	V_{Pi}	Linear input voltage		3			V
29	M_G	Multiplier gain	$V_{Pi}=0.5V; \Delta V_{CP}=3V$		1.07		V^{-1}
30	M_R	Multiplier ratio $\Delta V_{CS} / \Delta V_{Pi} @ R_{pk_PFC}=10\Omega$	$\Delta V_{Pi}=0V \dots 0.5V;$ $V_{CP}=4.7V$ $\Delta V_{Pi}=0V \dots 1.0V;$ $V_{CP}=2.5V$		3.2		A/V
					1.6		A/V
SUBSECTION: PFC current sense							
31	V_{CS}	Upper sense clamp reference	$V_{CP}=4.7, V_{Pi}=1.0V$		1.75		V
32	I_{CS}	Input bias current	$V_{CS}=1V$	-1		1	μA
33	V_{CS_offs}	(DC) sense offset voltage				10	mV
34	t_{trans}	Transition time to DRV	$V_{CP}=4.7V, V_{Pi}=1.0V,$ $C_{DRV}=2.2nF$		250		ns
SUBSECTION: PFC error amplifier							
35	V_{Po}	Feedback input threshold			2.5		V

Ballast Controller for Metal Halide Lamps

#	Symbol	Parameter	Conditions	Min	Typ	Max	Unit
36	I_{Po}	Input bias current		-1		1	μA
37	A_V	Voltage gain	Open loop	60			dB
38	I_{CP_L}	Pos. current capability	$V_{CP}=2.5V$; $V_{Po}=3.25V$		3		mA
39	I_{CP_H}	Neg. current capability	$V_{CP}=2.5V$; $V_{Po}=1.75V$		-2		mA
40	V_{CP_H}	Upper output voltage limit	$I_{CP}=-0.5mA$	$V_{5V}-1.0$			V
41	V_{CP_L}	Lower output voltage limit	$I_{CP}=0.5mA$			1.0	V
SUBSECTION: Zero current detector (ZCD)							
42	V_{ZCD_CLH}	Upper clamp voltage	$I_{ZCD}=3mA$	3.2		4.5	V
43	V_{ZCD_CLL}	Lower clamp voltage	$I_{ZCD}=-3mA$	0.5		1.7	V
44	V_{ZCD_th}	ZCD threshold			2.5		V
45	I_{ZCD_C}	Pos. current capability		7			mA
46	I_{ZCD_C}	Neg. current capability				-10	mA
SUBSECTION: PFC driver							
47	V_{DRV_H}	Driver output high drop voltage related to V15V	$I_{DRV}=-20mA$			0.5	V
48	V_{DRV_H}	Driver output high drop voltage related to V15V	$I_{DRV}=-200mA$			2.0	V
49	V_{DRV_L}	Driver output low voltage	$I_{DRV}=20mA$			0.3	V
50	V_{DRV_L}	Driver output low voltage	$I_{DRV}=200mA$			1.5	V
51	I_{DRV_pk}	Driver peak current	2.2nF from DRV to PGND	400			mA
51	I_{DRV_dis}	Disable driver current	$V_{EN}=0V$ or $V_S=7V$; $V_{DRV}=1V$	5			mA
SECTION: HID controller (HID)							
SUBSECTION: Lamp voltage V/I convert							
52	V_{outi_OV}	Overvoltage threshold			3.45		V
53	V_{outi_bst}	Ignition try threshold (burst)			2.9		V
54	V_{outi_ign}	Ignition OK threshold			1.8		V
55	V_{outi_bu}	Upper break voltage			1.8		V
56	V_{outi_bd}	Lower break voltage			0.5		V
57	I_{VOUTi}	Input current		-1		1	μA
SUBSECTION: Lamp current V/I convert							
58	V_{Iouti}	Constant regulation			625		mV
59	I_{Iouti}	Iouti input current		-1		1	μA
SUBSECTION: Oscillator							
60	I_{COP_up}	Pull_up current	$V_{COP}=1V$		-70		μA

Ballast Controller for Metal Halide Lamps

#	Symbol	Parameter	Conditions	Min	Typ	Max	Unit
61	I_{COP_down}	Pull_down current	$V_{COP}=4V$		105		μA
62	V_{COP_thH}	Sawtooth upper threshold			3.33		V
63	V_{COP_thL}	Sawtooth lower threshold			1.67		V
SUBSECTION: HID error amplifier							
64	V_{FB}	Feedback voltage	closed loop		2.5		V
65	I_{FB}	FB input current		-1		1	μA
67	V_{comp}	comp output voltage	$I_{comp}=-2mA$; closed loop	2.0			V
68	V_{comp}	comp output voltage	$I_{comp}=3mA$; closed loop			3.0	V
69	V_{comp_H}	comp high output voltage	$I_{comp}=-0.5mA$; $V_{FB}=2V$	V5V- 1.0			V
70	V_{comp_L}	comp low output voltage	$I_{comp}=0.5mA$; $V_{FB}=3V$			1.0	V
SUBSECTION: Pulse width modulator (PWMo)							
71	DC_{max}	Maximum duty cycle			50		%
72	DC_{min}	Minimum duty cycle		1.5	2.3	5	%
73	V_{ipk_max}	Maximum I_{PK} voltage			1.25		V
74	V_{ipk_OC}	Over current I_{PK} voltage			2.5		V
75	V_{PWMo_H}	Output high voltage	$I_{PWMo}=-2mA$	V15V -1.5			V
76	V_{PWMo_L}	Output low voltage	$I_{PWMo}=2mA$			1.5	V
SUBSECTION: HID driver (PWMp)							
77	V_{PWMp_H}	Driver output high drop voltage related to V15V	$I_{PWMp}=-20mA$; $V_{act}=V5V$			0.5	V
78	V_{PWMp_H}	Driver output high drop voltage related to V15V	$I_{PWMp}=-200mA$; $V_{act}=V5V$			2.0	V
79	V_{PWMp_L}	Driver output low voltage	$I_{PWMp}=20mA$; $V_{act}=V5V$			0.3	V
80	V_{PWMp_L}	Driver output low voltage	$I_{PWMp}=200mA$; $V_{act}=V5V$			1.5	V
81	I_{PWMp_pk}	Driver peak current	2.2nF from PWMp to PGND; $V_{act}=V5V$	400			mA
82	I_{PWMp_dis}	Disable driver current	$V_{EN}=0V$ or $V_S=7V$; $V_{PWMp}=1V$	5			mA
83	V_{act_H}	PWMp driver activated		3.5			V
84	V_{act_L}	PWMp driver deactivated				1.5	V
85	I_{act}	pull down current	$V_{act}=5V$		10		μA
SUBSECTION: Acoustic bridge driver							
86	V_{BR_H}	Output high voltage	$I_{BR}=-2mA$	V15V -1.5			V
87	V_{BR_L}	Output low voltage	$I_{BR}=2mA$			1.5	V
88	V_{nBR_H}	Output high voltage	$I_{nBR}=-2mA$	V5V- 1.5			V

Ballast Controller for Metal Halide Lamps

#	Symbol	Parameter	Conditions	Min	Typ	Max	Unit
89	V_{nBR_L}	Output low voltage	$I_{nBR}=2mA$			1.5	V
SUBSECTION: Power scale							
90	V_{RMp}	Reference voltage for power scale resistor			2.5		V
SUBSECTION: Adjustable voltage threshold							
91	V_{Rtd}	Upper reference voltage for adjustable monitor resistor			2.5		V
92	V_{Rtu}	Lower reference voltage for adjustable monitor resistor			2.5		V

8.3. AC Characteristics

AC characteristics contain the spread of values guarantee within the specified supply voltage and temperature range and the technology process parameter range unless otherwise specified.

$R_{ISET}=500k\Omega\pm 0.5\%$; $COP=180pF\pm 0.5\%$; $R_{Po}=R_{PC}=10k\Omega\pm 0.5\%$; $R_{Fc}=R_{FB}=10k\Omega\pm 0.5\%$; $V_{EN}=VS$;
 $V_{act}=0V$; $R_{VOUTA}=R_{VOUTB}=R_{VOUTC}=10k\Omega\pm 0.5\%$; $Rtd=69.5k\Omega$; $Rtu=250k\Omega$

Typical characteristics represent the medium of production at $VS=27V$; $Ta=25^{\circ}C$

#	Sym bol	Parameter	Conditions	Min	Typ	Max	Uni t
1	tr_{DRV}	PFC driver output rise time	$C_{DRV}=2.2nF$		50		ns
2	tf_{DRV}	PFC driver output fall time	$C_{DRV}=2.2nF$		50		ns
3	F_{DRV}	PFC frequency range over one mains period	20	20		120	kHz
4	F_{OSC}	Oscillator frequency	$COP=100pF$		240		kHz
5	tr_{PWMo}	PWM output rise time	$C_{PWMo}=100pF$		100		ns
6	tf_{PWMo}	PWM output fall time	$C_{PWMo}=100pF$		100		ns
7	tr_{PwMp}	PWM power output rise time	$C_{DRV}=2.2nF$		50		ns
8	tf_{PwMp}	PWM power output fall time	$C_{BR}=100pF$ $C_{DRV}=2.2nF$		50		ns
9	F_{PWMo}	PWM switch frequency	$C_{BR}=100pF$ $C_{DRV}=2.2nF$		$\frac{F_{OSC}}{8}$		kHz
10	F_{BR_IGN}	Ignition resonance frequency	$C_{BR}=100pF$ $C_{DRV}=2.2nF$		$\frac{F_{OSC}}{2}$		kHz
11	tr_{BR}	Bridge driver output rise time	$C_{BR}=100pF$ $C_{DRV}=2.2nF$		100		ns
12	tf_{BR}	Bridge driver output fall time	$C_{BR}=100pF$		100		ns
13	F_{BR_A}	Bridge acoustic switch frequency			$\frac{F_{OSC}}{2^{11}}$		Hz
14	t_{t_on}	Ignition burst enable time					s

Ballast Controller for Metal Halide Lamps

#	Sym bol	Parameter	Conditions	Min	Typ	Max	Uni t
15	t_{it_off}	Ignition burst disable time			$\frac{2^{23}}{F_{osc}}$		s
16	N_{ip}	Number of ignition pulses for one burst			$\frac{2^{23}}{F_{osc}}$		
17	t_{ib}	Ignition burst repeat rate			10		s
18	t_{TI}	Total ignition trial time			$\frac{2^{10}}{F_{osc}}$		s
19	t_{btM}	Lamp voltage monitor block time after ignition (tracking timer)			$\frac{17 * 2^{24}}{F_{osc}}$		s

Ballast Controller for Metal Halide Lamps

9. Flow Chart

Working Mode

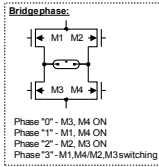

Function Flow Chart CDM

Description

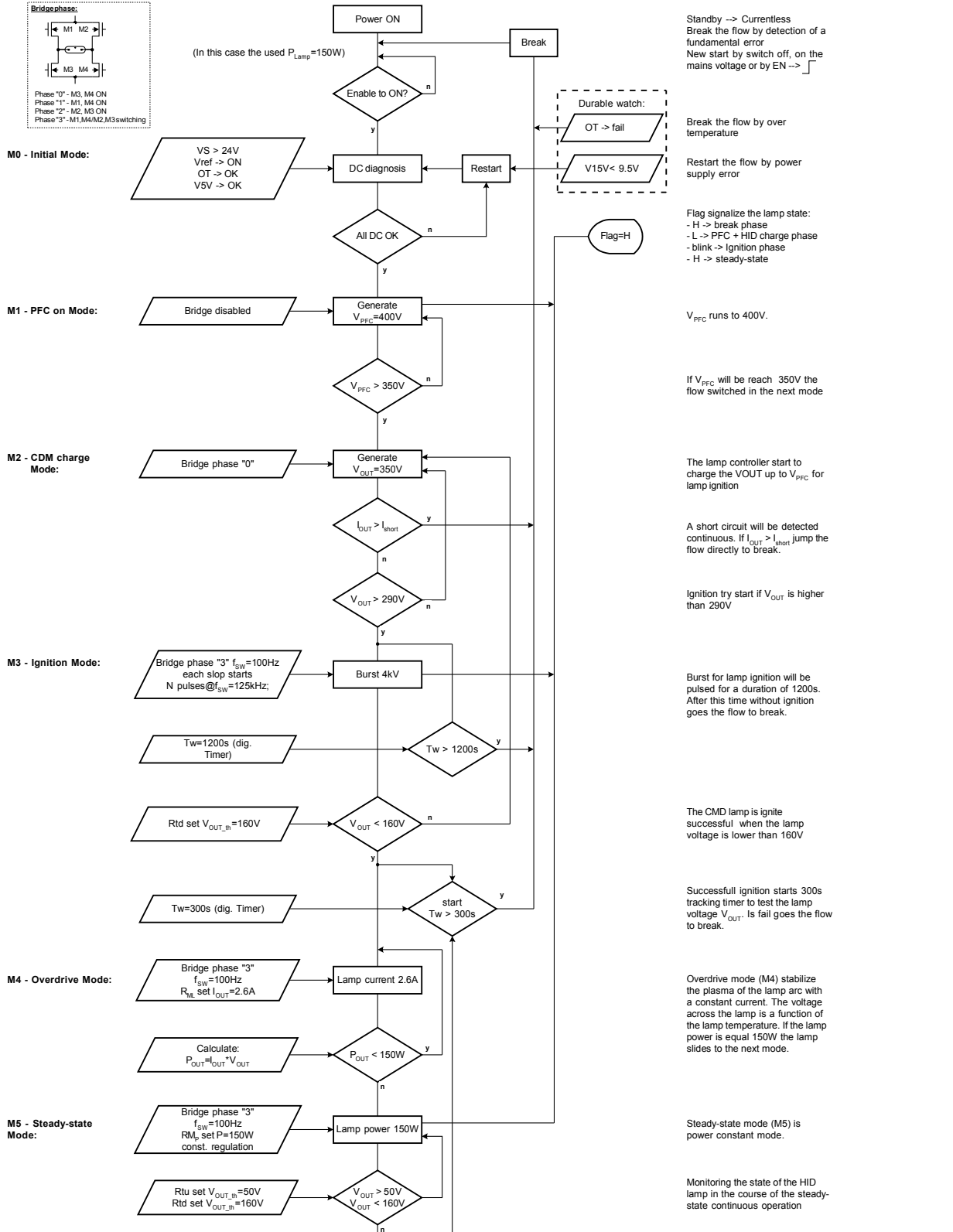

Zachstein: L30 03.09

10. Timing Diagrams

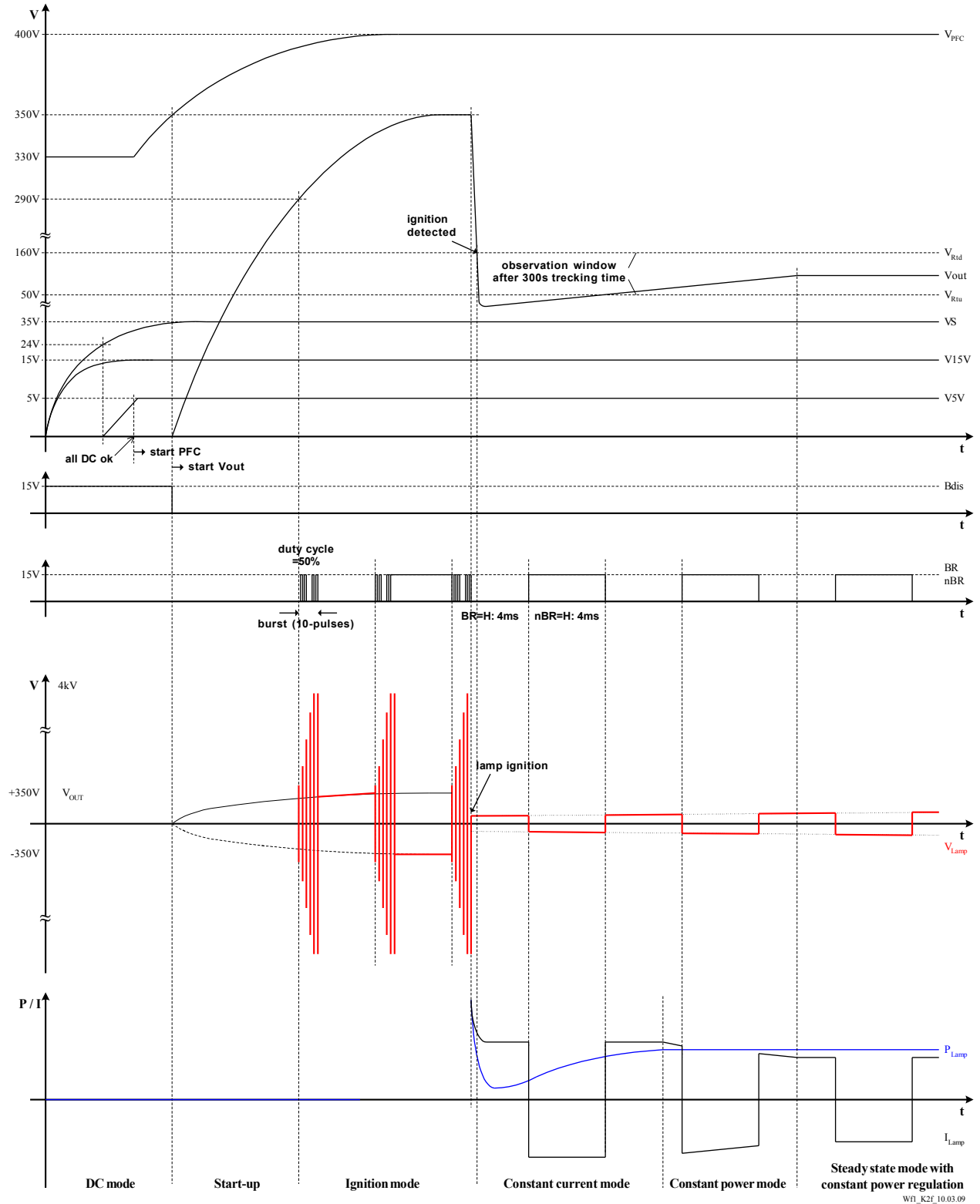

Ballast Controller for Metal Halide Lamps

11. Application

The chip set AMG-LM302 and AMG-DF102 are suitable to drive

11.1. Example Application Circuit(s)

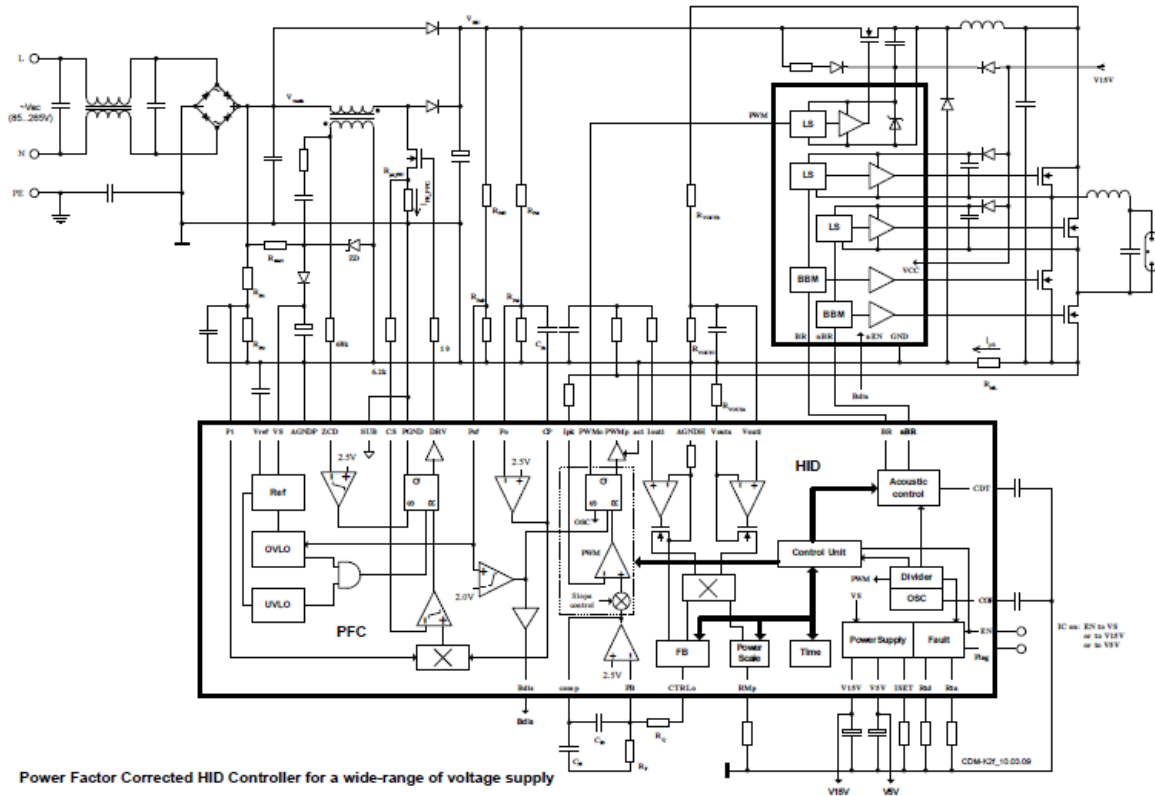

Figure 2: Example Application Circuit

11.2. Calculating PFC Parameters

- 1) Startup resistor (6.2-G.2):
$$R_{start} \leq \frac{V_{rmain_pk}}{I_{VS_STBY}} = V_{rmain_pk} \cdot 10^3$$
- 2) Input phase voltage divider (6.2-PFC-5):
$$\frac{R_{Pi2}}{R_{Pi1} + R_{Pi2}} \leq \frac{3}{V_{rmain_pk}}$$
- 3) VS voltage limitation (6.1-1):
$$V_{ZD} \leq VS_{max}$$
- 4) Output phase voltage divider:
$$\frac{R_{Po2}}{R_{Po1} + R_{Po2}} = \frac{2.5}{V_{PFC}}$$
- 5) Frequency compensation:
$$C_{Po} = tbd$$

Ballast Controller for Metal Halide Lamps

6) Over voltage and PFC ready voltage divider
$$\frac{R_{Pof2}}{R_{Pof1} + R_{Pof2}} = \frac{2.5}{V_{PFC_OV}}$$

7) PFC current sense resistor (6.2-PFC-9):
$$R_{pk_PFC} \leq \frac{V_{CS_cl}}{I_{PK_PFC}} = \frac{1.75}{I_{PK_PFC}}$$

11.3. Calculating HID Parameters

1) Biasing resistor:
$$R_{ISET} = 510k\Omega$$

2) Lamp voltage divider:
$$\frac{R_{VOUTC}}{R_{VOUTC} + R_{VOUTB}} = \frac{1}{100}$$

$$R_{VOUTA} = 10k\Omega$$

3) CDM current sense resistor:
$$R_{ML} = \frac{V_{IOUTi}}{I_{overdrive}} = \frac{0.625}{I_{overdrive}}$$

4) Power scale resistor:
$$R_{Mp} = \frac{3.906 \cdot 10^6}{P_{Lamp} \cdot R_{ML}}$$

5) Oscillator capacitor:
$$COP = \frac{|I_{COP_up} \cdot I_{COP_down}|}{F_{OSC} \cdot (I_{COP_down} - I_{COP_up}) \cdot (V_{COP_thH} - V_{COP_thL})}$$

$$COP = \frac{12.6}{F_{OSC} \cdot R_{ISET}}$$

6) Upper true voltage threshold:
$$R_{td} = \frac{1.25 \cdot 10^7}{V_{OUT_th}} \quad \text{for } V_{OUT_th} = 160V$$

7) Lower true voltage threshold:
$$R_{tu} = \frac{1.25 \cdot 10^7}{V_{OUT_th}} \quad \text{for } V_{OUT_th} = 50V$$

8) Bridge dead time capacitor
$$CDT \approx 1.67 \cdot 10^{-5} \cdot t_{DT}$$

9) Capacitor and resistor for frequency compensation at $F_{PWMo}=31kHz$

$$R_Q = 100k\Omega$$

$$R_F = tbd$$

$$C_{F1} = tbd$$

$$C_{F2} = tbd$$

Ballast Controller for Metal Halide Lamps

11.4. Application Notes

AMG-AN-LM302

12. IC-Package

TQFP48 (7*7, 48L)

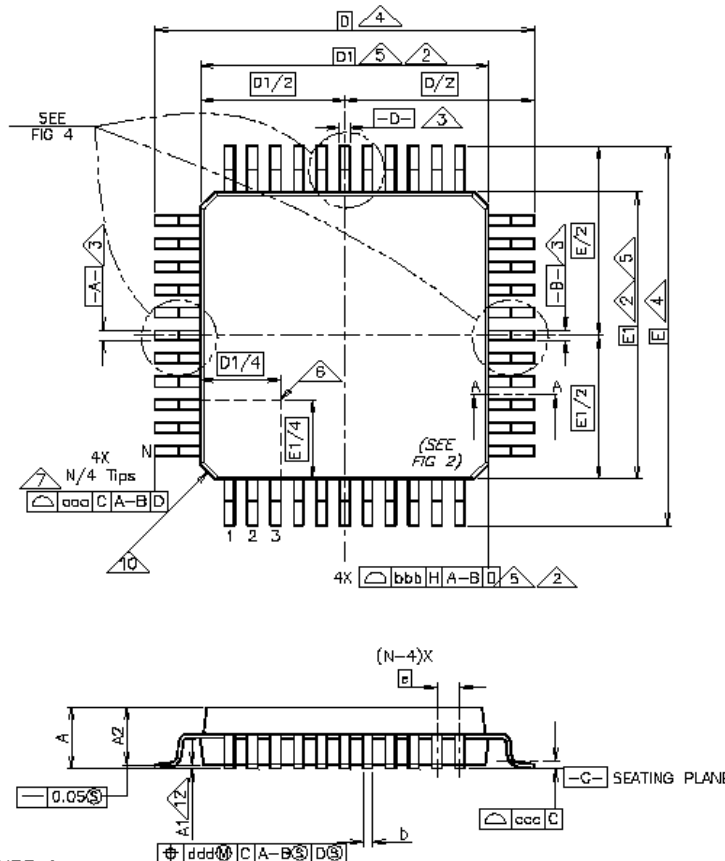

FIGURE 1

S y m b o l	MS-026			N o t e s
	ABC			
	Square			
	MIN	NOM	MAX	
A	1.00	1.10	1.20	
A1	0.05	0.10	0.15	
A2	0.95	1.00	1.05	
D	9.00 BSC			
D1	7.00 BSC			
E	9.00 BSC			
E1	7.00 BSC			
N	48			
e	0.50 BSC			
b	0.17	0.22	0.27	
b1	0.17	0.20	0.23	
Tolerance of form and position				
ccc	0.08			
ddd	0.08			

13. IC-Marking

aLM302

4 digits date code = 2 digits year + 2 digits work week

8 digits lot number = 2 digits fab process + 4 digits lot number + 1 digit sub lot

Ballast Controller for Metal Halide Lamps

14. Ordering Information

AMG-LM302-ITQ48T shipment in trays

15. Notes and Cautions

15.1. ESD Protection

The Requirements for Handling Electrostatic Discharge Sensitive Devices are described in the JEDEC standard JESD625-A. Please note the following recommendations:

- When handling the device, operators must be grounded by wearing a for the purpose designed grounded wrist strap with at least 1MΩ resistance and direct skin contact.
- Operators must at all times wear ESD protective shoes or the area should be surrounded by for ESD protection intended floor mats.
- Opening of the protective ESD package that the device is delivered in must only occur at a properly equipped ESD workbench. The tape with which the package is held together must be cut with a sharp cutting tool, never pulled or ripped off.
- Any unnecessary contact with the device or any unprotected conductive points should be avoided.
- Work only with qualified and grounded tools, measuring equipment, casing and workbenches.
- Outside properly protected ESD-areas the device or any electronic assembly that it may be part of should always be transported in EGB/ESD shielded packaging.

15.2. Storage conditions

The AMG-LM302 corresponds to moisture sensitivity classification **ML2** , according to JEDEC standard J-STD-020, and should be handled and stored according to J-STD-033.

16. Disclaimer

Information given in this data sheet is believed to be accurate and reliable. However, no responsibility is assumed for the consequences of its use nor for any infringement of patents or other rights of third parties that may result from its use.

The values stated in Absolute Maximum Ratings may under no circumstances be exceeded. No warranty is given for use in life support systems or medical equipment without the specific written consent of alpha microelectronics gmbh. For questions regarding the application please contact the publisher.

The declared data are only a description of the product. They are not guaranteed properties as defined by law. Examples are given without obligations and cannot give rise to any liability. Reprinting of this data sheet – or any part of it – is not allowed without the license of the publisher. Data sheets are subject to change without any notice.

Ballast Controller for Metal Halide Lamps

17. Contact Information

This data sheet is published by alpha microelectronics gmbh. To order samples or inquire information please contact:

alpha microelectronics gmbh
Im Technologiepark 1
15236 Frankfurt (Oder)
Germany

am.info@alpha-microelectronics.de
www.alpha-microelectronics.de

+49-335-557-1750 (telephone)
+49-335-557-1759 (fax)

© All rights reserved.

