



APS3606

Active Splitter for Analog/Digital
CATV Set-Top Boxes

ADVANCED PRODUCT INFORMATION - Rev 0.4

FEATURES

- Single Input, Triple Output Design
- High Linearity, Low Distortion Outputs Support Video Tuner Applications
- Wideband Operation: To Above 1 GHz
- 4.5 dB Typical Noise Figure at 3.5 dB Gain
- Extended Dynamic Range Gain Control, Independent for each RF path
- Single +5 V Supply
- Balanced 75 Ohm Inputs/Outputs
- RoHS Compliant/Lead Free

APPLICATIONS

- CATV Set-Top Boxes with Multiple Tuners, and Analog or Analog/Digital input signals.

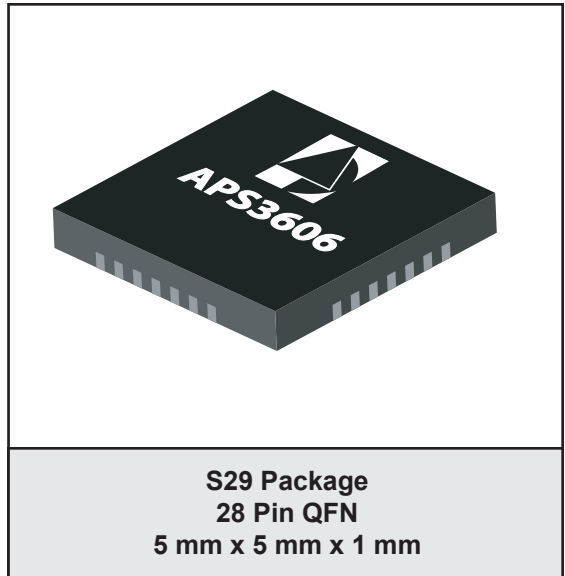

PRODUCT DESCRIPTION

This active splitter from ANADIGICS accepts a balanced RF input in the 50 MHz to 1.1 GHz frequency range and provides three balanced RF outputs with minimal degradation in signal quality. The single-package surface mount device amplifies the input signals using highly linear, low noise amplification stages, and couples the amplified signal to three separate output paths that can drive video tuner inputs.

Each of the RF paths includes independent Gain Control. The overall linearity of each path is maintained

across a wide gain range, ensuring low distortion effects on each output signal.

Requiring only a single +5 Volt supply, the active splitter design is implemented using the ANADIGICS GaAs MESFET process. The RoHS-compliant surface mount packaging makes the device ideal for use in today's multiple-tuner set-top boxes for Cable TV.

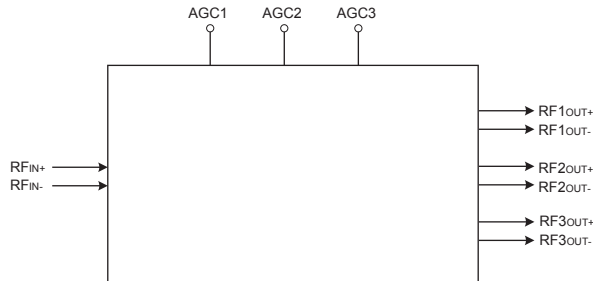

Figure 1: Functional Block Diagram

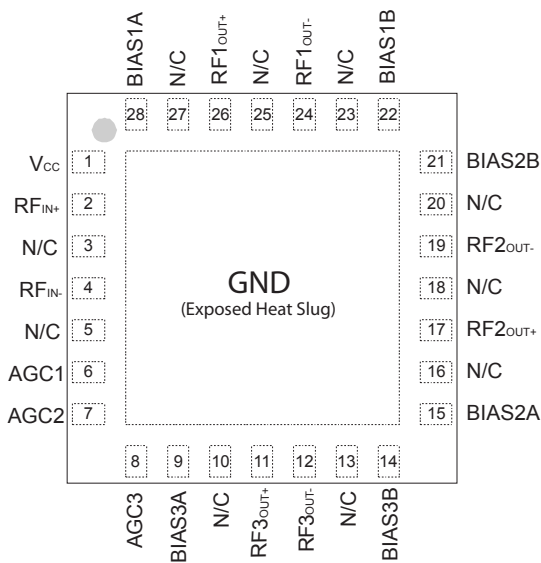

Figure 2: Pinout (X-ray Top View)

Table 1: Pin Description

PIN	NAME	DESCRIPTION	PIN	NAME	DESCRIPTION
1	V _{CC}	Supply Voltage	28	BIAS1A	RF1 Bias
2	RF _{IN+}	RF Input (+)	27	N/C	No Connection
3	N/C	No Connection	26	RF _{1OUT+}	RF1 Output (+)
4	RF _{IN-}	RF Input (-)	25	N/C	No Connection
5	N/C	No Connection	24	RF _{1OUT-}	RF1 Output (-)
6	AGC1	RF1 Gain Control Input	23	N/C	No Connection
7	AGC2	RF2 Gain Control Input	22	BIAS1B	RF1 Bias
8	AGC3	RF3 Gain Control Input	21	BIAS2B	RF2 Bias
9	BIAS3A	RF3 Bias	20	N/C	No Connection
10	N/C	No Connection	19	RF _{2OUT-}	RF2 Output (-)
11	RF _{3OUT+}	RF3 Output (+)	18	N/C	No Connection
12	RF _{3OUT-}	RF3 Output (-)	17	RF _{2OUT+}	RF2 Output (+)
13	N/C	No Connection	16	N/C	No Connection
14	BIAS3B	RF3 Bias	15	BIAS2A	RF2 Bias

ELECTRICAL CHARACTERISTICS

Table 2: Absolute Minimum and Maximum Ratings

PARAMETER	MIN	MAX	UNIT	COMMENTS
Supply Voltage (V_{CC})	0	+8	V	
AGC Input Voltage (V_{AGC})	0	+5	V	
RF Input Power (P_{IN})	-	+25	dBmV	differential into 75 Ω

Stresses in excess of the absolute ratings may cause permanent damage. Functional operation is not implied under these conditions. Exposure to absolute ratings for extended periods of time may adversely affect reliability.

Table 3: Operating Ranges

PARAMETER	MIN	TYP	MAX	UNIT	COMMENTS
Operating Frequency (f)	50	-	1100	MHz	
Supply Voltage (V_{CC})	-	+5	-	V	
AGC Input Voltage (V_{AGC})	+0.3	-	+3.0	V	max. gain at +3 V
RF Input Power (P_{IN})	-15	-	+15	dBmV	differential into 75 Ω
Case Temperature (T_C)	-20	-	+85	$^{\circ}$ C	

The device may be operated safely over these conditions; however, parametric performance is guaranteed only over the conditions defined in the electrical specifications.

Table 4: DC Electrical Specifications
(T_c = +25 °C, V_{cc} = +5 V, 75 Ω system)

PARAMETER	MIN	TYP	MAX	UNIT	COMMENTS
Current Consumption	-	175	-	mA	from +5 V supply
ACG Input Leakage Current	-	50	-	μA	each AGC input

Table 5: Video Tuner Path AC Electrical Specifications
(T_c = +25 °C, V_{cc} = +5 V, 75 Ω system)

PARAMETER	MIN	TYP	MAX	UNIT	COMMENTS
Gain at Maximum AGC	3	3.5	-	dB	at 1 GHz
Gain at Minimum AGC	-	-28	-	dB	at 1 GHz
AGC Range	-	33	-	dB	at 1 GHz
Noise Figure	-	4.3	-	dB	at maximum gain
CTB	-	-70	-66	dBc	see note 1
CSO - Channel 1	-	-66	-63	dBc	see note 1
CSO - Channel 2 & 3	-	-70	-66	dBc	see note 1
XMOD	-	-67	-	dBc	see note 1
Isolation Between Output and Any Other Output Port	-	35	-	dB	
Isolation Between Input and Output	-	35	-	dB	
Input Return Loss	-	-12	-	dB	75 Ω differential input
Output Impedance	-	75	-	Ω	differential

Notes:
(1) 132 channels, +6 dBmV flat output, up to +15 dBmV flat input

APPLICATION INFORMATION

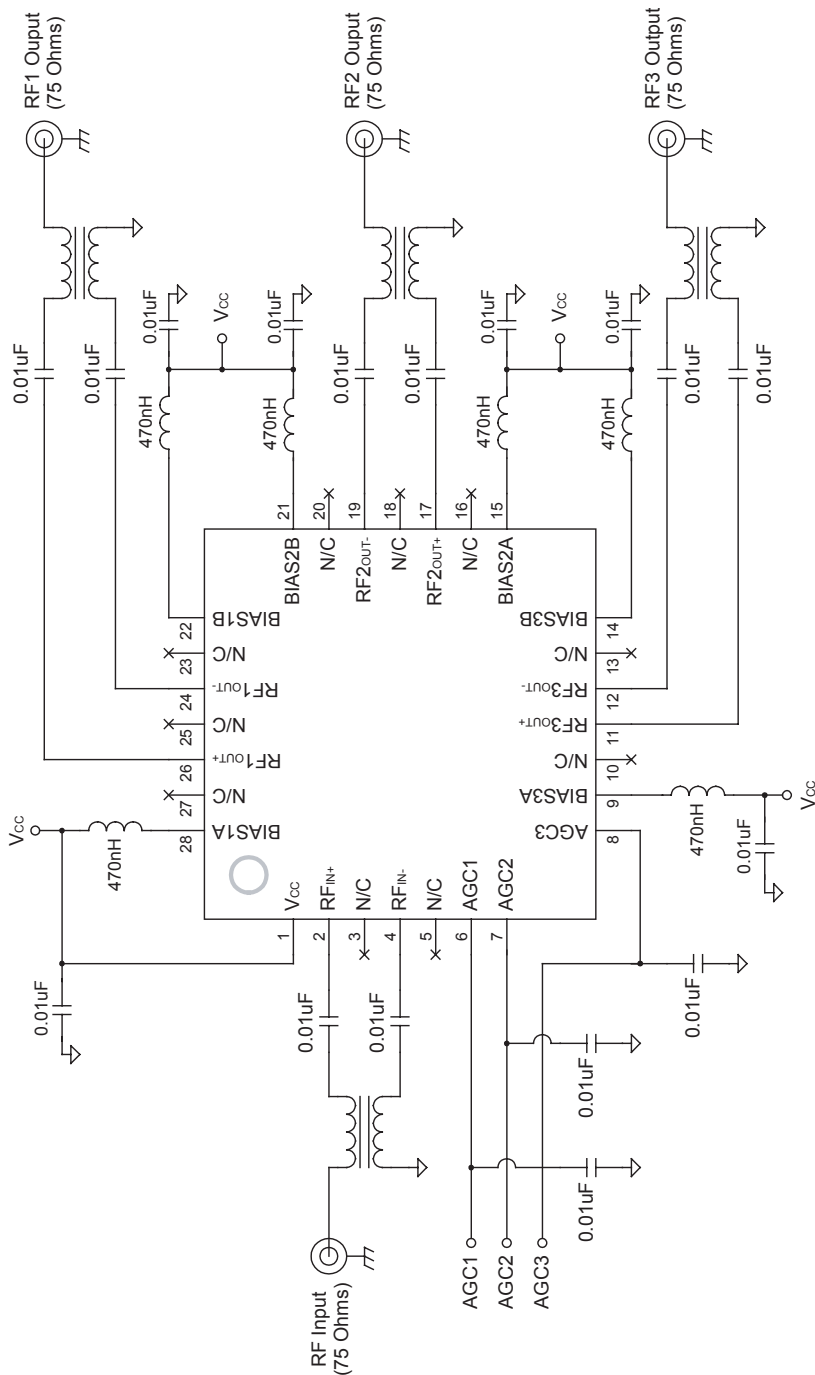
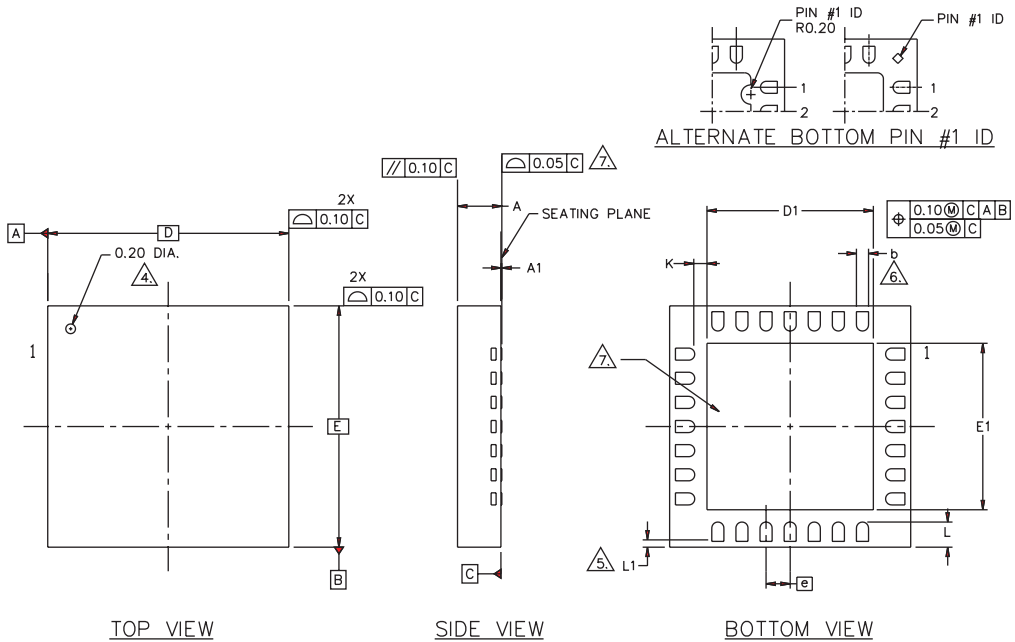

Figure 3: Application Circuit

PACKAGE OUTLINE



NOTES :

1. ALL DIMENSIONS ARE IN MILLIMETERS.
2. MAX. PACKAGE WARPAGE IS 0.05 mm.
3. MAXIMUM ALLOWABLE BURRS IS 0.076 mm IN ALL DIRECTIONS.
4. PIN #1 ID ON TOP WILL BE LASER MARKED.
5. A MAXIMUM 0.15mm PULL BACK (L1) MAYBE PRESENT, L MINUS L1 TO BE EQUAL TO OR GREATER THAN 0.30mm.
6. DIMENSION b APPLIES TO METALLIZED TERMINAL AND IS MEASURED BETWEEN 0.15 AND 0.30mm FROM TERMINAL TIP. IF THE TERMINAL HAS THE OPTIONAL RADIUS ON THE OTHER END OF THE TERMINAL, THE DIMENSION b SHOULD NOT BE MEASURED IN THAT RADIUS AREA.
7. BILATERAL COPLANARITY ZONE APPLIES TO THE EXPOSED HEAT SINK SLUG AS WELL AS THE TERMINALS.
8. REFERENCE JEDEC OUTLINE MO-220.

S V M B Q L	DIMENSIONS--MM		S V M B Q L	DIMENSIONS--INCHES		S V M B Q L
	MIN.	MAX.		MIN.	MAX.	
A	0.80	1.00	A	0.031	0.039	
A1	0.00	0.05	A1	0.000	0.002	
b	0.18	0.30	b	0.007	0.012	
D	5.00 BSC		D	0.197 BSC		
D1	3.30	3.55	D1	0.130	0.140	
E	5.00 BSC		E	0.197 BSC		
E1	3.30	3.55	E1	0.130	0.140	
e	0.50 BSC		e	0.020 BSC		
K	0.20 MIN.		K	0.007 MIN.		
L	0.30	0.57	L	0.012	0.022	
L1	0.15 MAX.		L1	0.006 MAX.		

Figure 4: S29 Package Outline - 28 Pin 5 mm x 5 mm x 1 mm QFN

NOTES

ORDERING INFORMATION

ORDER NUMBER	TEMPERATURE RANGE	PACKAGE DESCRIPTION	COMPONENT PACKAGING
APS3606RS29P8	-20 °C to +85 °C	RoHS Compliant 28 Pin 5 mm x 5 mm x 1 mm QFN Package	Tape and Reel, 2500 pieces per Reel



ANADIGICS, Inc.

141 Mount Bethel Road
Warren, New Jersey 07059, U.S.A.
Tel: +1 (908) 668-5000
Fax: +1 (908) 668-5132

URL: <http://www.anadigics.com>
E-mail: Mktg@anadigics.com

IMPORTANT NOTICE

ANADIGICS, Inc. reserves the right to make changes to its products or to discontinue any product at any time without notice. The product specifications contained in Advanced Product Information sheets and Preliminary Data Sheets are subject to change prior to a product's formal introduction. Information in Data Sheets have been carefully checked and are assumed to be reliable; however, ANADIGICS assumes no responsibilities for inaccuracies. ANADIGICS strongly urges customers to verify that the information they are using is current before placing orders.

WARNING

ANADIGICS products are not intended for use in life support appliances, devices or systems. Use of an ANADIGICS product in any such application without written consent is prohibited.