

3A, 18V High Efficiency Synchronous Step-Down Converter

DESCRIPTION

The BL9384 is a wide input range, high efficiency, DC-to-DC step-down switching regulator, capable of delivering up to 3A of output current. Current mode PWM control allows the use of small external components, such as ceramic input and output caps, as well as small inductors, while still providing low output ripples. On top of the integrated internal synchronous rectifier that eliminates external Schottky diode, Overall BL9384 is a highly efficient and robust solution for DC-DC step-down applications that requires wide input ranges.

BL9384 is available ESOP8 Packages.

FEATURES

- Wide Input Operating Range from 4.5V to 18V
- Capable of Delivering 3A
- No External Schottky Diode Needed
- Current Mode control
- 0.923V Reference for Low Output voltages
- Logic Control Shutdown
- Thermal shutdown and UVLO
- Available in ESOP8 Package

APPLICATIONS

- LCD TVs
- Notebook computers
- FPGA power supplies
- LED drivers

TYPICAL APPLICATION

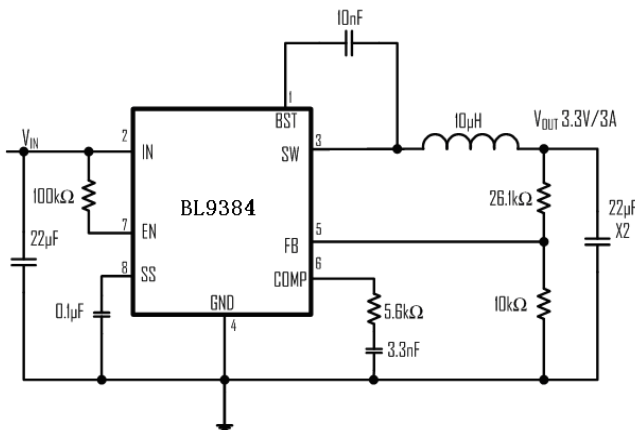

PIN OUT

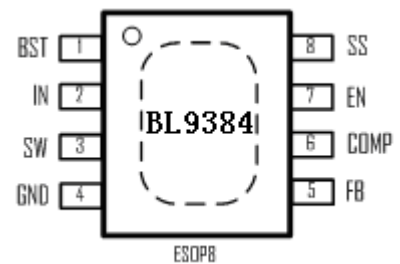

ABSOLUTE MAXIMUM RATING

Parameter	Value
Input Voltage Range	-0.3V-20V
SW, EN Voltage	-0.3V to VIN+0.3V
BST Voltage	-0.3V to SW+6V
FB Voltage	-0.3V to 6V
SW to ground curren	Internally limited
Operating Junction Temperature(Tj)	-40°C -85°C
Package Thermal Resistance (θ_{jc})	ESOP-8L 10°C / W
Storage Temperature(Ts)	-40°C - 150°C

Note: Exceed these limits to damage to the device. Exposure to absolute maximum rating conditions may affect device reliability.

ELECTRICAL CHARACTERISTICS

(VIN=12V, unless otherwise specified. Typical values are at TA=25°C)

Symbol	Parameter	Conditions	Min	Typ	Max	Unit
VDD	Input Voltage Range		5		18	V
UVLO_UP	UVLO,IN UVLO Rising	Rising, Hysteresis=140mV		3.55		V
Vref	Feedback Voltage		0.904	0.923	0.942	V
I _{fb}	Feedback Leakage current			0.01		uA
I _q	Quiescent Current	Active, V _{fb} =1V, No Switching		1		mA
		Shutdown		6		uA
	Error Amp Transconductance			800		μS
	Current Sense Transresistance			0.2		Ω
F _{sw}	Switching Frequency	V _{en} =2V, V _{in} =12V		340		KHz
R _{dsonP}	PMOS R _{dson}			120		mohm
R _{dsonN}	NMOS R _{dson}			100		mohm
I _{limit}	Peak Current Limit			3.5		A
V _{en}	EN Input Low Voltag		1	1.5	2	V
I _{en}	EN Input Current				1	μA
I _{sw}	SW Leakage Current	V _{in} =12V, V _{sw} =0 or 12V, EN= GND			10	μA
TSD	Over Temperature Proection			150		°C

TYPICAL PERFORMANCE CHARACTERISTICS

($V_{in}=12V$, $V_{out}=3.3V$, $L=10\mu H$, $C_{in}=10\mu F$, $C_{out}=22\mu F$, $T_A=25^\circ C$, unless otherwise stated)

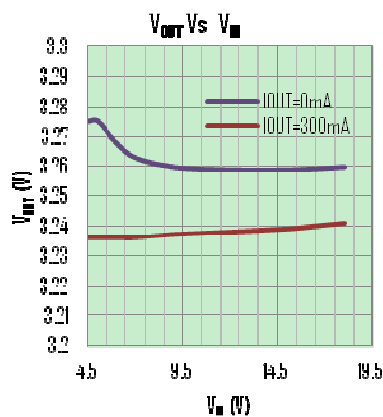
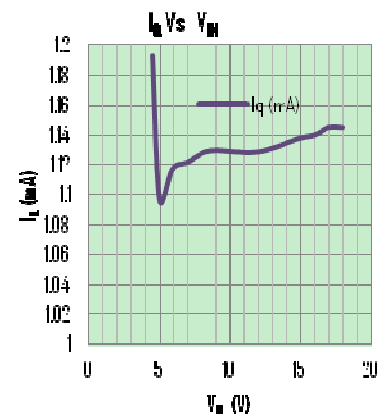
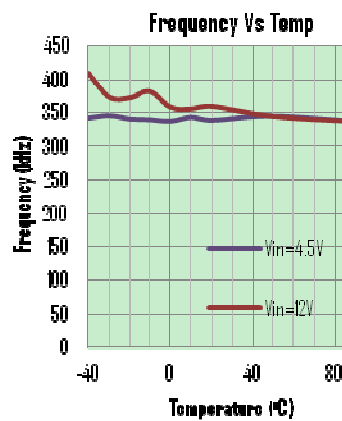
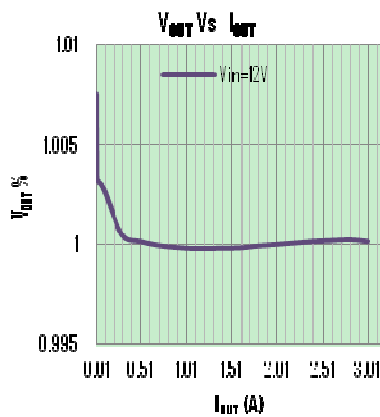

3A load Switching

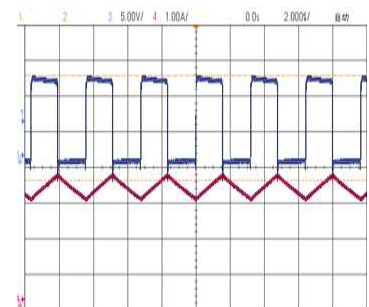

Start-up Waveform with Slow Vin

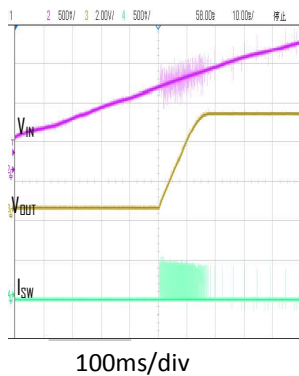

Start-up Waveform with

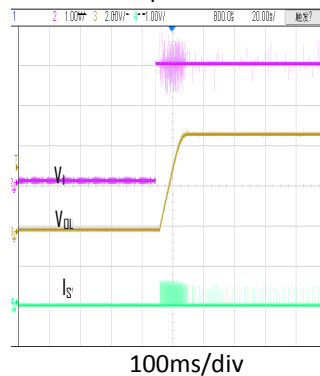

Load Transient Response

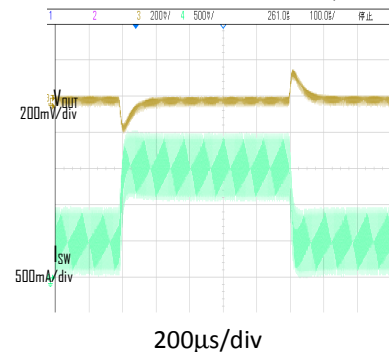

FUNCTIONAL DESCRIPTIONS

Loop Operation

The BL9384 is a wide input range, high-efficiency, DC-to-DC step-down switching regulator, capable of delivering up to 3A of output current, integrated with a 110mΩ synchronous MOSFET, eliminating the need for external diode. It uses a PWM current-mode control scheme. An error amplifier integrates error between the FB signal and the internal reference voltage. The output of the integrator is then compared to the sum of a current-sense signal and the slope compensation ramp. This operation generates a PWM signal that modulates the duty cycle of the power MOSFETs to achieve regulation for output voltage.

Current Limit

There is a cycle-by-cycle current limit on the high-side MOSFET of 3A(typ). When the current flowing out of SW exceeds this limit, the high-side MOSFET turns off and the synchronous rectifier turns on. Unlike the traditional method of current limiting by limiting the voltage at the compensation pin, which usually has large variation due to duty cycle variance, this type of peak current limiting scheme provides a relatively more accurate limit for output current, thereby lowering the requirements for system design.

COMPONENT SELECTION

When setting up the BL9384 for different output voltage, please use following recommended component value for the best performance.

V _{OUT} (V)	C _{OUT} (μF)	L (μH)
8	22x2	22
5	22x2	15
3.3	22x2	10
2.5	22x2	6.8
1.8	22x2	4.7
1.2	22x2	3.3

PACKAGE OUTLINE

