

SI-8000SD Series

Surface Mount, Separate Excitation Step-down Switching Mode Regulator ICs

Features

- Surface-mount package (TO263-5)
- Output current: 3.0A
- High efficiency: 79% typ. (SI-8033SD), 84% typ. (SI-8050SD)
- Requires only 4 discrete external components
- Internally-adjusted phase correction and output voltage
- Built-in reference oscillator (60kHz)
- Built-in overcurrent and thermal protection circuits
- Output ON/OFF available
- Soft start available by S.S pin

Lineup

Part Number	SI-8033SD	SI-8050SD
V _o (V)	3.3	5.0
I _o (A)	3	

Absolute Maximum Ratings

Parameter	Symbol	Ratings	Unit	Conditions
DC Input Voltage	V _{IN}	43*1	V	
Power Dissipation*2	P _D	3	W	When mounted on glass-epoxy board 40 × 40 mm (copper area: 100%)
Junction Temperature	T _j	+125	°C	
Storage Temperature	T _{stg}	-40 to +125	°C	
Thermal Resistance (Junction to Case)	θ _{J-C}	3	°C/W	
Thermal Resistance (Junction to Ambient Air)	θ _{J-A}	33.3	°C/W	When mounted on glass-epoxy board 40 × 40 mm (copper area: 100%)

*1: 35V for SI-8033SD

*2: Limited by thermal protection circuit.

Applications

- Power supplies for telecommunication equipment
- Onboard local power supplies

Recommended Operating Conditions

Parameter	Symbol	Ratings		Unit
		SI-8033SD	SI-8050SD	
DC Input Voltage Range	V _{IN1}	5.5 to 28	7 to 40	V
Output Current Range*	I _o	0 to 3.0		A
Operating Junction Temperature Range	T _{jop}	-30 to +125		°C
Operating Temperature Range*	T _{op}	-30 to +125		°C

*: Limited by Ta-Pd characteristics.

Electrical Characteristics

(T_a=25°C)

Parameter	Symbol	Ratings						Unit
		SI-8033SD			SI-8050SD			
		min.	typ.	max.	min.	typ.	max.	
Output Voltage	V _o	3.17	3.3	3.43	4.8	5.0	5.2	V
	Conditions	V _{IN} =15V, I _o =1A			V _{IN} =20V, I _o =1A			
Efficiency	η	79			84			%
	Conditions	V _{IN} =15V, I _o =1A			V _{IN} =20V, I _o =1A			
Oscillation Frequency	f	60			60			kHz
	Conditions	V _{IN} =15V, I _o =1A			V _{IN} =20V, I _o =1A			
Line Regulation	ΔV _{OLINE}	25		80	40		100	mV
	Conditions	V _{IN} =8 to 28V, I _o =1A			V _{IN} =10 to 30V, I _o =1A			
Load Regulation	ΔV _{OLOAD}	10		30	10		40	mV
	Conditions	V _{IN} =15V, I _o =0.5 to 1.5A			V _{IN} =20V, I _o =0.5 to 1.5A			
Temperature Coefficient of Output Voltage	ΔV _o /ΔT _a	±0.5			±0.5			mV/°C
Overcurrent Protection Starting Current	I _{s1}	3.1			3.1			A
	Conditions	V _{IN} =15V			V _{IN} =20V			
Soft Start Pin*	Low-Level Voltage	V _{SSL}			0.2			V
	Outflow Current at Low Voltage	I _{SSL}			20, 30, 40			
		V _{SSL} =0.2V						μA

* Pin 5 is a soft start pin. Soft start at power on can be performed with a capacitor connected to this pin.

The output can also be turned ON/OFF with this pin.

The output is stopped by setting the voltage of this pin to V_{SSL} or lower.

Soft-start pin voltage can be changed with an open-collector drive circuit of a transistor.

When using both the soft-start and ON/OFF functions together, the discharge current from C₃ flows into the ON/OFF control transistor. Therefore, limit the current securely to protect the transistor if C₃ capacitance is large.

The ON/OFF pin is pulled up to the power supply in the IC, so applying the external voltage is prohibited.

If this pin is not used, leave it open.

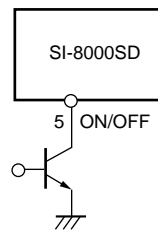

V_{OUT}. ON/OFF

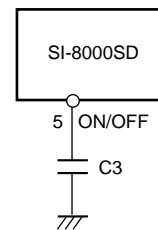

Soft start

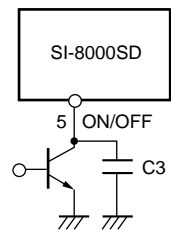

Soft start +V_{OUT}. ON/OFF

External Dimensions (TO263-5)

(Unit : mm)

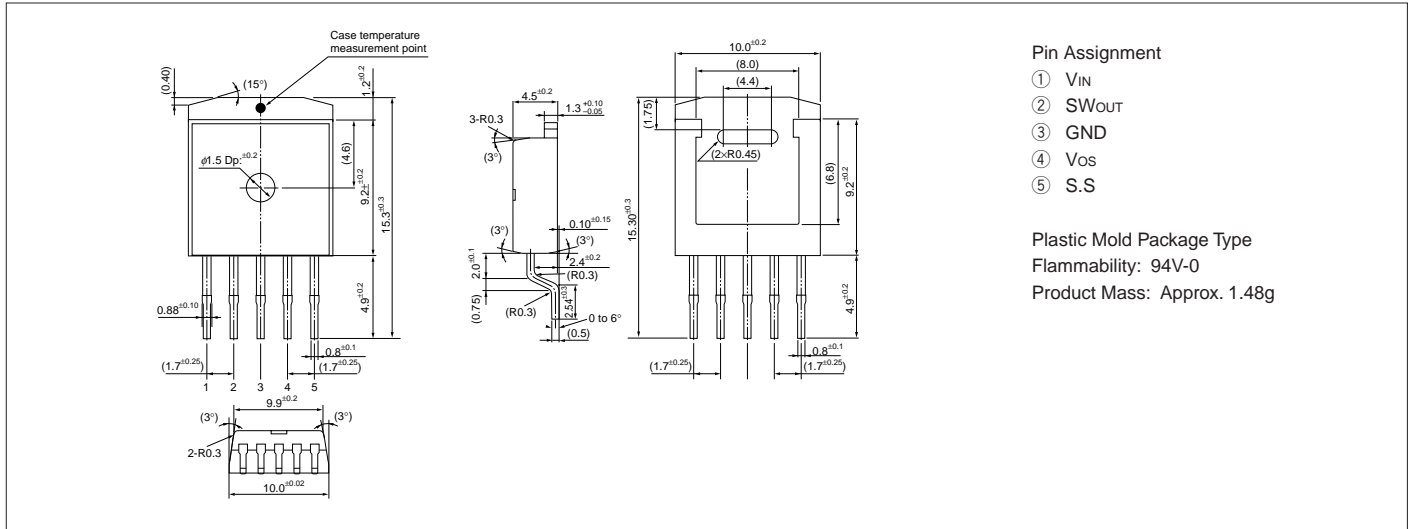

Block Diagram

Reference Data

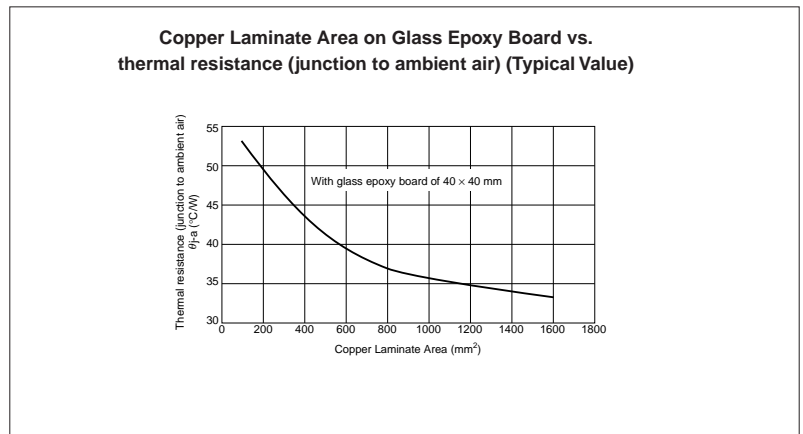
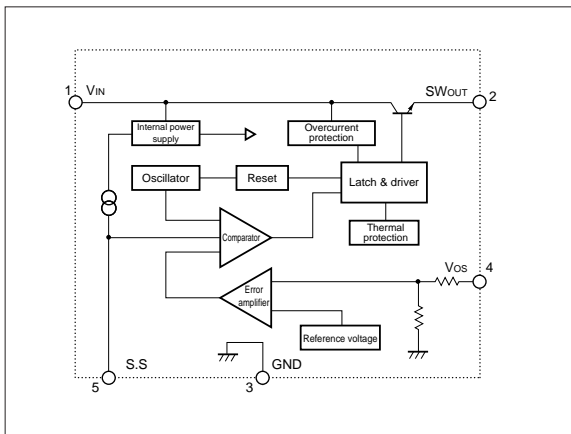

Typical Connection Diagram

