



TAI-SAW TECHNOLOGY CO., LTD.

No. 3, Industrial 2nd Rd., Ping-Chen Industrial District,
Taoyuan, 324, Taiwan, R.O.C.

TEL: 886-3-4690038 FAX: 886-3-4697532

E-mail: tstsales@mail.taisaw.com Web: www.taisaw.com

Approval Sheet For Product Specification

Issued Date:

Product Name: SAW Resonator 622.41 MHz SMD 3X3 mm

TST Parts No.: TC0302A

Customer Parts No.: _____

Company: _____
Division: _____
Approved by : _____
Date: _____

Checked by: _____ Asin Lin

Approval by: _____ Francis Chen

Date: _____ 2005/08/12



TAI-SAW TECHNOLOGY CO., LTD.

No. 3, Industrial 2nd Rd., Ping-Chen Industrial District,
Taoyuan, 324, Taiwan, R.O.C.

TEL: 886-3-4690038 FAX: 886-3-4697532

E-mail: tstsales@mail.taisaw.com Web: www.taisaw.com

SAW Resonator 622.41 MHz

MODEL NO.: TC0302A

REV. NO.:1

A. FEATURES:

- 1. 1-Port Resonator.

B. MAXIMUM RATING:

- 1. Input Power Level: 0 dBm
- 2. DC voltage: 5 V
- 3. Operating Temperature: -40°C to +85°C
- 4. Storage Temperature: -40°C to +85°C

C. ELECTRICAL CHARACTERISTICS:

Reference Temperature $T_A=25^\circ\text{C}$

Characteristic	Units	Minimum	Typical	Maximum
Center frequency Fc	MHz	622.375	622.41	622.445
Insertion Loss IL	dB	-	1.3	2.0
Unload quality factor Q_U		-	11300	-
Ageing of fc	ppm/yr	-	-	±10
Motional capacitance C1	fF	-	1.55	-
Motional inductance L1	µH	-	42.14	-
Motional resistance R1	Ohm	-	15.3	-
Parallel capacitance C₀	pF	-	2.82	-
Frequency Temperature coefficient C_f)	ppm/c*2	-	0.032	-
Turnover T_o	deg.C	-	25	-
Package size		SMD 3x3x1.1 mm		

Temperature dependence of fc: $f_c(T_A)=f_c(T_O)(1+TC_f(T_A-T_O)^2)$

D. EQUIVRENT CIRCUIT:

One-Port Resonator:

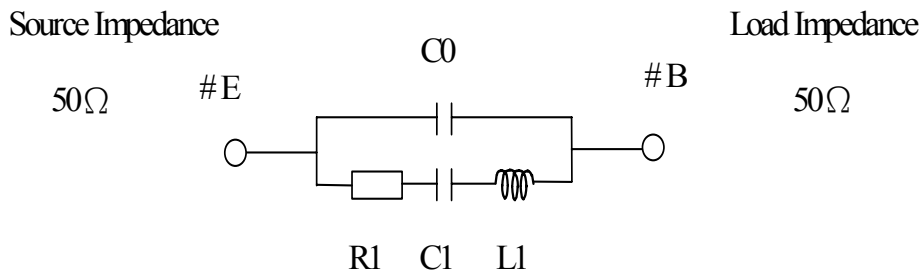

RoHS Compliant
Lead free
Lead-free soldering

E. OUTLINE DRAWING:

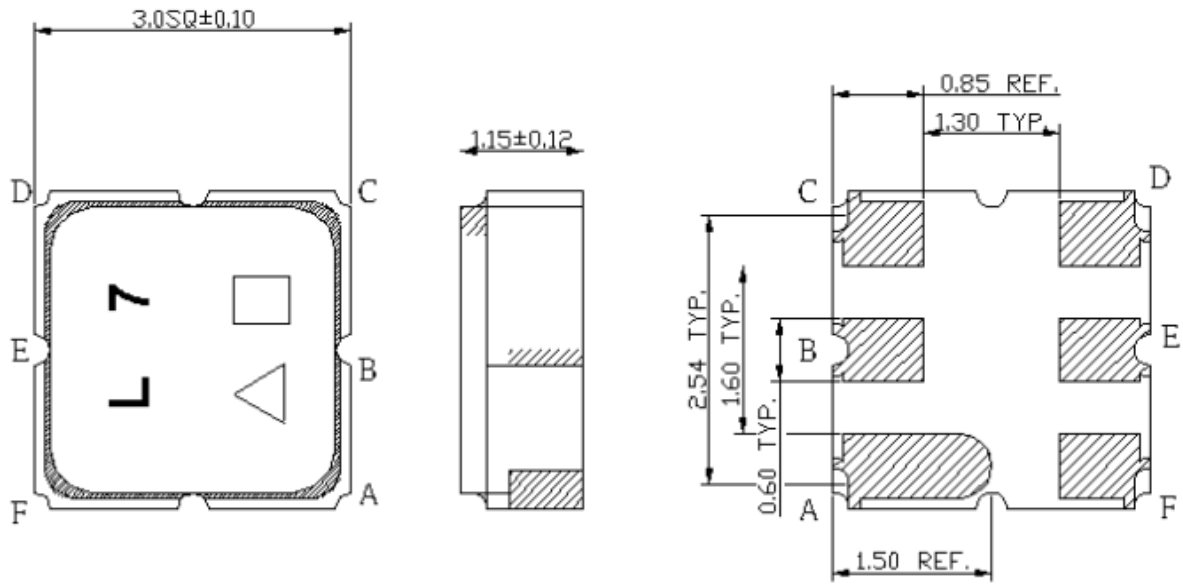

Pin B: Input or Output ; Pin E: Output or Input
 Pin A,C,D,F: Ground
 △ : Year Code
 □ : Date Code
 Unit : mm

F. FREQUENCY CHARACTERISTICS:



G. TEST CIRCUIT:

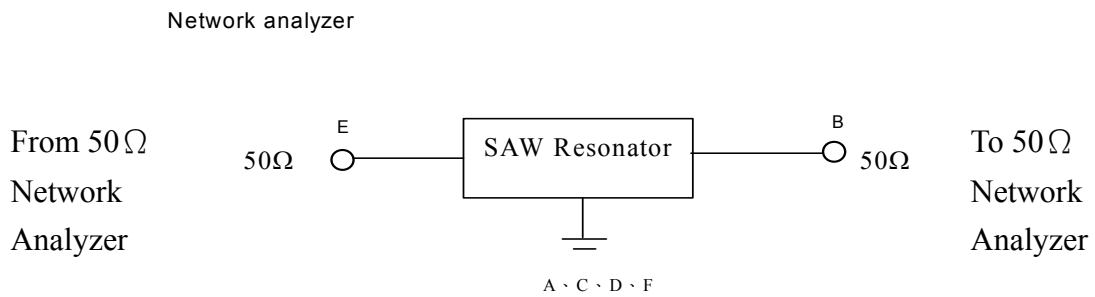

H. LAND PATTERN:

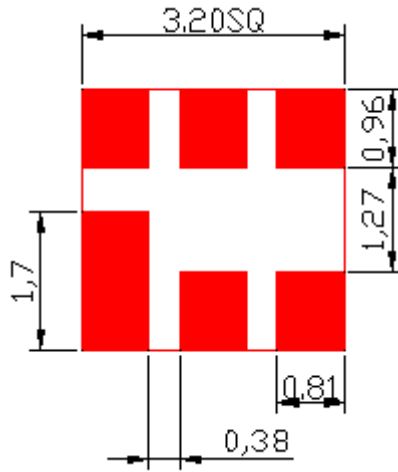

I. PACKING:

1. REEL DIMENSION

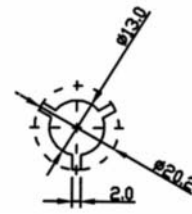
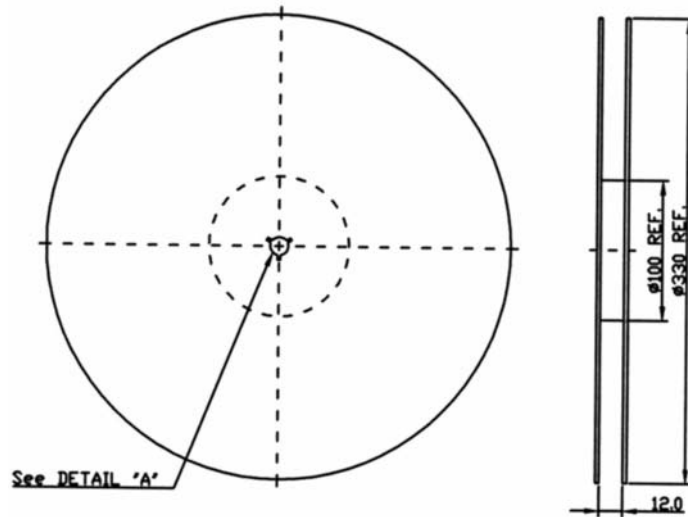

2. TAPE DIMENSION

