

TOSHIBA Bi-CMOS INTEGRATED CIRCUIT SILICON MONOLITHIC

TD62C853F,TD62C854F

8BIT SERIAL-IN PARALLEL-OUT SHIFT REGISTER / LATCH DRIVERS

The TD62C853F and TD62C854F are monolithic circuits designed to be used together with Bi-CMOS integrated circuits. The devices consist of a 8 bit shift register, 8 bit latches, and 8 output circuits.

FEATURES

- 8 bit serial-in parallel-out shift register / latch driver (Bi-CMOS process)
- Maximum output sustaining voltage ; 50 V
- Maximum output current ;
TD62C853F 200 mA / ch (Low saturation type)
TD62C854F 500 mA / ch (darlington type)
- CMOS compatible inputs
- Package ; SSOP24-P-300-1.00

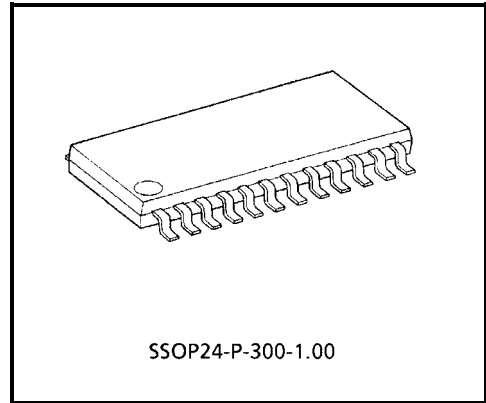

Weight: 0.32 g (Typ.)

Note: S-OUT pin is sensitive against Latch-up. (Latch-up performance is under 30 mA)
Please connect an external resistor to S-OUT pin in series due to protect this device from Latch-up. (Recommended resistance: R = 100 [Ω])

PIN CONNECTION (TOP VIEW)

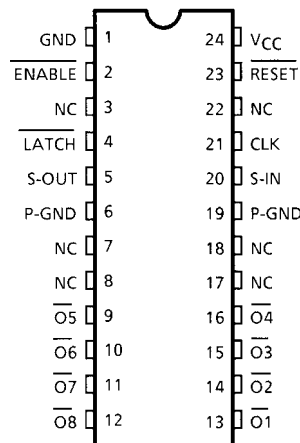

BLOCK DIAGRAM

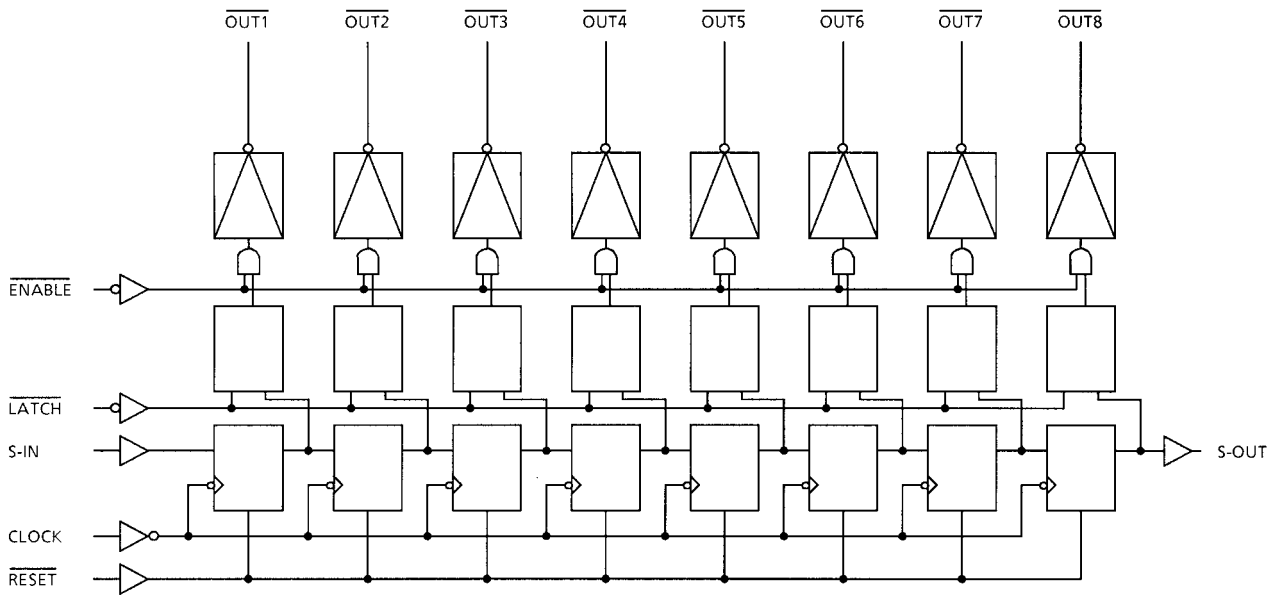

TIMING DIAGRAM

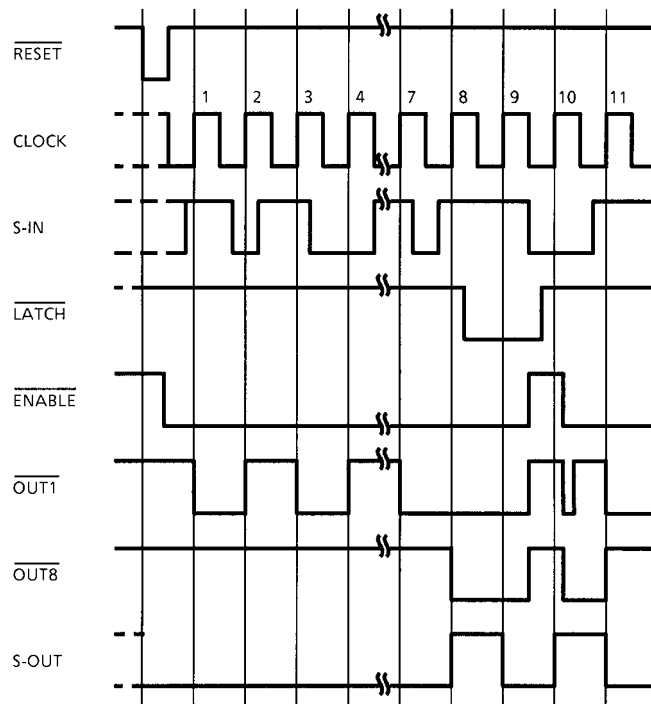

EQUIVALENT CIRCUITS OF INPUTS AND OUTPUTS

S-IN, CLOCK terminal equivalent circuits

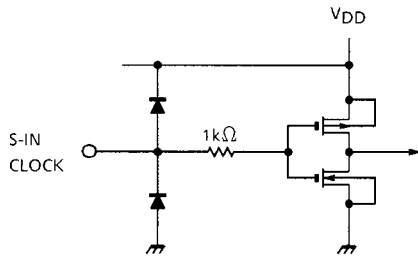

LATCH, RESET terminal equivalent circuits

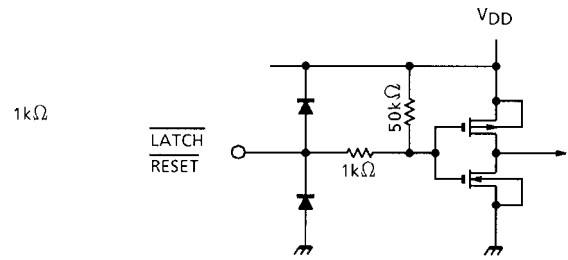

ENABLE terminal equivalent circuits

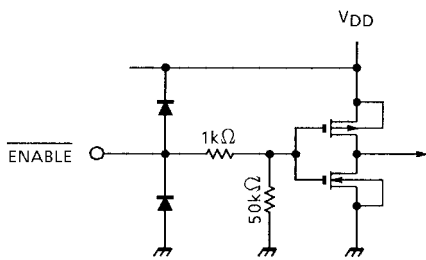

S-OUT terminal equivalent circuits

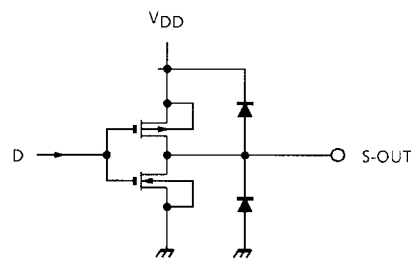

Output terminal equivalent circuits (TD62C853F)

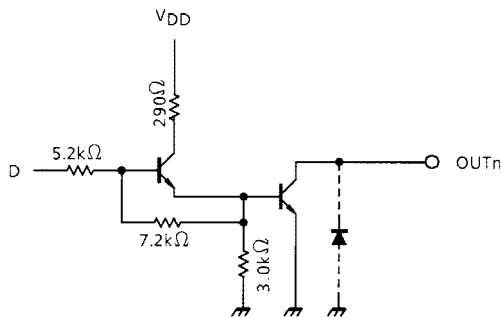

Output terminal equivalent circuits (TD62C854F)

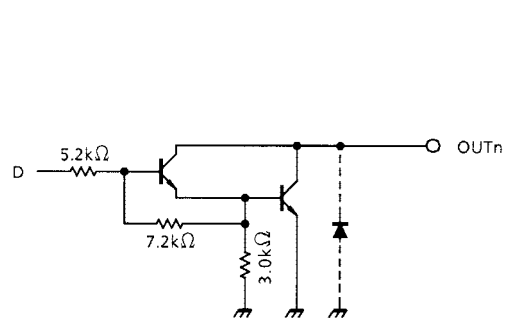

Note: The output parasitic diode cannot be used as clamp diode.

TRUTH TABLE

CK	\bar{E}	\bar{R}	$\overline{\text{LATCH}}$	S-IN	OUT		S-OUT
					$\bar{O}1$	$\bar{O}n$	
	L	H	H	L	OFF	$\bar{O}n-1$	Q ₇
	L	H	H	H	ON	$\bar{O}n-1$	Q ₇
	L	H	L	(*)	NC	NC	Q ₇
	H	H	(*)	(*)	OFF	NC	Q ₇
	(*)	(*)	(*)	(*)	NC	NC	Q ₇
(*)	(*)	L	H	(*)	OFF	OFF	L
(*)	H		L	(*)	NC	NC	L

<p>CK = CLOCK E = ENABLE R = RESET LATCH = LATCH S-IN = SERIAL IN OUT = PARALLEL OUT S-OUT = SERIAL OUT</p>	<p>(*) = DON'T CARE NC = NO CHANGE L = LOW LEVEL H = HIGH LEVEL</p>
---	--

MAXIMUM RATINGS (Ta = 25°C)

CHARACTERISTIC	SYMBOL	RATING	UNIT
Supply Voltage	V _{DD}	-0.3~7.0	V
Output Sustaining Voltage	V _{CE (SUS)}	-0.5~50	V
Output Current	TD62C853P	200	mA / ch
	TD62C854P	500	
Input Voltage	V _{IN}	~0.4~V _{DD} + 0.3	V
Power Dissipation	P _D	830 (Note)	mW
Operating Temperature	T _{opr}	-40~85	°C
Storage Temperature	T _{stg}	-55~150	°C

Note: On PCB (50 × 50 × 1.6 mm Cu 30% Glass Epoxy PCB)
The derating factor above Ta = 25°C: 6.6 mW / °C

PRECAUTIONS for USING

This IC does not integrate protection circuits such as overcurrent and overvoltage protectors.

Thus, if excess current or voltage is applied to the IC, the IC may be damaged. Please design the IC so that excess current or voltage will not be applied to the IC.

Utmost care is necessary in the design of the output line, V_{DD} and GND line since IC may be destroyed due to short-circuit between outputs, air contamination fault, or fault by improper grounding.

RECOMMENDED OPERATING CONDITIONS (Ta = -40~85°C)

CHARACTERISTIC		SYMBOL	CONDITION	MIN	TYP.	MAX	UNIT	
Supply Voltage		V _{DD}	—	4.5	5.0	5.5	V	
Input Voltage		V _{IN}	—	0	—	V _{DD}	V	
Output Current ("H" Level)	S-OUT	I _{OH}	Ta = 25°C	—	—	-0.4	mA	
Output Voltage ("L" Level)	$\overline{O}n$	V _{OH}	—	0	—	50	V	
Output Current ("L" Level)	S-OUT	I _{OL}	—	—	—	0.4	mA / ch	
			DC 1 circuit, Ta = 25°C	0	—	160		
	8 circuits on T _{pw} = 25 ms Ta = 85°C V _{DD} = 5.5 V		Duty = 10%	0	—	160		
			Duty = 40%	0	—	55		
	TD62C853F		$\overline{O}n$	DC 1 circuit, Ta = 25°C	0	—		360
				8 circuits on T _{pw} = 25 ms Ta = 85°C V _{DD} = 5.5 V	Duty = 10%	0		—
Duty = 50%	0	—	170					
Clock Frequency		f _{CLOCK}	—	1.5	—	—	MHz	
Clock Pulse Width		f _w CLOCK	—	0.33	—	—	μs	
Data Set Up Time		t _{setup}	—	100	—	—	ns	
Data Hold Time		t _{hold}	—	100	—	—	ns	

ELECTRICAL CHARACTERISTICS (Ta = -40~85°C)

CHARACTERISTIC		SYMBOL	TEST CIR-CUIT	TEST CONDITION	MIN	TYP.	MAX	UNIT			
Input Voltage	"H" Level	V _{IH}	—	—	0.7 V _{DD}	—	—	V			
	"L" Level	V _{IL}	—	—	—	—	0.3 V _{DD}				
Input Current	"H" Level	I _{IH}	—	ENABLE, V _{DD} = 5.5 V V _{IH} = V _{DD}	28	55	110	μA			
	"L" Level	I _{IL}	—	LATCH, RESET V _{DD} = 5.5 V, V _{IL} = GND	-55	-110	-275				
		I _{IN}	—	CLOCK, S-IN V _{IN} = V _{CC} or GND	—	—	±1.0				
Output Voltage	"H" Level	S-OUT	V _{OH}	—	V _{DD} = 4.5 V I _{OH} = -10 μA	3.9	4.1	—	V		
	"L" Level	S-OUT	V _{OL}	—	V _{DD} = 4.5 V	I _{OL} = 0.8 mA	—	0.2	0.4	V	
		On				TD62C853F	I _{OL} = 100 mA	—	0.29		0.50
						TD62C854F	I _{OL} = 160 mA	—	0.39		0.65
		I _{OL} = 250 mA					—	1.24	1.90		
I _{OL} = 400 mA	—	1.54	2.30								
Output Current	"H" Level	On	I _{OH}	—	V _{DD} = 5.5 V, V _{OH} = 50.0 V	—	—	100	μA		
Operating Supply Current			I _{DD1}	—	V _{DD} = 5.5 V Ta = 25°C	ENABLE = "H"	—	130	200	mA	
			I _{DD2}			f _{CLK} = 1 MHz Output open DATA = 1 / 2 f _{CLK}	—	2.0	5.0		
		TD62C853F	I _{DD3}			1 circuit on f _{CLK} = 1 MHz ENABLE = "L"	—	35	40		
		TD62C854F				—	1.0	1.4			

SWITCHING CHARACTERISTICS (Ta = 25°C)

CHARACTERISTIC			SYMBOL	TEST CIR-CUIT	TEST CONDITION	MIN	TYP.	MAX	UNIT
Propagation Delay Time	Low-to-High	CK-S-OUT	t_{pLH}	—	$V_{DD} = 5.0\text{ V}, V_{IH} = 5.0\text{ V}$ $V_{IL} = 0\text{ V}, \text{Duty} = 50\%$ $R_L = \begin{cases} 300\Omega \text{ (TD62C853F)} \\ 120\Omega \text{ (TD62C854F)} \end{cases}$	—	0.40	0.65	μs
		$\overline{\text{CK}}-\overline{\text{On}}$				—	1.80	3.00	
		$\overline{\text{L}}-\overline{\text{On}}$				—	2.10	3.50	
		$\overline{\text{R}}-\overline{\text{On}}$				—	1.50	2.50	
		$\overline{\text{E}}-\overline{\text{On}}$				—	1.50	2.50	
	High-to-Low	CK-S-OUT	t_{pHL}	—		—	0.33	0.55	
		$\overline{\text{CK}}-\overline{\text{On}}$				—	0.41	0.70	
		$\overline{\text{L}}-\overline{\text{On}}$				—	0.30	0.50	
		R-S-OUT				—	0.25	0.42	
		$\overline{\text{E}}-\overline{\text{On}}$				—	0.21	0.35	
Maximum Clock Frequency			f_{MAX}	—	1.5	2.0	—	MHz	
Minimum Pulse Width	CLOCK		t_{wCK}	—	—	250	330	ns	
	$\overline{\text{LATCH}}$		t_{wL}		—	116	160		
	$\overline{\text{RESET}}$		t_{wR}		—	107	140		
Data Set Up Time			t_{setup}	—	—	30	60	ns	
Data Hold Time			t_{hold}	—	—	14	40		
Maximum Clock Rise Time			t_r	—	—	70	—	ns	
Maximum Clock Fall Time			t_f	—	—	70	—		

Fig.1 I_{OUT} - V_{CE(sat)}

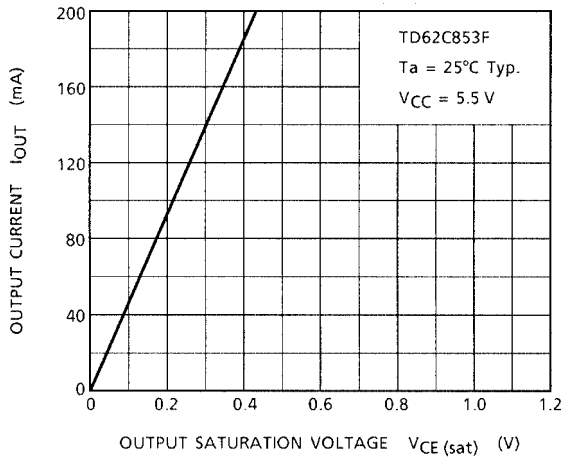
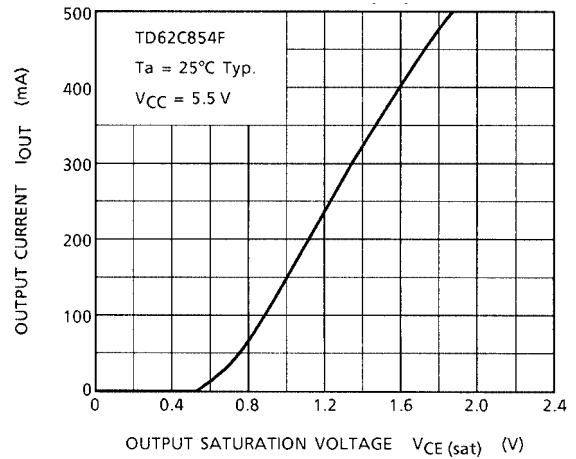

Fig.2 I_{OUT} - V_{CE(sat)}



TD62C853F each characteristic data and reference graph

Output current I_{OUT} vs lighting rate DUTY,
Condition : 1~8 circuit operation, V_{DD} = 5.5 V

Fig.3 DUTY - I_{OUT}
(Topr = 85°C)

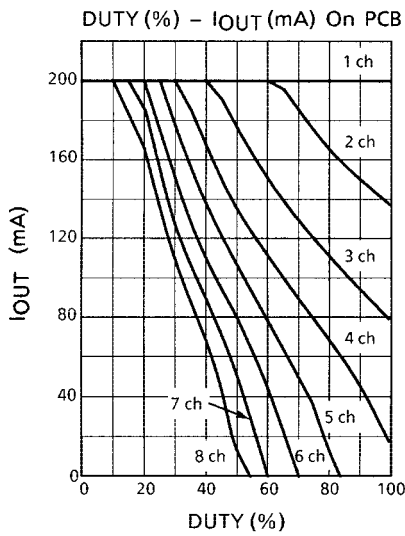

Fig.4 DUTY - I_{OUT}
(Topr = 55°C)

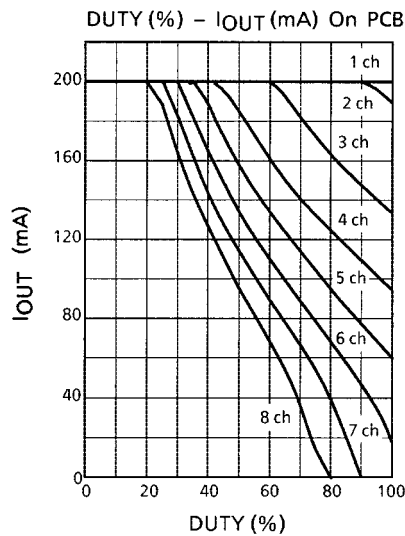
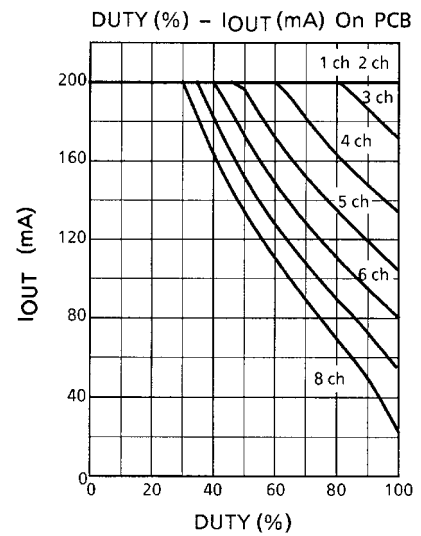

Fig.5 DUTY - I_{OUT}
(Topr = 25°C)



TD62C854F each characteristic data and reference graph

Output current I_{OUT} vs lighting rate DUTY,
 Condition: 1~8 circuit operation, $V_{DD} = 5.5\text{ V}$

Fig.6 DUTY - I_{OUT}
 ($T_{opr} = 85^{\circ}\text{C}$)

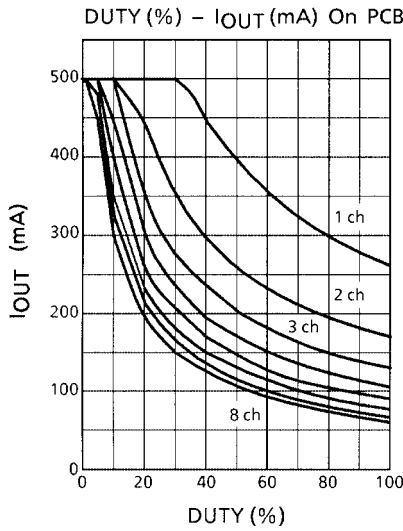

Fig.7 DUTY - I_{OUT}
 ($T_{opr} = 55^{\circ}\text{C}$)

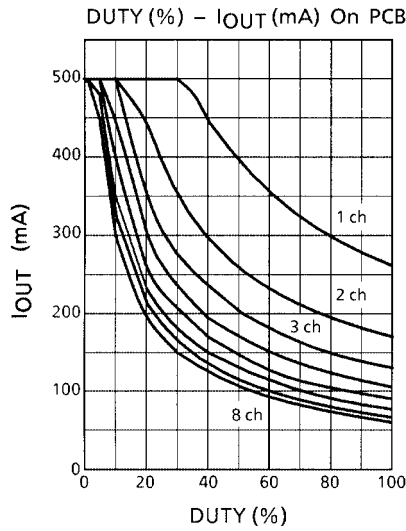
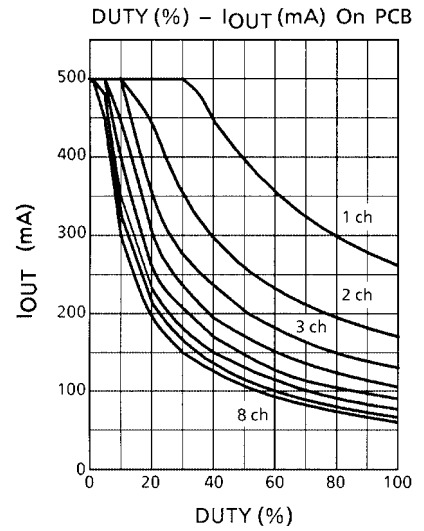
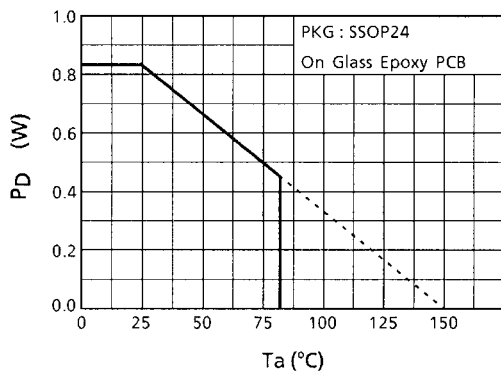

Fig.8 DUTY - I_{OUT}
 ($T_{opr} = 25^{\circ}\text{C}$)



SSOP24 Power dissipation

Fig.9 $P_D - T_a$



PACKAGE DIMENSIONS

SSOP24-P-300-1.00

Unit: mm

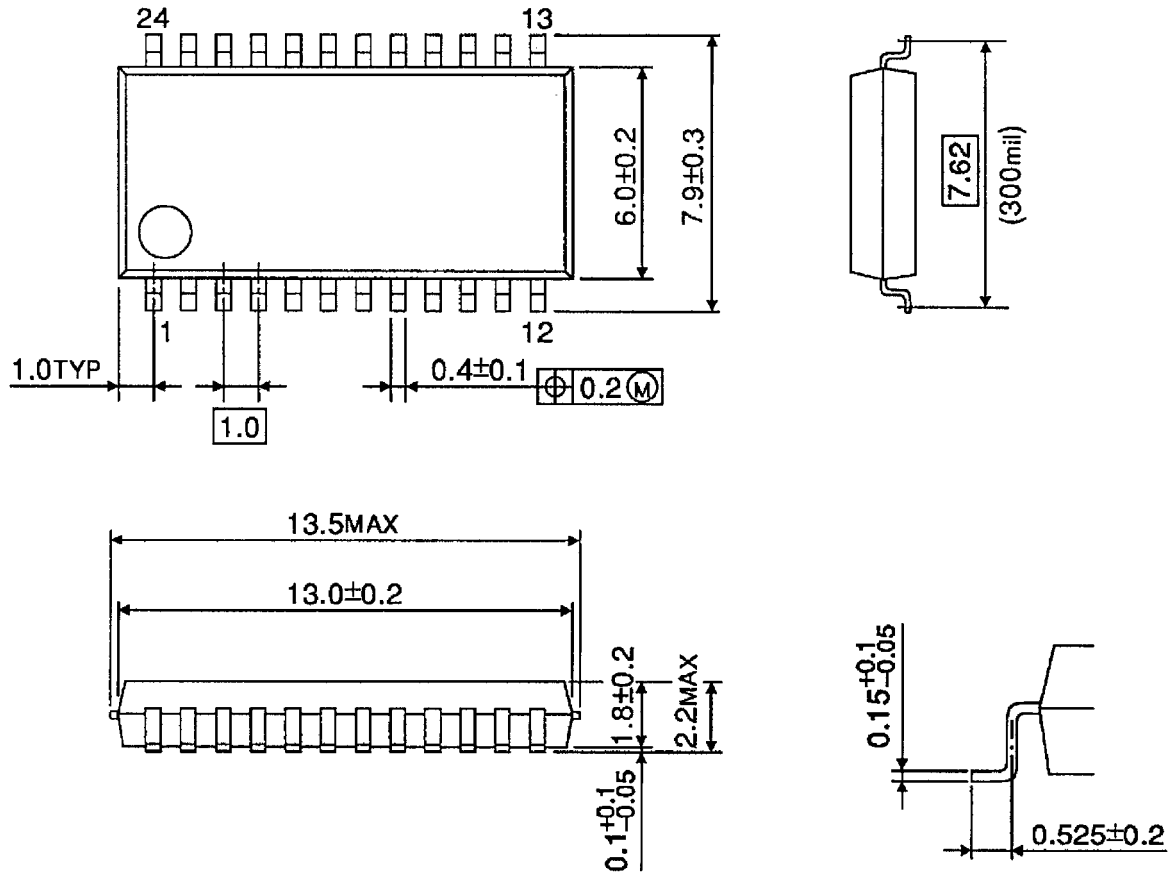

Weight: 0.32 g (Typ.)

RESTRICTIONS ON PRODUCT USE

000707EBA

- TOSHIBA is continually working to improve the quality and reliability of its products. Nevertheless, semiconductor devices in general can malfunction or fail due to their inherent electrical sensitivity and vulnerability to physical stress. It is the responsibility of the buyer, when utilizing TOSHIBA products, to comply with the standards of safety in making a safe design for the entire system, and to avoid situations in which a malfunction or failure of such TOSHIBA products could cause loss of human life, bodily injury or damage to property.
In developing your designs, please ensure that TOSHIBA products are used within specified operating ranges as set forth in the most recent TOSHIBA products specifications. Also, please keep in mind the precautions and conditions set forth in the "Handling Guide for Semiconductor Devices," or "TOSHIBA Semiconductor Reliability Handbook" etc..
- The TOSHIBA products listed in this document are intended for usage in general electronics applications (computer, personal equipment, office equipment, measuring equipment, industrial robotics, domestic appliances, etc.). These TOSHIBA products are neither intended nor warranted for usage in equipment that requires extraordinarily high quality and/or reliability or a malfunction or failure of which may cause loss of human life or bodily injury ("Unintended Usage"). Unintended Usage include atomic energy control instruments, airplane or spaceship instruments, transportation instruments, traffic signal instruments, combustion control instruments, medical instruments, all types of safety devices, etc.. Unintended Usage of TOSHIBA products listed in this document shall be made at the customer's own risk.
- The products described in this document are subject to the foreign exchange and foreign trade laws.
- The information contained herein is presented only as a guide for the applications of our products. No responsibility is assumed by TOSHIBA CORPORATION for any infringements of intellectual property or other rights of the third parties which may result from its use. No license is granted by implication or otherwise under any intellectual property or other rights of TOSHIBA CORPORATION or others.
- The information contained herein is subject to change without notice.