

SINGLE CHANNEL MOBILE PWM CONTROLLER WITH DYNAMIC VOLTAGE ADJUSTMENT

 PRODUCTION DATA SHEET **Pb Free Product**

DESCRIPTION

The NX2147 controller IC is a step down switching controller with ability to dynamically adjust the output voltage designed for applications such as Graphic Processor Core voltage in Notebook PC products. It allows this by adjusting the reference input of the PWM comparator as oppose to the traditional method of feedback adjustment. This device has three mode of operations; a) Constant ON Time Synchronous Mode, b) Non Synchronous PFM mode or c) Ultrasonic PFM mode of operation. When selected in Non Synchronous mode, the device automatically disables the synchronous MOSFET in order to improve efficiency at light load. This device provides excellent dynamic response and nearly constant frequency for operation from 4.5V to 24V of input voltage operation. Other features of the device are; internal logic level signal MOSFETs for output dynamic voltage adjustment, internal boost schottky diode, less than 1uA VIN shutdown current, adjustable current limiting using lower MOSFET Rds-On and feedback UVLO followed by latchdown, overvoltage protection, internal digital soft start and soft stop shutdown using and internal 20 ohm MOSFET pull down.

FEATURES

- Output voltage can be dynamically changed
- Internal Boost Schottky Diode
- Ultrasonic mode operation available
- Bus voltage operation from 4.5V to 24V
- Less than 1uA VIN shutdown current with Enable low
- Excellent dynamic response with constant on time control
- Selectable between Synchronous CCM mode and diode emulation mode to improve efficiency at light load
- Programmable switching frequency
- Current limit and FB UVLO with latch off
- Over voltage protection with latch off
- Pb-free and RoHS compliant

APPLICATIONS

- Notebook PCs and Desknotes
- Tablet PCs/Slates
- On board DC to DC such as 12V to 3.3V, 2.5V or 1.8V
- Hand-held portable instruments

TYPICAL APPLICATION

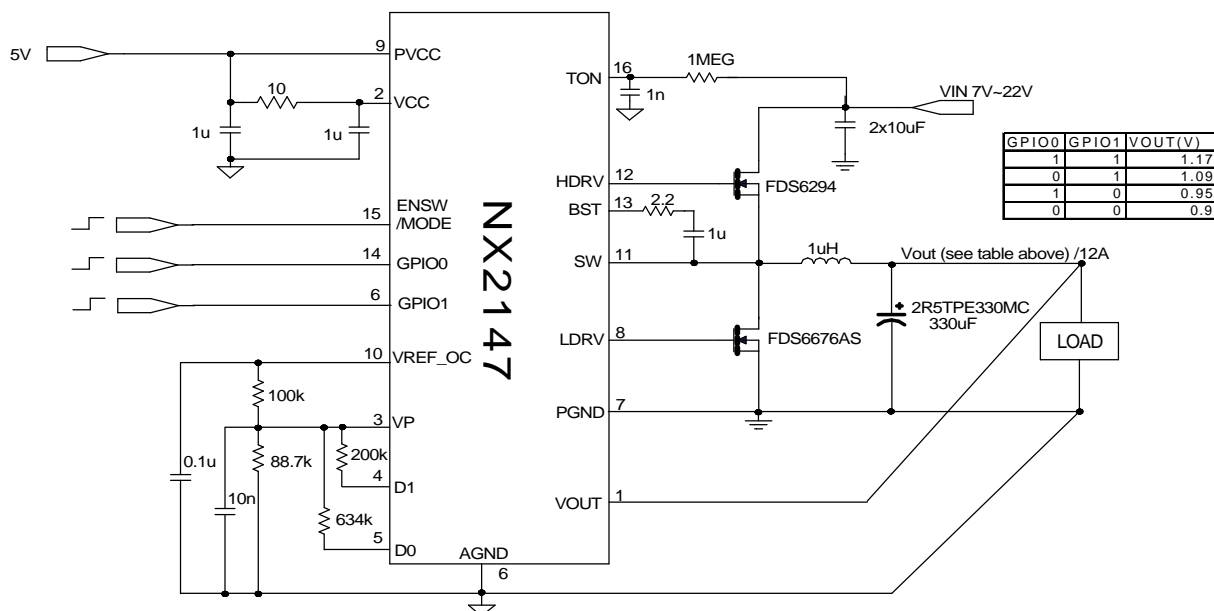

Figure1 - Typical application of NX2147

ORDERING INFORMATION

Device	Temperature	Package	Pb-Free
NX2147CMTR	-10°C to 100°C	3X3 MLPQ-16L	Yes

ABSOLUTE MAXIMUM RATINGS

VCC,PVCC to GND & BST to SW voltage	-0.3V to 6.5V
VIN,TON to GND	-0.3V to 28V
HDRV to SW Voltage	-0.3V to 6.5V
SW to GND	-2V to 30V
All other pins	VCC+0.3V
Storage Temperature Range	-65°C to 150°C
Operating Junction Temperature Range	-40°C to 150°C
ESD Susceptibility	2kV

CAUTION: Stresses above those listed in "ABSOLUTE MAXIMUM RATINGS", may cause permanent damage to the device. This is a stress only rating and operation of the device at these or any other conditions above those indicated in the operational sections of this specification is not implied.

PACKAGE INFORMATION

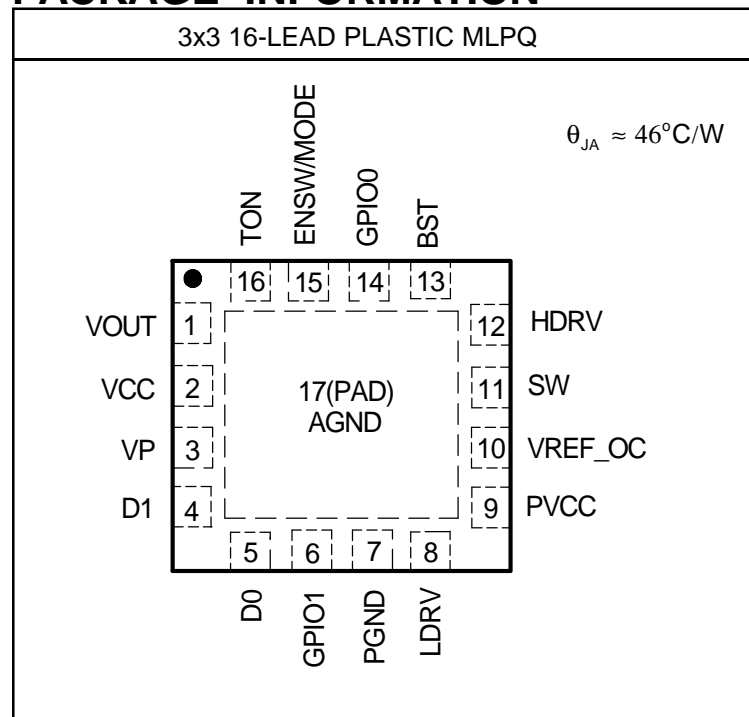

ELECTRICAL SPECIFICATIONS

Unless otherwise specified, these specifications apply over $V_{CC} = 5V$, $V_{IN} = 15V$ and $T_A = 25^{\circ}\text{C}$, unless otherwise specified.

PARAMETER	SYM	Test Condition	Min	TYP	MAX	Units
VIN						
Recommended voltage range			4.5		24	V
Shut down current		ENSW=GND		1		uA
VCC,PVCC Supply						
Input voltage range	V_{CC}		4.5		5.5	V
Operating quiescent current		No switching, ENSW=5V		1.6		mA
Shut down current		ENSW=GND		1		uA

PARAMETER	SYM	Test Condition	Min	TYP	MAX	Units
VCC UVLO Under-voltage Lockout threshold	V _{CC_UVLO}			4.1		V
Falling VCC threshold				3.9		V
ON and OFF time TON operating current		V _{IN} =15V, R _{ton} =1Mohm		15		uA
ON -time		V _{IN} =9V, V _P =V _{OUT} =0.75V, R _{ton} =499k		390		ns
Minimum off time			380	590	800	ns
VREF_OC voltage VREF_OC voltage			2.475	2.5	2.525	V
Line regulation		VCC from 4 to 5.5	-2		2	%
OUTPUT voltage Output range			0		5.5	V
VOUT shut down discharge resistance		ENSW/MODE=GND		30		ohm
Soft start time				1.5		ms
GPIO threshold Output high			2		5	V
Output low			0		0.8	V
DO,D1 internal pull down MOSFET impedance				13		mohm
SW zero cross comparator Offset voltage				5		mV
High Side Driver (CL=3300pF) Output Impedance , Sourcing Current	R _{source} (Hdrv)	I=200mA		1.5		ohm
Output Impedance , Sinking Current	R _{sink} (Hdrv)	I=200mA		1.5		ohm
Rise Time	T _{Hdrv} (Rise)	10% to 90%		50		ns
Fall Time	T _{Hdrv} (Fall)	90% to 10%		50		ns
Deadband Time	T _{dead} (L to H)	Ldrv going Low to Hdrv going High, 10% to 10%		30		ns
Low Side Driver (CL=3300pF) Output Impedance, Sourcing Current	R _{source} (Ldrv)	I=200mA		1.5		ohm
Output Impedance, Sinking Current	R _{sink} (Ldrv)	I=200mA		0.5		ohm
Rise Time	T _{Ldrv} (Rise)	10% to 90%		50		ns
Fall Time	T _{Ldrv} (Fall)	90% to 10%		50		ns
Deadband Time	T _{dead} (H to L)	SW going Low to Ldrv going High, 10% to 10%		10		ns
Over temperature Threshold				155		°C
Hysteresis				15		°C

PARAMETER	SYM	Test Condition	Min	TYP	MAX	Units
ENSW/MODE threshold and bias current						
PFM/Non Synchronous Mode			80% VCC		VCC+0 .3V	V
Ultrasonic Mode			60% VCC		80% VCC	V
Synchronous Mode		Leave it open or use limits in spec	2		60% VCC	V
Shutdown mode			0		0.8	V
Input bias current		ENSW/MODE=VCC		1		uA
		ENSW/MODE=GND		-1		uA
Under voltage protection						
Under voltage trigger point				70		%VP
Over voltage protection						
Over voltage tripp point				125		%VP
Internal Schottky Diode						
Forward voltage drop		forward current=50mA		500		mV

PIN DESCRIPTIONS

PIN NUMBER	PIN SYMBOL	PIN DESCRIPTION
1	VOUT	This pin is directly connected to the output of the switching regulator and senses the VOUT voltage. An internal MOSFET with 20ohms rdson discharges the output during turn off.
2	VCC	This pin supplies the internal 5V bias circuit. A 1uF X7R ceramic capacitor is placed as close as possible to this pin and ground pin.
3	VP	This pin is connected via resistor divider to VREF_OC pin to set the output DC voltage from 0.5V to VREF 2.5V.
4	D1	This pin is a drain of an internal signal MOSFET. When it is connected via resistor to the VP pin, and the GPIO0 pin is set low, it reduces the VP voltage by paralleling this resistor to the fixed resistor from VP to GND.
5	D0	This pin is a drain of an internal signal MOSFET. When it is connected via resistor to the VP pin, and the GPIO_1 pin is set low, it reduces the VP voltage by paralleling this resistor to the fixed resistor from VP to GND.
6	GPIO1	A logic level input signal that controls the D1 pin. A low signal turns the internal D1 MOSFET on and a High turns it off.
7	PGND	Power ground.
8	LDRV	Low side gate driver output.
9	PVCC	Provide the voltage supply to the lower MOSFET drivers. Place a high frequency decoupling capacitor 1uF X5R to this pin.
10	VREF_OC	Reference output voltage. A resistor divider from this pin to VP pin sets the output voltage. The total resistance from this pin to GND also sets the OCP threshold voltage. Note that when GPIO0 and GPIO1 pins are high the reference divider is at its highest voltage. The nominal voltage of Vref is 2.5V.
11	SW	This pin is connected to source of high side FETs and provide return path for the high side driver. It is also the input of zero current sensing comparator.
12	HDRV	High side gate driver output.
13	BST	This pin supplies voltage to high side FET driver. A high freq 1uF X7R ceramic capacitor and 2.2ohm resistor in series are recommended to be placed as close as possible to and connected to this pin and SW pin.
14	GPIO0	A logic level input signal that controls the D0 pin. A low signal turns the internal D0 MOSFET on and a High turns it off.
15	ENSW/ MODE	Switching converter enable input. Connect to VCC for PFM/Non synchronous mode, connected to an external resistor divider equals to 70%VCC for ultrasonic, connected to GND for shutdown mode, floating or connected to 2V for the synchronous mode.
16	TON	VIN sensing input. A resistor connects from this pin to VIN will set the frequency. A 1nF capacitor from this pin to GND is recommended to ensure the proper operation.
17	PAD	Analog ground.

BLOCK DIAGRAM

Figure 2 - Simplified block diagram of the NX2147

TYPICAL APPLICATION

(VIN=7V to 22V, VOUT=1.09V/12A)

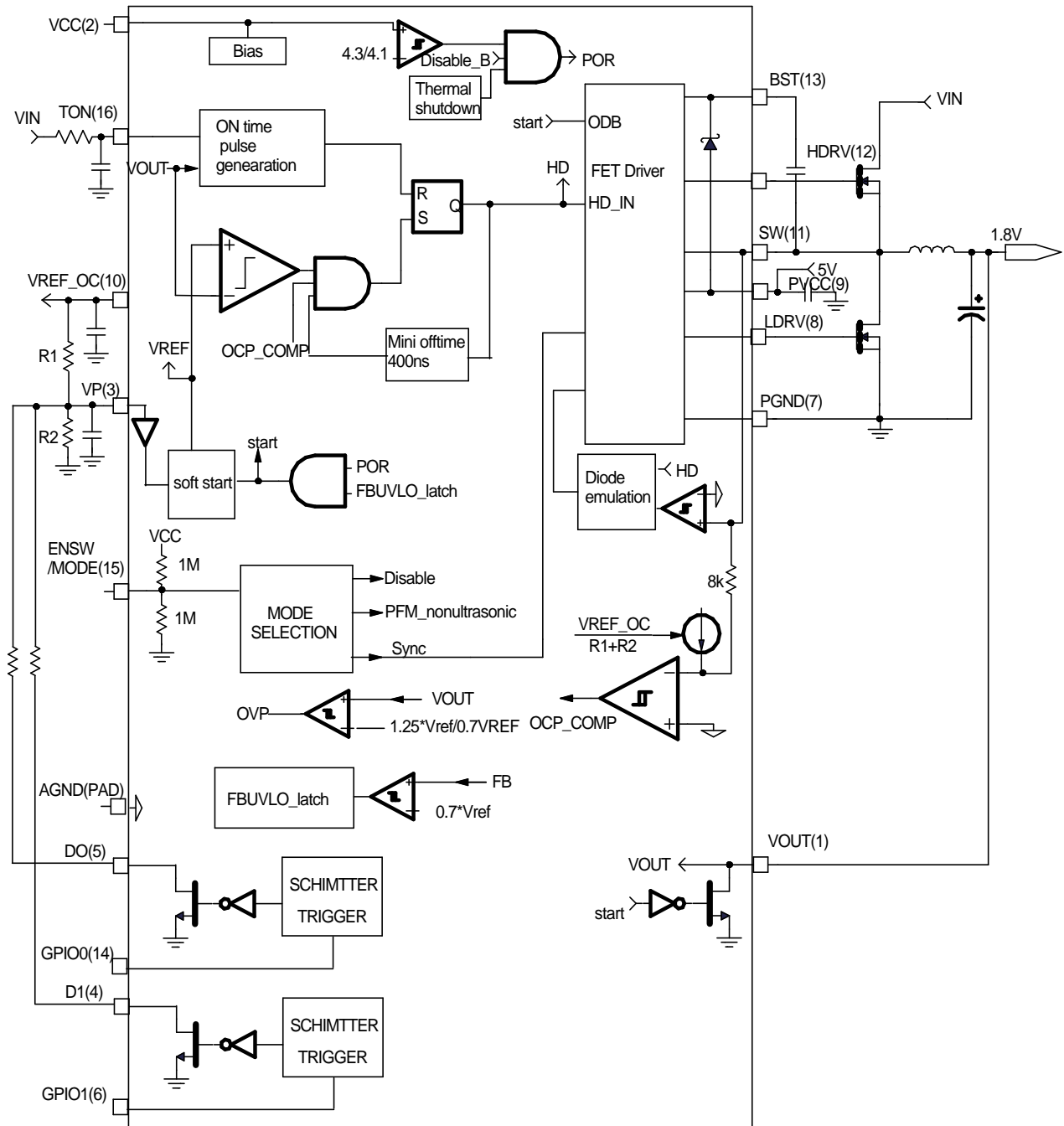
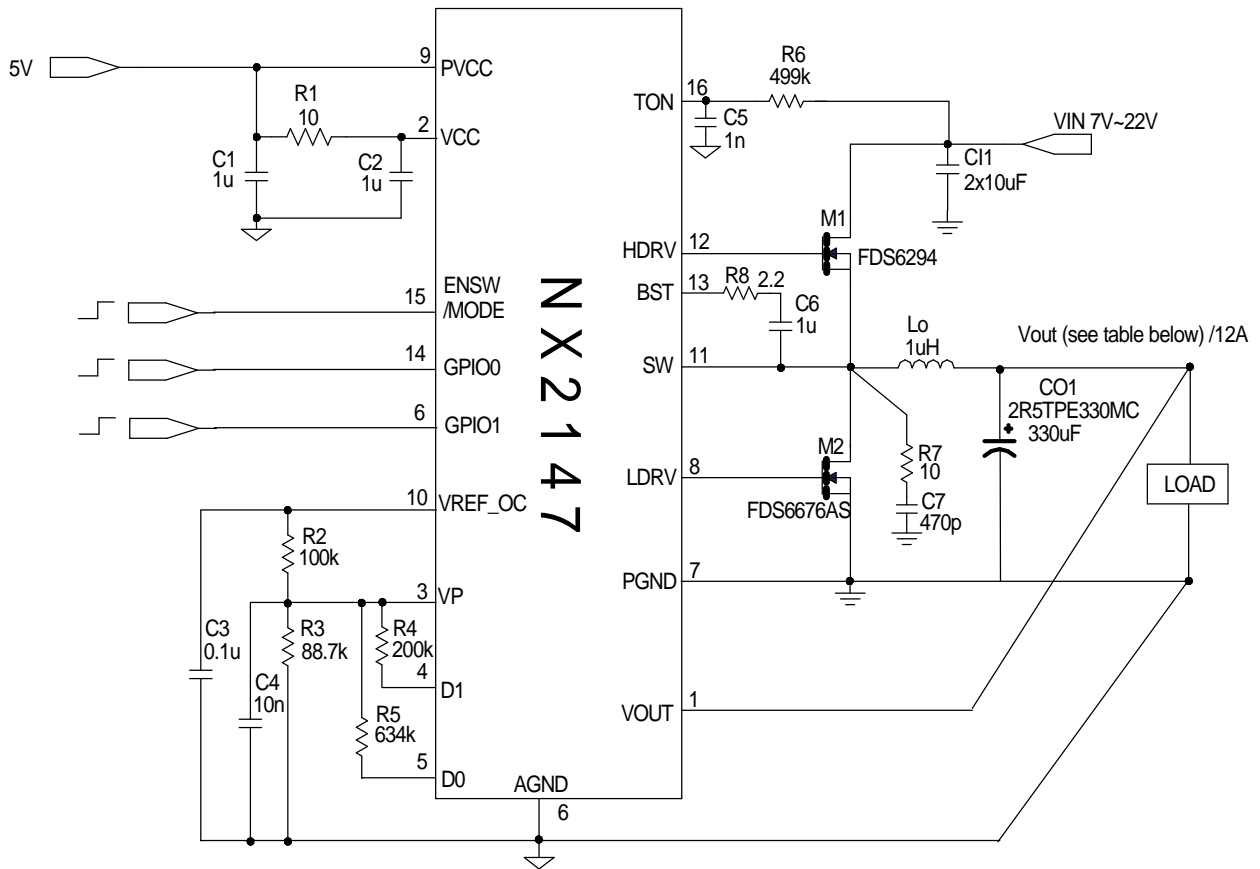

VOUT TABLE:

GPIO0	GPIO1	VOUT(V)
1	1	1.17
0	1	1.09
1	0	0.95
0	0	0.9

Figure 3 - Demo board schematic

Bill of Materials

Item	Quantity	Reference	Value	Manufacture
1	2	CI1	10uF/X5R/25V	
2	1	CO1	2R5TPE330MC	SANYO
3	2	C1,C2	1uF	
4	2	C3,C6	0.1uF	
5	1	C4	10nF	
6	1	C5	1nF	
7	1	C7	470p	
8	1	Lo	RL-8250-1.4-1R0M	RENCO
9	1	M1	FDS6294	FAIRCHILD
10	1	M2	FDS6676AS	FAIRCHILD
11	1	R1	10	
12	1	R2	100k	
13	1	R3	88.7k	
14	1	R4	200k	
15	1	R5	634k	
16	1	R6	499k	
17	1	R7	10	
18	1	R8	2.2	
19	1	U1	NX2147	NEXSEM INC.

Demoboard waveforms

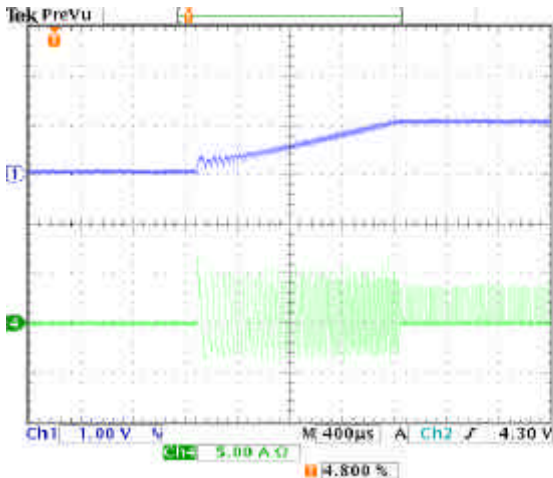

Fig.4 Start up(CH1 VOUT 1V/DIV, CH4 Output current 5A/DIV)

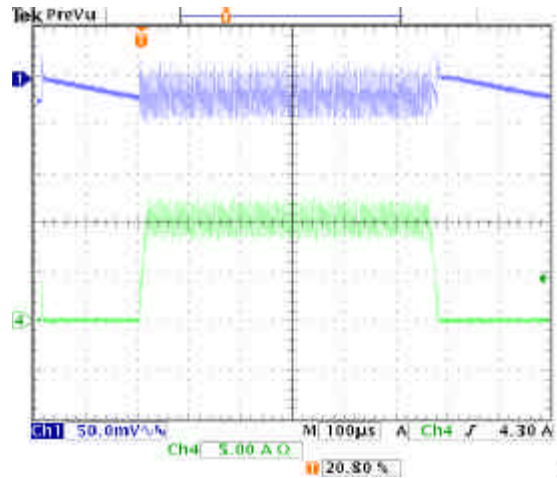

Fig.5 10A step response(CH1 VOUT AC 50mV/DIV, CH4 Output current 5A/DIV)

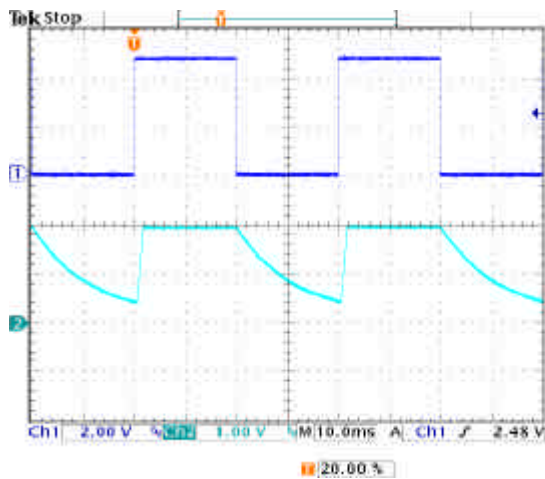

Fig.6 Soft turn off(CH1 ENSW 2V/DIV, CH2 VOUT 0.5V/DIV)

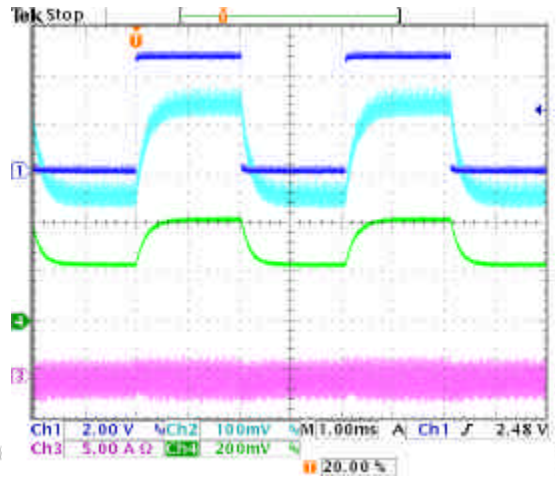

Fig.7 D0=0, D1 from low to high(CH1 D0 2V/DIV, CH2 VOUT 0.1V/DIV 0.8V OFFSET, CH3 INDUCTOR CURRENT 5A/DIV, CH4 VP 0.1V/DIV 0.8V OFFSET)

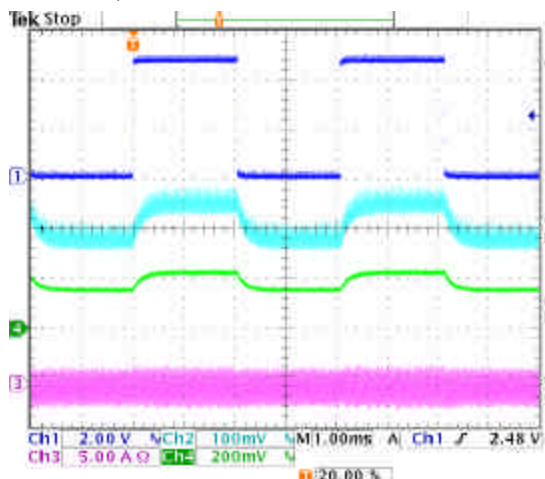

Fig.8 D1=0, D0 from low to high(CH1 D0 2V/DIV, CH2 VOUT 0.1V/DIV 0.8V OFFSET, CH3 INDUCTOR CURRENT 5A/DIV, CH4 VP 0.1V/DIV 0.8V OFFSET)

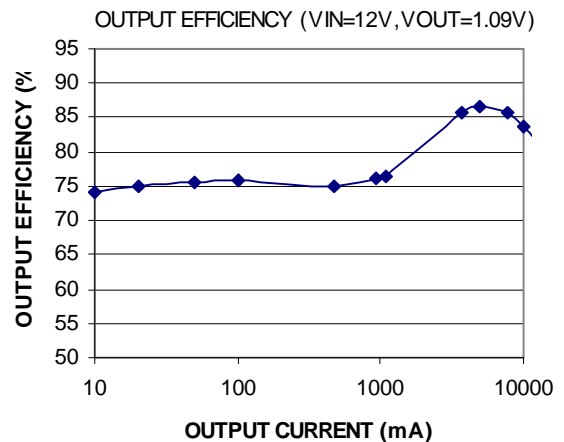
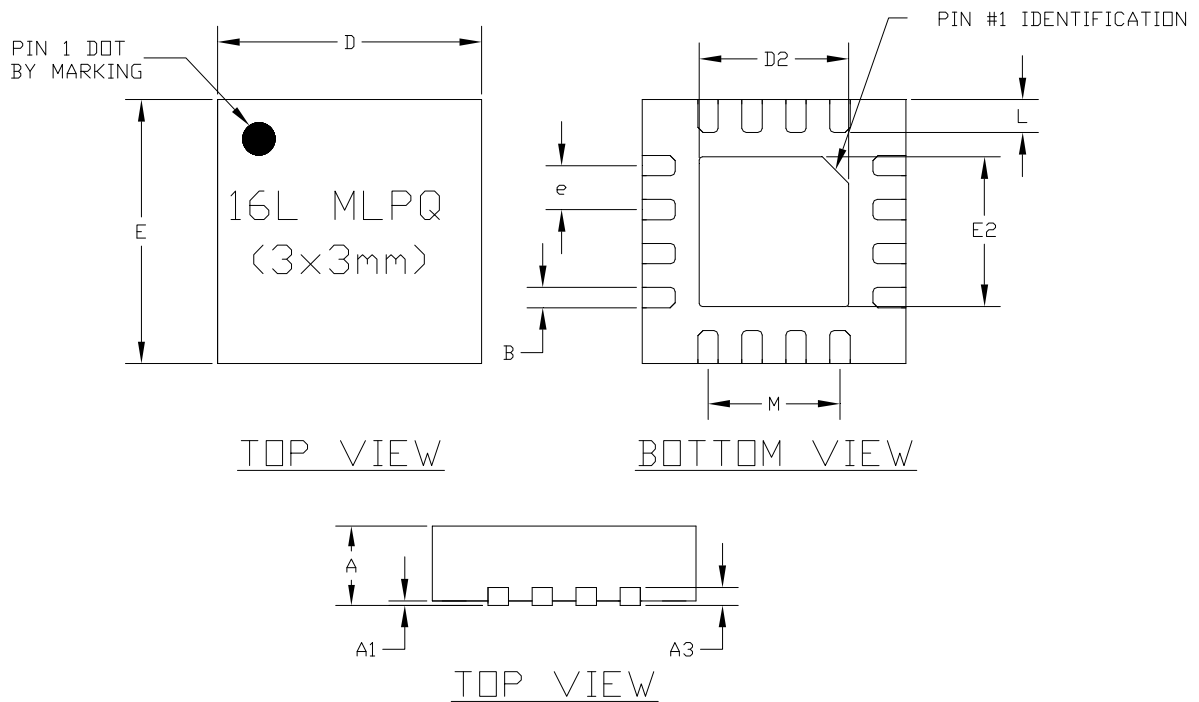

Fig.9 Output efficiency

MLPQ 16 PIN 3 x 3 PACKAGE OUTLINE DIMENSIONS

SYMBOL NAME	Dimensions In Millimeters		Dimensions In Inches	
	MIN	MAX	MIN	MAX
A	0.700	0.800	0.028	0.031
A1	0.000	0.050	0.000	0.002
A3	0.203REF		0.008REF	
B	0.180	0.300	0.007	0.012
D	2.950	3.050	0.116	0.120
D2	1.600	1.750	0.063	0.069
E	2.950	3.050	0.116	0.120
E2	1.600	1.750	0.063	0.069
e	0.50BSC		0.50BSC	
L	0.325	0.450	0.013	0.018
M	1.5REF		0.059REF	

