

LED Drivers for LCD Backlights

White Backlight LED Drivers for Small to Medium LCD Panels (Switching Regulator Type)



BD6077GUT

No.11040EAT41

●Description

The BD6077GUT is a white LED driver IC with synchronous rectification that can drive up to 3LEDs.

With synchronous rectification (no external schottky diode required) and small package, they can save mount space.

And the brightness of LED can be adjusted by using PWM pulse on EN pin.

●Features

- 1) Synchronous rectification Boost DC/DC converter
- 2) No external schottky diode required
- 3) Driving 3 series white LEDs
- 4) Over voltage protection
- 5) Protect open and short output
- 6) Thermal shut down
- 7) Brightness adjustment by external PWM pulse
- 8) Small and Thin CSP package in 8pins

●Applications

White LED Backlight

Torchlight and easy flash for camera of mobile phone

●Absolute maximum ratings (Ta=25°C)

Parameter	Symbol	Ratings	Unit	Condition
Maximum applied voltage 1	VMAX1	7 * ¹	V	Vin, EN, VFB, TEST
Maximum applied voltage 2	VMAX2	20 * ¹	V	SW, Vout
Power dissipation	Pd	750 * ²	mW	
Operating temperature range	Topr	-30~+85	°C	
Storage temperature range	Tstg	-55~+150	°C	

*¹ These value are based on GND and GNDA pins.

*² 50mm×58mm×1.75mm At glass epoxy board mounting. When it's used by more than Ta=25 °C, it's reduced by 6.0mW/°C.

●Operating conditions (Ta=25°C)

Parameter	Symbol	Ratings			Unit	Condition
		Min.	Typ.	Max.		
Power supply voltage	Vin	2.7	3.6	5.5	V	

●Electrical characteristics

Unless otherwise specified Ta = -30°C~+85°C, Vin=3.1~5.5V

Parameter	Symbol	Limits			Unit	Condition
		Min.	Typ.	Max.		
[EN terminal]						
EN threshold voltage (Low)	VthL	-	-	0.4	V	
EN threshold voltage (High)	VthH	1.4	-	-	V	
EN terminal input current	Iin	-	18.3	30.0	μA	EN=5.5V
EN terminal output current	Iout	-2.0	-0.1	-	μA	EN=0
[Switching regulator]						
Quiescent Current	Iq	-	0.1	2.0	μA	EN=TEST=VFB=0V,SW=open
Current Consumption	Idd	-	1.0	1.5	mA	EN=1.4V,TEST=0V,VFB=1.0V,SW=open
Feedback voltage	Vfb	0.47	0.50	0.53	V	EN=1.4V,TEST=0V
Inductor current limit	Icoil	210	310	410	mA	EN=1.2V, TEST=2.9V, Vin=3.6V,VOUT=9V (*1)
SW saturation voltage	Vsat	-	0.245	0.345	V	Isw=200mA, Vin=3.6V
SW on resistance P	Ronp	-	5.4	7.2	Ω	Isw=200mA, Vout=10V
Switching frequency	fSW	0.8	1.0	1.2	MHz	EN=1.4V,TEST=0V,VFB=0V, VOUT=10V,SW=open
Duty cycle limit	Duty	82.7	95.0	-	%	EN=1.4V,TEST=0V,VFB=0V, VOUT=10V,SW=open
Over voltage limit	Ovl	14.0	14.5	15.0	V	EN=1.4V,TEST=0V,VFB=0V, SW=open

1 This parameter is tested with DC measurement.

● Test circuit

*Test circuit A (for Inductor current limit, Feedback voltage.)

Procedure

~Inducton current limit~

1. Start to increase Iout from 0mA gradually.
2. You will find that Vout will start to go down and the duty will be decreased.
3. Then, you can measure the coil current as "inductor current limit"

~VFB voltage~

1. Supply 0mA to Iout
2. Then, you can measure the VFB voltage as "Feedback voltage".

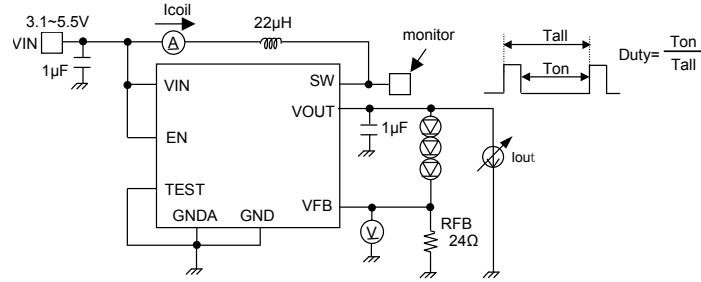

Fig.1 Test Circuit A

*Test circuit B (for Over voltage limit, Duty cycle limit, Switching frequency)

Procedure

~Over voltage limit~

1. Start to increase VOUT from 12V to 16V
2. You will find frequency change from around 1MHz to 0Hz
3. Then, you can measur the VOUT voltage as "Over Voltage limit"

~Duty cycle limit, Switching frequency ~

1. Supply 9V to VOUT terminal
2. Then, you can measure the duty as "Duty cycle limit" and the frequency and "Switching frequency".

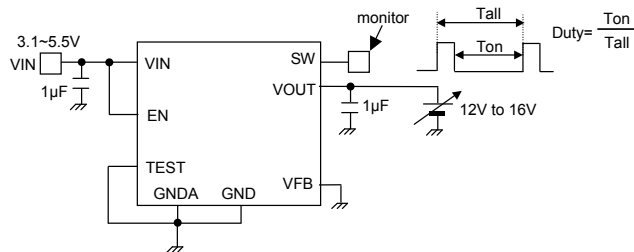

Fig.2 Test Circuit B

*TEST circuit C

(for Quiescent current, current consumption, EN Terminal input/output current, EN threshold voltage(Low/High))

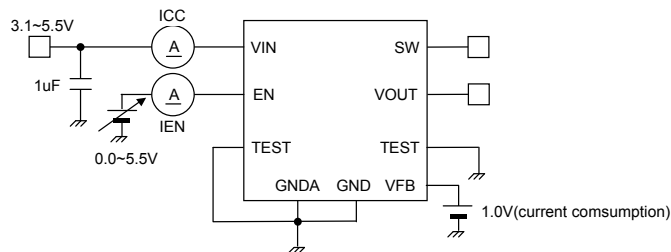

Fig.3 Test Circuit C

●Electrical characteristic curves (Reference data)

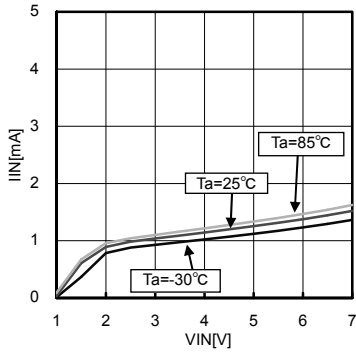

Fig.4 Current consumption vs. Power supply voltage

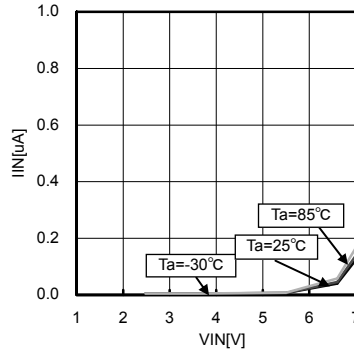

Fig.5 Quiescent current vs. Power supply voltage

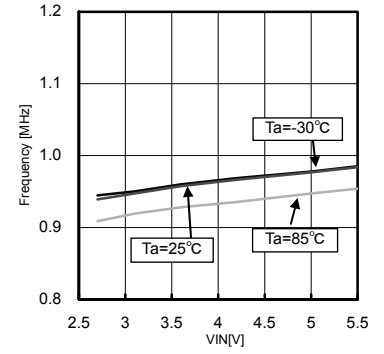

Fig.6 Oscillation frequency vs. Power supply voltage

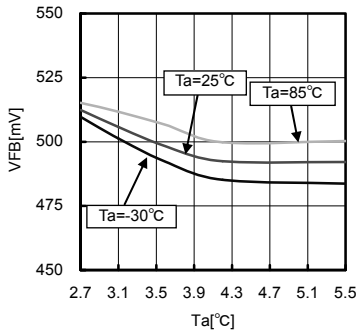

Fig.7 Feedback voltage vs. Power supply voltage

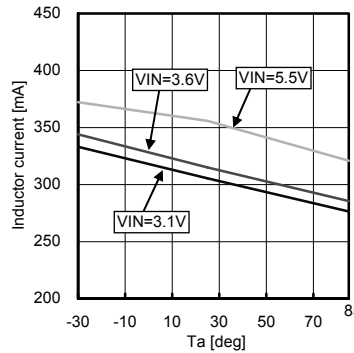

Fig.8 Inductor current limit vs. Temperature

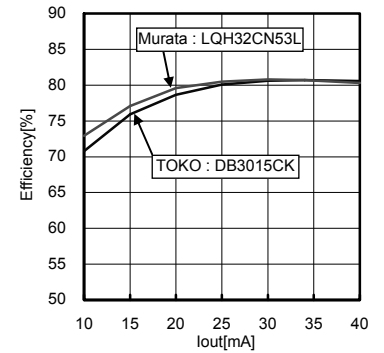

Fig.9 Efficiency vs. LED current (4LED=VOUT14V)

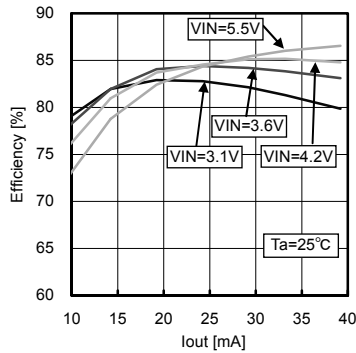

Fig.10 Efficiency vs. LED current (3LED=VOUT10.5V) coil : TOKO DB3015CK

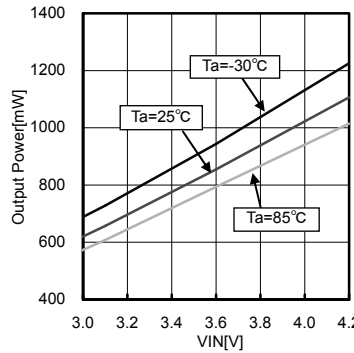

Fig.11 Output power vs. Power supply voltage coil : TOKO DB3015CK

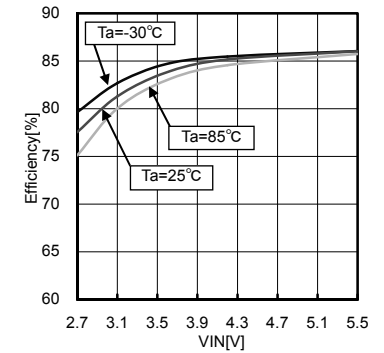

Fig.12 Efficiency vs. Power supply voltage (Load=34mA) coil : TOKO DB3015CK

●Electrical characteristic curves (Reference data) – Continued

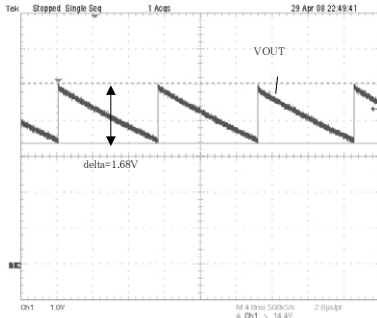

Fig.13 LED Open output voltage

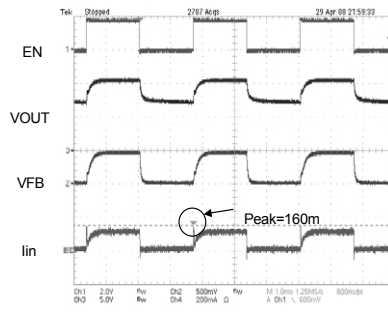

Fig.14 LED brightness adjustment

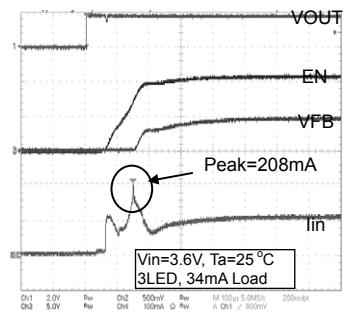

Fig.15 Soft Start

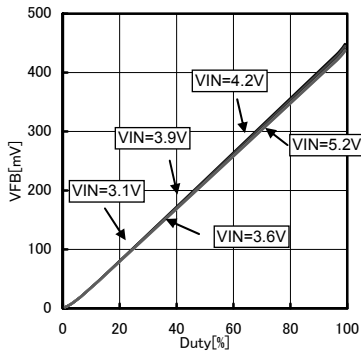

Fig.16 LED brightness adjustment for PWM control

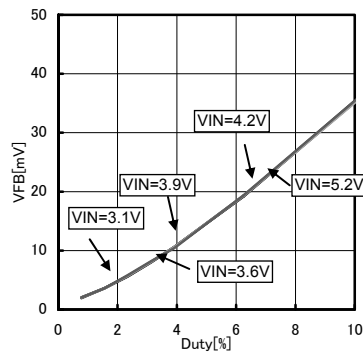

Fig.17 LED brightness adjustment for PWM control (Expansion)

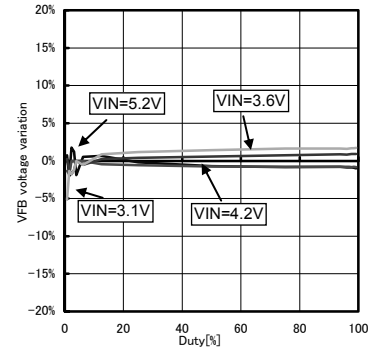

Fig.18 LED brightness variation for PWM control (comparison of VFB at VIN=3.9V)

●Block diagram and pin configuration

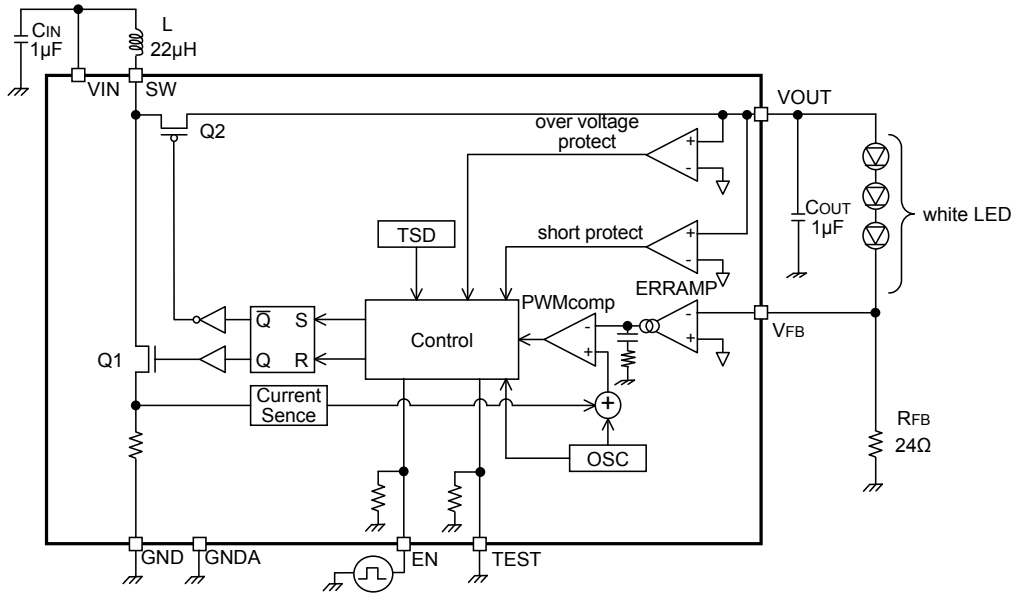

Fig.19 Block diagram and recommended circuit diagram

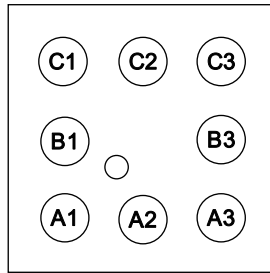

Fig.20 Pin location diagram VCSP60N1(8 pin)

●Pin assignment table

PIN Name	In/Out	Ball number	Function
GNDA	-	A1	Analog GND
EN	In	A2	Enable control (pull down by inner resistor)
TEST	In	A3	TEST input (pull down by inner resistor)
VIN	In	B1	Power supply input
VFB	In	B3	Feedback voltage input
VOUT	Out	C1	Boost output
SW	In	C2	Switching terminal
GND	-	C3	Power GND

●Operation

BD6077GUT is PWM current mode DC/DC converter with fixed frequency. It adopts synchronous rectification architecture. The feature of the PWM current mode is that input is the combination of error components from the error amplifier, and a current sense signal that controls the inductor current into Slope waveform for sub harmonic oscillation prevention. This output controls Q1 and Q2 via the RS latch. Timing of Q1 and Q2 is precisely adjusted so that they will not turn ON at the same time, thus putting them into non-overlapped relation. In the period when Q1 is ON, energy is accumulated in the external inductor, and in the period when Q1 is OFF, energy is transferred to the capacitor of VOUT via Q2. Further more, BD6077GUT has many safety functions, and their detection signals stop switching operation at once.

●Functional descriptions

1) Soft start and off status

BD6077GUT has soft start function and off status function.

The soft start function and the off status function prevent large current from flowing to the IC via coil.

The soft start function prevents rush current when turning on and the off status function prevents invalid current when turning off.

• Soft start

When V_{OUT} is smaller than V_{short} , to decrease charge current PMOS is set to off by PMOS Startup Control (in Term "I"). V_{short} means "VOUT short detect voltage". After V_{OUT} is bigger than V_{short} , PMOS is turned on and start switching. In term "II" ($V_{short} < V_{OUT} < V_{IN}$), status of Current Limiter is "soft mode". So "A" voltage is restricted and "D" duty is kept low. Therefore V_{OUT} voltage goes up slowly and coil current is restricted. In term III ($V_{OUT} > V_{IN}$), status of Current Limiter is "normal mode". So "A" voltage goes up suitable voltage, and "D" duty goes up slowly. And then V_{OUT} voltage goes up to required voltage.

Operation	Max current
Current at start	380mA
Current at PWM	270mA

LED $V_F=3.2V@20mA$,
 $C_{OUT} : 1\mu F@16V X5R$

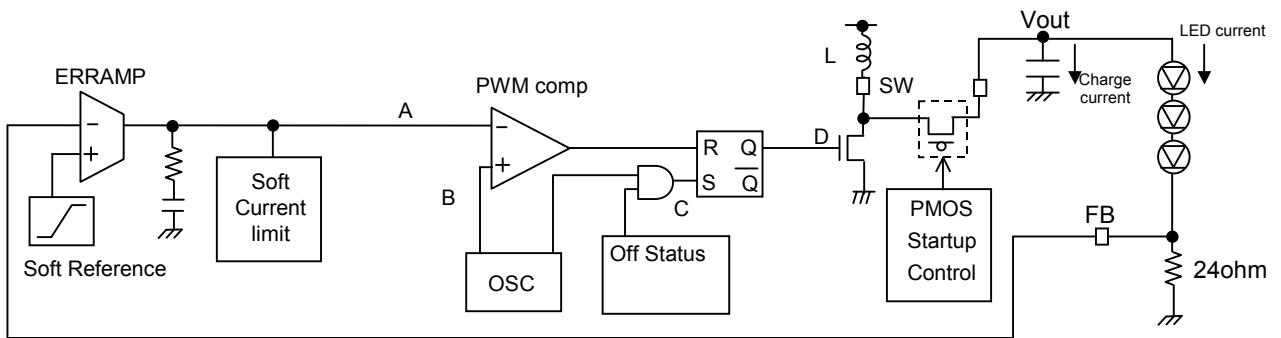

Fig. 21 lock diagram of soft start and off status

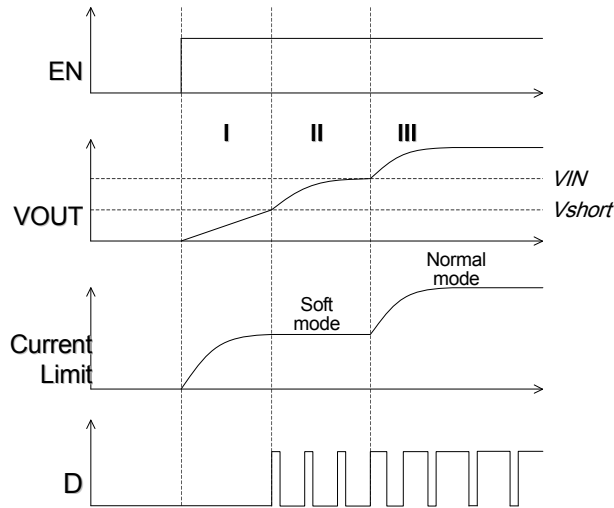

Fig. 22 timing chart

• Off status

The gate voltage of the switching T_r either "H" or "L" at power off depends on the operation conditions at that time. When it is fixed to "H", the switching T_r remains to be ON, and invalid current from the battery is consumed. In order to prevent this, at power off, D is always fixed to L level. So that, it is possible to prevent invalid current at power off.

2) Isolation control

BD6077GUT has isolation control to prevent LED wrong lighting at power off.

The cause of the LED wrong lighting is leak current from VIN to the white LED.

Therefore, when BD6077GUT powered off (EN = L), the isolation control cuts the DC path between SW and Vout, so that, it prevents from leak current from VIN to LED.

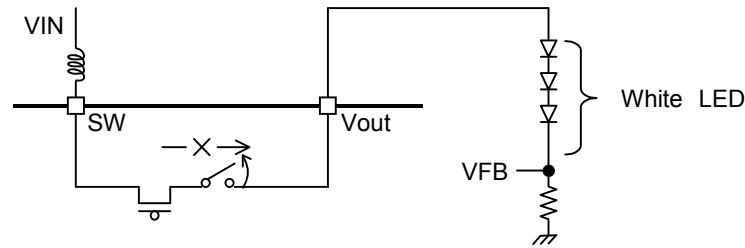

Fig.23 Isolation control

3) Short-circuit protection and over voltage protection

BD6077GUT has short-circuit protection and over voltage protection. These detect the voltage of VOUT, and at error, they stop the output Tr. Details are as shown below.

- Short-circuit protection

In the case of short-circuit of the DC/DC output (VOUT) to GND, the coil or the IC may be destroyed.

Therefore, in a case of error as VOUT becomes 0.7V or lower, the Under Detector shown in the figure works, and turns off the output Tr, and prevents the coil and the IC from being destroyed.

And the IC turns into non operation condition from operation condition, and current does not flow to the coil (0mA).

- Over voltage protection

In a case of error as the IC and the LED being cut off, over voltage causes the SW terminal and the VOUT terminal exceed the absolute maximum ratings, and may destroy the IC. Therefore, when VOUT becomes 14.5V or higher, the over voltage limits works, and turns off the output Tr, and prevents the SW terminal and the VOUT terminal from exceeding the absolute maximum ratings.

At this moment, turns into non operation condition from operation condition, and the output voltage goes down slowly. And, when the output voltage becomes the hysteresis of the over voltage limit or below, the output voltage goes on up to 14.5V once again.

This protection action is shown in Fig.24.

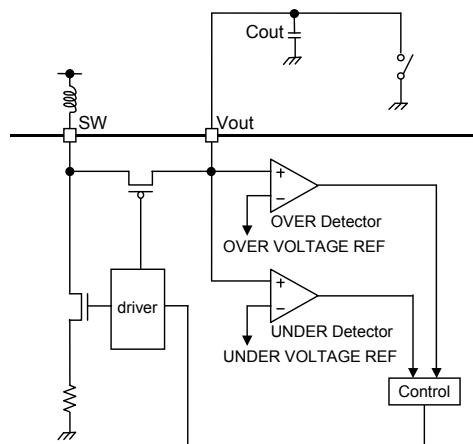

Fig.24 Block diagram of short-circuit protection and over voltage

4) Thermal shut down

BD6077GUT has thermal shut down function.

The thermal shut down works at 175°C or higher, and while holding the setting of EN control from the outside, turns into non operation condition from operation condition. And at 175°C or below, the IC gets back to its normal operation.

●Start control and brightness control

BD6077GUT can control the start conditions by its EN terminal, and power off at 0.4V or below, and power on at 1.4V or higher. And by changing the duty of power on and off by PWM control, the LED brightness can be adjusted.

Two techniques are available for the brightness adjustment. One is PWM adjustment, and the other is analog adjustment.

(1) PWM brightness adjustment is done by giving PWM signal to EN as shown in Fig.25.

The BD6077GUT is powered on/off by the PWM signal. By this method, LED current is controlled from 0 to the maximum current. The average LED current increases with proportion to the duty cycle of PWM signal. While in PWM off-cycle mode, the IC and LED both consume no currents, thus providing a high-efficiency operation. The recommended PWM frequency is 100Hz ~ 300Hz.

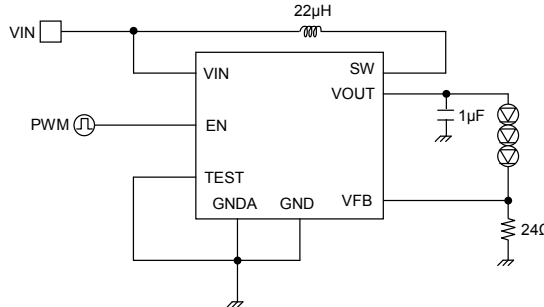

Fig.25 The brightness adjustment example of EN terminal by PWM (fPWM = 100 ~ 300Hz)

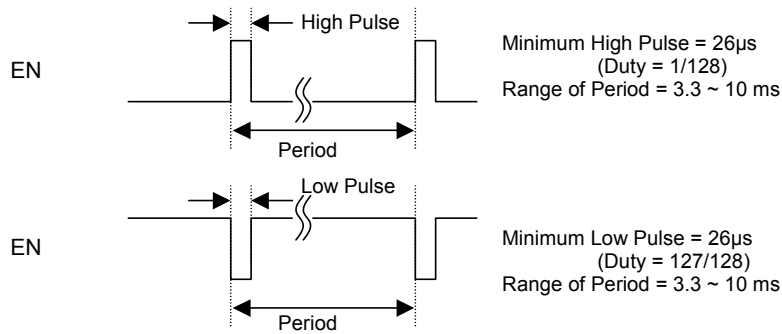

Fig.26 The Rule of PWM signal of EN

●FB characteristic on PWM function

BD6077GUT constantly controls the rising time to decrease the tolerance of the FB voltage at PWM function.

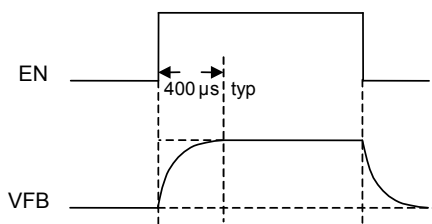

Fig.27 VFB signal at PWM

Compare the value of VFB average voltage at VBAT=4.2V and at VBAT=3.9V in PWM1. (PWM1 = 1/128 Duty)
Difference between VBAT=3.9V and 4.2V VFB voltage is less than 3%.

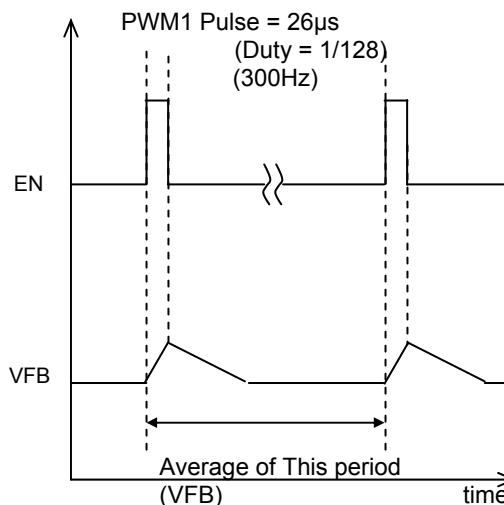

Fig.28 VFB Line Regulation (PWM1)

●V_{BAT} characteristic in Battery charge

Transient during Battery charger is normally +300mV, 1Hz(duty 50%) from a baseline Battery Voltage 3.1 to 2.8V. In this term, it is necessary that V_{OUT} Voltage noise is less than 200mVp-p.

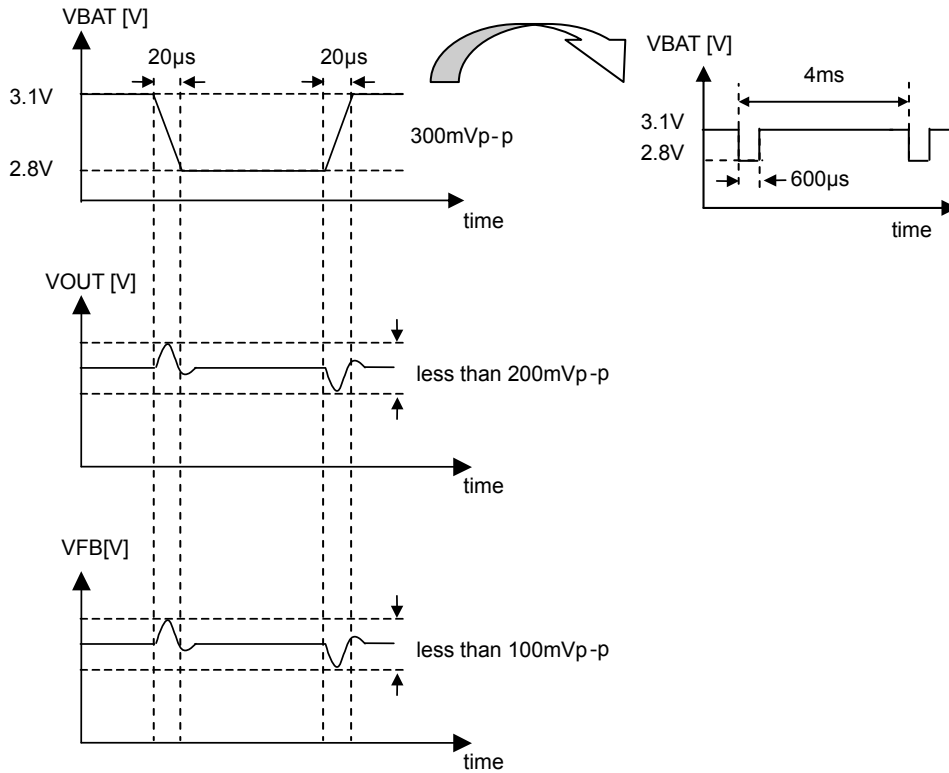

Fig.29 Battery Voltage transient during charger

●Setting range of LED current

LED current is determined by the voltage of V_{FB} and the resistor connected to V_{FB} terminal.

I_{LED} is given as shown below.

$$I_{LED} = V_{FB} / R_{FB}$$

The current in the standard application is as shown below.

$$V_{FB} = 0.5V, R_{FB} = 24\Omega$$

$$I_{LED} = 20.8mA$$

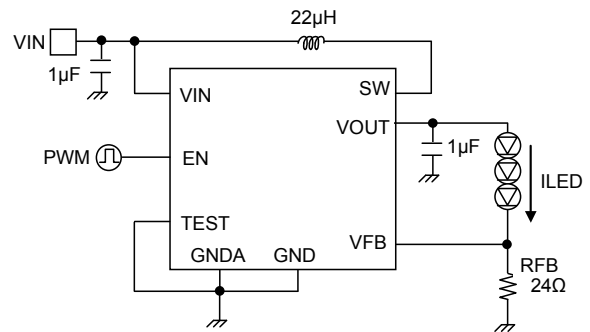

Fig.30 standard application

●Load Regulation Test

The load current from VOUT is set as 15mA(LED)+10mA(key) and +10mA is set to ON/OFF and tested. At that time, VOUT and Ripple of VFB are measured. (VOUT : less than 700mV,VFB : less than 150mV) The difference of VFB voltage in case load is ON and the voltage at the time of being OFF is measured. ($\leq \pm 1\%$)

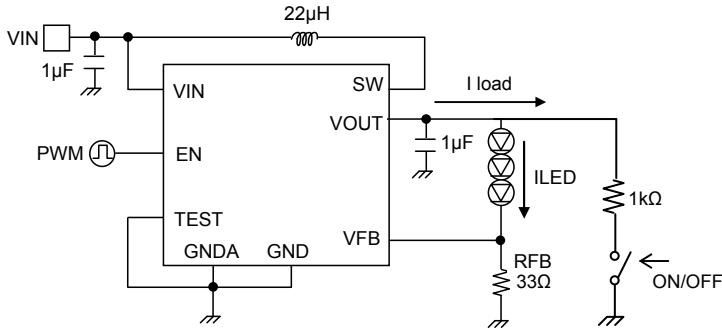

Fig.31 Load Regulation Test circuit

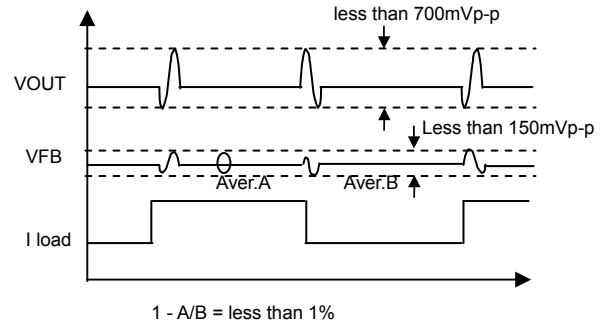

Fig.32 Transient Load Regulation test

The shaded portion in the figure below is the setting range of LED current to become the standard. Depending on coils and white LEDs to be used, however, some ICs may not be used at desired currents. Consequently, for the proper setting of LED current, thoroughly check it for the suitability under use conditions including applicable power supply voltage and temperature.

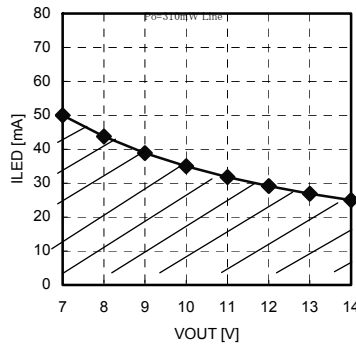

Fig.33 Setting range of LED current

● Selection of external parts

Recommended external parts are listed as below.

When to use other parts than these, select the following equivalent components.

• Coil

Value	Tolerance	Manufacturer	Product number	Size			DCR (Ω)
				Vertical size	Horizontal size	Height	
22 μ H	$\pm 10\%$	MURATA	LQH32CN220K53	2.5	3.2	1.55	0.710
22 μ H	$\pm 20\%$	MURATA	LQH3NPN220MGOL	3.0	3.0	0.9	1.100
22 μ H	$\pm 20\%$	Panasonic	ELLVEG220NN	3.0	3.0	0.9	1.440
22 μ H	$\pm 20\%$	Taiyo Yuden	NR3010T220M	3.0	3.0	1.0	1.236
22 μ H	$\pm 20\%$	TDK	VLS3010T-220MR46	3.0	3.0	1.0	

Please refer to the reference data of p.4 for the change in the efficiency when the coil is changed.

• Capacitor

Value	Manufacturer	Product number	Size			Temperature range
			Vertical size	Horizontal size	Height	
[CIN]						
1 μ F	MURATA	GRM188B11A105K	1.6	0.8	0.8	-25 $^{\circ}$ C~+85 $^{\circ}$ C
[COUT]						
1 μ F	MURATA	GRM188R61C105K	1.6	0.8	0.8	-55 $^{\circ}$ C~+85 $^{\circ}$ C

• Resistor

Value	Tolerance	Manufacturer	Product number	Size		
				Vertical size	Horizontal size	Height
[RFB]						
24 Ω	$\pm 1\%$	ROHM	MCR006YZPF□□□□	0.6	0.3	0.23

Value □□□□

15 Ω 15R0

24 Ω 24R0

33 Ω 33R0

The coil is the component that is most influential to efficiency. Select the coil which direct current resistor (DCR) and current - inductance characteristic are excellent. The BD6077GUT are designed for the inductance value of 22 μ H. Please do not use other inductance value. Select a capacitor of ceramic type with excellent frequency and temperature characteristics. Further, select Capacitor to be used for CIN/COUT with small direct current resistance, and pay much attention to the PCB layout shown in the next page.

●PCB layout

In order to make the most of the performance of this IC, PCB layout is very important.

Please note that characteristics such as efficiency and ripple will likely to change greatly depending on PCB layout.

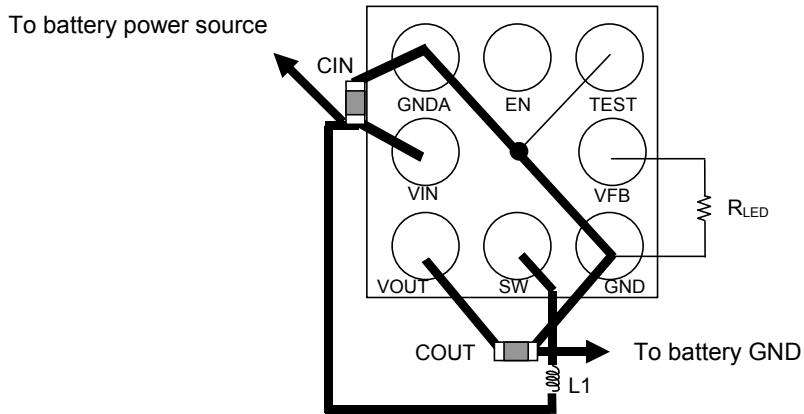
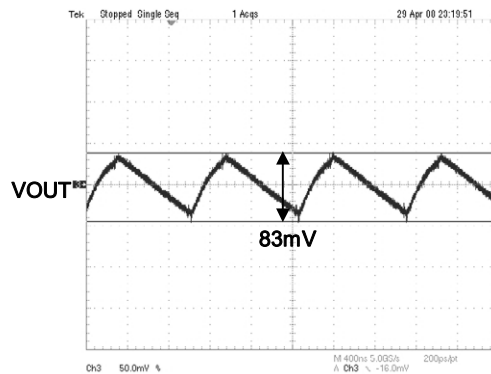

Fig.34 PCB layout

Connect the input bypass capacitor CIN between VIN and GND pin closely, as shown in the upper diagram. Thereby, the input voltage ripple of the IC can be reduced. And, connect the output capacitor COUT between VOUT and GND pin closely. Thereby, the output voltage ripple of the IC can be reduced. Connect the current setting RLED FB pin closely. Connect the GND closely connection side of RLED directly to GND pin. When those pins are not connected directly near the chip, the performance of BD6077GUT shall be influenced and may limit the current drive performance. As for the wire to the inductor, make its resistance component small to reduce electric power consumption and increase the entire efficiency. Please keep away which are subject to be influenced like FB pin in wire connection with SW. The layout pattern in consideration of these is shown in the next page.



(VBAT=3.6V, Ta=25°C, VOUT=10V, 34mA Load)

Fig.35 Output noise

●Recommended PCB layout

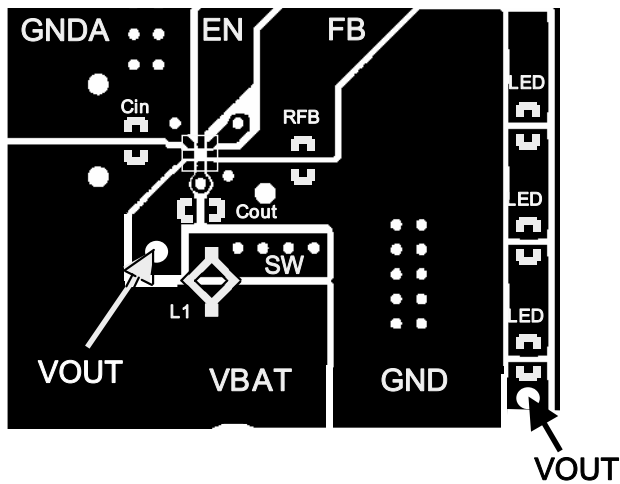

Fig.36 Front surface (TOP VIEW)

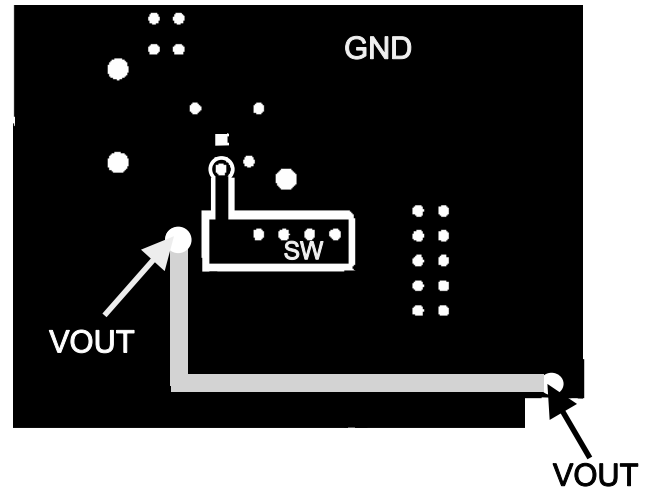

Fig.37 Rear surface (TOP VIEW)

●Attention point for PCB layout

For PCB layout design, the wire of power supply line should be low Impedance, and put bypass capacitor if necessary. Especially the wiring impedance must be low around DC/DC converter.

●About heat loss

For heat design, operate DC/DC converter in the following condition.
(The following temperature is a guaranteed temperature, margin will be needed.)

1. Periphery temperature T_a must be less than 85°C .
2. The loss of IC must be less than dissipation P_d .

●Notes for use

- 1) Absolute Maximum Ratings
An excess in the absolute maximum ratings, such as supply voltage, temperature range of operating conditions, etc., can break down devices, thus making impossible to identify breaking mode such as a short circuit or an open circuit. If any special mode exceeding the absolute maximum ratings is assumed, consideration should be given to take physical safety measures including the use of fuses, etc.
- 2) Operating conditions
These conditions represent a range within which characteristics can be provided approximately as expected. The electrical characteristics are guaranteed under the conditions of each parameter.
- 3) Reverse connection of power supply connector
The reverse connection of power supply connector can break down ICs. Take protective measures against the breakdown due to the reverse connection, such as mounting an external diode between the power supply and the IC's power supply terminal.
- 4) Power supply line
Design PCB pattern to provide low impedance for the wiring between the power supply and the GND lines. In this regard, for the digital block power supply and the analog block power supply, even though these power supplies has the same level of potential, separate the power supply pattern for the digital block from that for the analog block, thus suppressing the diffraction of digital noises to the analog block power supply resulting from impedance common to the wiring patterns. For the GND line, give consideration to design the patterns in a similar manner.
Furthermore, for all power supply terminals to ICs, mount a capacitor between the power supply and the GND terminal. At the same time, in order to use an electrolytic capacitor, thoroughly check to be sure the characteristics of the capacitor to be used present no problem including the occurrence of capacity dropout at a low temperature, thus determining the constant.
- 5) GND voltage
Make setting of the potential of the GND terminal so that it will be maintained at the minimum in any operating state. Furthermore, check to be sure no terminals are at a potential lower than the GND voltage including an actual electric transient.
- 6) Short circuit between terminals and erroneous mounting
In order to mount ICs on a set PCB, pay thorough attention to the direction and offset of the ICs. Erroneous mounting can break down the ICs. Furthermore, if a short circuit occurs due to foreign matters entering between terminals or between the terminal and the power supply or the GND terminal, the ICs can break down.
- 7) Operation in strong electromagnetic field
Be noted that using ICs in the strong electromagnetic field can malfunction them.
- 8) Inspection with set PCB
On the inspection with the set PCB, if a capacitor is connected to a low-impedance IC terminal, the IC can suffer stress. Therefore, be sure to discharge from the set PCB by each process. Furthermore, in order to mount or dismount the set PCB to/from the jig for the inspection process, be sure to turn OFF the power supply and then mount the set PCB to the jig. After the completion of the inspection, be sure to turn OFF the power supply and then dismount it from the jig. In addition, for protection against static electricity, establish a ground for the assembly process and pay thorough attention to the transportation and the storage of the set PCB.
- 9) Input terminals
In terms of the construction of IC, parasitic elements are inevitably formed in relation to potential. The operation of the parasitic element can cause interference with circuit operation, thus resulting in a malfunction and then breakdown of the input terminal. Therefore, pay thorough attention not to handle the input terminals, such as to apply to the input terminals a voltage lower than the GND respectively, so that any parasitic element will operate. Furthermore, do not apply a voltage to the input terminals when no power supply voltage is applied to the IC. In addition, even if the power supply voltage is applied, apply to the input terminals a voltage lower than the power supply voltage or within the guaranteed value of electrical characteristics.
- 10) Ground wiring pattern
If small-signal GND and large-current GND are provided, It will be recommended to separate the large-current GND pattern from the small-signal GND pattern and establish a single ground at the reference point of the set PCB so that resistance to the wiring pattern and voltage fluctuations due to a large current will cause no fluctuations in voltages of the small-signal GND. Pay attention not to cause fluctuations in the GND wiring pattern of external parts as well.
- 11) External capacitor
In order to use a ceramic capacitor as the external capacitor, determine the constant with consideration given to a degradation in the nominal capacitance due to DC bias and changes in the capacitance due to temperature, etc.
- 12) Thermal shutdown circuit (TSD)
When junction temperatures become 175°C (typ) or higher, the thermal shutdown circuit operates and turns a switch OFF. The thermal shutdown circuit, which is aimed at isolating the LSI from thermal runaway as much as possible, is not aimed at the protection or guarantee of the LSI. Therefore, do not continuously use the LSI with this circuit operating or use the LSI assuming its operation.
- 13) Thermal design
Perform thermal design in which there are adequate margins by taking into account the permissible dissipation (Pd) in actual states of use.
- 14) Selection of coil
Select the low DCR inductors to decrease power loss for DC/DC converter.

●Ordering part number

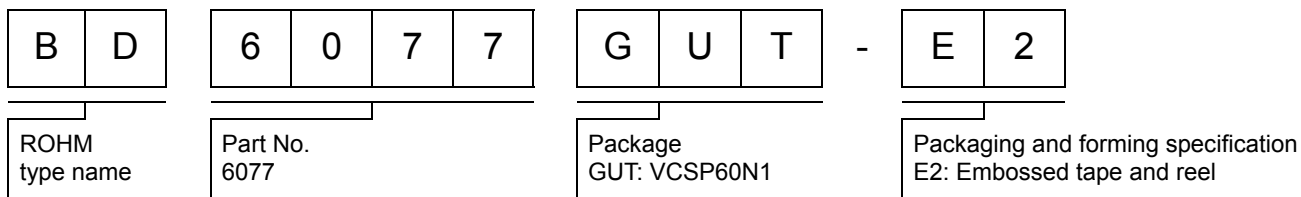

VCSP60N1 (BD6077GUT)

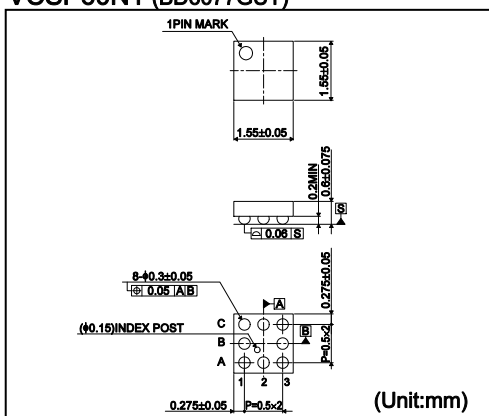

<Tape and Reel information>

Tape	Embossed carrier tape
Quantity	3000pcs
Direction of feed	E2 (The direction is the 1pin of product is at the upper left when you hold reel on the left hand and you pull out the tape on the right hand)

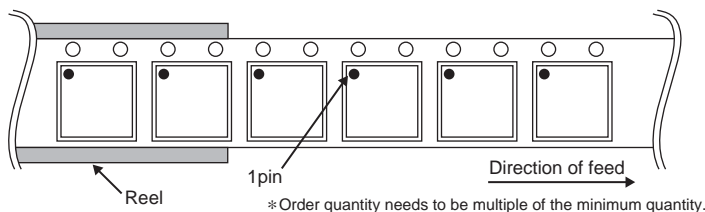

Notes

No copying or reproduction of this document, in part or in whole, is permitted without the consent of ROHM Co.,Ltd.

The content specified herein is subject to change for improvement without notice.

The content specified herein is for the purpose of introducing ROHM's products (hereinafter "Products"). If you wish to use any such Product, please be sure to refer to the specifications, which can be obtained from ROHM upon request.

Examples of application circuits, circuit constants and any other information contained herein illustrate the standard usage and operations of the Products. The peripheral conditions must be taken into account when designing circuits for mass production.

Great care was taken in ensuring the accuracy of the information specified in this document. However, should you incur any damage arising from any inaccuracy or misprint of such information, ROHM shall bear no responsibility for such damage.

The technical information specified herein is intended only to show the typical functions of and examples of application circuits for the Products. ROHM does not grant you, explicitly or implicitly, any license to use or exercise intellectual property or other rights held by ROHM and other parties. ROHM shall bear no responsibility whatsoever for any dispute arising from the use of such technical information.

The Products specified in this document are intended to be used with general-use electronic equipment or devices (such as audio visual equipment, office-automation equipment, communication devices, electronic appliances and amusement devices).

The Products specified in this document are not designed to be radiation tolerant.

While ROHM always makes efforts to enhance the quality and reliability of its Products, a Product may fail or malfunction for a variety of reasons.

Please be sure to implement in your equipment using the Products safety measures to guard against the possibility of physical injury, fire or any other damage caused in the event of the failure of any Product, such as derating, redundancy, fire control and fail-safe designs. ROHM shall bear no responsibility whatsoever for your use of any Product outside of the prescribed scope or not in accordance with the instruction manual.

The Products are not designed or manufactured to be used with any equipment, device or system which requires an extremely high level of reliability the failure or malfunction of which may result in a direct threat to human life or create a risk of human injury (such as a medical instrument, transportation equipment, aerospace machinery, nuclear-reactor controller, fuel-controller or other safety device). ROHM shall bear no responsibility in any way for use of any of the Products for the above special purposes. If a Product is intended to be used for any such special purpose, please contact a ROHM sales representative before purchasing.

If you intend to export or ship overseas any Product or technology specified herein that may be controlled under the Foreign Exchange and the Foreign Trade Law, you will be required to obtain a license or permit under the Law.



Thank you for your accessing to ROHM product informations.
More detail product informations and catalogs are available, please contact us.

ROHM Customer Support System

<http://www.rohm.com/contact/>

