



LA75665M

VIF/SIF IF Signal-Processing Circuit with TV/VCR PAL and NTSC Multisound Support

Overview

The LA75665M is a VIF/SIF IC that supports PAL and NTSC multisound and that adopts a semi-adjustment-free system. To simplify adjustment, the VIF block adopts a technique in which AFT adjustment is no longer required by VCO adjustment. The SIF block supports audio multi-detection by adopting a PLL detection technique. The SIF block provides 4 inputs with IC internal switching for easy design of multi-sound systems. Additionally, these switches can also be used for video system sound trap switching. The LA7566 also includes a buzz canceller that suppresses Nyquist buzz to achieve improved audio quality.

Features

- No coils are used in the AFT and SIF blocks, making these circuits adjustment free.
- PAL / NTSC multisound system can be constructed easily.
- Built-in buzz canceller for excellent audio performance

Functions

[VIF Block]

- VIF amplifier
- PLL detector
- BNC
- RF AGC
- EQ amplifier
- AFT
- IF AGC
- Buzz canceller

[First SIF Block]

- First SIF amplifier
- First SIF detector
- AGC

[SIF Block]

- Multiple input switch
- Limiter amplifier
- PLL FM detector

Package Dimensions

unit: mm

3112-MFP24S

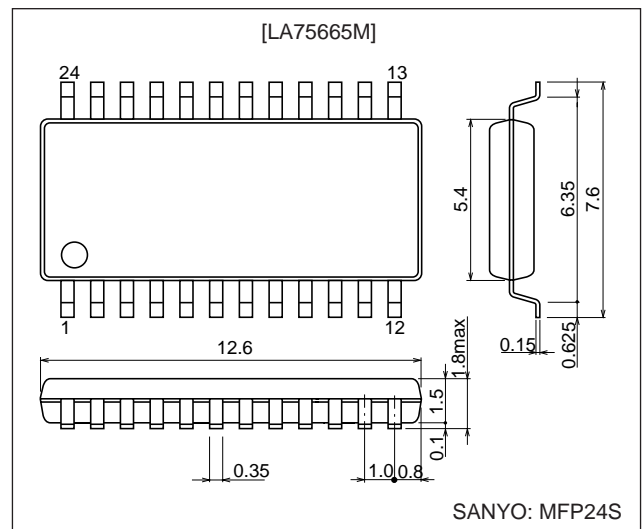

■ Any and all SANYO products described or contained herein do not have specifications that can handle applications that require extremely high levels of reliability, such as life-support systems, aircraft's control systems, or other applications whose failure can be reasonably expected to result in serious physical and/or material damage. Consult with your SANYO representative nearest you before using any SANYO products described or contained herein in such applications.

■ SANYO assumes no responsibility for equipment failures that result from using products at values that exceed, even momentarily, rated values (such as maximum ratings, operating condition ranges, or other parameters) listed in products specifications of any and all SANYO products described or contained herein.

SANYO Electric Co.,Ltd. Semiconductor Company

TOKYO OFFICE Tokyo Bldg., 1-10, 1 Chome, Ueno, Taito-ku, TOKYO, 110-8534 JAPAN

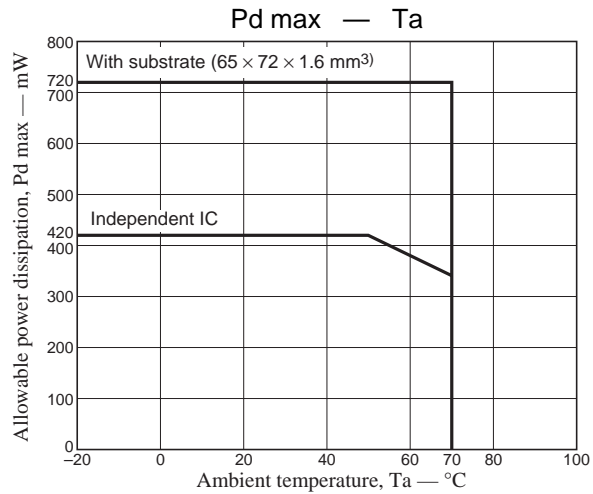

Specifications

Maximum Ratings at Ta = 25°C

Parameter	Symbol	Conditions	Ratings	Unit
Maximum supply voltage	V _{CC} max		6	V
Circuit voltage	V7, V10,		V _{CC}	V
Circuit current	I1		-2	mA
	I13		-3	mA
	I18		-10	mA
Allowable power dissipation	Pd max	Ta ≤ 50°C, independent IC	420	mW
		When mounted on a printed circuit board*	720	mW
Operating temperature	T _{opr}		-20 to +70	°C
Storage temperature	T _{stg}		-55 to +150	°C

Note: * Size: 65 × 72 × 1.6 mm³, Material: paper/phenol composite

Operating Conditions at Ta = 25°C

Parameter	Symbol	Conditions	Ratings	Unit
Recommended supply voltage	V _{CC}		5	V
Operating supply voltage range	V _{CC} op		4.6 to 5.5	V

LA75665M

Operating Characteristics at $T_a = 25^\circ\text{C}$, $V_{CC} = 5\text{ V}$, $f_p = 38.9\text{ MHz}$

Parameter	Symbol	Conditions	Ratings			Unit
			min	typ	max	
[VIF Block]						
Circuit current	I3		39	46	53	mA
Maximum RF AGC voltage	V9H		4.5	4.9		V
Minimum RF AGC voltage	V9L			0	0.5	V
Input sensitivity	V_{IN}	S1 = OFF	29	35	41	$\text{dB}\mu\text{V}$
AGC range	G_R		45	50		dB
Maximum allowable input	$V_{IN\text{ max}}$		95	100		$\text{dB}\mu\text{V}$
No-signal video output voltage	V13		3.2	3.5	3.8	V
Sync tip voltage	V13 tip		0.8	1.0	1.2	V
Video output level	V_O		1.75	2.1	2.42	Vp-p
Black noise threshold voltage	V_{BTH}		0.3	0.6	0.9	V
Black noise clamp voltage	V_{BCL}		1.5	1.8	2.1	V
Video signal-to-noise ratio	S/N		48	52		dB
C-S beat	IC-S		44	49		dB
Frequency characteristics	f_C	6 MHz	-3	-1.5		dB
Differential gain	DG			3	8	%
Differential phase	DP			3	8	deg
AFT voltage with no input signal	V10		4	4.5	5.0	V
Maximum AFT voltage	V10H		4.2	4.8	5.0	V
Minimum AFT voltage	V10L		0	0.1	0.2	V
AFT detection sensitivity	Sf		19	25	32	mV/kHz
VIF input resistance	R_i	38.9 MHz		1.5		$\text{k}\Omega$
VIF input capacitance	C_i	38.9 MHz		3		pF
APC pull-in range (U)	f_{PU}		1.0	1.5		MHz
APC pull-in range (L)	f_{PL}			-1.5	-0.8	MHz
AFT tolerance frequency 1	df_{a1}		-200	0	+200	kHz
VCO 1 maximum variability range (U)	df_u		1.3	1.5		MHz
VCO 1 maximum variability range (L)	df_l			-1.5	-0.75	MHz
VCO control sensitivity	B		1.25	2.3	5.0	kHz/mV
Drift when the AFT switch is on	Drift				3	s
[First SIF Block]						
Conversion gain	VG		28	31	34	dB
5.5 MHz output level	S_O		125	177	251	mVrms
Maximum first SIF input	$S_{IN\text{ max}}$		500	1000		mVrms
First SIF input resistance	$R_{IN}(\text{SIF})$	33.4 MHz		2		$\text{k}\Omega$
First SIF input capacitance	$C_{IN}(\text{SIF})$	33.4 MHz		3		pF
[SIF Block]						
Limiting sensitivity	$V_{li}(\text{lim})$			36	42	$\text{dB}\mu\text{V}$
FM detector output voltage	$V_O(\text{FM})$	5.5 MHz \pm 30 kHz	450	570	720	mVrms
AM rejection ratio	AMR		50	60		dB
Total harmonic distortion	THD			0.2	1.5	%
SIF S/N	S/N (FM)		55	60		dB
FM detector output DC voltage	FMDC		1.9	2.2	2.5	V
[SIF Switch Block] Switches A, B, and C: H = open, L = ground						
NTSC mode 6-dB amplifier	NTSW		5	6	7	dB
SIF crosstalk 21	CT21		51	57		dB
SIF crosstalk 22	CT22		51	57		dB
SIF crosstalk 23	CT23		51	57		dB
SIF crosstalk 24	CT24		51	57		dB
Switch threshold low-level voltage	SW (L)		1.0	1.5	2.0	V

LA75665M

Pin Assignment

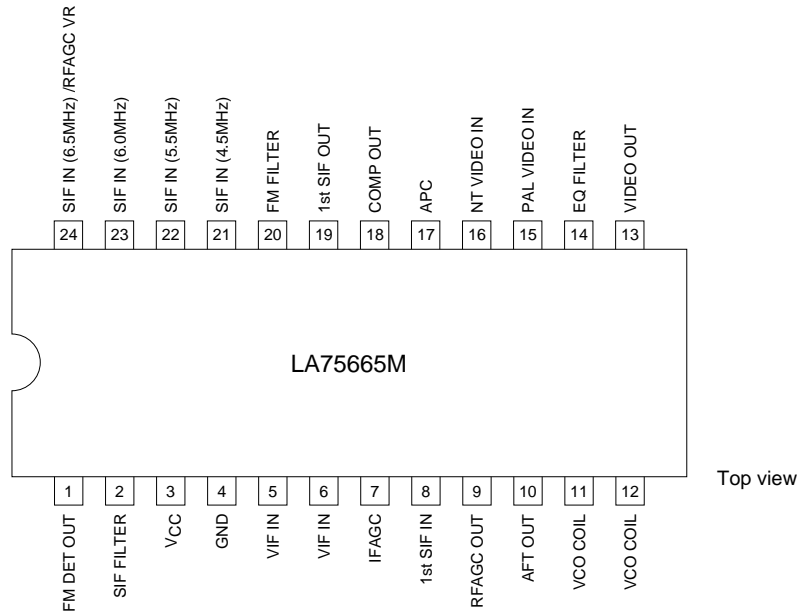

Top view

Application Circuit Diagram

A12481

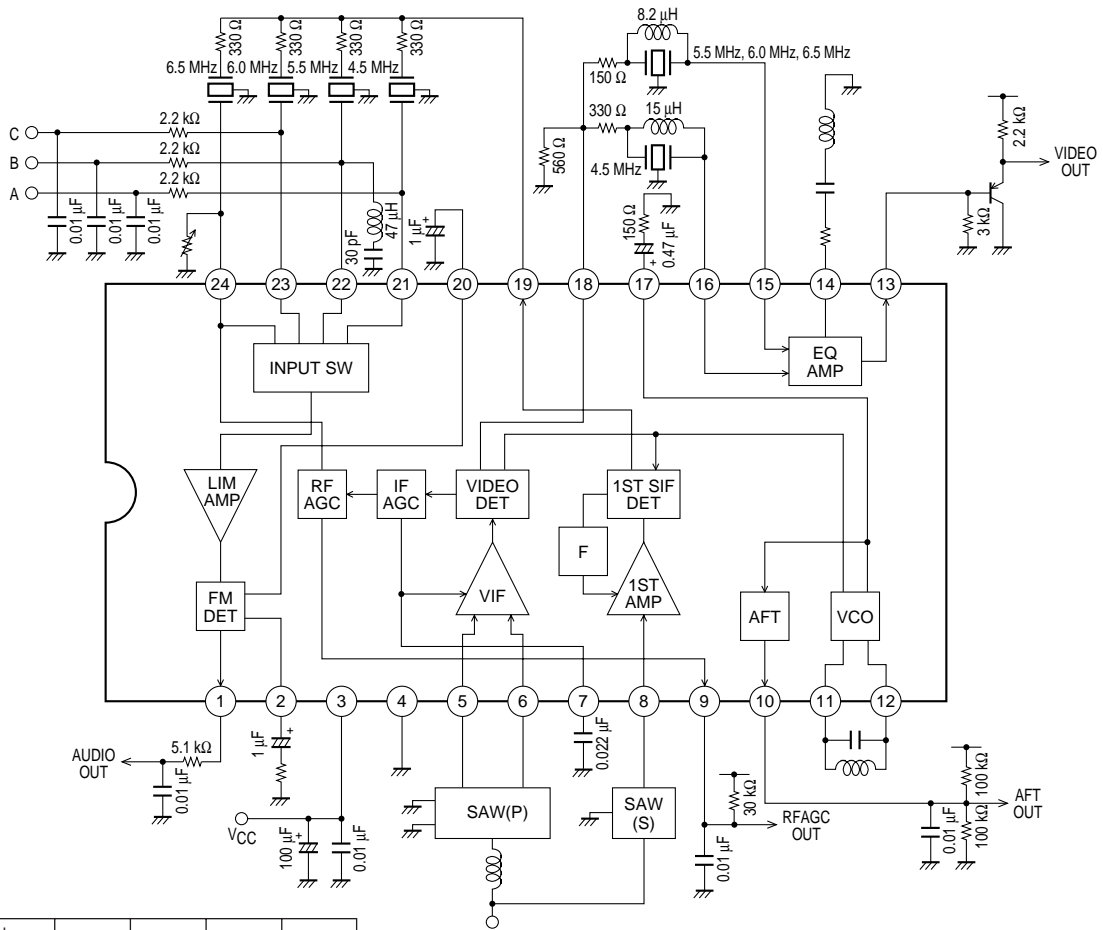

A12482

Switch			5.5 MHz	6.0 MHz	6.5 MHz	4.5 MHz
A	B	C				
H	H	H	○			
H	H	L		○		
H	L	H			○	
H	L	L				○
L	H	H	○	○	○	
L	L	L	○	○	○	○
L	H	L		○	○	
L	L	H		○	○	

H : OPEN
L : GND

LA75665M

Pin Functions

Pin No.	Symbol	Pin function	Equivalent circuit
1	FM DET OUT	<ul style="list-style-type: none"> • Audio FM detector output This circuit includes an internal 300 Ω resistor in series with the emitter-follower output. • Stereo applications The input impedance may be reduced according to the applications that input this signal to a stereo decoder. This can result in distortion in the left and right signals and a degradation of the stereo characteristics. If this problem occurs, add a resistor between pin 24 and ground. $R1 \geq 5.1 \text{ k}\Omega$ • Mono applications Forms an external deemphasis circuit. $t = CR2$ 	<p style="text-align: right;">A12486</p>
2	SIF FILTER	<ul style="list-style-type: none"> • Connection for a filter that holds the FM detector output DC voltage at a fixed level. Normally, a 1-μF electrolytic capacitor is used. To improve the low band (around 50 Hz) frequency characteristics, increase the value of this capacitor (C1). The FM detector output level can be reduced and the FM dynamic range increased by inserting this resistor in series with the capacitor. 	<p style="text-align: right;">A12487</p>
5 6	VIF IN	<ul style="list-style-type: none"> • VIF amplifier input. The input circuit is constructed as a balanced input, and the input has the following impedance characteristics: $R \approx 1.5 \text{ k}\Omega$ $C \approx 3 \text{ pF}$ 	<p style="text-align: right;">A12488</p>

Continued on next page.

LA75665M

Continued from preceding page.

Pin No.	Symbol	Pin function	Equivalent circuit
7	IF AGC	<ul style="list-style-type: none"> IF AGC filter connection. <p>The AGC voltage is created at pin 7 from the signal to which peak detection was applied by the internal AGC detector. Additionally, the IC includes an internal second AGC filter (a lag-lead filter) used to create a dual time constant. A 0.022 μF capacitor is used as the external capacitor. The value of this capacitor must be adjusted according to measurement of the sag, AGC speed, and other circuit aspects.</p>	<p style="text-align: right;">A12489</p>
8	1st SIF IN	<ul style="list-style-type: none"> First SIF input. <p>A DC cut capacitor must be inserted in the input to this circuit.</p> <p>When a SAW filter is used: The first SIF sensitivity can be increased by inserting an inductor between the SAW and the IC to match the SAW output and IC input capacitances.</p> <p>When an intercarrier system is used: This pin must be connected to ground through a capacitor.</p>	<p style="text-align: right;">A12490</p>
9	RF AGC OUT	<ul style="list-style-type: none"> RF AGC output. <p>This output controls the tuner RF AGC. This is an open-collector output with an inserted 100-Ω protective resistor. Determine the value of the external bleeder resistor to match the tuner specifications.</p>	<p style="text-align: right;">A12491</p>
10	AFT OUT	<ul style="list-style-type: none"> AFT output. <p>The AFT center voltage is created with an external bleeder resistor. The AFT gain increases as the value of this bleeder resistor increases. The value of this resistor must not exceed 390 kΩ. This circuit includes a control function that controls the AFT voltage to be equal to the center voltage in weak field reception conditions.</p>	<p style="text-align: right;">A12492</p>

Continued on next page.

LA75665M

Continued from preceding page.

Pin No.	Symbol	Pin function	Equivalent circuit
11 12	VCO	<ul style="list-style-type: none"> VCO tank circuit used for video detection. <p>See the separately provided documentation for the tank circuit coil (inductor) specifications.</p>	<p style="text-align: right;">A12493</p>
13 14	VIDEO OUT EQ FILTER	<ul style="list-style-type: none"> Equalizer circuit. This circuit corrects the video signal frequency characteristics. Notes on equalizer amplifier design: The equalizer amplifier is designed as a voltage follower amplifier with a gain of about 2.3 dB. When the frequency characteristics are corrected, connect an inductor, a capacitor, and a resistor in series between pin 14 and ground. <p>The equalizer amplifier gain is given by:</p> $AV = \frac{R1}{Z} + 1$ <p>Here, R1 is an IC internal resistor with a value of 1 kΩ. Select Z according to the desired characteristics. However, care is required to prevent distortion at the resonant point determined by Z, where the gain is maximum.</p>	<p style="text-align: right;">A12494</p>
15 16	PAL VIDEO IN NT VIDEO IN	<ul style="list-style-type: none"> Equalizer amplifier inputs. <p>Pin 15 is for PAL, and pin 16 for NTSC format signals. These inputs are linked to and switched by the SIF switches.</p>	<p style="text-align: right;">A12495</p>
17	APC FILTER	<ul style="list-style-type: none"> PLL detector APC filter connection. <p>The APC time constants are switched internally in the IC. When locked, the VCO is controlled over the path A, and the loop gain is reduced. When unlocked and during weak field reception, the VCO is controlled over the path B, thus increasing the loop gain.</p> <p>We recommend values of: R = 150 to 390 Ω, and C = 0.47 μF for the loop filter constants.</p>	<p style="text-align: right;">A12496</p>

Continued on next page.

LA75665M

Continued from preceding page.

Pin No.	Symbol	Pin function	Equivalent circuit																																																																						
18	COMP OUT	<ul style="list-style-type: none"> Output for the video signal that includes the SIF carrier. <p>A resistor must be inserted between pin 18 and ground to acquire an adequate drive capability. $R \geq 470 \Omega$</p>																																																																							
19	1st SIF OUT	<ul style="list-style-type: none"> First SIF output <p>The signal output from this pin is passed through a bandpass filter and input to the SIF circuit. This is an emitter-follower output.</p>																																																																							
20	FM FILTER	<ul style="list-style-type: none"> The FM detector signal-to-noise ratio can be improved by inserting a filter in the FM detector bias line. <p>C1 should have a value of 0.47 μF or greater, and 1 μF is recommended .</p> <p>If the FM detector is not used, pin 20 must be connected to ground through a 2-kΩ resistor. This stops the FM detector VCO circuit.</p>																																																																							
21 22 23 24	SIF IN (4.5 MHz) SIF IN (5.5 MHz) SIF IN (6.0 MHz) SIF IN (6.5 MHz) RF AGC VR	<ul style="list-style-type: none"> SIF inputs. <p>Four input pins are provided to support multi-side systems, and a switching function is also included. Since buzzing and bass beating can occur if interference signals, such as the video signal or the chrominance signal, enter these pins, extra care must be taken in designing the input circuit pattern layout. Note that pin 24 also functions as the RF AGC adjustment pin. This pin sets the tuner RF AGC operating point. Also, the FM output and the video output can be muted at the same time by setting this pin to the ground level.</p> <table border="1" style="margin: 10px auto; border-collapse: collapse; text-align: center;"> <thead> <tr> <th colspan="3">Switch</th> <th>5.5 MHz</th> <th>6.0 MHz</th> <th>6.5 MHz</th> <th>4.5 MHz</th> </tr> <tr> <th>A</th> <th>B</th> <th>C</th> <th></th> <th></th> <th></th> <th></th> </tr> </thead> <tbody> <tr> <td>H</td> <td>H</td> <td>H</td> <td>○</td> <td></td> <td></td> <td></td> </tr> <tr> <td>H</td> <td>H</td> <td>L</td> <td></td> <td>○</td> <td></td> <td></td> </tr> <tr> <td>H</td> <td>L</td> <td>H</td> <td></td> <td></td> <td>○</td> <td></td> </tr> <tr> <td>H</td> <td>L</td> <td>L</td> <td></td> <td></td> <td></td> <td>○</td> </tr> <tr> <td>L</td> <td>H</td> <td>H</td> <td>○</td> <td>○</td> <td>○</td> <td></td> </tr> <tr> <td>L</td> <td>L</td> <td>L</td> <td></td> <td>○</td> <td>○</td> <td>○</td> </tr> <tr> <td>L</td> <td>H</td> <td>L</td> <td></td> <td>○</td> <td>○</td> <td></td> </tr> <tr> <td>L</td> <td>L</td> <td>H</td> <td></td> <td>○</td> <td>○</td> <td></td> </tr> </tbody> </table>	Switch			5.5 MHz	6.0 MHz	6.5 MHz	4.5 MHz	A	B	C					H	H	H	○				H	H	L		○			H	L	H			○		H	L	L				○	L	H	H	○	○	○		L	L	L		○	○	○	L	H	L		○	○		L	L	H		○	○		
Switch			5.5 MHz	6.0 MHz	6.5 MHz	4.5 MHz																																																																			
A	B	C																																																																							
H	H	H	○																																																																						
H	H	L		○																																																																					
H	L	H			○																																																																				
H	L	L				○																																																																			
L	H	H	○	○	○																																																																				
L	L	L		○	○	○																																																																			
L	H	L		○	○																																																																				
L	L	H		○	○																																																																				

Notes on Sanyo SAW Filters

There are two types of SAW filters, which differ in the piezoelectric substrate material, as follows:

1. Lithium tantalate (LiTaO3) SAW filter

TSF11 □ □ Japan

TSF12 □ □ US

Although lithium tantalate SAW filters have the low temperature coefficient of $-18 \text{ ppm}/^\circ\text{C}$, they suffer from a large insertion loss. However, it is possible, at the cost of increasing the number of external components required, to minimize this insertion loss by using a matching circuit consisting of coils and other components at the SAW filter output. At the same time as minimizing insertion loss, this technique also allows the frequency characteristics, level, and other aspects to be varied, and thus provides increased circuit design flexibility. Also, since the SAW filter reflected wave level is minimal, the circuit can be designed with a small in-band ripple level.

2. Lithium niobate (LiNbO3) SAW filter

TSF52 □ □ US

TSF53 □ □ PAL

Although lithium niobate SAW filters have the high temperature coefficient of $-72 \text{ ppm}/^\circ\text{C}$, they feature an insertion loss about 10 dB lower than that of lithium tantalate SAW filters. Accordingly, there is no need for a matching circuit at the SAW filter output. Although the in-band ripple is somewhat larger than with lithium tantalate SAW filters, since they have a low impedance and a small field slew, they are relatively immune to influences from peripheral circuit components and the geometry of the printed circuit board pattern. This allows stable out-of-band trap characteristics to be acquired. Due to the above considerations, lithium tantalate SAW filters are used in applications for the US and Japan that have a high IF frequency, and lithium niobate SAW filters are used in PAL and US applications that have a low IF frequency.

Notes on SAW Filter Matching

In SAW filter input circuit matching, rather than matching the IF frequency, flatter video band characteristics can be acquired by designing the tuning point to be in the vicinity of the audio carrier rather than near the chrominance carrier. The situation shown in figure on the right makes it easier to acquire flat band characteristics than that in figure on the left.

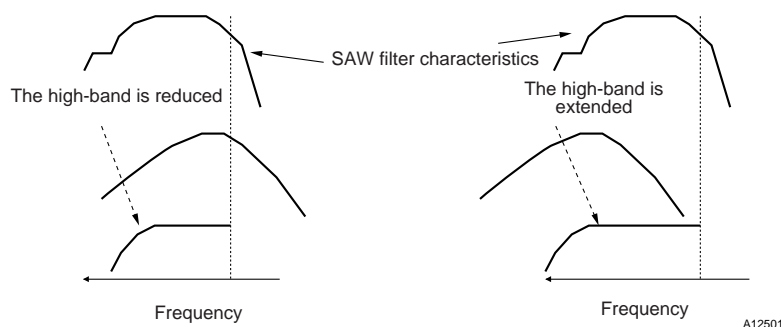

With the tuning set to the IF frequency

With the tuning set to the vicinity of S and C

Coil Specifications

	JAPAN $f = 58.75 \text{ MHz}$	US $f = 45.75 \text{ MHz}$	PAL $f = 38.9 \text{ MHz}$
VCO coils	<p>Test production No. 16991A Tokyo Parts Industrial Co., Ltd.</p>	<p>Test production No. 16687A Tokyo Parts Industrial Co., Ltd.</p>	<p>Test production No. 16686A Tokyo Parts Industrial Co., Ltd.</p>
SAW filters (split)	Picture TSF1137U SOUND	Picture TSF1241 SOUND	Picture TSF5315 SOUND
SAW filters (inter)		TSF5220 TSF5221	TSF5321 TSF5344

Tokyo Parts Industrial Co., Ltd. 236 Hinode Machi Isesaki Shi, Gunma Prefecture Japan TEL: +81-270-23-3731

Notes on VCO Tank Circuits

1. Built-in capacitor VCO tank circuits

When the power is turned on, the heat generated by the IC is transmitted through the printed circuit board to the VCO tank circuit. At this point, the VCO coil frame functions as a heat sink and the IC heat is dissipated. As a result, it becomes more difficult to transmit heat to the VCO tank circuit's built-in capacitor, and the influence of drift at power on is reduced. Therefore, it suffices to design the circuit so that the coil and capacitor thermal characteristics cancel. Ideally, it is better to use a coil with a core material that has low temperature coefficient characteristics.

2. External capacitor VCO tank circuits

When an external capacitor is used, heat generated by the IC is transmitted through the printed circuit board directly to the VCO tank circuit external capacitor. While this capacitor is heated relatively early after the power is turned on, the coil is not influenced as much by this heat, and as a result the power-on drift is increased. Accordingly, a coil whose core material has low temperature coefficient characteristics must be used. It is also desirable to use a capacitor with similarly low temperature coefficient characteristics.

Note: Applications that use an external capacitor here must use a chip capacitor. If an ordinary capacitor is used, problems such as the oscillator frequency changing with the capacitor orientation may occur.

- Specifications of any and all SANYO products described or contained herein stipulate the performance, characteristics, and functions of the described products in the independent state, and are not guarantees of the performance, characteristics, and functions of the described products as mounted in the customer's products or equipment. To verify symptoms and states that cannot be evaluated in an independent device, the customer should always evaluate and test devices mounted in the customer's products or equipment.
- SANYO Electric Co., Ltd. strives to supply high-quality high-reliability products. However, any and all semiconductor products fail with some probability. It is possible that these probabilistic failures could give rise to accidents or events that could endanger human lives, that could give rise to smoke or fire, or that could cause damage to other property. When designing equipment, adopt safety measures so that these kinds of accidents or events cannot occur. Such measures include but are not limited to protective circuits and error prevention circuits for safe design, redundant design, and structural design.
- In the event that any or all SANYO products (including technical data, services) described or contained herein are controlled under any of applicable local export control laws and regulations, such products must not be exported without obtaining the export license from the authorities concerned in accordance with the above law.
- No part of this publication may be reproduced or transmitted in any form or by any means, electronic or mechanical, including photocopying and recording, or any information storage or retrieval system, or otherwise, without the prior written permission of SANYO Electric Co., Ltd.
- Any and all information described or contained herein are subject to change without notice due to product/technology improvement, etc. When designing equipment, refer to the "Delivery Specification" for the SANYO product that you intend to use.
- Information (including circuit diagrams and circuit parameters) herein is for example only; it is not guaranteed for volume production. SANYO believes information herein is accurate and reliable, but no guarantees are made or implied regarding its use or any infringements of intellectual property rights or other rights of third parties.

This catalog provides information as of November, 1999. Specifications and information herein are subject to change without notice.