

Fast Recovery Diodes (Stud Version), 85A



FEATURES

- Short reverse recovery time
- Low stored charge
- Wide current range
- Excellent surge capabilities
- Stud cathode and stud anode versions
- Voltage up to 1200 V_{RRM}
- Compliant to RoHS directive 2002/95/EC

TYPICAL APPLICATIONS

- DC power supplies
- Inverters
- Converters
- Choppers
- Ultrasonic systems
- Freewheeling diodes



DO-203AB(DO-5)

| PRODUCT SUMMARY | |
|--------------------|-----|
| I _{F(AV)} | 85A |

| MAJOR RATINGS AND CHARACTERISTICS | | | |
|-----------------------------------|------------------------|------------------------------------|-------------------|
| SYMBOL | CHARACTERISTICS | 85FD(R) | UNIT |
| I _{F(AV)} | | 85 | A |
| | Maximum T _C | 85 | °C |
| I _{FSM} | 50 HZ | 1308 | A |
| | 60 HZ | 1369 | |
| I ² t | 50 HZ | 8554 | A ² s |
| | 60 HZ | 7778 | |
| I ² √t | | 85543 | I ² √s |
| V _{RRM} | Range | 200 to 1200 | V |
| t _{rr} | | See Recovery Characteristics table | ns |
| T _J | Range | -40 to 125 | °C |

ELECTRICAL SPECIFICATIONS

| VOLTAGE RATINGS | | | | | |
|-----------------|--------------|--|---|--|------------------------|
| TYPE NUMBER | VOLTAGE CODE | V _{RRM} , MAXIMUM PEAK REPETITIVE REVERSE VOLTAGE T _J = -40°C TO 125°C V | V _{RSM} , MAXIMUM PEAK NON-REPETITIVE REVERSE VOLTAGE T _J = 25°C TO 125°C V | I _{FM} , MAXIMUM PEAK REVERSE CURRENT AT RATED V _{RRM} mA | |
| | | | | T _J = 25°C | T _J = 125°C |
| 85FD(R) | 02 | 200 | 300 | 0.1 | 20 |
| | 04 | 400 | 500 | | |
| | 06 | 600 | 700 | | |
| | 08 | 800 | 900 | | |
| | 10 | 1000 | 1100 | | |
| | 12 | 1200 | 1300 | | |

| FORWARD CONDUCTION | | | | | |
|---|---------------|--|---|---------|-------------------|
| PARAMETER | SYMBOL | TEST CONDITIONS | | 85FD(R) | UNIT |
| Maximum average forward current at maximum case temperature | $I_{F(AV)}$ | 180° conduction, half sine wave | | 85 | A |
| | | | | 85 | °C |
| Maximum RMS forward current | $I_{F(RMS)}$ | | | 133 | A |
| Maximum peak repetitive forward current | I_{FRM} | Sinusoidal half wave, 30° conduction | | 470 | A |
| Maximum peak, one-cycle non-repetitive surge current | I_{FSM} | t = 10ms | Sinusoidal half wave, 100% V_{RRM} reapplied, initial $T_J = T_J$ maximum | 1100 | A |
| | | t = 8.3ms | | 1151 | |
| | | t = 10ms | Sinusoidal half wave, no voltage reapplied, initial $T_J = T_J$ maximum | 1308 | |
| | | t = 8.3ms | | 1369 | |
| Maximum I^2t for fusing | I^2t | t = 10ms | 100% V_{RRM} reapplied, initial $T_J = T_J$ maximum | 6050 | A ² s |
| | | t = 8.3ms | | 5498 | |
| | | t = 10ms | no voltage reapplied, initial $T_J = T_J$ maximum | 8554 | |
| | | t = 8.3ms | | 7778 | |
| Maximum $I^2\sqrt{t}$ for fusing ⁽¹⁾ | $I^2\sqrt{t}$ | t = 0.1 ms to 10 ms, no voltage reapplied | | 85543 | A ² √s |
| Maximum value of threshold voltage | $V_{F(TO)}$ | $T_J = 125^\circ\text{C}$ | | 1.128 | V |
| Maximum value of forward slope resistance | r_F | | | 2.11 | mΩ |
| Maximum forward voltage drop | V_{FM} | $T_J = 25^\circ\text{C}; I_{FM} = 265\text{A}$ | | 1.75 | V |

Note : ⁽¹⁾ I^2t for time $t_x = I^2\sqrt{t} \cdot \sqrt{t_x}$

| SWITCHING | | | | | |
|----------------------------------|----------|---|----------|----------|------|
| PARAMETER | SYMBOL | TEST CONDITIONS | 85FD(R) | | UNIT |
| | | | 02 to 06 | 08 to 12 | |
| Typical reverse recovery time | t_{rr} | $T_J = 25^\circ\text{C}, I_F = 1\text{A}, I_R = 1.0\text{A}, I_{RR} = 250\text{mA (RG\#1 CKT)}$ | 200 | 500 | ns |
| | | $T_J = 25^\circ\text{C}, I_F = 1\text{A to } V_R = 30\text{V}, -di_F/dt = 100\text{ A}/\mu\text{s}$ | 50 | 120 | |
| | | $T_J = 25^\circ\text{C}, -di_F/dt = 25\text{ A}/\mu\text{s}, I_{FM} = \pi \times \text{rated } I_{F(AV)}$ | 200 | 500 | |
| Typical reverse recovered charge | Q_{rr} | $T_J = 25^\circ\text{C}, I_F = 1\text{A to } V_R = 30\text{V}, -di_F/dt = 100\text{ A}/\mu\text{s}$ | 70 | 340 | nC |
| | | $T_J = 25^\circ\text{C}, -di_F/dt = 25\text{ A}/\mu\text{s}, I_{FM} = \pi \times \text{rated } I_{F(AV)}$ | 240 | 1300 | |

| THERMAL AND MECHANICAL SPECIFICATIONS | | | | |
|---|------------|--|-----------------|---------------------|
| PARAMETER | SYMBOL | TEST CONDITIONS | 85FD(R) | UNITS |
| Maximum junction operating temperature range | T_J | | -40 to 125 | °C |
| Maximum storage temperature range | T_{stg} | | - 40 to 150 | |
| Maximum thermal resistance, junction to case | R_{thJC} | DC operation | 0.30 | K/W |
| Maximum thermal resistance, case to heatsink | R_{thCS} | Mounting surface, smooth, flat and greased | 0.25 | |
| Maximum allowable mounting torque (+0%, -10%) | | Not lubricated threads, tightening on nut ⁽¹⁾ | 3.4(30) | N · m (lbf · in) |
| | | Lubricated thread, tightening on nut ⁽¹⁾ | 2.3(20) | |
| | | Not lubricated threads, tightening on hexagon ⁽²⁾ | 4.2(37) | |
| | | Lubricated thread, tightening on hexagon ⁽²⁾ | 3.2(28) | |
| Approximate weight | | | 25 | g |
| | | | 0.88 | oz. |
| Case style | | JEDEC | DO-203AB (DO-5) | |

Note : (1) Recommended for pass-through holes
 (2) Recommended for holed threaded heatsinks

| ΔR_{thJC} CONDUCTION | | | | |
|------------------------------|-----------------------|------------------------|---------------------------|-------|
| CONDUCTION ANGEL | 85FD(R) | | TEST CONDUCTIONS | UNITS |
| | SINUSOIDAL CONDUCTION | RECTANGULAR CONDUCTION | | |
| 180° | 0.37 | 0.21 | $T_J = 150^\circ\text{C}$ | K/W |
| 120° | 0.39 | 0.37 | | |
| 60° | 0.82 | 0.82 | | |
| 30° | 1.41 | 1.41 | | |

Note
 • The table above shows the increment of thermal resistance R_{thJC} when devices operate at different conduction angles than DC

| ORDERING INFORMATION SCHEME | |
|--|---------------------|
| <p>85 FD R 06 A</p> | |
| <p>Current 85 = 85A</p> | <p>85 FD R 06 A</p> |
| <p>Diode type FD = Fast Recovery Diode</p> | <p>85 FD R 06 A</p> |
| <p>Polarity R = Reverse, Anode on Stud None = standard, Cathode on Stud</p> | <p>85 FD R 06 A</p> |
| <p>Voltage 06 = 600V 08 = 800V 10 = 1000V 12 = 1200V</p> | <p>85 FD R 06 A</p> |
| <p>Trr value A = 200 ns Max. B = 500 ns Max.</p> | <p>85 FD R 06 A</p> |

Fig.1 Current rating nomogram (Sinusoidal Waveforms)

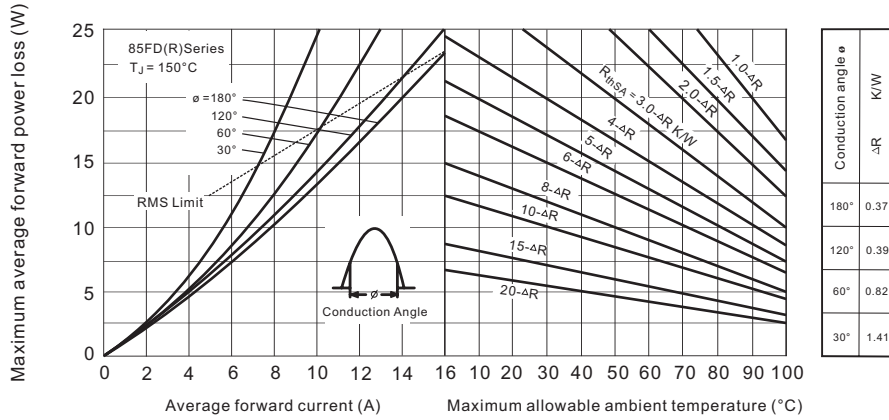

Fig.2 Current rating nomogram (Rectangular waveforms)

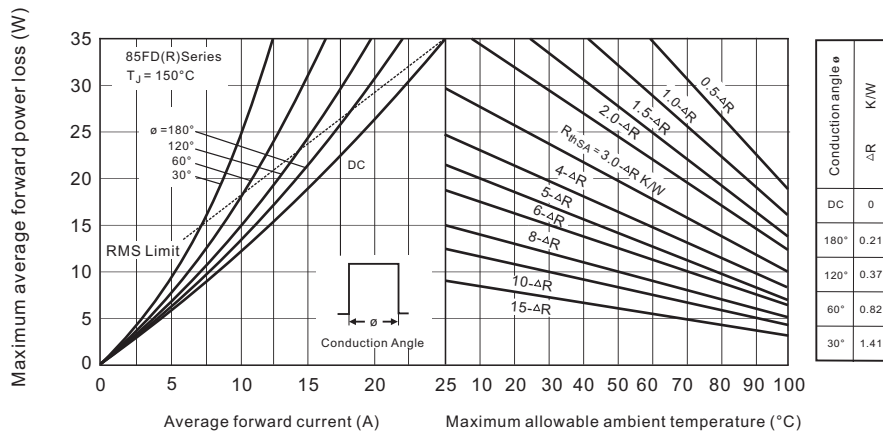

Fig.3 Maximum high level forward power loss vs. average forward current

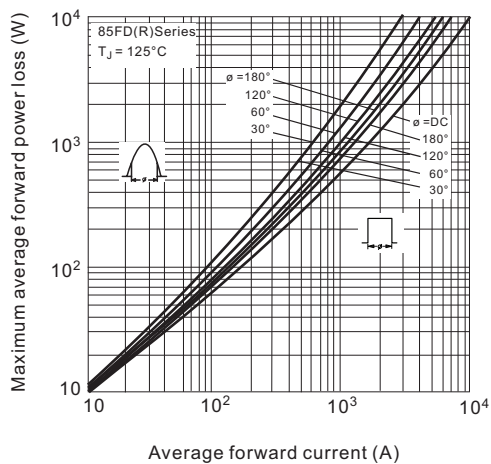

Fig.4 Maximum forward voltage vs. forward current.

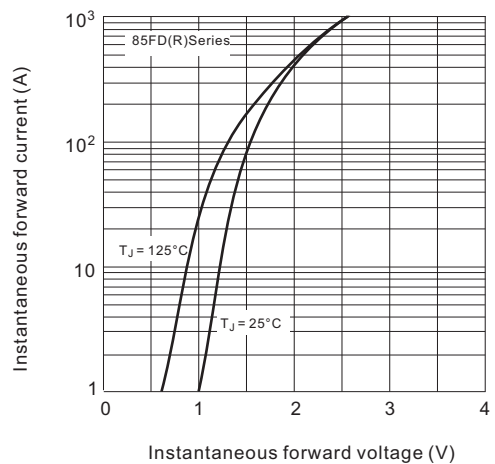

Fig.5 Average forward current vs. maximum allowable case temperature.

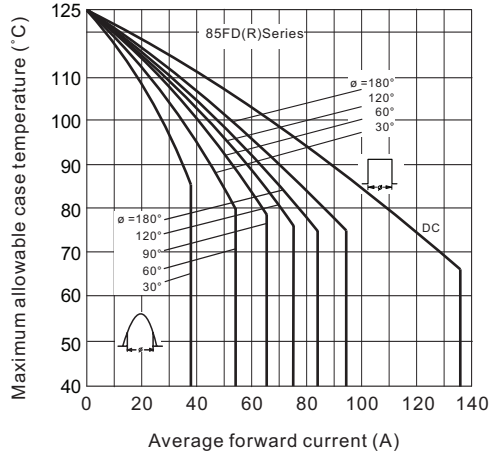

Fig.6 Typical reverse recovery time vs. rate of fall of forward current.

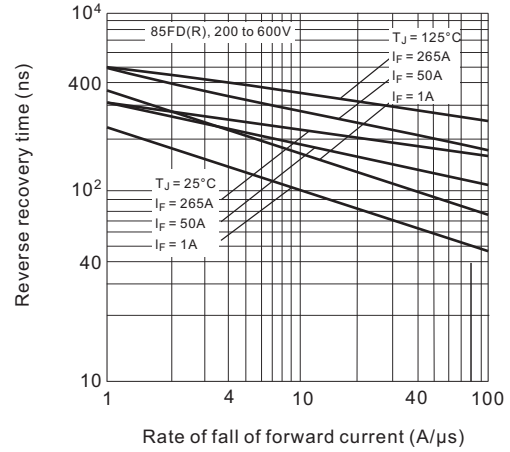

Fig.7 Typical recovered charge vs. rate of fall of forward current.

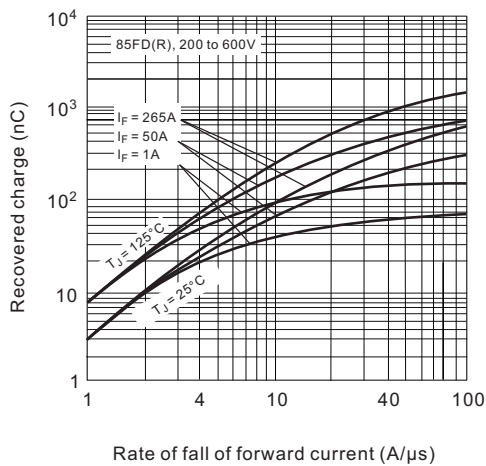

Fig.8 Typical reverse recovery time vs. rate of fall of forward current.

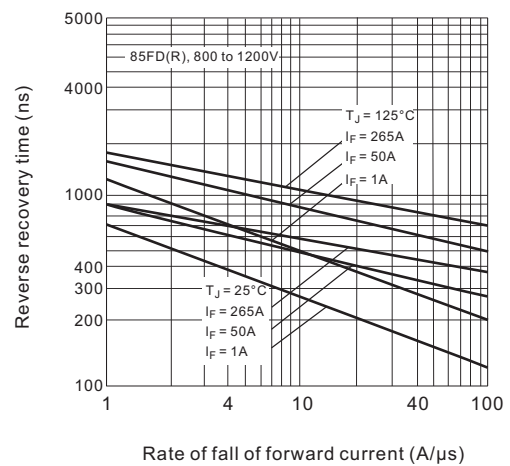
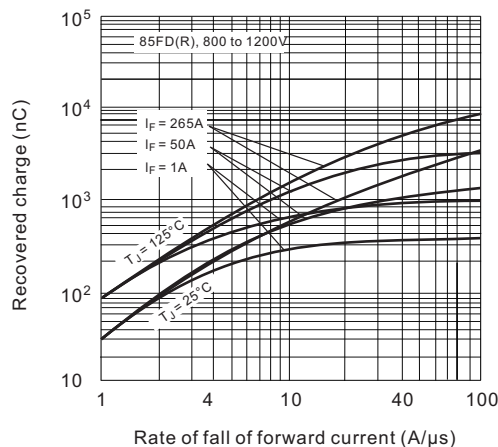
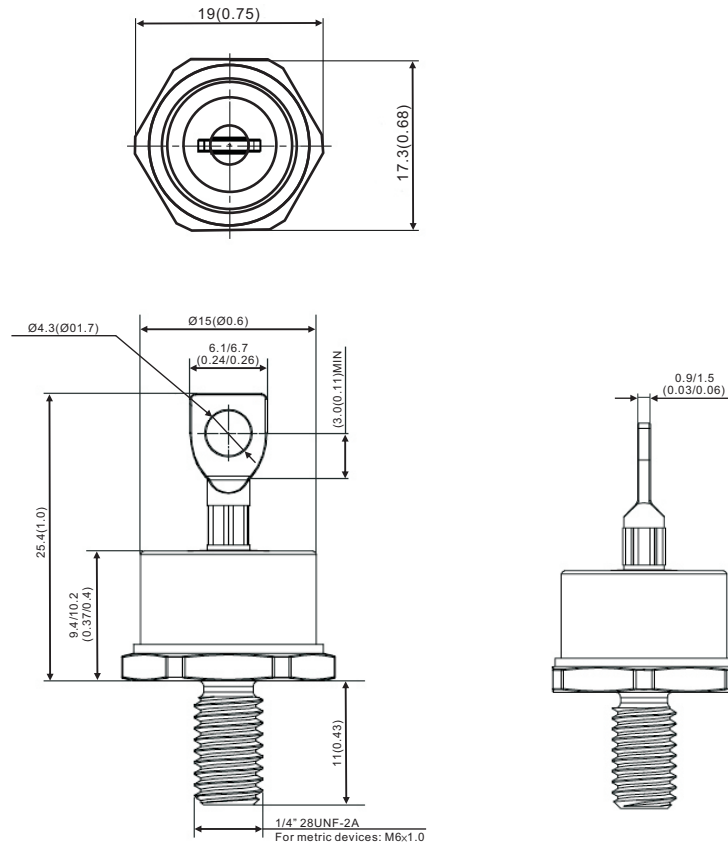

Fig.9 Typical recovered charge vs. rate of fall of forward current.



DO-203AB (DO-5)



All dimensions in millimeters (inches)

