



CERAMIC CRYSTAL RESONATORS

Crystal / MHz / KHz Ceramic Resonators

Token Electronics Industry Co., Ltd.

Taiwan: No. 137, Sec. 1, Chung Shin Rd., Wu Ku Hsiang, Taipei Hsien, Taiwan, R.O.C
TEL: 886-2-2981 0109; FAX: 886-2-2988 7487

China: 12F, Zhongxing Industry Bld., Chuangye Rd., Nanshan District, Shenzhen, Guangdong
TEL: 86-755-2605 5363, 2605 5364; FAX: 86-755-2605 5365



<http://www.token.com.tw>



rfq@token.com.tw

Product Index

Information

●	General Information	01
●	Quartz Crystal Basic Theory	02
●	Glossary & Terminology	06

Ceramic Crystal Resonators

●	TACA Series - Ceramic Housed Crystal Resonator	07
---	--	----

Notice: Specification Changed or Version Updated will be posted at irregular intervals.
All Updated and Final Specifications, Please Confirm with TOKEN ELECTRONICS
REPRESENTATIVES.

✉ : rfq@token.com.tw

🏠 : <http://www.token.com.tw>

Information of Ceramic Crystal Resonators

Advantage of Token's New Ceramic Housed Crystal Units Resonators

The emergence of wireless communications and the increased need for wireline-based data transmissions have swelled demand for piezoelectric quartz crystals and oscillators. Emerging industrial and consumer applications are steering the industry.

Data transfer must be synchronized in high-bandwidth systems, a requirement that has boosted demand for timing products. **Token crystal units (resonators) and filters** provide the precise timing signals needed to ensure reliable data transfer at high speeds in applications ranging from notebook computers to network switches.

Token use Piezoelectric processing techniques to craft resonators on quartz chips for time bases and provide very high initial accuracy and a moderately low temperature coefficient.

The markets for piezoelectric crystal products are characterized by price competition, and rapid technological change. Due to the increasing requirements for high-speed, high-frequency components as well as the demand of new consumer applications to the market, Token's ceramic housed crystal units resonators provide component engineers with a vast range of readily available solutions, necessary to meet the dynamic requirements of today's global market.

Quartz Crystal Basic Theory

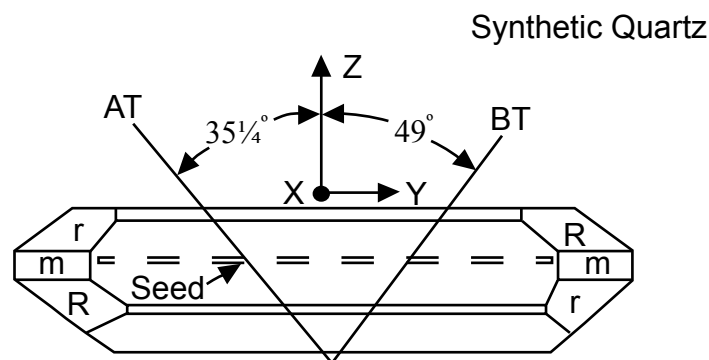

What is Quartz

The technical formula is SiO_2 and is the major constituent in many rocks and sand. The crystalline form of SiO_2 or quartz is relatively abundant in nature, but in the highly pure form required for the manufacture of quartz crystal units, the supply tends to be small. The limited supply and the high cost of natural quartz have resulted in the development of a synthetic quartz manufacturing industry. The synthetic quartz manufacturing technology turns quartz crystals an indispensable component of modern electronic production.

What is Quartz Crystal Units

Quartz units consist of a piece of piezoelectric material precisely dimensioned and orientated with respect to the crystallographic axes. This wafer (also called plate or blank) has one or more pairs of conductive electrodes, formed by vacuum evaporation. When an electric field is applied between the electrodes the piezoelectric effect excites the wafer into mechanical vibration.

Quartz crystal units (often called crystal resonators) are widely used in frequency control applications because of their unequalled combination of high Q, stability, small size and low cost. Many different substances have been investigated as possible resonator materials, but for many years quartz resonators have been preferred in satisfying needs for precise frequency control. Compared to other resonators, for example, LC circuits, mechanical resonators such as tuning forks, and piezoelectric ceramic resonators based or other single-crystal materials, the quartz resonator has an unique combination of properties.

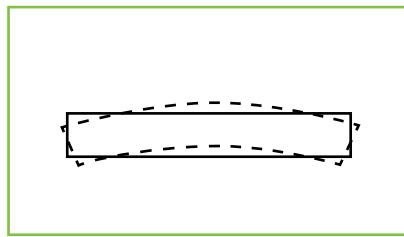

Flexure Mode

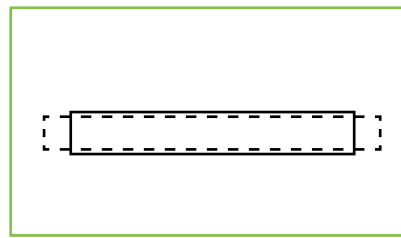

Length Extensional Mode

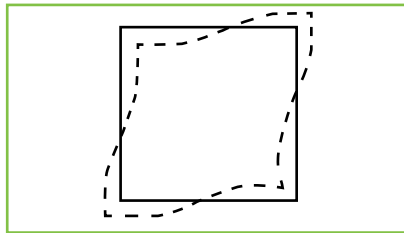

Face Shear Mode

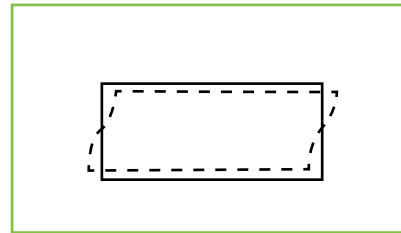

Thickness Shear Mode

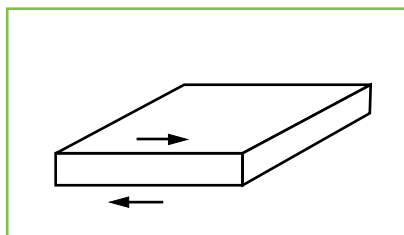

Fundamental Mode
(Thickness Shear)

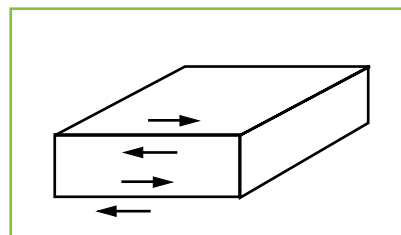

Third Overtone Mode
(Thickness)

First, the material properties of single-crystal quartz are extremely stable with time, temperature, and other environmental changes, as well as highly repeatable from one specimen to another. The acoustic loss or internal friction of quartz is very low, which results in a quartz resonator having an extremely high Q-factor. The intrinsic Q of quartz is about 107 at 1 MHz. Mounted resonators typically have Q factors ranging from tens of thousands to several hundred thousand, which is orders of magnitude better than the best LC circuits.

The second key property of the quartz resonator is its stability with respect to temperature variation. Depending on the shape and orientation of the crystal blank, many different modes of vibration can be used and it is possible to control the frequency-temperature characteristics of the quartz resonator to within close limits by an appropriate choice. The most commonly used type of resonator is the AT-cut, where the quartz blank is in the form of thin plate cut as an angle of about $35^{\circ}15'$ to the optic axis of the crystal.

The third essential characteristic of the quartz resonator is related to the stability of its mechanical properties. Short and long term stabilities manifested in frequency drifts of only a few parts per million per year are readily available from commercial units. Precision crystal units manufactured under closely controlled conditions are second only to atomic clocks in the frequency stability and precision achieved.

How Piezoelectricity Works for Quartz Unit

The word piezo-electricity takes its name from the Greek piezein “to press”, which literally means pressure electricity. Certain classes of piezoelectric materials will in general react to any mechanical stresses by producing an electrical charge. In a piezoelectric medium the strain or the displacement depends linearly on both the stress and the field. The converse effect also exists, whereby a mechanical strain is produced in the crystal by a polarising electric field. This is the basic effect which produces the vibration of a quartz crystal.

What Makes Optimal Angle of Cut So Important

The right schematic diagram (Figure-1) is a cultured quartz crystal grown from a Y-oriented seed crystal for use in fabricating AT-cut resonators. A seed crystal establishes the initial crystal orientation and encourages growth in the Y direction at the expense of the Z-axis. Seed crystals are carefully selected by Token to avoid defects which might propagate as the crystal grows. The position of the seed crystal is indicated. The lines sloping left from the x-axis mark the saw cut position for AT plates, the line sloping to the right indicates the BT-cut. In practice, these angles are very critical and are precisely determined using Bragg diffraction (also referred to as the Bragg formulation of X-ray diffraction).

The AT-cut characteristic is the most commonly used type of resonator. It has a frequency temperature coefficient described by a cubic function of temperature, which can be precisely controlled by small variations in the angle of cut. This cubic behaviour is in contrast to most other crystal cuts which give a parabolic temperature characteristic. It makes the AT-cut well suited to applications requiring a high degree of frequency stability over wide temperature ranges. Other important characteristics are aging and quality factor Q.

Vibration Modes

The AT-cut resonator uses the thickness shear mode of vibration (Figure-2). A standing wave is set up in the crystal blank by the reflection at both major surfaces of traverse waves travelling in the thickness direction. The major mechanical displacement is in the plane of the crystal at right angles to the direction of wave propagation. At resonance an odd number of half wave lengths are contained in the thickness plane of the crystal blank. Therefore the thickness is the primary frequency determining dimension.

The AT-cut is commonly manufactured in the frequency ranges:

- 1 MHz ~ 32 MHz as Fundamental Mode
- 30 MHz ~ 250 MHz as Overtone Mode (3rd; 5th; 7th; 9th)

Below about 1 MHz the thickness shear mode resonators become too cumbersome and clumsy for general use and other modes of vibrations are used:

- below about 100 KHz Flexural Mode, Length Extensional Mode
- 100 KHz Face Shear Mode (CT-Cut; DT-Cut; SL-Cut)

For each mode of vibration there is an optimal angle of cut which controls the frequency deviation of the quartz crystal over the temperature range.

► Glossary & Terminology

- **Aging**

The frequency change of the crystal operated at specific conditions for a certain period of time.

- **AT-Cut**

A crystal cut, which the orientation of a synthetic quartz bar is set up at $35^{\circ}15'$ from the Z axis and its temperature characteristics show a cubic curve. The mode of vibration is thickness-shear.

- **Autoclave**

A sealed vessel made from special iron, that withstands high pressure and heat.

- **Base-Plating**

A process of applying coatings of metal layers on the surface of crystal wafers. There are two main methods: vacuum deposition and sputtering. The vacuum deposition melts metals in the chambers under a vacuum state. The sputtering method occurs by bombarding the surface of the sputtering target with gaseous ions.

- **BT-Cut**

A crystal cut, which the orientation of a synthetic quartz bar is set up at -49° from the Z axis and its temperature characteristics show a turnover curve. The mode of vibration is thickness-shear.

- **Bypass Capacitor**

A component required to lower the impedance of the power-supply system inserted between the power-supply pin and ground pin of the IC. Mount as closely as possible to the IC, using a bypass capacitor with a capacitance suitable for the oscillation frequency. (Example) KHz range $10\mu\text{F}$ to $100\mu\text{F}$ MHz range: $0.01\mu\text{F}$ to $0.1\mu\text{F}$

- **Crystal Resonators with Suppressed Fundamental Mode**

The crystals with suppressed fundamental mode are designed to suppress the fundamental oscillation of third overtone resonators to ensure proper overtone oscillation. These crystals enable the oscillation of overtone frequencies on a circuit without using a tuning coil. This has the beneficial effects of reducing the number of components in the circuit, reducing the need for trimming and miniaturization.

- **Equivalent Circuit**

The electrical equivalent circuit of a crystal resonator operating at its mechanical resonant frequency.

- **Frequency**

The number of recurrences of a periodic phenomenon (like radio wave or acoustic wave) per one second, often measured in Hertz (Hz).

Glossary Terminology of Ceramic Crystal Resonators

- **Frequency Characteristics over Temperature**
Allowable deviation of frequency at room temperature, in parts per million($\times 10^{-6}$). This is the maximum value within the operating temperature range.
- **Frequency Tolerance**
Allowable deviation from nominal at room temperature (25°C), indicated in parts per million ($\times 10^{-6}$).
- **Fundamental Crystal Resonators**
Crystal resonator designed to oscillate in the lowest-order (fundamental) oscillation mode.
- **Operating Temperature Range**
Temperature range over which the crystal resonator can be operated within allowable deviation range.
- **Overtone Crystal Resonators**
Crystal resonator designed to oscillate in the overtone oscillation mode (third, fifth, and seventh).
- **Q-Factor**
A value which indicates the sharpness of the peak resonance. A crystal has a small loss of vibration energy and high purity.
- **Reflow**
A soldering method which melts the solder paste being applied to the connection pads of the PCB (Printed Circuit Board) to mount electric components.
- **Sealing**
A process in which the package is tightly closed to be leak proof. This process is done under nitrogen gas atmosphere or vacuum state for the prevention of frequency stability degradation over time. There are two methods: seam-welding and glass-sealing.
- **Seed Quartz**
A highly pure crystal stick or a plate used as a crystal nucleus for growing synthetic quartz bars. This crystal stick/plate serves as the seed for the recrystallization process.

Ceramic Housed Crystal Resonators

**A New Ceramic Package Type Surface Mount
Crystal Resonator (TA7C/6C/5C/4C)**



www.token.com.tw

▶ Preview

Token Electronics offers two series Chip Ceramic Crystal Resonators in terms of TA*C series and TA*CA series. The TA*C series incorporates a sub-miniature AT-cut strip crystal resonator housed in a miniature 4.0×2.5×1.2mm ceramic package, while the TA*CA series incorporates a sub-miniature AT-cut strip crystal resonator housed in a miniature 2-pad 4.0×2.5mm ceramic package.

Both compact crystals chip components of TA*C series and TA*CA series are ideal for surface mount, densely-populated PCB applications.

Features

- Seam welded ceramic package, 1.2mm max. low profile.
- Ideally suit for disc driver, PCMCIA, PC and hand-held products.
- Tight stability, High reliability, Wide frequency range, High frequency.
- Rugged AT-cut crystal construction, Ultra miniature for maximum spacing saving.
- Tape and Reel packing method, Tight specifications available, RoHS Compliant.

Dimensions

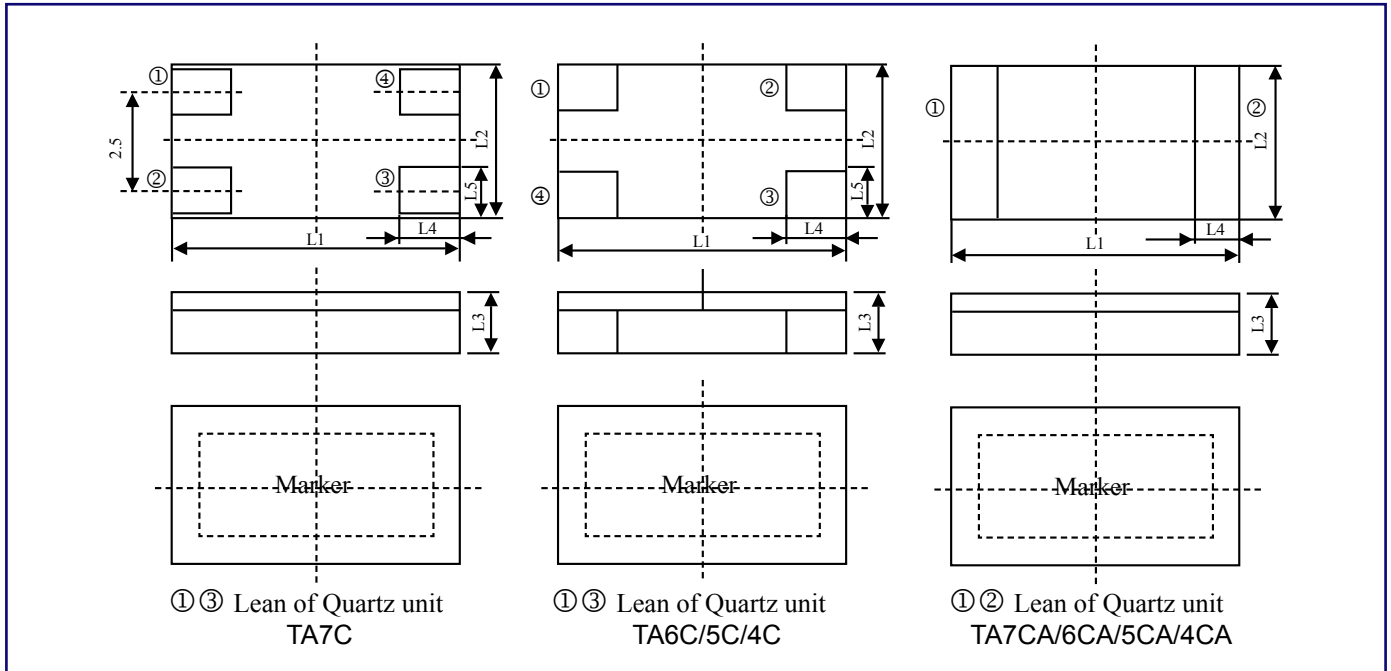

Part Number	Dimensions (unit: mm)								
	L1	L2	L3	L4	L5	L6	L7	L8	L9
TA4C TA4CA	4.0±0.3	2.5±0.3	1.2±0.2	1.2±0.2	0.9±0.2	4.2±0.2	2.7±0.2	1.4±0.2	1.1±0.2
TA5C TA5CA	5.0±0.3	3.2±0.3	1.2±0.2	1.4±0.2	1.0±0.2	5.2±0.2	3.4±0.2	1.6±0.2	1.2±0.2
TA6C TA6CA	6.0±0.3	3.5±0.3	1.2±0.2	1.5±0.2	1.2±0.2	6.2±0.2	3.7±0.2	1.8±0.2	1.4±0.2
TA7C TA7CA	7.0±0.3	5.0±0.3	1.2±0.2	1.5±0.2	1.2±0.2	8.0±0.2	3.9±0.2	2.2±0.2	1.4±0.2

Electrical Specifications

Part Number	Frequency Range (MHz)	Resonance Resistance (Ω) Max	Fundamental / Overtone	Adjustment Tolerance × 10 ⁻⁶	Temp.Range Tolerance Over × 10 ⁻⁶
TA4C TA4CA	12.000 ~ 19.999	80	Fund.	30	50
	20.000 ~ 25.999	70			
	26.000 ~ 36.000	50			
TA5C TA5CA	10.000 ~ 11.999	120			
	12.000 ~ 14.399	80			
	14.400 ~ 36.000	50			
TA6C TA6CA	8.000 ~ 11.999	80			
	12.000 ~ 16.000	60			
	16.001 ~ 40.000	40			
TA7C TA7CA	7.600 ~ 11.999	80			
	12.000 ~ 16.000	60			
	16.001 ~ 35.000	40			

▶ Recommended Land Pattern

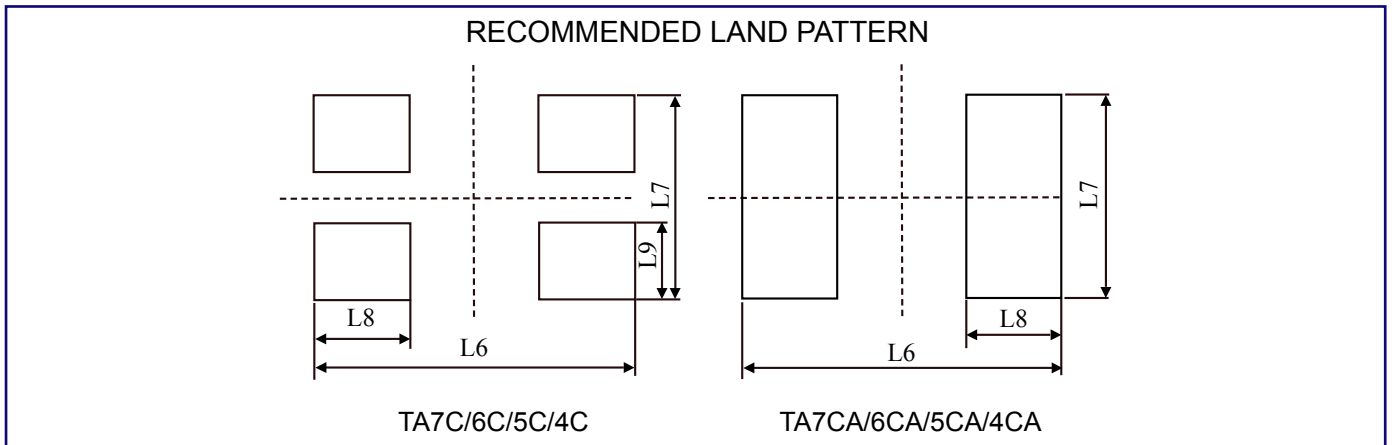

▶ Recommended Land Pattern

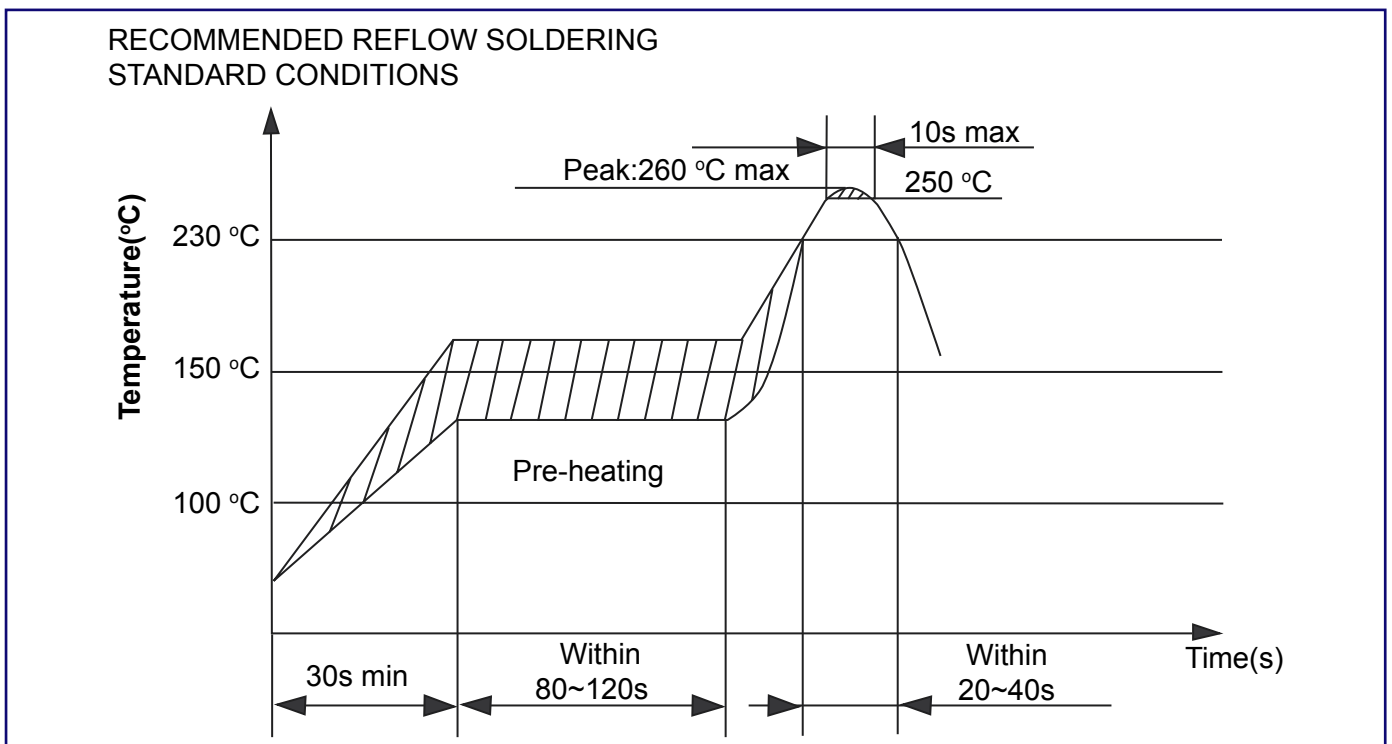

▶ Test Condition Of Peeling Strength

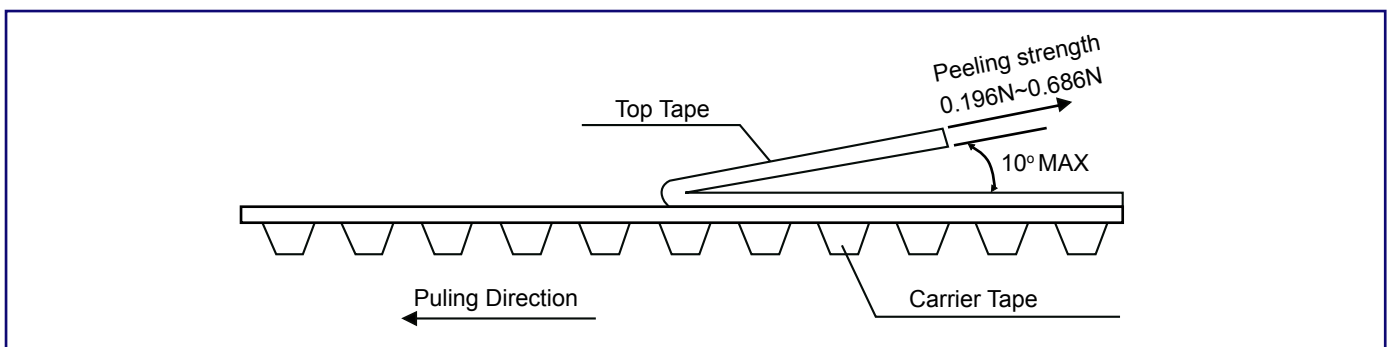

Packing Method

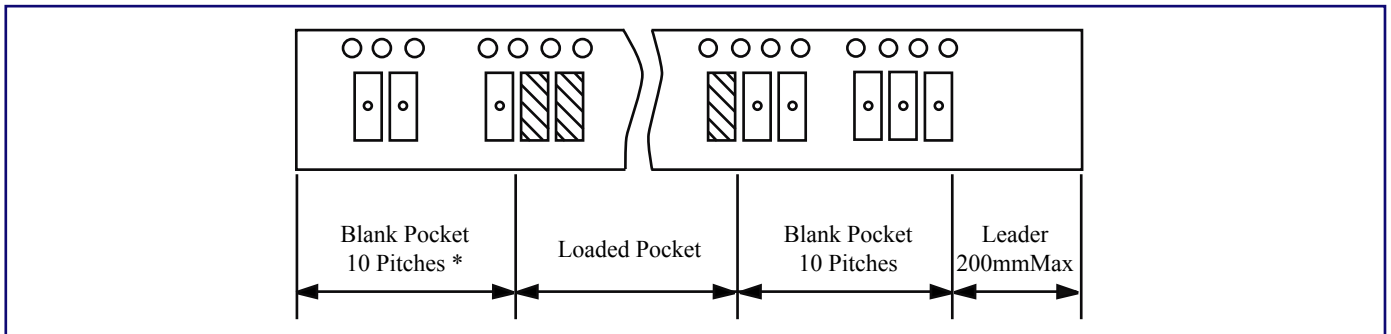

Reel Dimensions (Unit: mm)

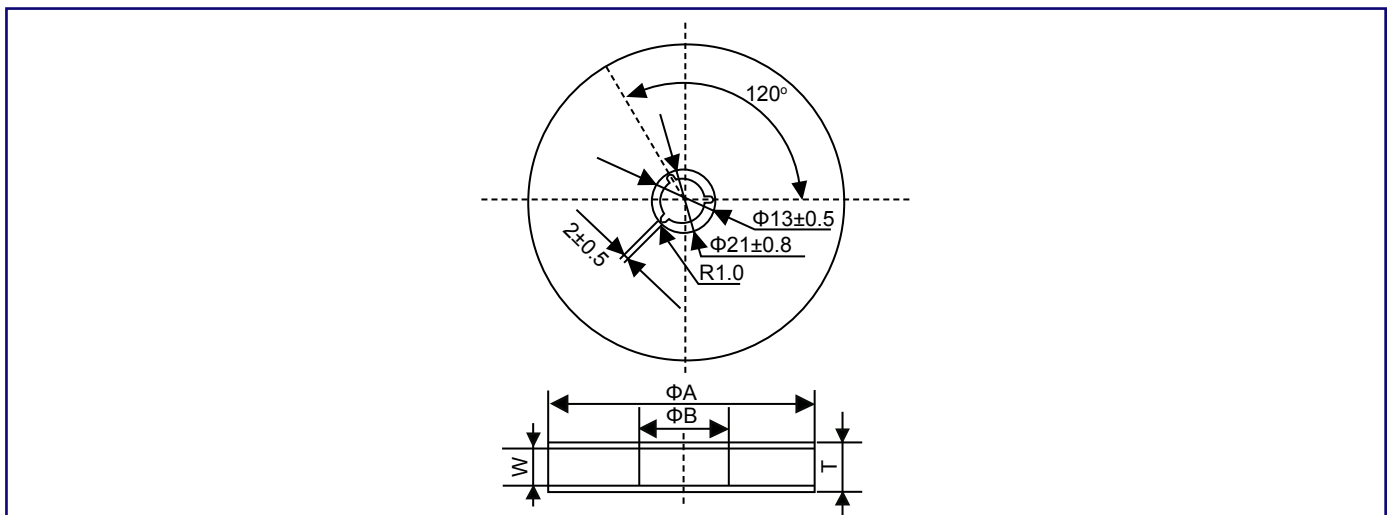

ΦA	ΦB	W	T	Pieces per reel	Carrier tape size
179 ± 2	60typ	12.4min	19.4max	3000typ	12
179 ± 2	60typ	16.4min	22.4max	1000typ	16
330 ± 3	80min	12.4min	19.4max	4000typ	12
330 ± 3	80min	16.4min	22.4max	4000typ	16
179 ± 2	60typ	8.4min	12.4max	3000typ	8

Note: typ : (Typical Value)

Carrier Tape Dimensions

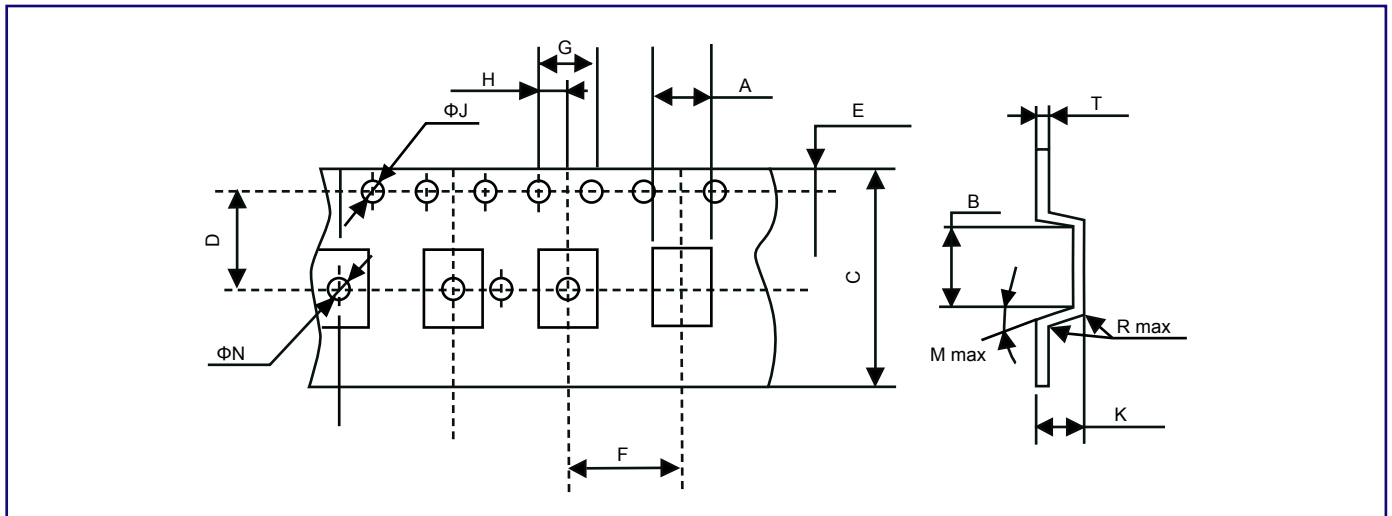

Part Number	Dimensions (unit: mm)													
	A	B	C	D	E	F	G	H	ΦJ	ΦN	Mmax	Rmax	K	T
TA4C TA4CA	2.9±0.2	4.4±0.2	12.0±0.2	5.5±0.1	1.75±0.1	4.0±0.1	4.0±0.1	2.0±0.1	1.5±0.1	1.6±0.1	10°	0.3	1.4±0.2	0.3±0.1
TA5C TA5CA	3.6±0.2	5.4±0.2	16.0±0.2	7.5±0.1	1.75±0.1	4.0±0.1	2.0±0.1	1.5±0.1	1.6±0.1	1.6±0.1	10°	0.3	1.4±0.2	0.3±0.1
TA6C TA6CA	3.9±0.2	6.4±0.2	16.0±0.2	7.5±0.1	1.75±0.1	4.0±0.1	2.0±0.1	1.5±0.1	1.6±0.1	1.6±0.1	10°	0.3	1.4±0.2	0.3±0.1
TA7C TA7CA	5.4±0.2	7.4±0.2	16.0±0.2	7.5±0.1	1.75±0.1	4.0±0.1	2.0±0.1	1.5±0.1	1.6±0.1	1.6±0.1	10°	0.3	1.4±0.2	0.3±0.1

How to Order

TA6C

❶

12.000M

❷

TR

❸

❶ Part Number

❷ Frequency (MHz)

❸ Package:

Code	Package
T	Taping Reel
P	Bulk

Back to 1st Page - Ceramic Surface Mount Crystal Resonator (TA7C/6C/5C/4C)