

Headphone amplifier with internal LPF and EVR for CD-ROM

BA3530FS

The BA3530FS is an H/P amplifier with internal secondary LPF and EVR circuits. When multibit output from a D/A converter is input, the secondary LPF outputs an audio signal. The amplifier circuit allows for line output and headphone output. The output level for headphones can be changed with the EVR circuit. This IC also has independent internal mute circuits for the left and right channels.

● Applications

CD-ROM drives and other products (with line and headphone output pins) that process digital audio signals

● Features

- 1) Internal LPF, line amplifier and EVR.
- 2) Internal mute function.
- 3) Internal thermal shutdown circuit.
- 4) No attached components are needed for oscillation prevention, even at a load of 8 Ω .
- 5) Mute function reduces the popping noises that can occur when the power is turned on and off.

● Absolute maximum ratings (Ta=25°C)

Parameter	Symbol	Limits	Unit
Power supply voltage	Vcc	6.5	V
Power dissipation	Pd	500 *	mW
Operating temperature	Topr	-10~75	°C
Storage temperature	Tstg	-55~125	°C

* Reduced by 5.0 mW for each increase in Ta of 1°C over 25°C.

● Recommended operating conditions

Parameter	Symbol	Min.	Typ.	Max.	Unit
Power supply voltage	Vcc	4.5	—	5.5	V

7828999 0017808 108

● Block diagram

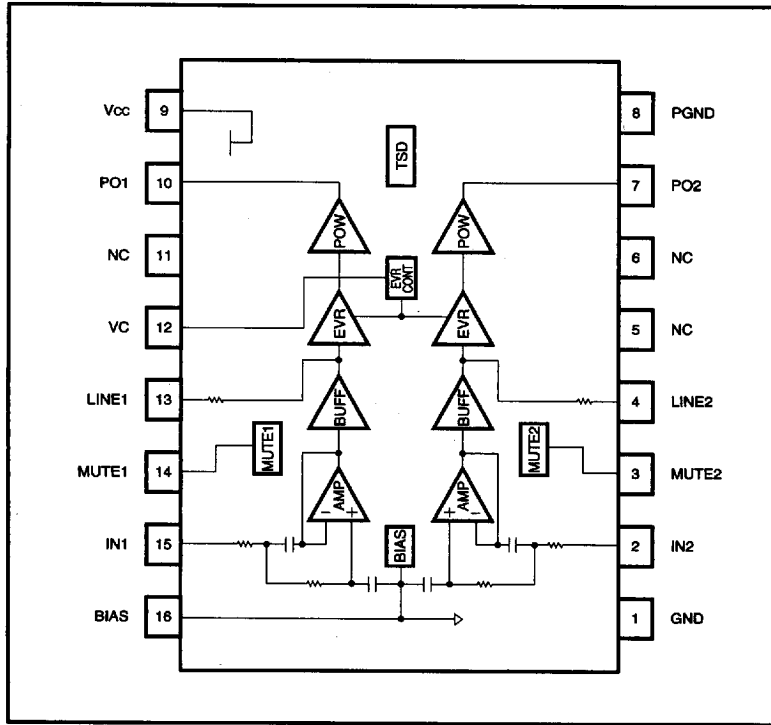

Headphone Amplifiers for CD-ROM

For CDs/CD-ROMs

7828999 0017809 044

ROHM

- Electrical characteristics (unless otherwise noted, $T_a=25^\circ\text{C}$, $V_{CC}=5.0\text{V}$, line $R_{L1}=50\text{k}\Omega$, H/P $R_{L2}=32\Omega$, $V_{IN}=0.8\text{V}_{\text{rms}}$, $f=1\text{kHz}$, EVR Max.)

Parameter	Symbol	Min.	Typ.	Max.	Unit	Conditions
Quiescent current	I_Q	6	11	18	mA	$V_{IN}=0\text{V}_{\text{rms}}$
Mute pin threshold voltage	V_{TM}	0.3	1.0	1.6	V	MUTE1, 2
〈Line out〉						
Voltage gain 1	G_{VCL1}	-1.0	0.0	0.5	dB	
Voltage gain 2	G_{VCL2}	-1.5	0.0	0.5	dB	$f=20\text{kHz}$
Interchannel gain differential	ΔG_{VCL}	-0.5	0	0.5	dB	
Total harmonic distortion	THDL	—	0.03	0.1	%	$BW=20\sim 20\text{kHz}$
Maximum output voltage	V_{OML}	0.7	0.8	0.9	V_{rms}	THD<0.1%
Output noise voltage	V_{NOL}	—	-95	-85	dBV	$BW=20\sim 20\text{kHz}$, input = open
Channel separation	CSL	60	65	—	dB	
Mute attenuation	ATTL	65	75	—	dB	Single channel input
Ripple rejection	RRL	50	55	—	dB	$f_{RR}=100\text{Hz}$, $V_{RR}=-20\text{dBV}$
〈Headphone amplifier〉						
Voltage gain	G_{VCL}	-1.5	0.0	1.0	dB	
Interchannel gain differential	ΔG_{VC}	-0.5	0	0.5	dB	
Total harmonic distortion	THDH	—	0.04	0.1	%	$BW=20\sim 20\text{kHz}$
Rated output 1	P_{O1}	14	20	25	mW	$R_L=32\Omega$, THD<0.1%
Rated output 2	P_{O2}	28	40	50	mW	$R_L=16\Omega$, THD<0.1%
Output noise voltage	V_{NOH}	—	-85	-80	dBV	$BW=20\sim 20\text{kHz}$, input = open
Channel Separation	CSH	70	75	—	dB	
Mute attenuation	ATTH	85	90	—	dB	Single channel input
Ripple rejection	RRH	45	50	—	dB	$f_{RR}=100\text{Hz}$, $V_{RR}=-20\text{dBV}$
EVR attenuation	ATT	65	75	—	dB	EVR=Max.~Min.

7828999 0017810 866

● Measurement circuit

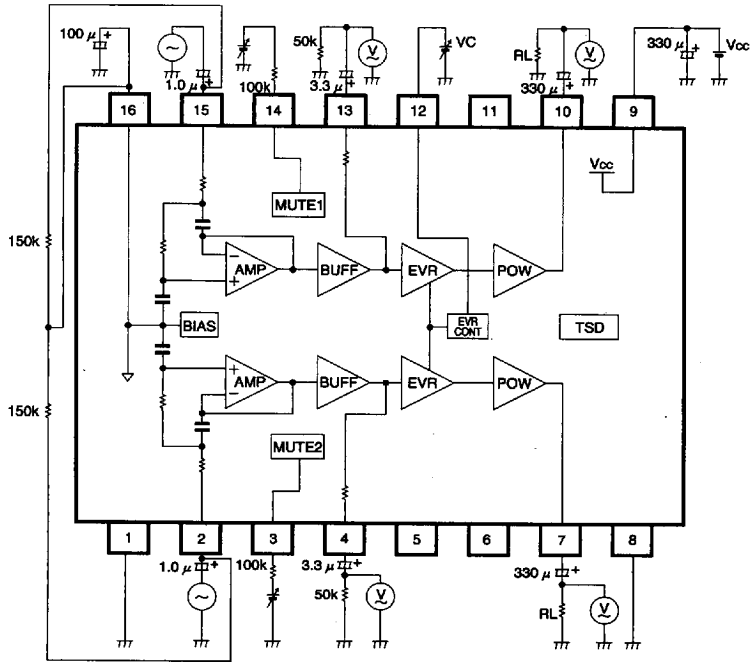

Fig. 1

Headphone Amplifiers for CD-ROM

For CDs/CD-ROMs

7828999 0017811 7T2

ROHM

● Application example

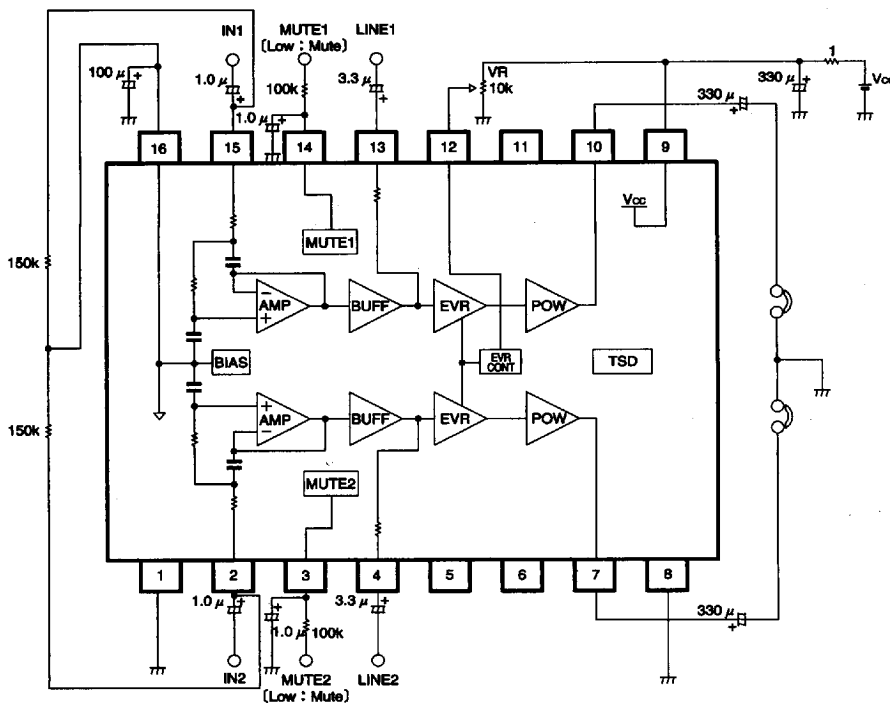

Fig. 2

7828999 0017812 639

● Operation notes

1. Preventing popping noises

The BA3530FS has a mute function that reduces the popping noises that can occur when the power is turned on or off. The popping noises that occur when the muting function turns on and off can be reduced by attaching a capacitor and resistor to the mute pins (pins 3 and 14).

2. Recommended time chart

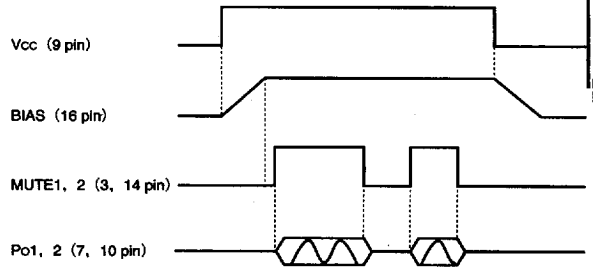

Fig. 3

● Electrical characteristic curves

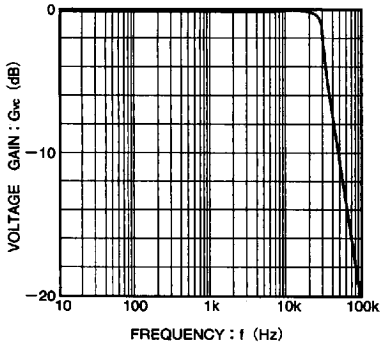

Fig. 4 Voltage gain vs. frequency characteristics

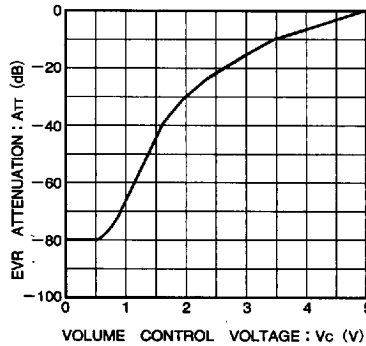
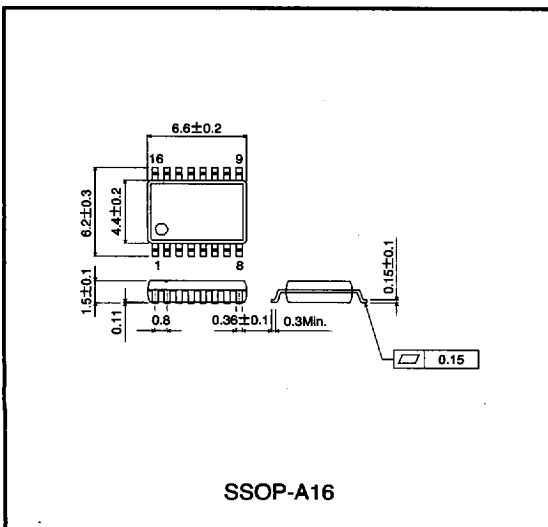

Fig. 5 EVR attenuation characteristic

● External dimensions (Units: mm)



SSOP-A16

7828999 0017813 575

