

FEATURES

- InGaP HBT Technology
- High Efficiency:
 39%, $V_{MODE} = 0\text{ V}$
 40%, $V_{MODE} = +2.85\text{ V}$ (no mode switching)
- Low Quiescent Current: 50 mA
- Low Leakage Current in Shutdown Mode: $<1\ \mu\text{A}$
- $V_{REF} = +2.85\text{ V}$ (+2.75 V min over temp)
- Optimized for a 50 Ω System
- Low Profile Miniature Surface Mount Package:
 1.1 mm
- CDMA 1XRTT, 1xEV-DO Compliant
- Pinout Enables Easy Phone Board Migration
 From 4 mm x 4 mm Package
- RoHS-Compliant Package, 250 °C MSL-3

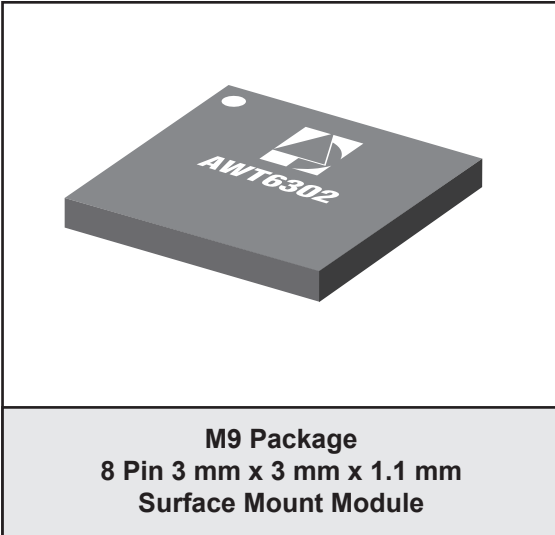

APPLICATIONS

- CDMA/EVDO PCS-band Wireless Handsets and Data Devices

PRODUCT DESCRIPTION

The AWT6302R meets the increasing demands for higher efficiency and linearity in CDMA 1X handsets, while reducing pcb area by 44%. The package pinout was chosen to enable handset manufacturers to switch from a 4 mm x 4 mm PA module with very few layout changes to the phone board. The PA module is optimized for $V_{REF} = +2.85\text{ V}$. The device is manufactured on an advanced InGaP HBT MMIC technology offering state-of-the-art reliability, temperature stability, and

ruggedness. Selectable bias modes that optimize efficiency for different output power levels, and a shutdown mode with low leakage current, increase handset talk and standby time. The self-contained 3 mm x 3 mm x 1.1 mm surface mount package incorporates matching networks optimized for output power, efficiency, and linearity in a 50 Ω system.

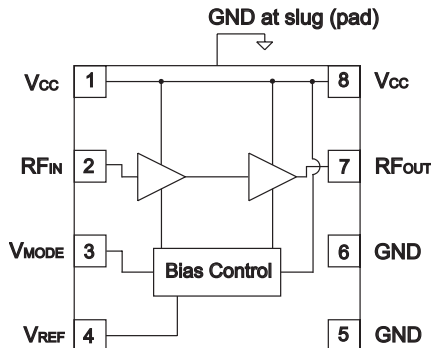

Figure 1: Block Diagram

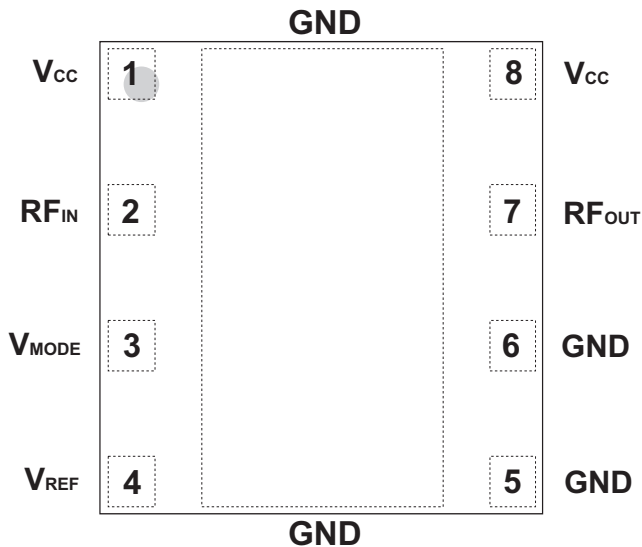

Figure 2: Pinout (X-ray Top View)

Table 1: Pin Description

PIN	NAME	DESCRIPTION
1	V _{CC}	Supply Voltage
2	RF _{IN}	RF Input
3	V _{MODE}	Mode Control Voltage
4	V _{REF}	Reference Voltage
5	GND	Ground
6	GND	Ground
7	RF _{OUT}	RF Output
8	V _{CC}	Supply Voltage

ELECTRICAL CHARACTERISTICS

Table 2: Absolute Minimum and Maximum Ratings

PARAMETER	MIN	MAX	UNIT
Supply Voltage (V_{CC})	0	+5	V
Mode Control Voltage (V_{MODE})	0	+3.5	V
Reference Voltage (V_{REF})	0	+3.5	V
RF Input Power (P_{IN})	-	+10	dBm
Storage Temperature (T_{STG})	-40	+150	°C

Stresses in excess of the absolute ratings may cause permanent damage. Functional operation is not implied under these conditions. Exposure to absolute ratings for extended periods of time may adversely affect reliability.

Table 3: Operating Ranges

PARAMETER	MIN	TYP	MAX	UNIT	COMMENTS
Operating Frequency (f)	1850	-	1910	MHz	
Supply Voltage (V_{CC})	+3.2	+3.4	+4.2	V	
Reference Voltage (V_{REF})	+2.75 0	+2.85 -	+3.1 +0.5	V	PA "on" PA "shut down"
Mode Control Voltage (V_{MODE})	+2.5 0	+2.85 -	+3.1 +0.5	V	Low Bias Mode High Bias Mode
RF Output Power (P_{OUT})	27.5 ⁽¹⁾	+28.0	-	dBm	
Case Temperature (T_C)	-30	-	+85	°C	

The device may be operated safely over these conditions; however, parametric performance is guaranteed only over the conditions defined in the electrical specifications.

Notes:

(1) For operation at $V_{CC} = +3.2$ V, P_{OUT} is derated by 0.5 dB.

Table 4: Electrical Specifications
 (T_C = +25 °C, V_{CC} = +3.4 V, V_{REF} = +2.85 V, 50 Ω system)

PARAMETER	MIN	TYP	MAX	UNIT	COMMENTS
Gain	24.5 22	26.5 24.5	29 27	dB	P _{OUT} = +28 dBm, V _{MODE} = 0 V P _{OUT} = +16 dBm, V _{MODE} = +2.85 V
Adjacent Channel Power at +1.25 MHz offset Primary Channel BW =1.23 MHz Adjacent Channel BW = 30 kHz	- -	-51 -51	-47 -47	dBc	P _{OUT} = +28 dBm, V _{MODE} = 0 V P _{OUT} = +16 dBm, V _{MODE} = +2.85 V
Adjacent Channel Power at +2.25 MHz offset Primary Channel BW =1.23 MHz Adjacent Channel BW = 30 kHz	- -	-63 -69	-57 -57	dBc	P _{OUT} = +28 dBm, V _{MODE} = 0 V P _{OUT} = +16 dBm, V _{MODE} = +2.85 V
Power-Added Efficiency	37 8.3	39 9	- -	%	P _{OUT} = +28 dBm, V _{MODE} = 0 V P _{OUT} = +16 dBm, V _{MODE} = +2.85 V
Quiescent Current (I _q)	-	50	62	mA	V _{MODE} = +2.85 V
Reference Current	-	2.3	4	mA	through V _{REF} pin, PA "on"
Mode Control Current	-	0.3	1.0	mA	through V _{MODE} pin, V _{MODE} = +2.85 V
Leakage Current	-	<1	5	μA	V _{CC} = +4.2 V, V _{REF} = 0 V, V _{MODE} = 0 V
Noise in Receive Band	-	-132	-130	dBm/Hz	1930 MHz to 1990 MHz
Harmonics 2fo 3fo, 4fo	- -	-40 -55	-30 -30	dBc	
Input Impedance	-	-	2.5:1	VSWR	
Spurious Output Level (all spurious outputs)	-	-	-65	dBc	P _{OUT} ≤ +28 dBm In-band load VSWR < 5:1 Out-of-band load VSWR < 10:1 Applies over all operating ranges
Load mismatch stress with no permanent degradation or failure	8:1	-	-	VSWR	Applies over full operating range

Notes:

1. ACPRs and Efficiency Limits at mid-band only.

Table 5: Electrical Specifications
 ($T_C = +25\text{ }^\circ\text{C}$, $V_{CC} = +3.4\text{ V}$, $V_{REF} = +2.85\text{ V}$, $V_{MODE} = +2.85\text{ V}$, $50\text{ }\Omega$ system)

PARAMETER	MIN	TYP	MAX	UNIT	COMMENTS
Gain	24 22	26 24.5	28 27	dB	$P_{OUT} = +28\text{ dBm}$ $P_{OUT} = +16\text{ dBm}$
Adjacent Channel Power at $\pm 1.25\text{ MHz}$ offset Primary Channel BW - 1.23 MHz Adjacent Channel BW = 30 kHz	- -	-52 -51	-47 -47	dBc	$P_{OUT} = +28\text{ dBm}$ $P_{OUT} = +16\text{ dBm}$
Adjacent Channel Power at $\pm 2.25\text{ MHz}$ offset Primary Channel BW - 1.23 MHz Adjacent Channel BW = 30 kHz	- -	-61 -69	-57 -57	dBc	$P_{OUT} = +28\text{ dBm}$ $P_{OUT} = +16\text{ dBm}$
Power-Added Efficiency	37 8.3	40 9	- -	%	$P_{OUT} = +28\text{ dBm}$ $P_{OUT} = +16\text{ dBm}$
Quiescent Current (I_{cq})	-	48	62	mA	$V_{MODE} = +2.85\text{ V}$
Reference Current	-	2.3	4	mA	through V_{REF} pin, PA "on"
Mode Control Current	-	0.3	1.0	mA	through V_{MODE} pin
Leakage Current	-	<1	5	μA	$V_{CC} = +4.2\text{ V}$, $V_{REF} = 0\text{ V}$, $V_{MODE} = 0\text{ V}$
Noise in Receive Band	-	-132	-130	dBm/Hz	1930 MHz to 1990 MHz
Harmonics 2fo 3fo, 4fo	- -	-40 -55	-30 -30	dBc	
Input Impedance	-	-	2.5:1	VSWR	
Spurious Output Level (all spurious outputs)	-	-	-65	dBc	$P_{OUT} \leq +28\text{ dBm}$ In-band load VSWR < 5:1 Out-of-band load VSWR < 10:1 Applies over all operating ranges
Load mismatch stress with no permanent degradation or failure	8:1	-	-	VSWR	Applies over full operating range

Notes:

1. ACPRs and Efficiency Limits at mid-band only.

APPLICATION INFORMATION

To ensure proper performance, refer to all related Application Notes on the ANADIGICS web site: <http://www.anadigics.com>

Shutdown Mode

The power amplifier may be placed in a shutdown mode by applying logic low levels (see Operating Ranges table) to both the V_{REF} and V_{MODE} voltages.

Bias Modes

The power amplifier may be placed in either a Low Bias mode or a High Bias mode by applying the appropriate logic level (see Operating Ranges table) to the V_{MODE} voltage. The Bias Control table lists the recommended modes of operation for various applications.

Table 6: Bias Control

APPLICATION	P_{OUT} LEVELS	BIAS MODE	V_{REF}	V_{MODE}
CDMA - low power	$\leq +16\text{dBm}$	Low	+2.85 V	+2.85 V
CDMA - high power	$> +16\text{ dBm}$	High	+2.85 V	0 V
Shutdown	-	Shutdown	0 V	0 V

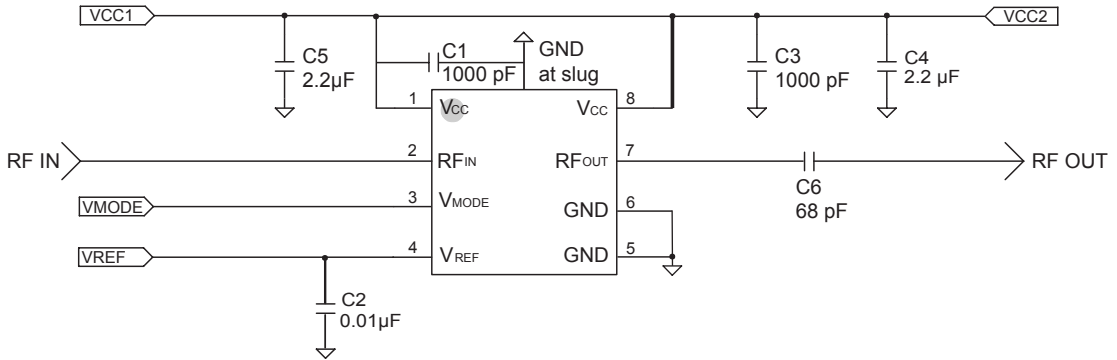
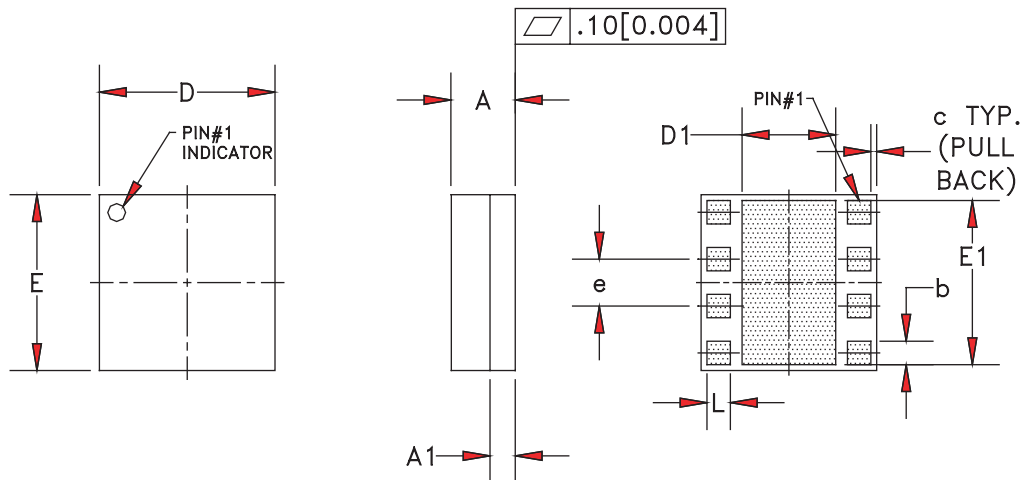

Figure 3: Application Circuit

PACKAGE OUTLINE



Symbol	MILLIMETERS			INCHES			NOTE
	MIN.	NOM.	MAX.	MIN.	NOM.	MAX.	
A	1.07	1.17	1.27	0.042	0.046	0.05	—
A1	—	0.51	—	—	0.020	—	—
b	0.35	—	0.60	0.013	—	0.024	3
c	—	0.10	—	—	0.004	—	—
D	2.88	3.00	3.12	0.113	0.118	0.123	—
D1	1.20	—	1.50	0.047	—	0.060	3
E	2.88	3.00	3.12	0.113	0.118	0.123	—
E1	2.75	—	2.85	0.108	—	0.112	3
e	0.80 BSC			0.0315 BSC			—
L	0.35	—	0.60	0.013	—	0.024	3

NOTES:

1. CONTROLLING DIMENSIONS: MILLIMETERS
2. UNLESS SPECIFIED TOLERANCE=±0.076[0.003].
3. PADS (INCLUDING CENTER) SHOWN UNIFORM SIZE FOR REFERENCE ONLY. ACTUAL PAD SIZE AND LOCATION WILL VARY WITHIN MIN. AND MAX. DIMENSIONS ACCORDING TO SPECIFIC LAMINATE DESIGN.
4. UNLESS SPECIFIED DIMENSIONS ARE SYMMETRICAL ABOUT CENTER LINES SHOWN.

Figure 4: M9 Package Outline - 8 Pin 3 mm x 3 mm x 1.1 mm Surface Mount Module

TOP BRAND



NOTES:

1. ANADIGICS LOGO SIZE: NONE
2. PART NUMBER: FOUR DIGIT NUMERICAL
3. WAFER LOT NUMBER: LLLL = LOT NUMBER
NN = WAFER I.D.
4. PIN 1 INDICATOR: LASER DOT
5. B.O.M. #: BBBB
6. COUNTRY CODE: CC = TH-for-THAILAND, TW-for-TAIWAN
CC = PH-for-PHILIPPINES, CH-for-CHINA
7. TYPE : ARIAL
SIZE : 1.5-POINT
COLOR : LASER

Figure 5: Branding Specification

COMPONENT PACKAGING

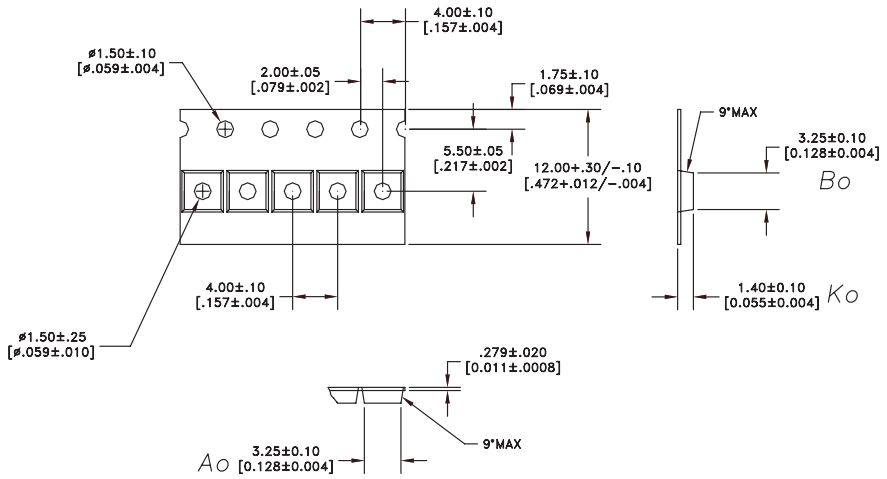

NOTES:

1. MATERIAL: 3000 (CARBON FILLED POLYCARBONATE)
100% RECYCLABLE.

DIMENSIONS ARE IN MILLIMETERS [INCHES]

DIMENSIONING AND TOLERANCING PER ASME Y14.5M-1994

Figure 6: Tape & Reel Packaging

Table 7: Tape & Reel Dimensions

PACKAGE TYPE	TAPE WIDTH	POCKET PITCH	REEL CAPACITY	MAX REEL DIA
3 mm x 3 mm x 1 mm	12 mm	4 mm	2500	7"

NOTES

ORDERING INFORMATION

ORDER NUMBER	TEMPERATURE RANGE	PACKAGE DESCRIPTION	COMPONENT PACKAGING
AWT6302RM9Q7	-30 °C to +85 °C	RoHS-Compliant 8 Pin 3 mm x 3 mm x 1 mm Surface Mount Module	Tape and Reel, 2500 pieces per Reel



ANADIGICS, Inc.
 141 Mount Bethel Road
 Warren, New Jersey 07059, U.S.A.
 Tel: +1 (908) 668-5000
 Fax: +1 (908) 668-5132

URL: <http://www.anadigics.com>
 E-mail: Mktg@anadigics.com

IMPORTANT NOTICE

ANADIGICS, Inc. reserves the right to make changes to its products or to discontinue any product at any time without notice. The product specifications contained in Advanced Product Information sheets and Preliminary Data Sheets are subject to change prior to a product's formal introduction. Information in Data Sheets have been carefully checked and are assumed to be reliable; however, ANADIGICS assumes no responsibilities for inaccuracies. ANADIGICS strongly urges customers to verify that the information they are using is current before placing orders.

WARNING

ANADIGICS products are not intended for use in life support appliances, devices or systems. Use of an ANADIGICS product in any such application without written consent is prohibited.