

PLEASE CHECK WWW.MOLEX.COM FOR LATEST PART INFORMATION

Part Number: [0191930261](#)
Status: **Active**
Description: VersaKrimp™ Ring Tongue Terminal for 4 AWG Wire

Documents:

[Drawing \(PDF\)](#) [RoHS Certificate of Compliance \(PDF\)](#)

Agency Certification

CSA LR18689
 UL E32244

General

Product Family Ring and Spade Terminals
 Series [19193](#)
 Crimp Quality Equipment Yes
 Mil-Spec N/A
 Product Name VersaKrimp™
 Type Ring

Physical

Barrel Type Closed - Brazed
 Insulation None
 Material - Plating Mating Tin
 Packaging Type Bag
 Plating min: Mating (µin) 100
 Plating min: Mating (µm) 2.5
 Plating min: Termination (µin) 100
 Plating min: Termination (µm) 2.5
 Stud Size 1/4" (M6)
 Termination Interface: Style Crimp or Compression
 Wire Size AWG 4

Material Info

Old Part Number F-366-14

Reference - Drawing Numbers

Sales Drawing SD-19193-006

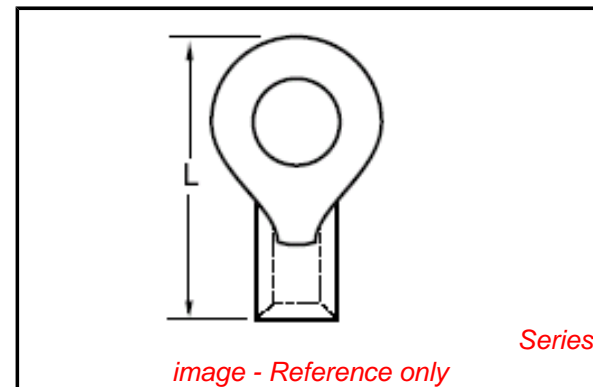

EU RoHS

ELV and RoHS Compliant
REACH SVHC Contains SVHC: No
Halogen-Free Status

China RoHS



Need more information on product environmental compliance?

Email productcompliance@molex.com
 For a multiple part number RoHS Certificate of Compliance, [click here](#)

Please visit the [Contact Us](#) section for any non-product compliance questions.

Search Parts in this Series

[19193Series](#)

Application Tooling | [FAQ](#)

Tooling specifications and manuals are found by selecting the products below. Crimp Height Specifications are then contained in the Application Tooling Specification document.

Global

Description	Product #
Putt Pump Dieless Head System	0192860065
Manual tool for Crimping non-insulated 8AWG thru 4/0 Terminals	0192940008
Manual Putt Pump Hydraulic System, Die set required	0192860117
Die Set (large) for the HHLS Hydraulic Crimper	0192900007
Hand Crimp Tool	0640013900

This document was generated on 04/14/2010

PLEASE CHECK WWW.MOLEX.COM FOR LATEST PART INFORMATION

Customer Dwg:

MATERIAL: Copper
 PLATING: Electro-Tin
 STUD SIZE: "D" ±.005

- 10 - .198
- 14 - .265
- 56 - .328
- 38 - .390
- 76 - .453
- 12 - .515
- 58 - .656
- 34 - .781
- 209 = .209
- 413 = .413

VERSAKRIMP

BRAZE SEAM

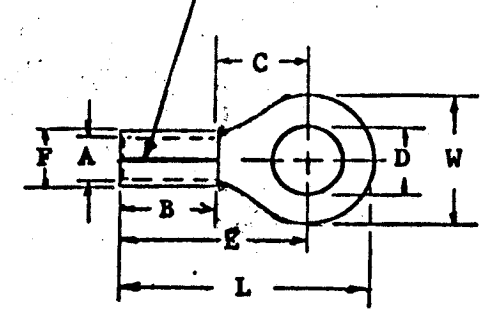

Customer Dimensions

Part No.	Wire Size	"W"	"C" Min	"E" Max	"B" Min	"L" Max	"A" Min	Stock Thkns. (A)	"F" Max	AVAILABLE STUD SIZE
F-366-	#4	.652 .678	.520	1.028	.425	1.385	.280	REF. .075	.470	209, 413 10, 14, 56, 38, 76, 12,
F-367-	#4	.465 .485	.520	1.028	.425	1.288	.280	REF. .075	.470	10, 14, 56
F-369-	#4	.875 .895	.989	1.497	.425	1.970	.280	REF. .075	.470	14, 56, 38, 76, 12, 58
F-370-	#4	1.250 1.270	.989	1.497	.425	2.158	.280	REF. .075	.470	14, 56, 38, 76, 12, 58, 34

For parts to be on tape add "T" at end of part number.



TITLE: "F" RING TONGUE TERMINAL

DIMENSIONAL TOLERANCE UNLESS OTHERWISE SPECIFIED		
FRAC.	DEC.	ANG.
±	±	±

REVISION	SCALE: NONE	DATE
	DRWN. BY: LEM	3/2/70
	CHKD. BY:	
	APPRD. BY:	
A	ETC 50245 11/2 RGM	DRAWING NO.: