

## Optocoupler with Phototransistor Output

### Features

- CTR offered in 9 Groups
- Isolation materials according to UL94-VO
- Pollution degree 2 (DIN/VDE 0110 / resp. IEC 664)
- Climatic classification 55/100/21 (IEC 68 part 1)
- Special construction: Therefore, extra low coupling capacity of typical 0.2 pF, high **Common Mode Rejection**
- Low temperature coefficient of CTR
- Temperature range - 40 to + 110 °C
- Coupling System U
- Rated impulse voltage (transient overvoltage)  $V_{IOTM} = 8 \text{ kV}_{peak}$
- Isolation test voltage (partial discharge test voltage)  $V_{pd} = 1.6 \text{ kV}$
- Rated isolation voltage (RMS includes DC)  $V_{IOWM} = 600 \text{ V}_{RMS} (848 \text{ V}_{peak})$
- Rated recurring peak voltage (repetitive)  $V_{IORM} = 600 \text{ V}_{RMS}$
- Creepage current resistance according to VDE 0303/IEC 112 **Comparative Tracking Index: CTI**  $\geq 175$
- Thickness through insulation  $\geq 0.75 \text{ mm}$
- Internal creepage distance  $> 4 \text{ mm}$
- External creepage distance  $> 8 \text{ mm}$

### Agency Approvals

- BSI: EN 60065:2002, EN 60950:2000 Certificate number 7081 and 7402
- FIMKO (SETI): EN 60950:2000 Certificate number FI 18973
- Underwriters Laboratory (UL) File number E 76222
- VDE IEC 60747 Certificate number 115667

### Applications

Circuits for safe protective separation against electrical shock according to safety class II (reinforced isolation):

- For appl. class I - IV at mains voltage  $\leq 300 \text{ V}$

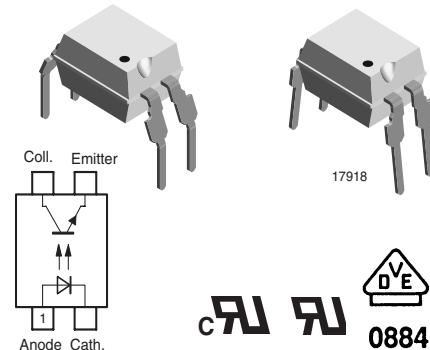

- For appl. class I - III at mains voltage  $\leq 600 \text{ V}$  according to VDE 0884, table 2, suitable for:

**Switch-mode power supplies, line receiver, computer peripheral interface, microprocessor system interface, with operating temperature up to 110°C**

### Description

The TCET111.(G) consists of a phototransistor optically coupled to a gallium arsenide infrared-emitting diode in a 4-lead plastic dual in-line package.

The elements are mounted on one lead frame using a **coplanar technique**, providing a fixed distance between input and output for highest safety requirements.

### VDE Standards

These couplers perform safety functions according to the following equipment standards:

#### VDE 0884 / IEC 60747:2003

Optocoupler for electrical safety requirements

#### IEC 60950

Office machines (applied for reinforced isolation for mains voltage  $< 400 \text{ V}_{RMS}$ )

#### VDE 0804

Telecommunication apparatus and data processing

#### IEC 60065

Safety for mains-operated electronic and related household apparatus

### Order Information

Part	Remarks
TCET1110 (G)	50 to 600 %
TCET1111 (G)	40 to 80 %
TCET1112 (G)	63 to 125 %
TCET1113 (G)	100 to 200 %
TCET1114 (G)	160 to 320 %
TCET1115 (G)	50 to 150 %
TCET1116 (G)	100 to 300 %
TCET1117 (G)	80 to 160 %
TCET1118 (G)	130 to 260 %
TCET1119 (G)	200 to 400 %

G = Lead form 10.16 mm; G is not marked on the body,

4 Pin = Single Channel

### Absolute Maximum Ratings

$T_{amb} = 25\text{ }^{\circ}\text{C}$ , unless otherwise specified

Stresses in excess of the absolute Maximum Ratings can cause permanent damage to the device. Functional operation of the device is not implied at these or any other conditions in excess of those given in the operational sections of this document. Exposure to absolute Maximum Rating for extended periods of the time can adversely affect reliability.

### Emitter

Parameter	Test condition	Symbol	Value	Unit
Reverse voltage		$V_R$	6	V
Forward current		$I_F$	60	mA
Forward surge current	$t_p \leq 10\text{ }\mu\text{s}$	$I_{FSM}$	1.5	A
Power dissipation		$P_{Diss}$	100	mW
Junction temperature		$T_j$	125	$^{\circ}\text{C}$

### Detector

Parameter	Test condition	Symbol	Value	Unit
Collector emitter voltage		$V_{CEO}$	70	V
Emitter collector voltage		$V_{ECO}$	7	V
Collector current		$I_C$	50	mA
Collector peak current	$t_p/T = 0.5, t_p \leq 10\text{ ms}$	$I_{CM}$	100	mA
Power dissipation		$P_{Diss}$	150	mW
Junction temperature		$T_j$	125	$^{\circ}\text{C}$

### Coupler

Parameter	Test condition	Symbol	Value	Unit
Isolation test voltage (RMS)	$t = 1\text{ min}$	$V_{IO}$	5	kV
Total power dissipation		$P_{tot}$	250	mW
Operating ambient temperature range		$T_{amb}$	- 40 to + 110	$^{\circ}\text{C}$
Storage temperature range		$T_{stg}$	- 55 to + 125	$^{\circ}\text{C}$
Soldering temperature	2 mm from case $t \leq 10\text{ s}$	$T_{sd}$	260	$^{\circ}\text{C}$



### Electrical Characteristics

T<sub>amb</sub> = 25 °C, unless otherwise specified

Minimum and maximum values are testing requirements. Typical values are characteristics of the device and are the result of engineering evaluation. Typical values are for information only and are not part of the testing requirements.

### Emitter

Parameter	Test condition	Symbol	Typ.	Max	Unit
Forward voltage	I <sub>F</sub> = ± 50 mA	V <sub>F</sub>	1.25	1.6	V
Junction capacitance	V <sub>R</sub> = 0 V, f = 1 MHz	C <sub>j</sub>	50		pF

### Detector

Parameter	Test condition	Symbol	Min	Typ.	Max	Unit
Collector emitter voltage	I <sub>C</sub> = 1 mA	V <sub>CEO</sub>	70			V
Emitter collector voltage	I <sub>E</sub> = 100 μA	V <sub>ECO</sub>	7			V
Collector emitter cut-off current	V <sub>CE</sub> = 20 V, I <sub>F</sub> = 0, E = 0	I <sub>CEO</sub>		10	100	nA

### Coupler

Parameter	Test condition	Symbol	Typ.	Max	Unit
Collector emitter saturation voltage	I <sub>F</sub> = 10 mA, I <sub>C</sub> = 1 mA	V <sub>CEsat</sub>		0.3	V
Cut-off frequency	V <sub>CE</sub> = 5 V, I <sub>F</sub> = 10 mA, R <sub>L</sub> = 100 Ω	f <sub>c</sub>	110		kHz
Coupling capacitance	f = 1 MHz	C <sub>k</sub>	0.3		pF

### Current Transfer Ratio

Parameter	Test condition	Part	Symbol	Min	Typ.	Max	Unit
I <sub>C</sub> /I <sub>F</sub>	V <sub>CE</sub> = 5 V, I <sub>F</sub> = 1 mA	TCET1111 (G)	CTR	0.13	0.30		%
	V <sub>CE</sub> = 5 V, I <sub>F</sub> = 1 mA	TCET1112 (G)	CTR	0.22	0.45		%
	V <sub>CE</sub> = 5 V, I <sub>F</sub> = 1 mA	TCET1113 (G)	CTR	0.34	0.70		%
	V <sub>CE</sub> = 5 V, I <sub>F</sub> = 1 mA	TCET1114 (G)	CTR	0.56	0.90		%
	V <sub>CE</sub> = 5 V, I <sub>F</sub> = 5 mA	TCET1110 (G)	CTR	0.50		6.0	%
	V <sub>CE</sub> = 5 V, I <sub>F</sub> = 5 mA	TCET1115 (G)	CTR	0.5		1.5	%
	V <sub>CE</sub> = 5 V, I <sub>F</sub> = 5 mA	TCET1116 (G)	CTR	1.0		3.0	%
	V <sub>CE</sub> = 5 V, I <sub>F</sub> = 5 mA	TCET1117 (G)	CTR	0.8		1.6	%
	V <sub>CE</sub> = 5 V, I <sub>F</sub> = 5 mA	TCET1118 (G)	CTR	1.3		2.6	%
	V <sub>CE</sub> = 5 V, I <sub>F</sub> = 5 mA	TCET1119 (G)	CTR	2.0		4.0	%
	V <sub>CE</sub> = 5 V, I <sub>F</sub> = 10 mA	TCET1111 (G)	CTR	0.40		0.8	%
	V <sub>CE</sub> = 5 V, I <sub>F</sub> = 10 mA	TCET1112 (G)	CTR	0.63		1.25	%
	V <sub>CE</sub> = 5 V, I <sub>F</sub> = 10 mA	TCET1113 (G)	CTR	1.0		2.0	%
	V <sub>CE</sub> = 5 V, I <sub>F</sub> = 10 mA	TCET1114 (G)	CTR	1.6		3.2	%

### Maximum Safety Ratings

(according to VDE 0884) see figure 1

This optocoupler is suitable for safe electrical isolation only within the safety ratings.

Compliance with the safety ratings shall be ensured by means of suitable protective circuits.

### Emitter

Parameter	Symbol	Max	Unit
Forward current	$I_F$	130	mA

### Detector

Parameter	Symbol	Max	Unit
Power dissipation	$P_{Diss}$	265	mW

### Coupler

Parameter	Symbol	Max	Unit
Rated impulse voltage	$V_{IOTM}$	8	kV
Safety temperature	$T_{si}$	150	°C

### Insulation Rated Parameters

Parameter	Test condition	Symbol	Min	Unit
Partial discharge test voltage - Routine test	100 %, $t_{test} = 1$ s	$V_{pd}$	1.6	kV
Partial discharge test voltage - Lot test (sample test), (see figure 2)	$t_{Tr} = 60$ s, $t_{test} = 10$ s	$V_{IOTM}$	8	kV
	$t_{Tr} = 60$ s, $t_{test} = 10$ s	$V_{pd}$	1.3	kV
Insulation resistance	$V_{IO} = 500$ V	$R_{IO}$	$10^{12}$	$\Omega$
	$V_{IO} = 500$ V, $T_{amb} = 100$ °C	$R_{IO}$	$10^{11}$	$\Omega$
	$V_{IO} = 500$ V, $T_{amb} = 150$ °C (construction test only)	$R_{IO}$	$10^9$	$\Omega$

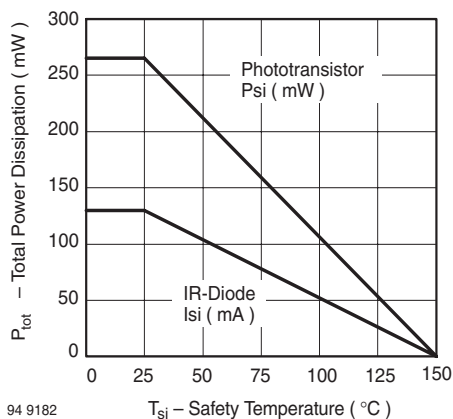

Figure 1. Derating diagram

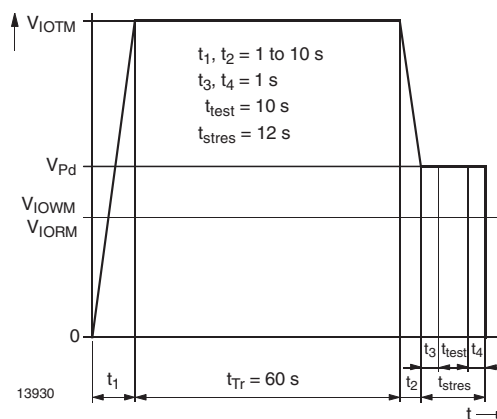

Figure 2. Test pulse diagram for sample test according to DIN VDE 0884; IEC60747

## Switching Characteristics

Parameter	Test condition	Symbol	Typ.	Unit
Delay time (see figure 3)	$V_S = 5\text{ V}$ , $I_C = 2\text{ mA}$ , $R_L = 100\ \Omega$	$t_d$	3.0	$\mu\text{s}$
Rise time (see figure 3)	$V_S = 5\text{ V}$ , $I_C = 2\text{ mA}$ , $R_L = 100\ \Omega$	$t_r$	3.0	$\mu\text{s}$
Turn-on time (see figure 3)	$V_S = 5\text{ V}$ , $I_C = 2\text{ mA}$ , $R_L = 100\ \Omega$	$t_{on}$	6.0	$\mu\text{s}$
Storage time (see figure 3)	$V_S = 5\text{ V}$ , $I_C = 2\text{ mA}$ , $R_L = 100\ \Omega$	$t_s$	0.3	$\mu\text{s}$
Fall time (see figure 3)	$V_S = 5\text{ V}$ , $I_C = 2\text{ mA}$ , $R_L = 100\ \Omega$	$t_f$	4.7	$\mu\text{s}$
Turn-off time (see figure 3)	$V_S = 5\text{ V}$ , $I_C = 2\text{ mA}$ , $R_L = 100\ \Omega$	$t_{off}$	5.0	$\mu\text{s}$
Turn-on time see figure 4)	$V_S = 5\text{ V}$ , $I_F = 10\text{ mA}$ , $R_L = 1\text{ k}\Omega$	$t_{on}$	9.0	$\mu\text{s}$
Turn-off time see figure 4)	$V_S = 5\text{ V}$ , $I_F = 10\text{ mA}$ , $R_L = 1\text{ k}\Omega$	$t_{off}$	10.0	$\mu\text{s}$

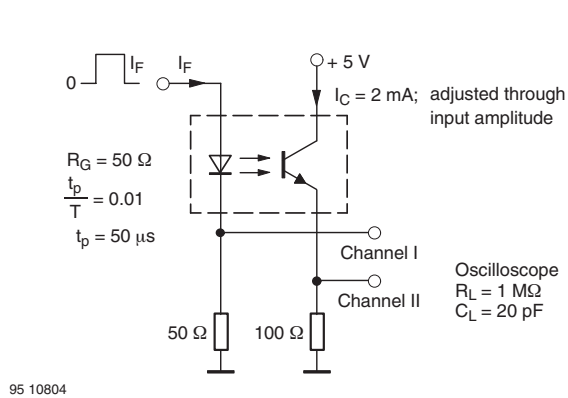

Figure 3. Test circuit, non-saturated operation

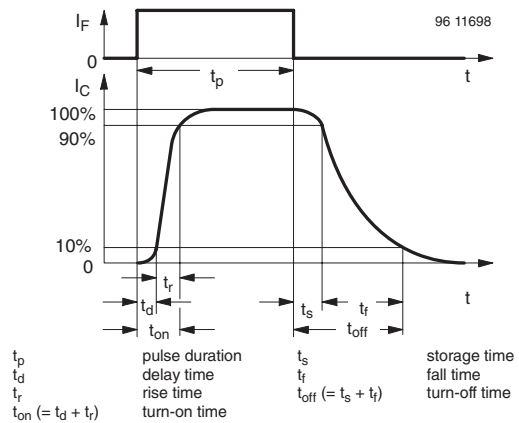

Figure 5. Switching times

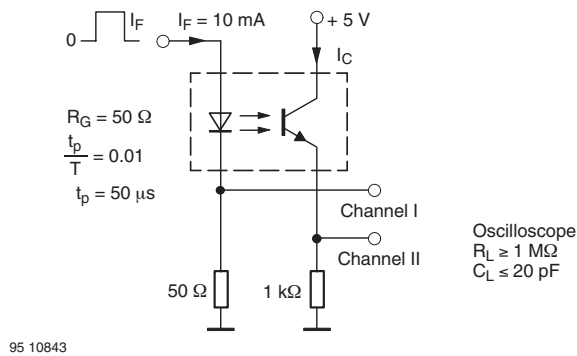

Figure 4. Test circuit, saturated operation

## Typical Characteristics ( $T_{amb} = 25\text{ }^{\circ}\text{C}$ unless otherwise specified)

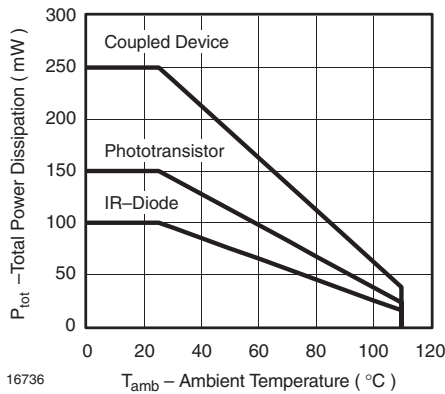

Figure 6. Total Power Dissipation vs. Ambient Temperature

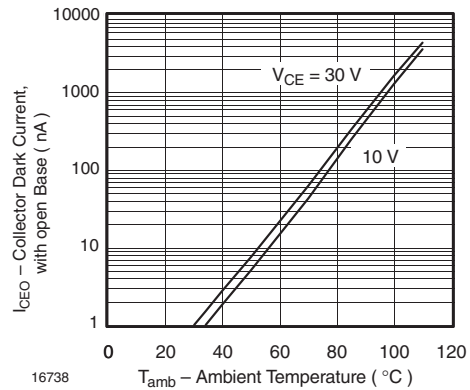

Figure 9. Collector Dark Current vs. Ambient Temperature

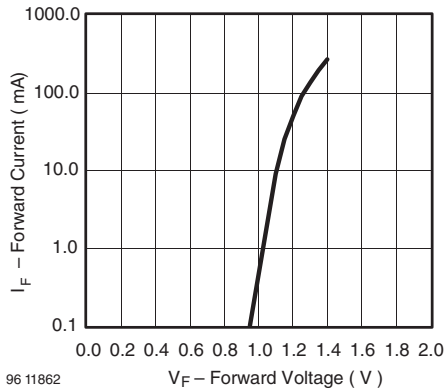

Figure 7. Forward Current vs. Forward Voltage

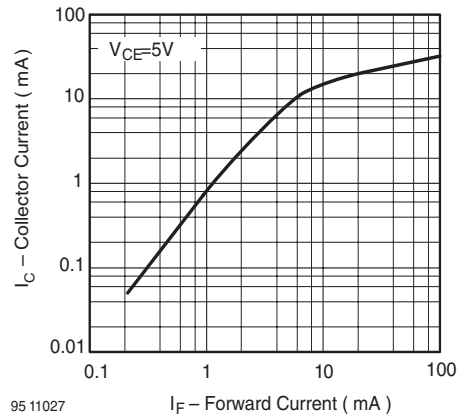

Figure 10. Collector Current vs. Forward Current

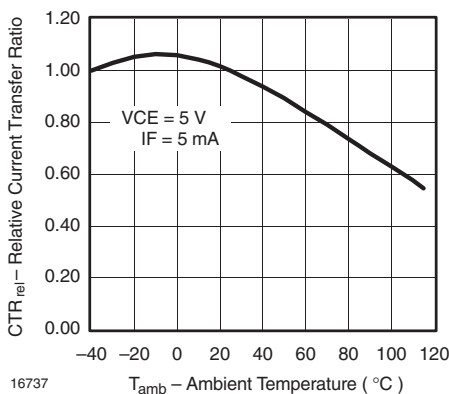

Figure 8. Relative Current Transfer Ratio vs. Ambient Temperature

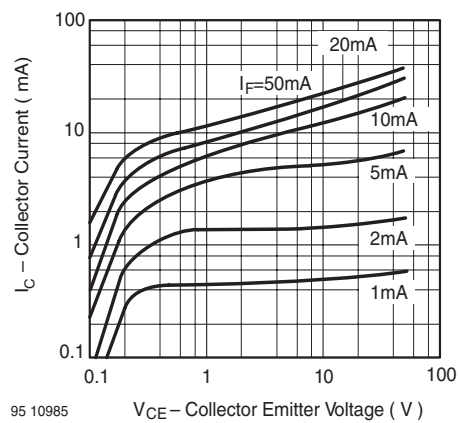
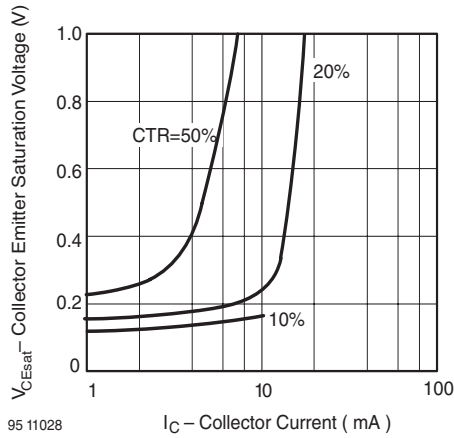
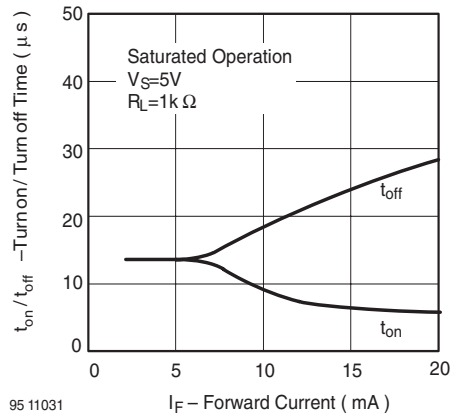

Figure 11. Collector Current vs. Collector Emitter Voltage



95 11028

Figure 12. Collector Emitter Saturation Voltage vs. Collector Current



95 11031

Figure 15. Turn on / off Time vs. Forward Current

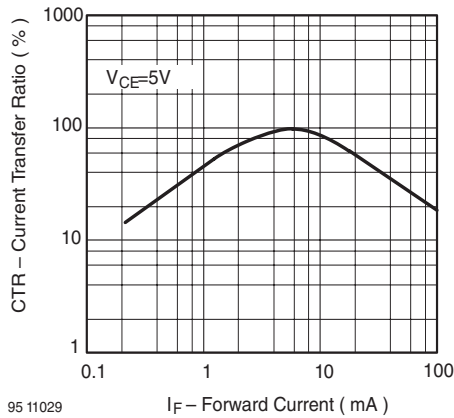

95 11029

Figure 13. Current Transfer Ratio vs. Forward Current

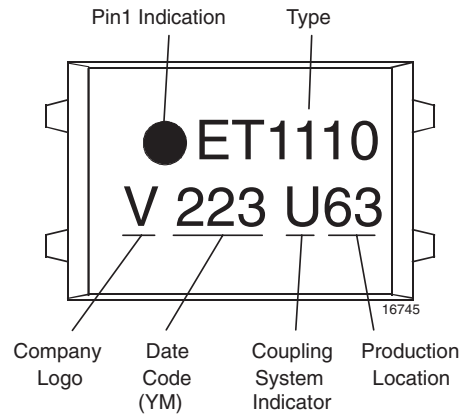
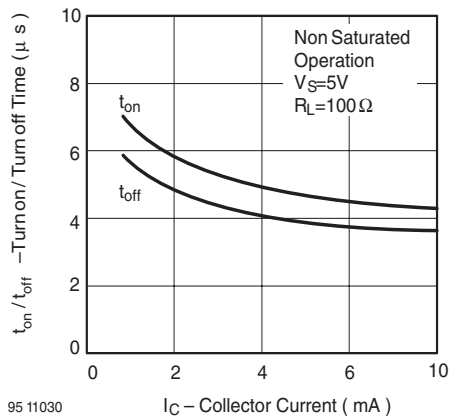

Figure 16. Marking example



95 11030

Figure 14. Turn on / off Time vs. Collector Current

# TCET111.(G)

Vishay Semiconductors



## Package Dimension of TCET111. in mm

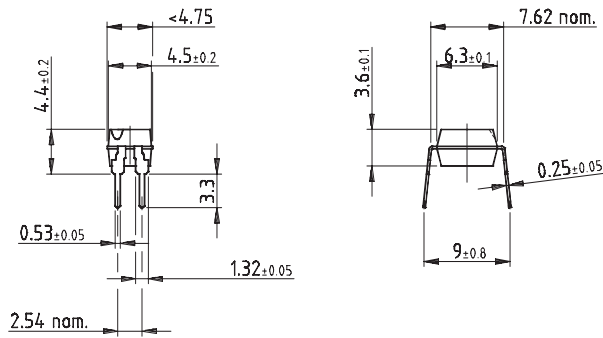

E.g.:  
special Features: endstackable  
to 2.54mm (.100") spacing

weight : ca 0.25g  
creepage distance : > 6mm  
air path : > 6mm  
after mounting on PC board

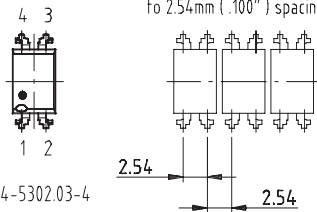

Drawing-No: 6.544-5302.03-4  
Issue: 5; 20.03.02



14789

## Package Dimension of TCLT11.G in mm

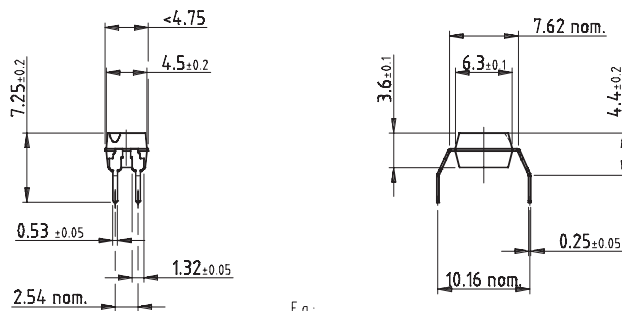

E.g.:  
special Features: endstackable  
to 2.54mm (.100") spacing

weight : ca 0.25g  
creepage distance : > 8mm  
air path : > 8mm  
after mounting on PC board

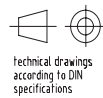
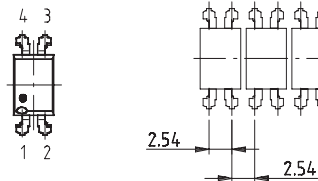

Drawing-No: 6.544-5303.03-4  
Issue: 4; 20.03.02

14792





## **Ozone Depleting Substances Policy Statement**

It is the policy of **Vishay Semiconductor GmbH** to

1. Meet all present and future national and international statutory requirements.
2. Regularly and continuously improve the performance of our products, processes, distribution and operating systems with respect to their impact on the health and safety of our employees and the public, as well as their impact on the environment.

It is particular concern to control or eliminate releases of those substances into the atmosphere which are known as ozone depleting substances (ODSs).

The Montreal Protocol (1987) and its London Amendments (1990) intend to severely restrict the use of ODSs and forbid their use within the next ten years. Various national and international initiatives are pressing for an earlier ban on these substances.

**Vishay Semiconductor GmbH** has been able to use its policy of continuous improvements to eliminate the use of ODSs listed in the following documents.

1. Annex A, B and list of transitional substances of the Montreal Protocol and the London Amendments respectively
2. Class I and II ozone depleting substances in the Clean Air Act Amendments of 1990 by the Environmental Protection Agency (EPA) in the USA
3. Council Decision 88/540/EEC and 91/690/EEC Annex A, B and C (transitional substances) respectively.

**Vishay Semiconductor GmbH** can certify that our semiconductors are not manufactured with ozone depleting substances and do not contain such substances.

**We reserve the right to make changes to improve technical design  
and may do so without further notice.**

Parameters can vary in different applications. All operating parameters must be validated for each customer application by the customer. Should the buyer use Vishay Semiconductors products for any unintended or unauthorized application, the buyer shall indemnify Vishay Semiconductors against all claims, costs, damages, and expenses, arising out of, directly or indirectly, any claim of personal damage, injury or death associated with such unintended or unauthorized use.

Vishay Semiconductor GmbH, P.O.B. 3535, D-74025 Heilbronn, Germany  
Telephone: 49 (0)7131 67 2831, Fax number: 49 (0)7131 67 2423