

1.0 Features

- For CMX612 Product Evaluation
- Adjunct Box or Feature Phone Configuration
- Single Power Supply Operation with on-board regulator
- LCD Display or RS232 Link to PC with Software
- Socketed Components for Adjustment
- User's Prototyping Area
- Socketed Space for Optional Telco-Specific Components
- Socketed PIC 16-Series μ C
- On-Board PIC Programming with Serial Interface and PC Software
- 2- to 4-Wire Interface with Handset Socket

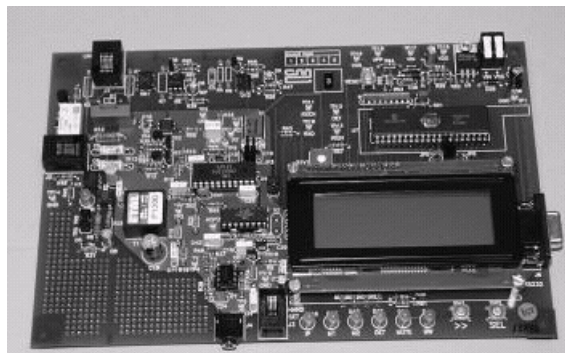

1.1 Brief Description

The EV6120 Evaluation Kit comprises a single board containing a CMX612, line interface components, PIC μ Controller and the option of using either the on-board 4-line LCD module or interfacing to a PC via a serial communications port. For the latter mode of operation Windows software is supplied. When using the LCD module two push-button switches are used to select the EV6120 functions.

The board is powered from a single 8 - 24V dc power supply; an on-board regulator sets V_{DD} . LEDs indicate control, and detect line status (IP, MODE1, MODE2, DET and MUTE) and the CMX612 may be driven from an external clock, or from its own crystal oscillator. Important signals can be monitored from test points. The CMX612 is socketed for easy replacement and a user prototyping area is provided.

On-board circuitry may be used to implement a wetting pulse and to place an ac or dc load on the line. An opto-mos relay connects the 2- to 4-wire interface/op-amp hybrid for voice communications to the line. An external phone socket for adjunct box demonstration is provided, the connection to which can be disabled with a relay. A mutable local voice input and DTMF generation (for CIDCW acknowledgement tone) are provided. Where components are telco-specific (line impedance, line protection, on-hook loads etc.) space is provided for the user to add appropriate components.

CONTENTS

<u>Section</u>	<u>Page</u>
1.0 Features	1
1.1 Brief Description	1
1.2 Preliminary Information.....	4
1.2.1 Laboratory Equipment.....	4
1.2.2 Handling Precautions	4
1.2.3 Telephone Line Connection	4
1.3 Quick Start	5
1.3.1 Setting-Up.....	5
1.3.2 Operation	5
1.4 Signal Lists	6
1.5 Circuit Schematics and Board Layouts	9
1.6 Detailed Description	12
1.6.1 Hardware Description - Evaluation Board	12
1.6.2 Software	14
1.6.3 Firmware	20
1.6.4 Additional Information.....	22
1.7 Performance Specification.....	26
1.7.1 Electrical Performance	26

Block Diagram

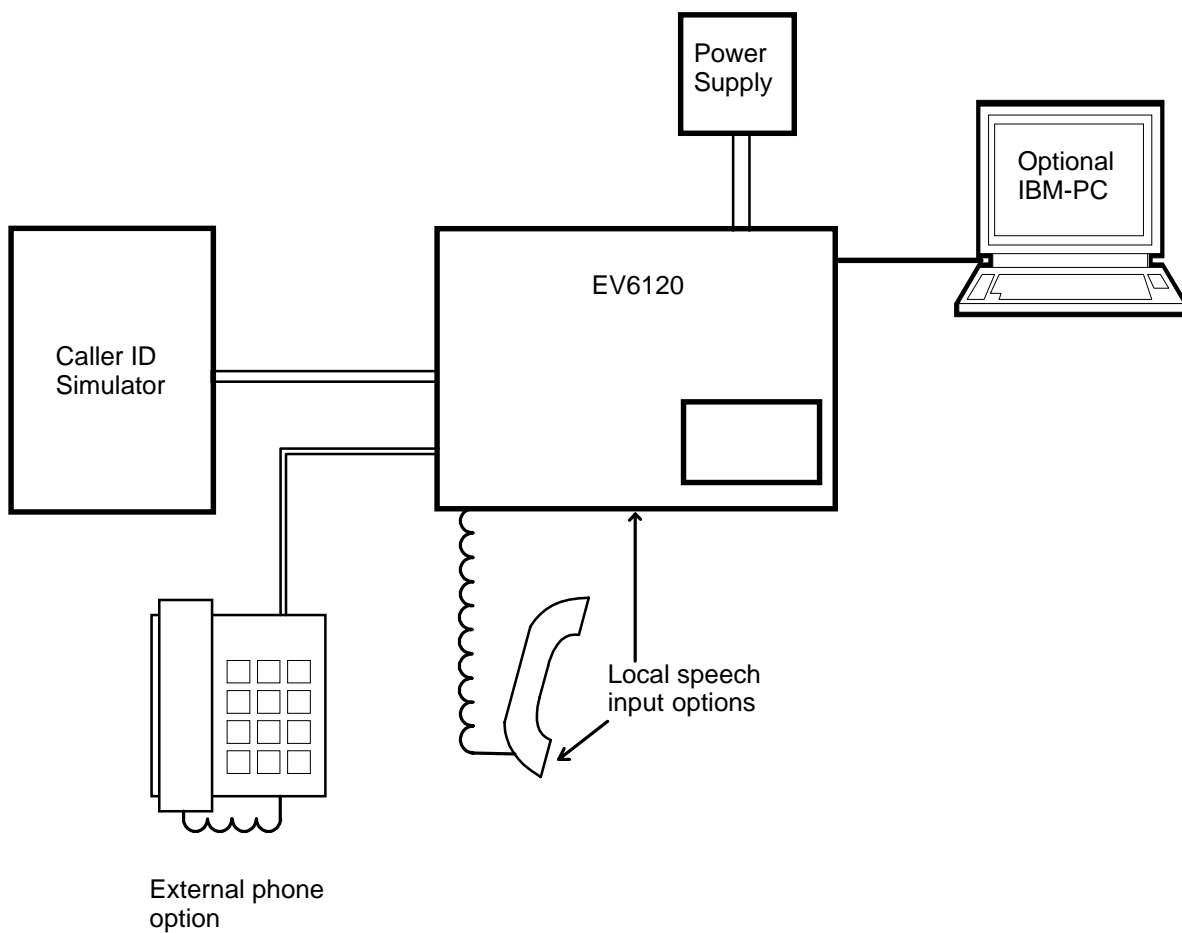

Figure 1 Block Diagram

1.2 Preliminary Information

1.2.1 Laboratory Equipment

The following laboratory equipment is needed to use this evaluation kit:

1.2.1.1 8 - 24V DC Power Supply.

1.2.1.2 Caller ID Simulator

1.2.1.3 Speech Source

If the user wishes to control the EV6120 from a PC and/or re-program a new PIC on the board.

1.2.1.4 An IBM compatible PC; 20MHz '386 or better, running Microsoft Windows™ 3.11 / '95 /NT. The re-programming software supplied (**PICPROGB.EXE**) runs most efficiently under DOS and cannot be used with Windows NT.

1.2.2 Handling Precautions

Like most evaluation kits, this product is designed for use in laboratory environments. The following practices will help ensure its proper operation.

1.2.2.1 Static Protection

This product uses low power CMOS circuits which may be damaged by electrostatic discharge. Partially damaged circuits may function erroneously, leading to misleading results. Observe ESD precautions at all times when handling this product.

1.2.2.2 Contents - Unpacking

Please ensure that you have received all of the items listed on the separate information sheet (EK6120) and notify CML within 7 working days if the delivery is incomplete.

1.2.3 Approvals

This Evaluation Kit is not approved for direct or indirect connection to any public telecommunication system. Users are advised to observe local statutory requirements which may apply to this product.

1.3 Quick Start

This section provides instructions for users who wish to experiment immediately with the evaluation kit. A fuller description of the kit and its use linked to a PC appears later in this document.

1.3.1 Setting-Up

THE EV6120 COMES PRE-CONFIGURED FOR OPERATION AT 3.3 VOLTS.

An RJ11 (US style) phone jack is provided for caller ID simulator connection. Power is connected via the two-way socket, J5. No board adjustments are required by the user. Telco-specific components may be added, as required.

1.3.2 Operation

Ensure no connection to serial port connector J6 and switch on the power supply. The message EF6120Vx.x will be visible on the LCD module plus an indication as to which function option is selected. The two push button switches, SW1 and SW2 are used to scroll through and select from the menu displayed on the bottom row of the LCD module.

A fuller description of these functions is given later in the document.

Off-hook line matching is provided by R16, R19 and C11. The default components are for a 600Ω line.

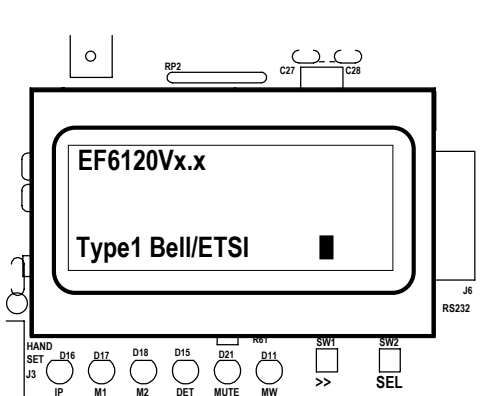

Figure 2 Function Selection

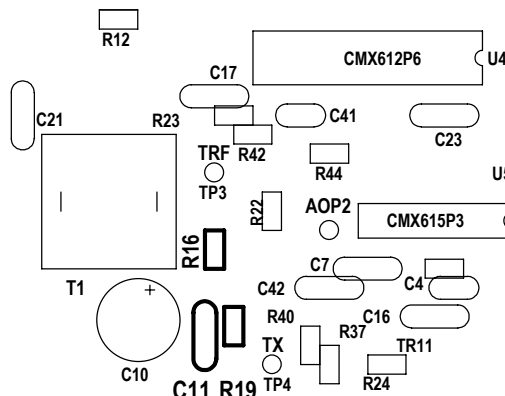

Figure 3 Matching Network

The dc load is provided by a gyrator circuit. The dc mask characteristic may be altered by changing the value of R28.

1.4 Signal Lists

CONNECTOR PINOUT - EVALUATION BOARD				
Connector Ref.	Connector Pin No.	Signal Name	Signal Type	Description
J1	1, 2	-	-	Not Used. No connection needed.
	3	A	BI	Bidirectional 'phone line (A = TIP).
	4	B	BI	Bidirectional 'phone line (B = RING).
	5, 6	-	-	Not Used. No connection needed.
J2	1, 2	-	-	Not Used. No connection needed.
	3	B	BI	Bidirectional external 'phone socket (B = RING).
	4	A	BI	Bidirectional external 'phone socket (A = TIP).
	5, 6	-	-	Not Used. No connection needed.
J3	1		Input	Microphone +ve.
	2		Output	Speaker drive.
	3		Output	Speaker drive.
	4		Input	Microphone -ve.
J4	1 tip/pin2	VSS speech	Power Input) Jack socket for mutable input) from external speech source.
J5	1	V _{IN}	Power	+ve power from external power supply.
	2	V _{SS}	Power	0V power from external power supply.
J6	1	DCD	Output	PC connection (linked to DTR).
	2	RXD	Output	PC data input.
	3	TXD	Input	PC data output.
	4	DTR	Input	PC connection.
	5	V _{SS}	Power	0V common connection to PC.
	6	DSR	Output	PC connection (linked to DTR).
	7	RTS	Input	PC 'RTS' connection.
	8	CTS	Output	PC 'CTS' connection.
	9	-	-	-

TEST POINTS - EVALUATION BOARD		
Test Point Ref.	Default Measurement	Description
TP1	0V	VSS connection.
TP2	0V	VSS connection.
TP3	-	Ev board side of transformer.
TP4	-	Hybrid transmit input (Local Voice and Ack).
TP5	-	Hybrid receive output/CMX612 AOP2 (Remote Voice/CAS/FSK).
TP6	-	Muteable local speech input.
TP7	-	CMX612 RD input, pin 3.
TP8	-	CMX612 RT signal, pin 4.
TP9	-	CMX612 AOP1 signal, pin 5.
TP10	-	CMX612 RXD output, pin 21.
TP11	-	CMX612 RXCK input, pin 19.
TP12	-	CMX612 DET output, pin 18.
TP13	-	CMX612 IRQN output, pin 17. A pull-up resistor R43 is included on board.
TP14	0V	VSS connection.
TP15	0V	VSS connection.
TP16	V _{DD}	VPP programming voltage input for PIC16C74A.
TP17	8 - 24V	V _{IN} connection.
TP18	3.3V	V _{DD} connection.
TP19	0V	CAS/SDT/VMWI detect indicator - labelled CAS.

JUMPERS - EVALUATION BOARD			
Link Ref.	Positions	Default Position	Description
JP2	1-2	s/c	Disconnect to supply an external clock to CMX612 via pin 2.
JP3	1-2	s/c	Disconnect when supplying external clock to CMX612 via JP2 pin 2.
JP4	1-2	s/c	Disconnect to measure I _{DD} of evaluation device.
JP5	1-2	s/c	Disconnect to supply an external clock to PIC16C74A via pin 1.
JP6	1-2	s/c	Disconnect when supplying external clock to PIC16C74A via JP5 pin 1.

s/c = short circuit

SWITCHES - EVALUATION BOARD			
Link Ref.	Positions	Default Position	Description
SW1	open/closed	open	LCD menu item scroll button.
SW2	open/closed	open	LCD menu item select button.
SW3	open/closed	open	PIC16C74A reset.

1.5 Circuit Schematics and Board Layouts

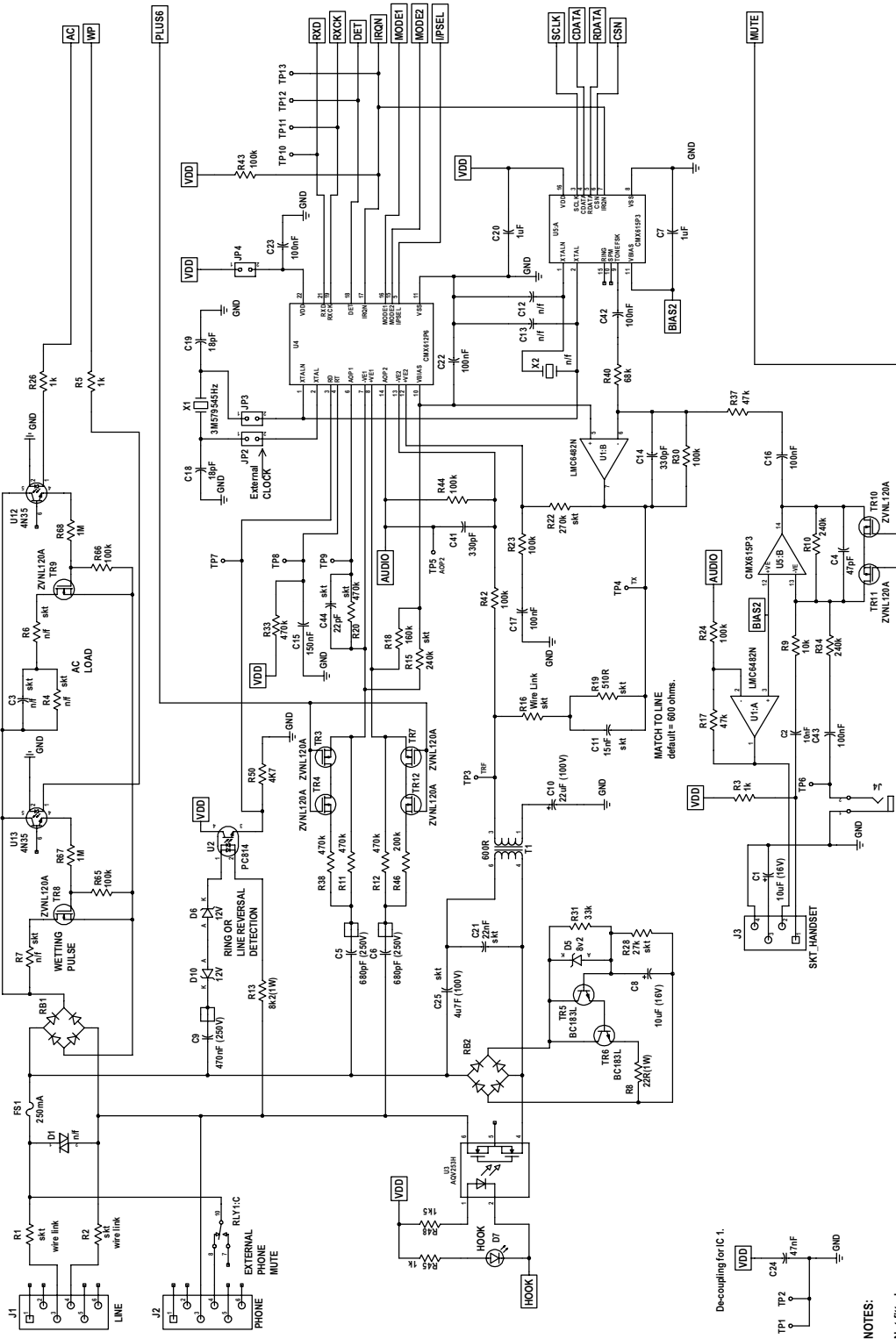

Figure 4 Analogue Section

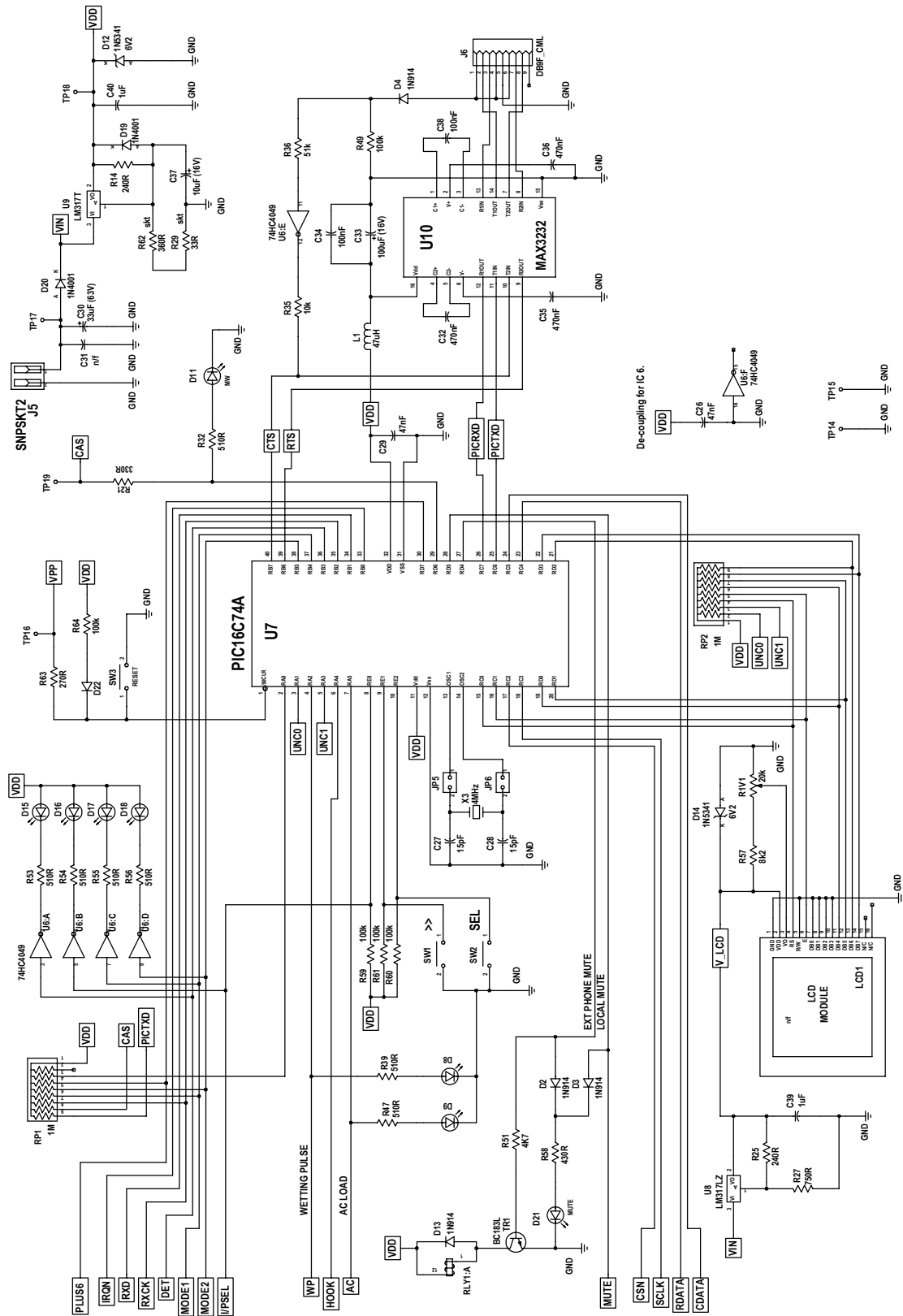

Figure 5 Control Section

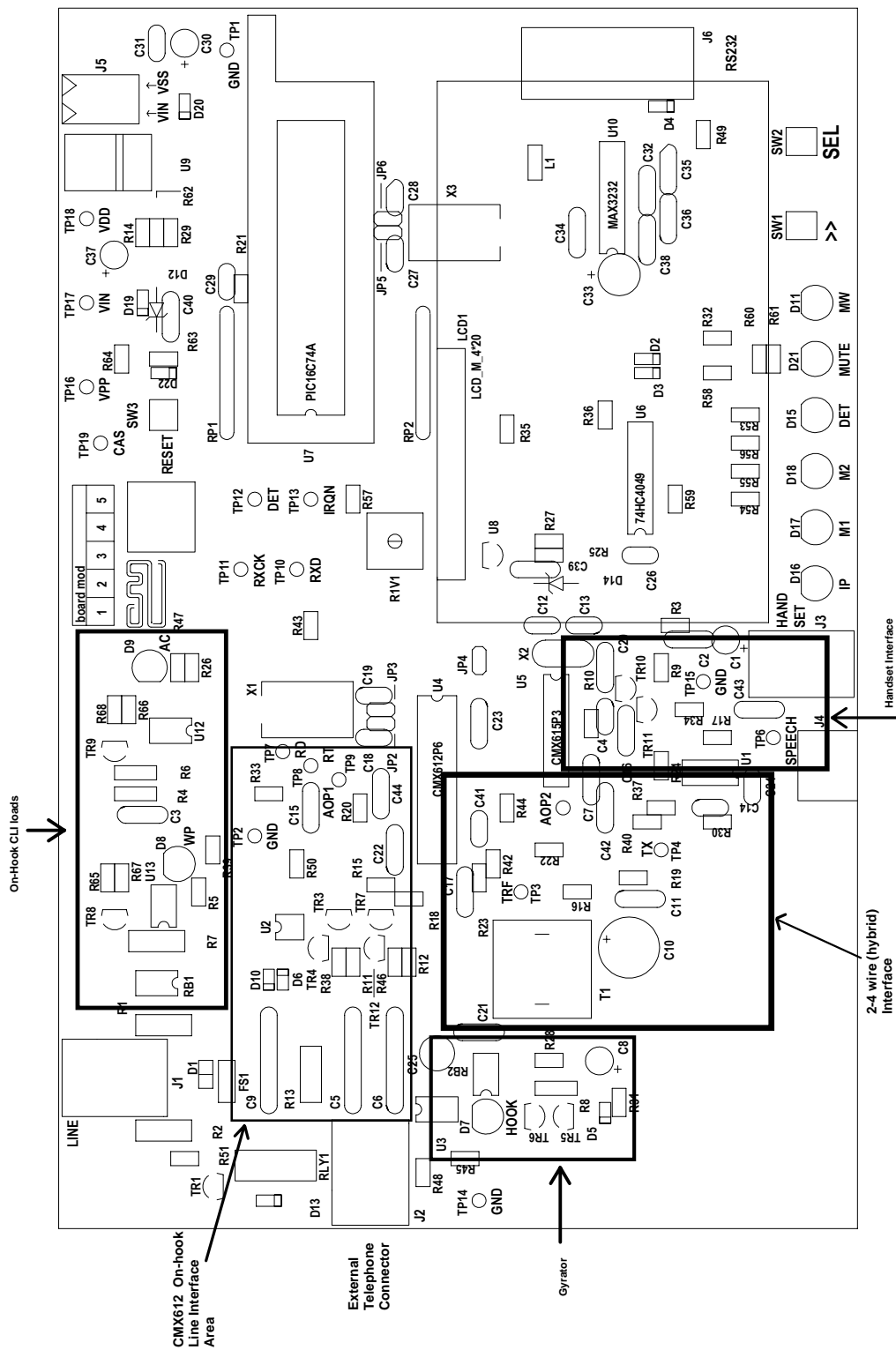

Figure 6 Evaluation Board Layout

1.6 Detailed Description

1.6.1 Hardware Description - Evaluation Board

1.6.1.1 Line Interfacing.

The EV6120 is designed to work with a range of CLI simulators whilst connected to a PC and other laboratory equipment. This has led to an opto-isolated line interface more akin to a modem than commercial feature phones which are not designed to work with other equipment and are generally not fully isolated from the line.

- Line protection is provided by R1 (47 Ω), R2 (47 Ω), and D1 (Philips BR211 series 140V). These components are not fitted, but suitable values for UK applications are suggested in brackets. Wire links which bypass R1 and R2 will need to be removed if these resistors are fitted.
- Ring and line reversal detection is provided by an opto-isolated circuit formed by components C9, D6, D10, R13, R50 and U2. Timing components R33 and C15 ensure a constant detect output for a ring burst. See CMX612 data sheet for further details.
- The transformer and op-amp hybrid (formed by U1:B and CMX612:AOP2) is connected to the phone line by an optoMOS relay, U3. When 'off-hook' an adjacent LED is illuminated.

Line impedance matching is required in order to place signals on the line (acknowledgement tone of type 2 / cidcw sequences) and to be able to send and receive speech and other signals (feature phone mode).

These are suggested component values for various reference impedances using the EV6120 circuitry. Note that R22 adjusts the level of tx rejection on the rx side of the hybrid.

ref Z	C25	C21	R16	C11	R19	R22
600 Ω (default)	4 μ 7F	22nF	0 Ω	15nF	510 Ω	270k Ω
900 Ω	4 μ 7F	1nF	0 Ω	4n7F	750 Ω	330k Ω
CTR21(complex)	3 μ 3F	56nF	240 Ω	150nF	750 Ω	390k Ω

- A gyrator circuit draws dc loop current in the off-hook state. The current drawn may be altered by adjusting the value of R28. This is designed to function with a dc current limited line.
- Off-hook loads, specified for type1 CLI, can be applied by fitting the TELCO specific components not fitted by CML.

An ac or dc load is provided by R4 (827 Ω), R6 (1386 Ω) and C3 (139nF). These components are not fitted, but suitable values for UK applications are suggested in brackets. This load is switched in by U12 and TR9. An LED is illuminated when this occurs.

A wetting pulse is provided by R7, which is not fitted. For UK applications, a suitable value may be in the region of 240 Ω to 350 Ω . The wetting pulse is switched in by U13 and TR8. An LED is illuminated when this occurs.

1.6.1.2 CMX612 Detector Signal Paths.

There are two input signal path options with the CMX612, AOP1 and AOP2. AOP1 is connected directly across the line and AOP2 forms the rx side of the 2- to 4-wire interface.

The LED marked 'IP' indicates the state of the CMX612 input select pin.

Note that if the signal path chosen is via the 2- to 4-wire interface absolute levels at the CMX612 will depend upon the line impedance of the caller ID simulator in use and on the quality of the termination of that line. This will have a bearing on decode and not-decode levels.

1.6.1.3 External Phone

A second RJ11 socket, J2, is provided for an external telephone when the EV6120 is demonstrating adjunct box functions. The relay, RLY1, which is normally closed will mute the external telephone. When muted/disabled the LED marked 'MUTE' is illuminated.

1.6.1.4 Speech Paths

When emulating a feature phone, a mutable local speech path is available. A speech signal may be input at either testpoint TP6, jack socket J4, or from a telephone handset (not provided) connected to socket J3. When muted the LED marked 'MUTE' is illuminated.

Note that the local speech path (input at TP6 or J4) has a gain of ≈ 6 dB.

Far end signals are routed from the rx output of the hybrid (CMX612: AOP2), via op-amp U1:A, to the handset connector socket, J3.

1.6.1.5 DTMF Acknowledgement Code

The DTMF acknowledgement (digit D) for the type2 / off-hook / cidcw demonstrations is generated by U5 (CMX615) and fed to the Tx input of the 2- to 4-wire interface.

1.6.1.6 Operating Voltage

The operating voltage (V_{DD}) is set to 3.3Volts. This may be altered by changing components R62 and R29 which are socketed. To select 5.0Volts set R62 = 620 Ω and R29 = 100 Ω . The formula for calculating the values of R68 and R69 is as follows:-

$$R62 + R29 = \frac{240 (V_{DD} - 1.25)}{1.25}$$

Where 240 is the value of R14 in ohms and V_{DD} is the required supply voltage.

1.6.1.7 Clocks and Oscillators

- The CMX612 may use either an external clock or its own xtal oscillator. A 3.58MHz xtal is provided on-board for the latter method. Two jumpers JP2 and JP3, which are normally fitted, select the xtal oscillator. An external clock may be supplied to JP2 pin 2 once the jumpers have been removed.
- The PIC16C74A may be provided with an external clock in the same way by removing jumpers JP5 and JP6. Note that PICs programmed by CML are only configured for use with the on-board 4MHz crystal.
- The DTMF generator (CMX615) uses the clock from the CMX612. This device cannot be enabled when the CMX612 is in zero power mode.

1.6.2 Software

This section describes the operation of the EV6120 kit via the RS232 lead and the Windows software supplied. The sequence of events for the demonstrations is covered in the Section 1.6.3 (Firmware).

1.6.2.1 Installation

The ES6120 Windows Application Software consists of a single executable file named ES6120xx.EXE, where xx refers to the version number. Copy this from its 3.5" floppy disk to the hard disk of the user's PC.

Windows NT and '95

For convenient and quick launching of the program create an ES6120 shortcut within the Start menu or Desktop.

Windows 3.11

For convenient and quick launching of the ES6120 software create a new program group and ES6120 icon.

1.6.2.2 Start-up

When the application is run, the initialise dialog box will pop-up in front of the applications main window.

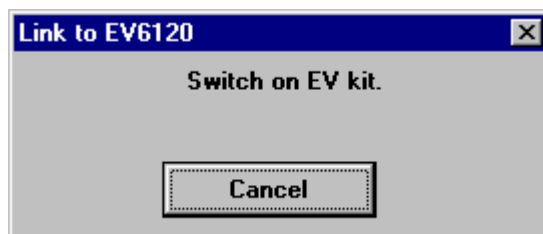

At this point ensure the EV6120 is connected to an RS232 serial port of the PC, via connector J6, and turn on the power to the board. If cancel is selected the PC will not make a connection to the EV6120 board.

1.6.2.3 Main Window

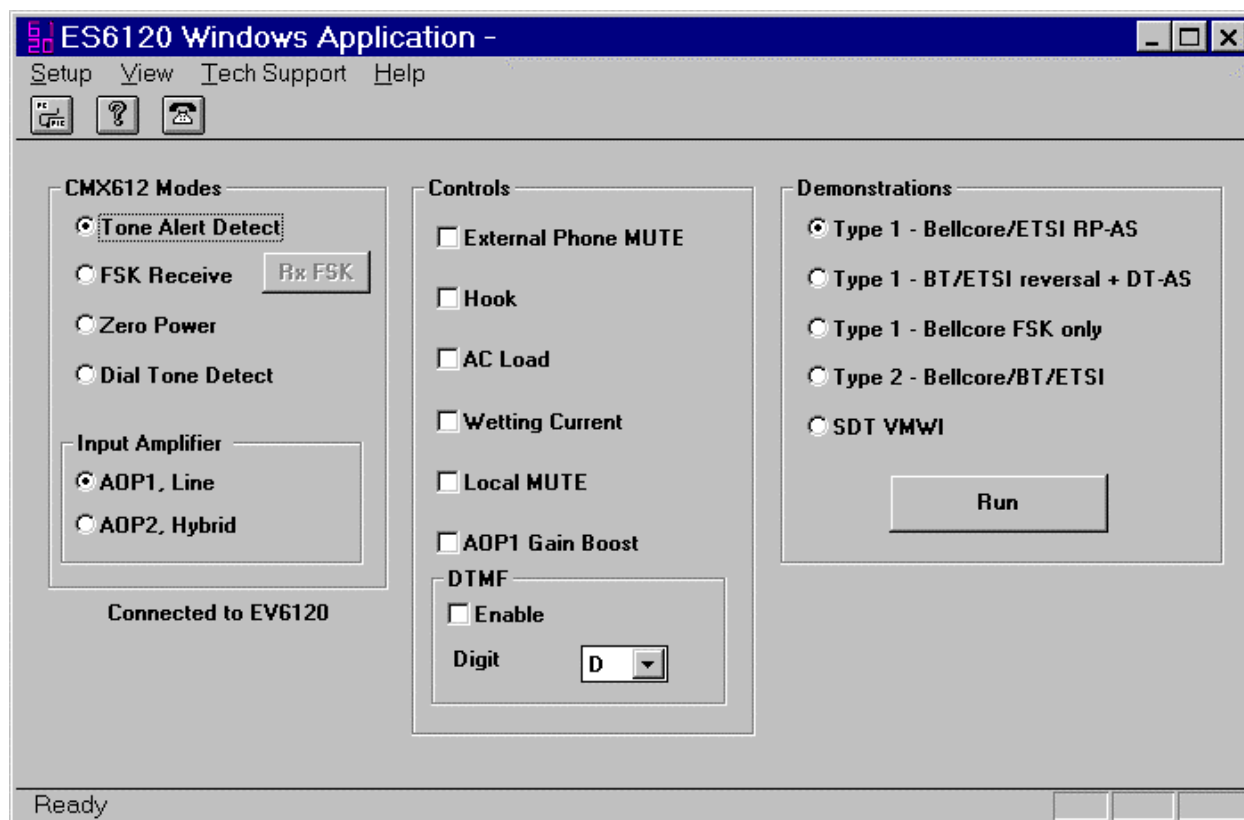

- 'CMX612 Modes'. Selects CMX612 operating mode and detector signal source.
- 'EV6120 Controls'. Basic control of EV6120 circuits.
- 'EV6120 Demonstrations'. Select a demonstration and press run.

1.6.2.4 RxFSK dialog box

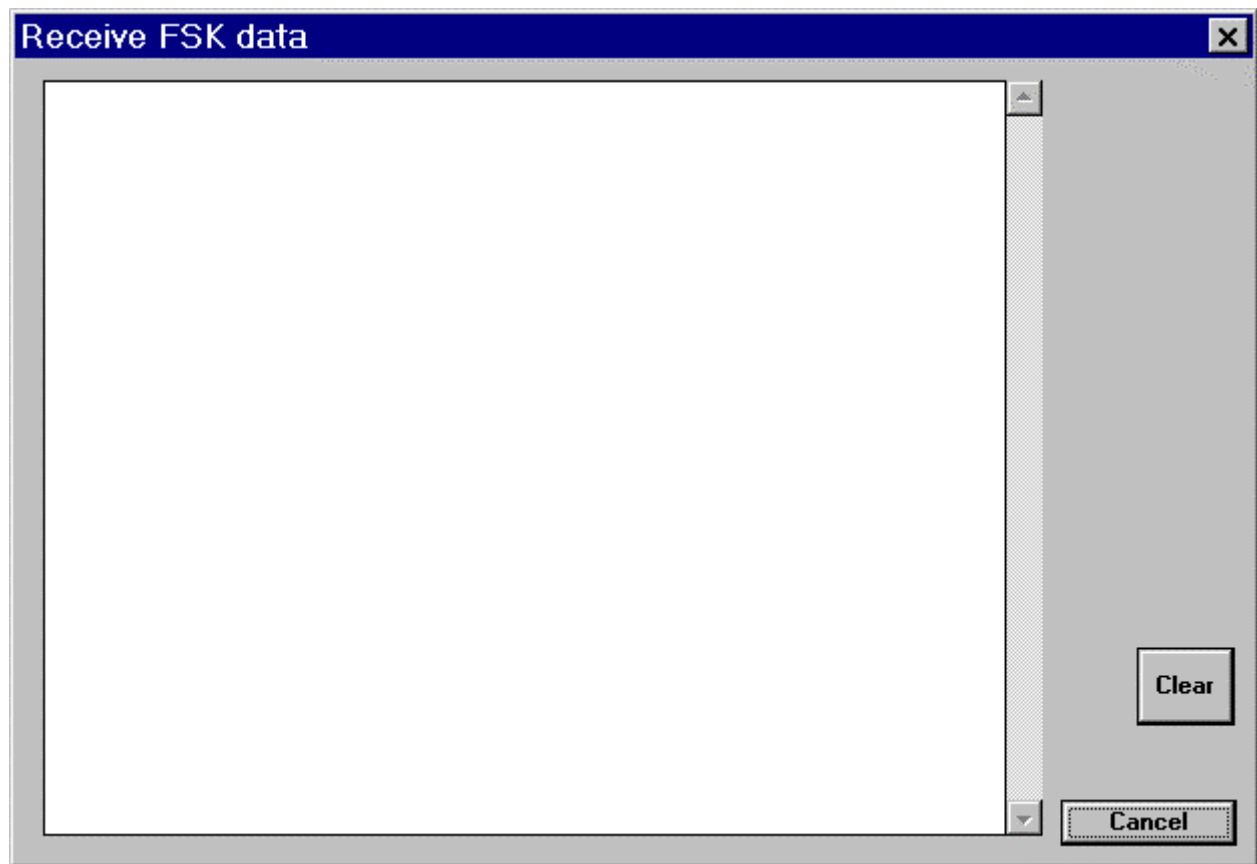

- The EV6120 board is instructed to operate the CMX612 in receive mode with data re-timing selected.
- Characters received by the CMX612 will be displayed in the main read-only edit box. The display is limited to 20,000 characters and will be cleared when this limit is exceeded.

1.6.2.5 Type 1/on-hook demonstration dialog box

This dialog pops up when any of the type 1 CLI demonstrations is selected. The precise selection is displayed in the top left of the panel, in this case the BT demonstration is selected. Use these demonstrations for FSK type VMWI.

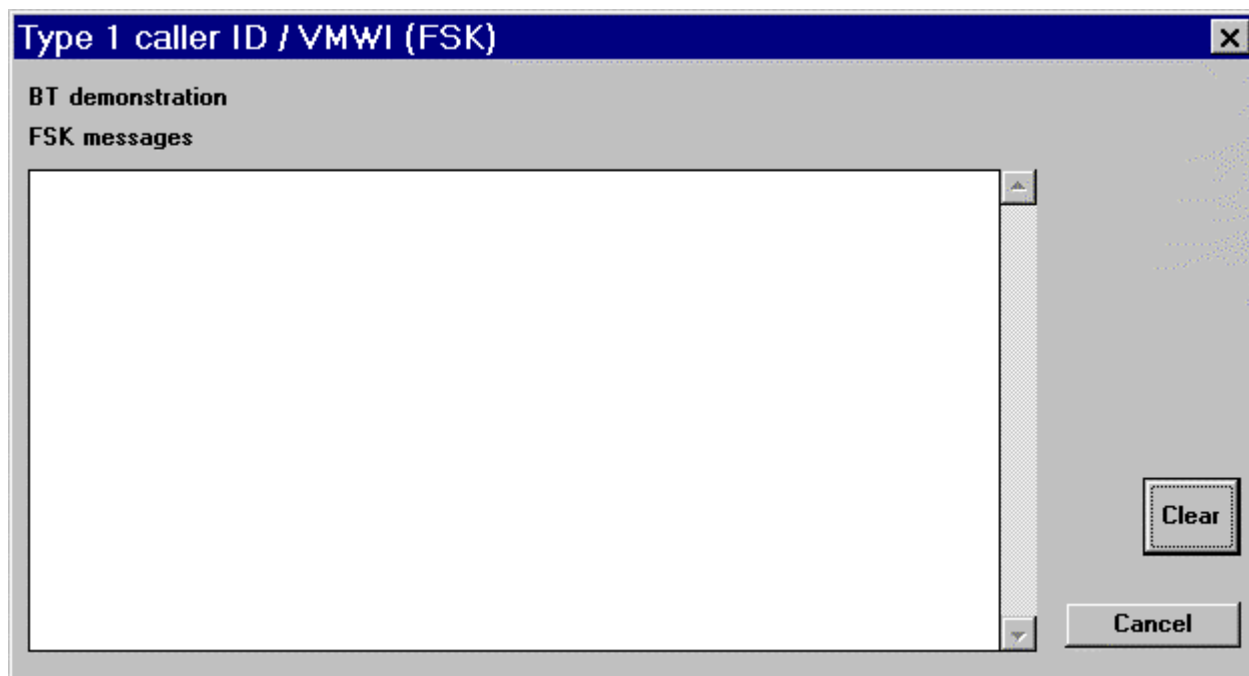

- The EV6120 is instructed to run the appropriate caller ID demonstration. The message data is sent back to the PC and displayed in the main read-only edit box.
- The display is as described for the RxFSK dialog box.

1.6.2.6 Type 2/off-hook demonstration dialog box

Ensure that a valid DTMF digit, for the CIDCW acknowledgement tone, is set from the main panel before running this demonstration

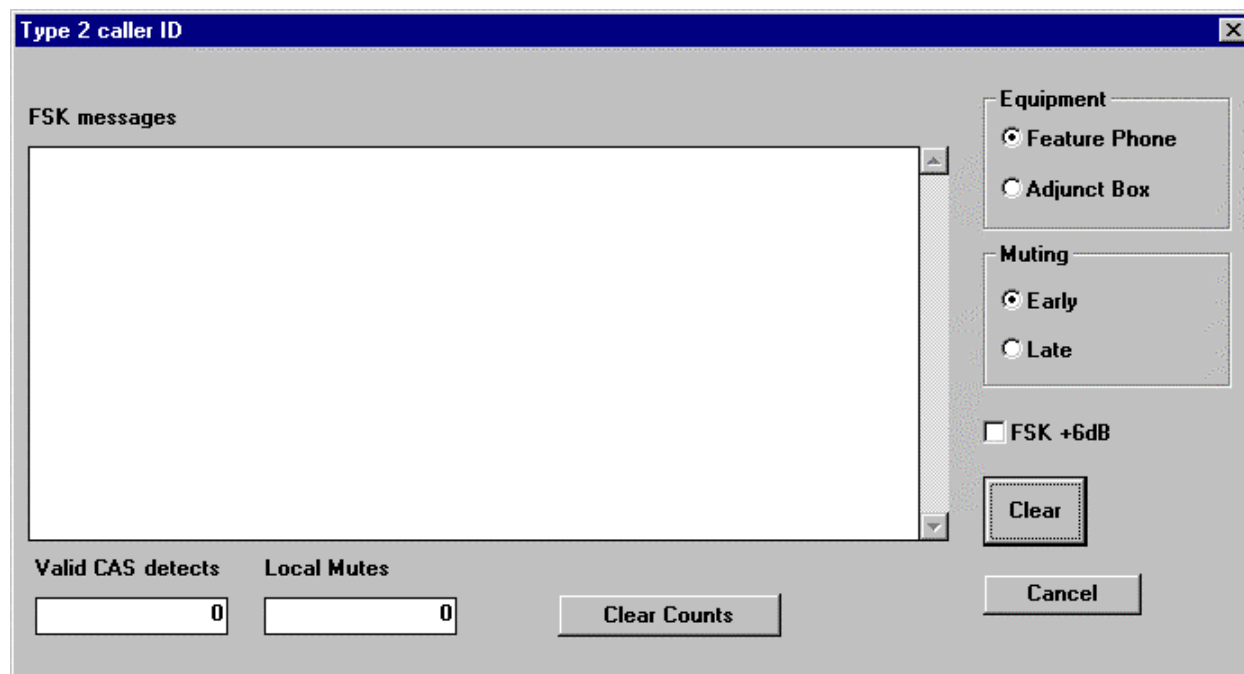

- The EV6120 is instructed to perform the off-hook / type 2 / CIDCW demonstration. The nature of the demonstration can be altered by selecting Feature Phone or Adjunct Box and Early or Late muting on the right hand side of the dialog box.
- If FSK +6dB is checked the gain in the input path formed around AOP1 of the CMX612 is increased by 6dB for the FSK receive part of type 2 CLI. For the feature phone case this will also switch the input path from AOP2 to AOP1 of the CMX612 during the FSK receive.
- The valid CAS detects and local Mute counters are provided to assist with talk-off and talk-down testing, see later sections.
- CLI message data is shown as described for the type 1 dialog box.

1.6.2.7 (Stuttered) Dial Tone detect Algorithm Demonstration, - US cadence.

Refer to separate applications note for details of this algorithm.

- This demonstration uses the EV6120's own hook circuitry to put the line into an off-hook state. The dial tone, stuttered or otherwise, is monitored straight across the line, via CMX612 AOP1. This emulates the worst case scenario for dial tone detect when another extension goes off-hook and the unit under test must monitor signals straight across the line.
- Algorithm constants may be altered by the user. New values are downloaded to the EV6120 whenever the 'Start' button is clicked.
- The length of each test is 2.1 seconds. In continuous mode there is an idle period of 1 second between each test.

1.6.3 Firmware

This section describes the operation of the EV6120 kit using the LCD module and the demonstration selection switches SW1 and SW2. It also describes the sequence of events followed by the available demonstrations.

1.6.3.1 Start-up

As described in Quick start section.

The opening messages will be EF6120 Vx.x (where x.x represents the version number), plus a menu from which demonstrations may be selected using SW1 (>>) and SW2 (SElect).

SW1 (>>) will scroll along the menu items and SW2 (SElect) will select the currently highlighted menu item. When the cursor is above SW1 (>>) the EV6120 is idle. When the cursor is above SW2 (SElect) the currently displayed demonstration is active. Use SW2 (SElect) to exit the active demonstration.

When a new selection has been made the start up messages will be displayed on the LCD until a new CLI message has been received.

Note that the type2 CIDCW option has a sub-menu for feature phone or adjunct box mode.

1.6.3.2 BT type 1 demonstration

This demonstration covers the BT on-hook service initiated by a line reversal followed by an alert tone, see flowchart in CMX612 datasheet (application notes section). CLI message parameters are displayed on the LCD.

On the EV6120 board, FET TR8 is switched on to provide wetting current for 15ms during the silent period between the alert tone and the FSK data. A resistor can be fitted in the R7 position if a current wetting pulse is required.

FET TR9 is switched on during the FSK receive period. If an ac termination is required, components can be fitted in positions R4, R6 and C3.

1.6.3.3 Bellcore type 1 demonstration

This demonstration covers the Bellcore and ETSI on-hook services associated with ringing, see flowchart in CMX612 datasheet (application notes section). Any ringing of duration < 500ms is assumed to be a line reversal and is ignored. CLI message parameters are displayed on the LCD.

FET TR9 is energised during the FSK receive period. If an ac termination is required, components can be fitted in positions R4, R6 and C3.

1.6.3.4 FSK only type1 demonstration.

This demonstration covers the Bellcore on-hook service not associated with ringing. The CMX612 remains in rx mode continuously monitoring for FSK signals. Parameters are displayed as with other modes.

1.6.3.5 BT, ETSI and Bellcore type 2 demonstration

See flowchart in CMX612 datasheet (application notes section) for more information.

In 'Feature Phone' mode, the local speech path is enabled and muted when a CAS tone is detected (when the CMX612 DET output is set in tone alert mode, termed early mute). Also signals from the line, e.g. CAS tone, will be taken from the Rx side of the 2 to 4 wire interface.

In 'Adjunct Box' mode, the link to an external telephone, socket J2, is muted when a valid CAS tone has been received (when CMX612 IRQN pin goes low in tone alert mode, termed late mute).

If the EV6120 is linked to a PC, see section 1.6.2, the point at which muting occurs can be toggled between early and late.

Counters record the number of times muting has occurred (M) and the number of times a valid CAS tone has been detected (C). The counts are displayed on row 3 of the LCD.

DTMF digit 'D' is transmitted on to the phone line as an acknowledgement tone. If the EV6120 is linked to a PC other DTMF digits can be sent as an acknowledgement. CLI message parameters are displayed on the top two rows of the LCD.

Whilst the acknowledgement is being transmitted testpoint TP19, labelled CAS, will be HI. This 60mS pulse can be fed back to a CLI simulator for CAS performance testing.

1.6.3.6 (Stuttered) Dial Tone detect Algorithm Demonstration.

This is a simplified demonstration of the algorithm running in continuous mode only. The constants are fixed to default values and only the resulting dial or stuttered dial tone detect figures are shown. When the 'SEL' button is pressed the demonstration will halt at the end of the current test cycle.

During the idle period between tests the LED marked 'MW' will indicate the result of the last test. i.e. if a stuttered dial tone was detected the LED will be on and if a normal dial tone was detected the LED will be off.

1.6.4 Additional Information

1.6.4.1 Test configurations for EV6120

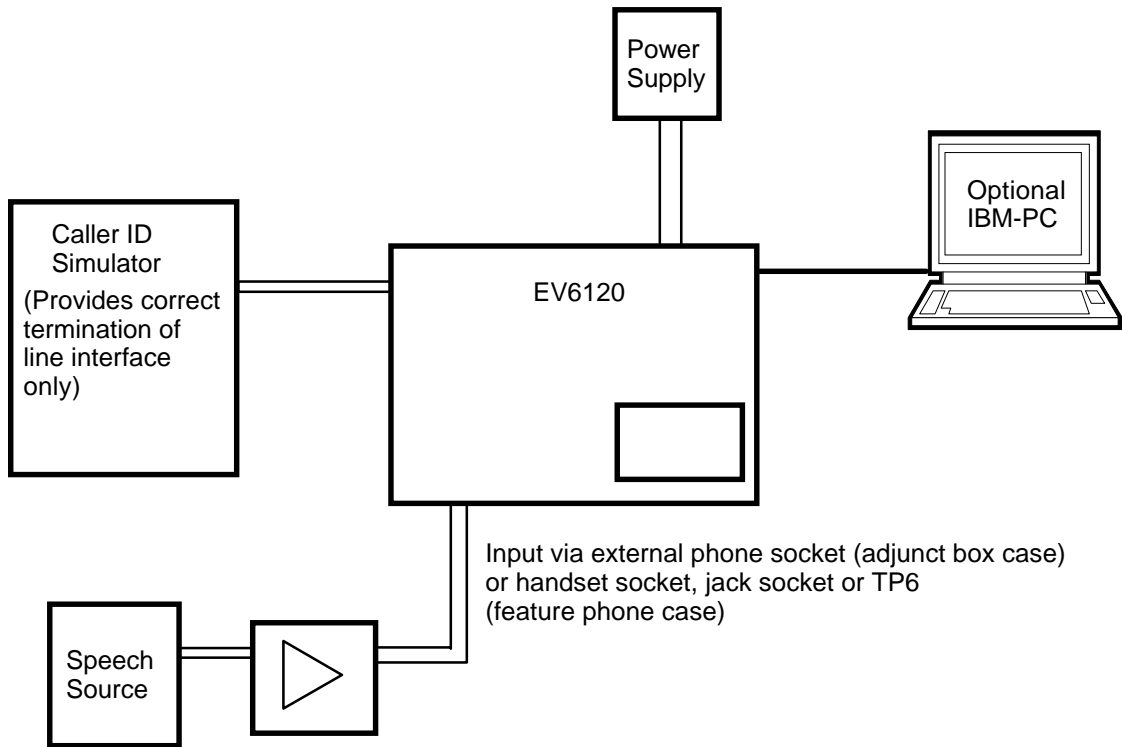

Figure 7 Near End Talk-Off Tests With The EV6120

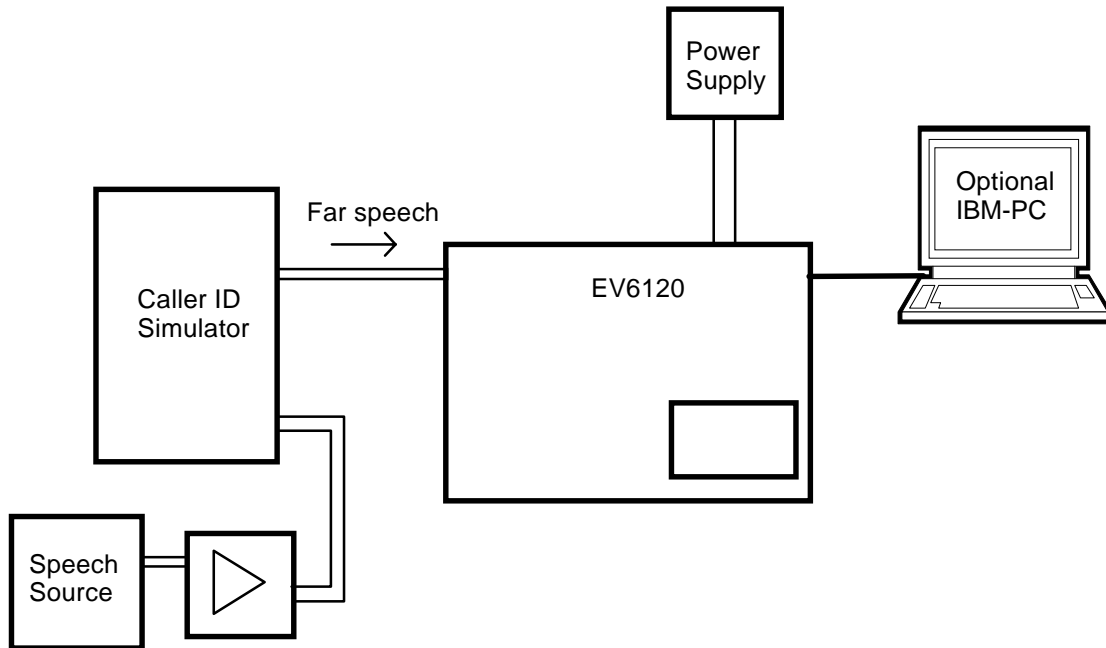

Figure 8 Far End Talk-Off Tests With The EV6120

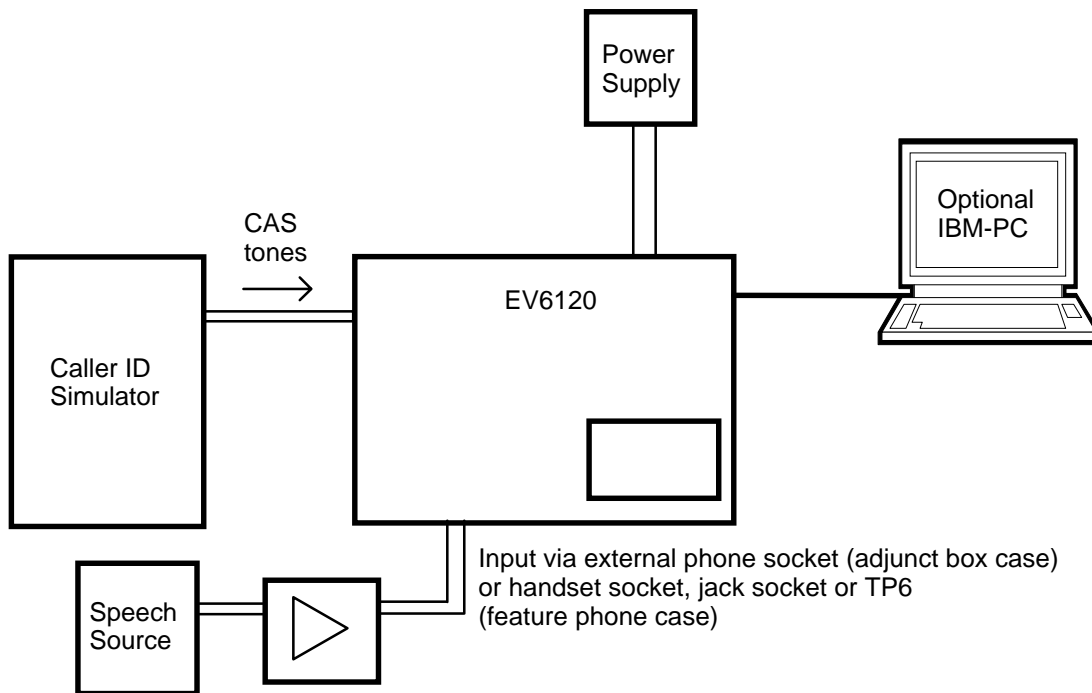

Figure 9 Talk Down Tests With The EV6120

1.6.4.2 In-circuit re-programming of PIC16C74A

In order that the PIC16C74A μ Controller may be re-programmed the existing program must be erased by placing the device in a uv- eraser for approximately 15 minutes. For boards fitted with an OTP device the user will need a fresh μ controller.

Note that V_{DD} must be set to 5.0 Volts for programming.

TO ENTER PROGRAMMING MODE

- (a) Ensure the windows application ES6120 is not running.
- (b) Connect the programming voltage ($V_{PP} = 12.5V$ to $13.5V$) power supply between test point TP16 (+ve) and V_{SS} (-ve).
- (c) Ensure the PIC μ C programming utility **PICPROGB.EXE** is loaded into the PC under DOS and the PC is connected to the evaluation kit.
- (d) Reset the EV6120 board by momentarily pressing switch, SW5

USING THE SOFTWARE - PICPROGB

This is supplied on disk as a self-documented executable file **PICPROGB.EXE** for a PC running DOS (either directly or as a DOS window in Windows 3.11 or '95). It is not recommended for use on Windows NT systems. Please note that this programming software does not meet the Arizona Microchip Technology verification requirements for a "production quality" programmer. Also, it does not support the programming of ID locations.

The user interface consists of two windows. The top window contains the operating instructions and the bottom window shows the command line and data communications with the PIC μ C. When the top window first appears the user will be prompted to enter the number of the serial communications port to which the EV6120 board is connected, and then, which device is programmed. For the EV6120 select option 1, PIC16C74A. Once the user has entered this number, the following commands may be selected:

```
press F    to load file.
press C    to configure device.
press B    to check target device is blank.
press P    to program target device.
press V    to verify target device.
press R    to read target device.
press A    to view contents of program data array.
press Esc  to return to DOS.
```

A new function from the above table can be selected whenever the **>ok** prompt appears in the bottom window.

Notes:

- a) Assembler output files must be in the Intel hex format (**.HEX**) in order to be usable by this programming software.
- b) The PIC μ C supplied has a Configuration Word which is preset **3FB1H**. This selects the crystal oscillator, disables the watch dog timer, enables the power up timer and disables code protection. The programming software currently defaults to **3FB1H**. Consult Arizona Microchip Technology for more information on the Configuration Word.

- c) The "blank check" command **(B)** only looks at the first location. A programmed device will always have data in this location as it is the program start address.
- d) For each of the commands **B, P, R** and **v** the user will be prompted to manually reset the target μC , by pressing the RESET switch (SW5) on the EV6120 Evaluation Board. This is because PIC programming always starts from location 0000 and the program counter can only be incremented.
- e) Pressing **A** will display the program data in the bottom window, formatted in pages of 48 consecutive locations. Use the **<PageUp>** and **<PageDown>** keys to scroll through the data. Pressing **<Esc>** will return the user to the **>ok** prompt.

TO LEAVE PROGRAMMING MODE

- (a) Remove power from board (including the programming voltage, V_{PP}).
- (b) Power up board as described in previous sections for normal operation.

1.7 Performance Specification

1.7.1 Electrical Performance

Absolute Maximum Ratings

Exceeding these maximum ratings can result in damage to the Evaluation Kit.

	Min.	Max.	Units
Supply ($V_{IN} - V_{SS}$)	-0.3	40.0	V
Supply ($V_{DD} - V_{SS}$)	-0.3	7.0	V
Voltage on any pin to V_{SS}	-0.3	$V_{DD} + 0.3$	V
Current into or out of V_{IN} and V_{SS} pins	0	+1.5	A
Current into or out of any other pin	-20	+20	mA
Storage Temperature	-	+70	°C
Operating Temperature	+10	+35	°C

Operating Limits

Correct operation of the Evaluation Kit outside these limits is not implied.

	Notes	Min.	Max.	Units
Supply ($V_{IN} - V_{SS}$)		8.0	24.0	V
Supply ($V_{DD} - V_{SS}$)		3.0	5.5	V
Operating Temperature		+10	+35	°C
External Clock Frequency for CMX612		3.575965	3.583125	MHz
External Clock Frequency (for μC at 5.0V V_{DD})		0.1	20.0	MHz
External Clock Frequency (for μC at 3.0V V_{DD})		0.1	4.0	MHz

Operating Characteristics

For the following conditions unless otherwise specified:

Evaluation Device and DTMF Generator Xtal Frequency = 3.579545MHz, μC = 4.00MHz

V_{DD} = 3.3V to 5.0V, T_{amb} = +25°C.

	Notes	Min.	Typ.	Max.	Units
DC Parameters					
I_{DD} (evaluation board - idle)	1	-	50.0	-	mA
AC Parameters					
Xtal/Clock Input to Evaluation Device					
'High' pulse width	2	100	-	-	ns
'Low' pulse width	2	100	-	-	ns
OSC1 Input to PIC μC					
'High' pulse width		50.0	-	-	ns
'Low' pulse width		50.0	-	-	ns

- Notes:**
1. Relays not energised.
 2. Timing for an external input to the CLOCK/XTAL pin.

Operating Characteristics - Timing Diagrams

For CMX612 timing information, refer to current CML CMX612 Data Sheet.

CML does not assume any responsibility for the use of any circuitry described. No IPR or circuit patent licences are implied. CML reserves the right at any time without notice to change the said circuitry and this evaluation kit specification. Evaluation kits are supplied for the sole purpose of demonstrating the operation of CML products and are supplied without warranty. They are intended for use in a laboratory environment only and are not for re-sale, end-use or incorporation into other equipments. Operation of evaluation kits outside a laboratory environment is not permitted within the European Community. All software is supplied "as is" and is without warranty. It forms part of the evaluation kit and is licensed for use only in this kit, for the purpose of demonstrating the operation of CML products. Whilst all reasonable efforts are made to ensure that software contained in this product is virus free, CML accepts no responsibility whatsoever for any contamination which results from using this software and the onus for checking that the software is virus free is placed on the purchaser of this evaluation kit.



**Oval Park - LANGFORD
MALDON - ESSEX
CM9 6WG - ENGLAND**

**Telephone: +44 (0)1621 875500
Telefax: +44 (0)1621 875600
e-mail: sales@cmlmicro.co.uk
<http://www.cmlmicro.co.uk>**