

# Customer Information Sheet

DRAWING No.: M80-463XXXX

SHEET 2 OF 2

IF IN DOUBT - ASK

©

NOT TO SCALE

THIRD ANGLE PROJECTION

ALL DIMENSIONS IN mm

**SPECIFICATIONS:**

**MATERIAL:**  
 Moulding = GLASS-FILLED PPS, UL94V-0, BLACK  
 CONTACT CLIP = BERYLLIUM COPPER  
 CONTACT SHELL = BRASS  
 JACKSCREW, NUT = STAINLESS STEEL

**FINISH:**  
 05 = 0.3µ GOLD CLIP, 0.25-0.3µ GOLD SHELL  
 42 = 0.3µ GOLD CLIP, 3.5-5.0µ 100% TIN OVER NICKEL SHELL

**ELECTRICAL:**  
 CURRENT RATING AT 25°C = 3.0A MAX  
 CURRENT RATING AT 85°C = 2.2A MAX  
 WORKING VOLTAGE = 120V AC/DC  
 VOLTAGE PROOF = 360V AC/DC  
 CONTACT RESISTANCE = 25 mΩ MAX  
 INSULATION RESISTANCE = 100 MΩ MIN

**MECHANICAL:**  
 DURABILITY = 500 OPERATIONS  
 INSERTION FORCE (∅0.5mm GAUGE) = 2.8N MAX  
 WITHDRAWAL FORCE (∅0.5mm GAUGE) = 0.2N MIN

**ENVIRONMENTAL:**  
 TEMPERATURE RANGE = -55°C TO +125°C

**PACKING:**  
 LOOSE  
 FOR COMPLETE SPECIFICATION, SEE COMPONENT SPECIFICATION C005XX (LATEST ISSUE)

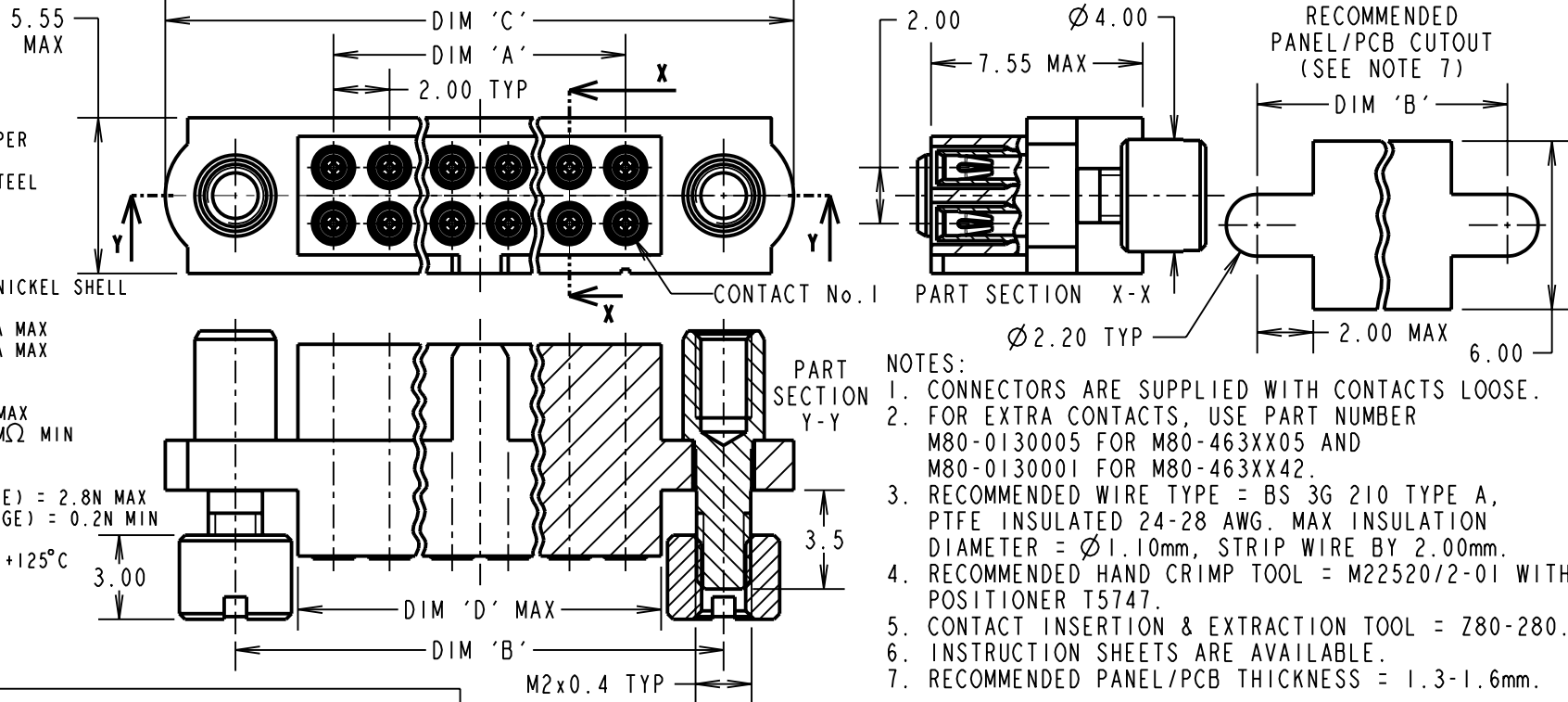

- NOTES:**
- CONNECTORS ARE SUPPLIED WITH CONTACTS LOOSE.
  - FOR EXTRA CONTACTS, USE PART NUMBER M80-0130005 FOR M80-463XX05 AND M80-0130001 FOR M80-463XX42.
  - RECOMMENDED WIRE TYPE = BS 3G 210 TYPE A, PTFE INSULATED 24-28 AWG. MAX INSULATION DIAMETER = ∅1.10mm, STRIP WIRE BY 2.00mm.
  - RECOMMENDED HAND CRIMP TOOL = M22520/2-01 WITH POSITIONER T5747.
  - CONTACT INSERTION & EXTRACTION TOOL = Z80-280.
  - INSTRUCTION SHEETS ARE AVAILABLE.
  - RECOMMENDED PANEL/PCB THICKNESS = 1.3-1.6mm.

DIMENSION	CALCULATION
DIM 'A'	TOTAL No. OF CONTACTS - 2
DIM 'B'	TOTAL No. OF CONTACTS + 5
DIM 'C'	TOTAL No. OF CONTACTS + 10
DIM 'D'	TOTAL No. OF CONTACTS + 0.64

EXAMPLE: CONNECTOR WITH 20 CONTACTS, GOLD CLIP AND 100% TIN OVER NICKEL SHELL, M80-4632042

DIM 'A' = 18.00mm, DIM 'B' = 25.00mm,  
 DIM 'C' = 30.00mm, DIM 'D' = 20.64mm

ORDER CODE:

**M80-463XXXX**

TOTAL No. OF CONTACTS  
 06, 10, 12, 14, 20,  
 26, 34, 42, 50

FINISH CODE

05 - GOLD CLIP, GOLD SHELL  
 42 - GOLD CLIP, 100% TIN OVER NICKEL SHELL

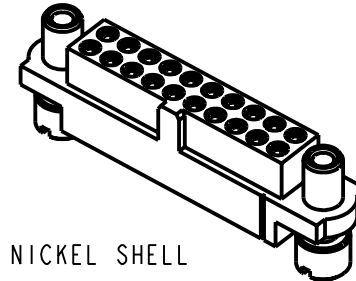

CP	1	01.09.10	10870
NAME	ISS.	DATE	C/NOTE
APPROVED: C.PENROSE			
CHECKED: R.ADDE			
DRAWN: B. M. KENT			
CUSTOMER REF.:			
ASSEMBLY DRG:			

**HARWIN**

HARWIN USA  
 TEL: 603 893 5376  
 FAX: 603 893 5396  
 mis@harwin.com

HARWIN Europe (UK)  
 TEL: 023 9231 4545  
 FAX: 023 9231 4590  
 mis@harwin.co.uk

HARWIN Asia  
 TEL: +65 6 779 4909  
 FAX: +65 6 779 3868  
 mis@harwin.com.sg

THIS DRAWING AND ANY INFORMATION OR DESCRIPTIVE MATTER SET OUT HEREON ARE CONFIDENTIAL AND COPYRIGHT PROPERTY OF THE HARWIN GROUP AND MUST NOT BE DISCLOSED, LOANED, COPIED OR USED FOR MANUFACTURING, TENDERING OR FOR ANY OTHER PURPOSE WITHOUT THEIR WRITTEN PERMISSION.

**TOLERANCES**  
 X. = ±1mm  
 X.X = ±0.25mm  
 X.XX = ±0.10mm  
 X.XXX = ±0.01mm

ANGLES = ±5°  
 UNLESS STATED

**MATERIAL:**  
 SEE ABOVE

**FINISH:**  
 SEE ABOVE

**S/AREA:**  
 mm<sup>2</sup>

**TITLE:** DATAMATE J-TEK  
 FEMALE DIL SMALL BORE CRIMP WITH  
 'REVERSE FIX' JACKSCREW AND  
 3.5mm BOARD/PANEL MOUNT

**DRAWING NUMBER:**  
**M80-463XXXX**

SHT  
 2 OF 2