

T-SMINTI
4B3T Second Gen.
Modular ISDN NT
(Intelligent)

PEF 82902 Version 1.1

Wired
Communications



Never stop thinking.

Edition 2001-11-09

**Published by Infineon Technologies AG,
St.-Martin-Strasse 53,
D-81541 München, Germany**

**© Infineon Technologies AG 2001.
All Rights Reserved.**

Attention please!

The information herein is given to describe certain components and shall not be considered as warranted characteristics.

Terms of delivery and rights to technical change reserved.

We hereby disclaim any and all warranties, including but not limited to warranties of non-infringement, regarding circuits, descriptions and charts stated herein.

Infineon Technologies is an approved CECC manufacturer.

Information

For further information on technology, delivery terms and conditions and prices please contact your nearest Infineon Technologies Office in Germany or our Infineon Technologies Representatives worldwide (see address list).

Warnings

Due to technical requirements components may contain dangerous substances. For information on the types in question please contact your nearest Infineon Technologies Office.

Infineon Technologies Components may only be used in life-support devices or systems with the express written approval of Infineon Technologies, if a failure of such components can reasonably be expected to cause the failure of that life-support device or system, or to affect the safety or effectiveness of that device or system. Life support devices or systems are intended to be implanted in the human body, or to support and/or maintain and sustain and/or protect human life. If they fail, it is reasonable to assume that the health of the user or other persons may be endangered.

T-SMINTI

4B3T Second Gen.

Modular ISDN NT

(Intelligent)

PEF 82902 Version 1.1

**Wired
Communications**



Never stop thinking.

Page	Subjects (major changes since last revision)
Table 18 Figure 41 Chapter 2.4.7.4	Additional C/I-command LTD
Chapter 3.2.3 Chapter 4.3 Chapter 4.9.4	The Framer / Deframer Loopback (DLB) is no more supported
Chapter 4.3	Reset value of MASKU is FFh (not 00h)
Chapter 4.3 Chapter 4.9.8	Reset value of FW-Version is 3Eh
Chapter 4.9.4	Restriction of LOOP.LB1, LB2 and LBBD to Transparent state
Chapter 5.2	Input Leakage Current AIN, BIN: max. 30 μ A
Chapter 5.4	Reduced power consumption

For questions on technology, delivery and prices please contact the Infineon Technologies Offices in Germany or the Infineon Technologies Companies and Representatives worldwide: see our webpage at <http://www.infineon.com>

Table of Contents		Page
1	Overview	1
1.1	References	2
1.2	Features	3
1.3	Not Supported are	4
1.4	Pin Configuration	5
1.5	Block Diagram	6
1.6	Pin Definitions and Functions	7
1.6.1	Specific Pins and Test Modes	12
1.7	System Integration	13
2	Functional Description	16
2.1	Microcontroller Interfaces	16
2.1.1	Serial Control Interface (SCI)	16
2.1.1.1	Programming Sequences	19
2.1.2	Parallel Microcontroller Interface	21
2.1.3	Microcontroller Clock Generation	23
2.2	Reset Generation	23
2.3	IOM [®] -2 Interface	27
2.3.1	IOM,-2 Functional Description	27
2.3.2	IOM,-2 Handler	28
2.3.2.1	Controller Data Access (CDA)	30
2.3.2.2	Serial Data Strobe Signal	40
2.3.3	IOM,-2 Monitor Channel	41
2.3.3.1	Handshake Procedure	41
2.3.3.2	Error Treatment	45
2.3.3.3	MONITOR Channel Programming as a Master Device	47
2.3.3.4	MONITOR Channel Programming as a Slave Device	47
2.3.3.5	Monitor Time-Out Procedure	48
2.3.3.6	MONITOR Interrupt Logic	48
2.3.4	C/I Channel Handling	49
2.3.5	D-Channel Access Control	51
2.3.5.1	Application Examples for D-Channel Access Control	51
2.3.5.2	TIC Bus Handling	52
2.3.5.3	Stop/Go Bit Handling	53
2.3.5.4	D-Channel Arbitration	54
2.3.5.5	State Machine of the D-Channel Arbiter	55
2.3.6	Activation/Deactivation of IOM [®] -2 Interface	57
2.4	U-Transceiver	59
2.4.1	4B3T Frame Structure	59
2.4.2	Maintenance Channel	63
2.4.3	Coding from Binary to Ternary Data	63
2.4.4	Decoding from Ternary to Binary Data	64
2.4.4.1	Monitoring of Code Violations	65

Table of Contents		Page
2.4.4.2	Block Error Counter (RDS Error Counter)	65
2.4.5	Scrambler / Descrambler	66
2.4.6	Command/Indication Codes	66
2.4.7	State Machine for Activation and Deactivation	67
2.4.7.1	State Machine Notation	67
2.4.7.2	Awake Protocol	68
2.4.7.3	NT State Machine (IEC-T / NTC-T Compatible)	71
2.4.7.4	Inputs to the U-Transceiver	72
2.4.7.5	Outputs of the U-Transceiver	74
2.4.7.6	NT-States	75
2.4.8	U-Transceiver Interrupt Structure	77
2.5	S-Transceiver	79
2.5.1	Line Coding, Frame Structure	79
2.5.2	S/Q Channels, Multiframeing	81
2.5.3	Data Transfer between IOM,-2 and S0	82
2.5.4	Loopback 2	82
2.5.5	Control of S-Transceiver / State Machine	82
2.5.5.1	C/I Codes	85
2.5.5.2	State Machine NT Mode	87
2.5.5.3	State Machine LT-S Mode	91
2.5.6	S-Transceiver Enable / Disable	94
2.5.7	Interrupt Structure S-Transceiver	95
3	Operational Description	96
3.1	Layer 1 Activation/Deactivation	96
3.1.1	Generation of 4B3T Signal Elements	96
3.1.2	Complete Activation Initiated by Exchange	99
3.1.3	Complete Activation Initiated by TE	100
3.1.4	Complete Activation Initiated by NT	101
3.1.5	Complete Deactivation	102
3.1.6	Loop 2	103
3.2	Layer 1 Loopbacks	104
3.2.1	Analog Loop-Back S-Transceiver	104
3.2.2	Loopback No.2	105
3.2.2.1	Complete Loopback	106
3.2.2.2	Loopback No.2 - Single Channel Loopbacks	106
3.2.3	Local Loopbacks Featured By the LOOP Register	106
3.3	External Circuitry	108
3.3.1	Power Supply Blocking Recommendation	108
3.3.2	U-Transceiver	108
3.3.3	S-Transceiver	110
3.3.4	Oscillator Circuitry	113
3.3.5	General	113

Table of Contents		Page
4	Register Description	114
4.1	Address Space	114
4.2	Interrupts	114
4.3	Register Summary	116
4.3.1	Reset of U-Transceiver Functions During Deactivation or with C/I-Code RESET 122	
4.3.2	Mode Register Evaluation Timing	123
4.4	Detailed C/I Registers	124
4.4.1	MODEH - Mode Register IOM-2	124
4.4.2	CIR0 - Command/Indication Receive 0	124
4.4.3	CIX0 - Command/Indication Transmit 0	126
4.4.4	CIR1 - Command/Indication Receive 1	126
4.4.5	CIX1 - Command/Indication Transmit 1	127
4.5	Detailed S-Transceiver Registers	128
4.5.1	S_CONF0 - S-Transceiver Configuration Register 0	128
4.5.2	S_CONF2 - S-Transmitter Configuration Register 2	129
4.5.3	S_STA - S-Transceiver Status Register	129
4.5.4	S_CMD - S-Transceiver Command Register	130
4.5.5	SQRR - S/Q-Channel Receive Register	131
4.5.6	SQXR- S/Q-Channel Transmit Register	132
4.5.7	ISTAS - Interrupt Status Register S-Transceiver	133
4.5.8	MASKS - Mask S-Transceiver Interrupt	134
4.5.9	S_MODE - S-Transceiver Mode	134
4.6	Interrupt and General Configuration Registers	135
4.6.1	ISTA - Interrupt Status Register	135
4.6.2	MASK - Mask Register	136
4.6.3	MODE1 - Mode1 Register	137
4.6.4	MODE2 - Mode2 Register	139
4.6.5	ID - Identification Register	139
4.6.6	SRES - Software Reset Register	140
4.7	Detailed IOM [®] -2 Handler Registers	140
4.7.1	CDAXy - Controller Data Access Register xy	140
4.7.2	XXX_TSDPxy - Time Slot and Data Port Selection for CHxy	141
4.7.3	CDAX_CR - Control Register Controller Data Access CH1x	142
4.7.4	S_CR - Control Register S-Transceiver Data	143
4.7.5	CI_CR - Control Register for CI1 Data	144
4.7.6	MON_CR - Control Register Monitor Data	145
4.7.7	SDS1_CR - Control Register Serial Data Strobe 1	146
4.7.8	SDS2_CR - Control Register Serial Data Strobe 2	147
4.7.9	IOM_CR - Control Register IOM Data	148
4.7.10	MCDA - Monitoring CDA Bits	149
4.7.11	STI - Synchronous Transfer Interrupt	149

Table of Contents		Page
4.7.12	ASTI - Acknowledge Synchronous Transfer Interrupt	150
4.7.13	MSTI - Mask Synchronous Transfer Interrupt	151
4.8	Detailed MONITOR Handler Registers	151
4.8.1	MOR - MONITOR Receive Channel	151
4.8.2	MOX - MONITOR Transmit Channel	152
4.8.3	MOSR - MONITOR Interrupt Status Register	152
4.8.4	MOCR - MONITOR Control Register	153
4.8.5	MSTA - MONITOR Status Register	154
4.8.6	MCONF - MONITOR Configuration Register	154
4.9	Detailed U-Transceiver Registers	155
4.9.1	OPMODE - Operation Mode Register	155
4.9.2	UCIR - C/I Code Read Register	155
4.9.3	UCIW - C/I Code Write Register	155
4.9.4	LOOP - Loopback Register	156
4.9.5	RDS - Block Error Counter Register	157
4.9.6	ISTAU - Interrupt Status Register U-Interface	157
4.9.7	MASKU - Mask Register U-Interface	158
4.9.8	FW_VERSION	159
5	Electrical Characteristics	160
5.1	Absolute Maximum Ratings	160
5.2	DC Characteristics	161
5.3	Capacitances	163
5.4	Power Consumption	163
5.5	Supply Voltages	163
5.6	AC Characteristics	165
5.6.1	IOM [®] -2 Interface	166
5.6.2	Serial μ P Interface	168
5.6.3	Parallel μ P Interface	169
5.6.4	Reset	173
5.6.5	Undervoltage Detection Characteristics	174
6	Package Outlines	176
7	Appendix: Differences between Q- and T-SMINT,I	178
7.1	Pinning	179
7.1.1	Pin Definitions and Functions	179
7.1.2	LED Pin ACT	179
7.2	U-Transceiver	180
7.2.1	U-Interface Conformity	180
7.2.2	U-Transceiver State Machines	181
7.2.3	Command/Indication Codes	184
7.2.4	Interrupt Structure	185
7.2.5	Register Summary U-Transceiver	187

Table of Contents		Page
7.3	External Circuitry	190
8	Index	191

List of Figures		Page
Figure 1	Pin Configuration	5
Figure 2	Block Diagram	6
Figure 3	Application Example T-SMINT [®] I: High Feature Intelligent NT.	13
Figure 4	Control via μ P Interface	14
Figure 5	Control via IOM,-2 Interface	15
Figure 6	Serial Control Interface Timing	18
Figure 7	Serial Command Structure.	19
Figure 8	Direct/Indirect Register Address Mode	22
Figure 9	Reset Generation of the T-SMINT,I	24
Figure 10	IOM [®] -2 Frame Structure of the T-SMINT,I	27
Figure 11	Architecture of the IOM,-2 Handler	29
Figure 12	Data Access via CDAX0 and CDAX1 register pairs	31
Figure 13	Examples for Data Access via CDAXy Registers.	32
Figure 14	Data Access when Looping TSa from DU to DD	33
Figure 15	Data Access when Shifting TSa to TSb on DU (DD).	34
Figure 16	Example for Monitoring Data	35
Figure 17	Interrupt Structure of the Synchronous Data Transfer.	38
Figure 18	Examples for the Synchronous Transfer Interrupt Control with one STIxy enabled.	39
Figure 19	Data Strobe Signal Generation	40
Figure 20	MONITOR Channel Protocol (IOM [®] -2)	43
Figure 21	Monitor Channel, Transmission Abort requested by the Receiver.	46
Figure 22	Monitor Channel, Transmission Abort requested by the Transmitter.	46
Figure 23	Monitor Channel, Normal End of Transmission	46
Figure 24	MONITOR Interrupt Structure	49
Figure 25	CIC Interrupt Structure.	50
Figure 26	D-Channel Arbitration: μ C with HDLC and Direct Access to TIC Bus	51
Figure 27	D-Channel Arbitration: μ C with HDLC and no Access to TIC Bus	52
Figure 28	Structure of Last Octet of Ch2 on DU	53
Figure 29	Structure of Last Octet of Ch2 on DD	54
Figure 30	State Machine of the D-Channel Arbiter (Simplified View).	56
Figure 31	Deactivation of the IOM [®] -2 Clocks	58
Figure 32	State Diagram Example	68
Figure 33	Awake Procedure initiated by the LT	69
Figure 34	Awake Procedure initiated by the NT.	69
Figure 35	NT State Machine (IEC-T/NTC-T Compatible).	71
Figure 36	Interrupt Structure U-Transceiver	78
Figure 37	S/T -Interface Line Code	79
Figure 38	Frame Structure at Reference Points S and T (ITU I.430).	80
Figure 39	S-Transceiver Control	83
Figure 40	State Diagram Notation	84
Figure 41	State Machine NT Mode	87

List of Figures		Page
Figure 42	State Machine LT-S Mode	91
Figure 43	Interrupt Structure S-Transceiver.	95
Figure 44	Activation Initiated by Exchange	99
Figure 45	Activation Initiated by TE	100
Figure 46	Activation Initiated by NT	101
Figure 47	Complete Deactivation.	102
Figure 48	Loop 2	103
Figure 49	Test Loopbacks	104
Figure 50	External Loop at the S/T-Interface	105
Figure 51	Complete Loopback Options in NT-Mode	106
Figure 52	Loopbacks Featured by Register LOOP	107
Figure 53	Power Supply Blocking	108
Figure 54	External Circuitry U-Transceiver with External Hybrid.	109
Figure 55	External Circuitry S-Interface Transmitter	112
Figure 56	External Circuitry S-Interface Receiver	112
Figure 57	Crystal Oscillator	113
Figure 58	Address Space.	114
Figure 59	T-SMINT,I Interrupt Status Registers.	115
Figure 60	Maximum Sinusoidal Ripple on Supply Voltage	164
Figure 61	Input/Output Waveform for AC Tests.	165
Figure 62	IOM [®] -2 Interface - Bit Synchronization Timing	166
Figure 63	IOM [®] -2 Interface - Frame Synchronization Timing	166
Figure 64	Serial Control Interface	168
Figure 65	Microprocessor Read Cycle.	169
Figure 66	Microprocessor Write Cycle	169
Figure 67	Multiplexed Address Timing.	169
Figure 68	Non-Multiplexed Address Timing.	170
Figure 69	Microprocessor Read Timing.	170
Figure 70	Microprocessor Write Cycle	170
Figure 71	Non-Multiplexed Address Timing.	171
Figure 72	Reset Input Signal	173
Figure 73	Undervoltage Control Timing.	174
Figure 74	NTC-Q Compatible State Machine Q-SMINT,I: 2B1Q	181
Figure 75	Simplified State Machine Q-SMINT,I: 2B1Q	182
Figure 76	IEC-T/NTC-T Compatible State Machine T-SMINT,I: 4B3T.	183
Figure 77	Interrupt Structure U-Transceiver Q-SMINT,I: 2B1Q	185
Figure 78	Interrupt Structure U-Transceiver T-SMINT,I: 4B3T.	186
Figure 79	External Circuitry Q- and T-SMINT,I	190

List of Tables	Page
Table 1	NT Products of the 2nd Generation 1
Table 2	Pin Definitions and Functions 7
Table 3	ACT States. 12
Table 4	Interface Selection for the T-SMINT,I. 16
Table 5	Header Byte Code 19
Table 6	Bus Operation Modes 21
Table 7	MCLK Frequencies 23
Table 8	Reset Source Selection 25
Table 9	Examples for Synchronous Transfer Interrupts 37
Table 10	Transmit Direction 42
Table 11	Receive Direction. 42
Table 12	T-SMINT,I Configuration Settings in Intelligent NT Applications 55
Table 13	Frame Structure A for Downstream Transmission LT to NT 61
Table 14	Frame Structure B for Upstream Transmission NT to LT. 62
Table 15	MMS 43 Coding Table 63
Table 16	4B3T Decoding Table 64
Table 17	Active States 65
Table 18	C/I Codes. 66
Table 19	Differences to the former NT-SM of the IEC-T/NTC-T. 72
Table 20	Timers 73
Table 21	M Symbol Output 75
Table 22	Signal Output on Uk0 in State Test 75
Table 23	C/I-Code Output. 75
Table 24	S/Q-Bit Position Identification and Multi-Frame Structure 81
Table 25	4B3T Signal Elements 96
Table 26	Generation of the 4B3T Signal Elements. 97
Table 27	S/T-Interface Signals 98
Table 28	U-Transformer Parameters 109
Table 29	S-Transformer Parameters 111
Table 30	Crystal Parameters 113
Table 31	Reset of U-Transceiver Functions During Deactivation or with C/I-Code RESET 123
Table 32	Mode Register with Immediate Evaluation and Execution. 123
Table 33	Maximum Input Currents 160
Table 34	S-Transceiver Characteristics 161
Table 35	U-Transceiver Characteristics 162
Table 36	Pin Capacitances 163
Table 37	Reset Input Signal Characteristics. 173
Table 38	Parameters of the UVD/POR Circuit 174
Table 39	Design Number 178
Table 41	ACT States. 179

1 Overview

The **PEB 82902** (T-SMINT[®]I) offers U-transceiver, S-transceiver and an IOM[®]-2 interface. A microcontroller interface provides access to both transceivers as well as the IOM[®]-2 interface.

However, as opposed to its bigger brother T-SMINT[®]IX, the T-SMINT[®]I does not have an HDLC controller. Main target applications of the T-SMINT[®]I are intelligent NT applications where the HDLC controller(s) is (are) provided by the microcontroller. An example for such a microcontroller is the Infineon UTAH chip which features four flexible HDLC controllers.

Table 1 on **Page 1** summarizes the 2nd generation NT products.

Table 1 NT Products of the 2nd Generation

	PEF 80902	PEF 81902	PEF 82902
	T-SMINT[®]O	T-SMINT[®]IX	T-SMINT[®]I
Package	P-MQFP-44	P-MQFP-64 P-TQFP-64	P-MQFP-64 P-TQFP-64
Register access	no	U+S+HDLC+ IOM [®] -2	U+S+IOM [®] -2
Access via	n.a	parallel (or SCI or IOM [®] -2)	parallel (or SCI or IOM [®] -2)
MCLK, watchdogtimer, SDS, BCL, D-channel arbitration, IOM [®] -2 access and manipulation etc. provided	no	yes	yes
HDLC controller	no	yes	no
NT1 mode available	yes (only)	no	no

1.1 References

- [1] TS 102 080, Transmission and Multiplexing; ISDN basic rate access; Digital transmission system on metallic local lines, ETSI, November 1998
- [2] FTZ 1 TR 220 Technische Richtlinie, Spezifikation der ISDN Schnittstelle Uk0 Schicht 1, Deutsche Telecom AG, August 1991
- [3] TS 0284/96 Technische Spezifikation Intelligenter Netzabschluß (iNT) mit den Funktionen eines Terminaladapters TA 2a/b (ohne Internverkehr), Deutsche Telekom AG, März 2001
- [4] pr ETS 300 012 Draft, ISDN; Basic User Network Interface (UNI), ETSI, November 1996
- [5] T1.605-1991, ISDN-Basic Access Interface for S and T Reference Points (Layer 1 Specification), ANSI, 1991
- [6] I.430, ISDN User-Network Interfaces: Layer 1 Recommendations, ITU, November 1988
- [7] IEC-T, ISDN Echocancellation Circuit, PEB 20901 (IEC - TD) / PEB 20902 (IEC - TA), preliminary Target Specification 11.88, Siemens AG, 1988
- [8] SBCX, S/T Bus Interface Circuit Extended, PEB 2081 V3.4, User's Manual 11.96, Siemens AG, 1996
- [9] NTC-T, Network Termination Controller (4B3T), PEB 8090 V1.1, Data Sheet 06.98, Siemens AG, 1998
- [10] INTC-Q, Intelligent Network Termination Controller (2B1Q), PEB 8191 V1.1, Data Sheet 10.97, Siemens AG, 1997
- [11] Q-SMINTO, 2B1Q Second Gen. **Modular ISDN NT (Ordinary)**, PEF 80912
Q-SMINTIX, 2B1Q Second Gen. **Modular ISDN NT (Intelligent eXtended)**, PEF 81912
Q-SMINTI, 2B1Q Second Gen. **Modular ISDN NT (Intelligent)**, PEF 82912 V1.3, Data Sheets 03.01, Infineon AG, 2001
- [12] IOM[®]-2 Interface Reference Guide, Siemens AG, 03.91
- [13] SCOUT-S(X), Siemens Codec with S/T-Transceiver, PSB 2138x V1.1, Preliminary Data Sheet 08.98, Infineon Technologies AG, 1999
- [14] PITA, PCI Interface for Telephony/Data Applications V0.3, SICAN GmbH, September 1997
- [15] Dual Channel SLICOFI-2, HV-SLIC; DUSLIC; PEB3265, 4265, 4266; Data Sheet DS2, Infineon Technologies, July 2000.

T-SMINT[®]I

4B3T Second Gen. Modular ISDN NT (Intelligent)

PEF 82902

Version 1.1

CMOS

1.2 Features

Features known from the PEB 8090

- U-transceiver and S-transceiver on one chip
- U-interface (4B3T) conform to ETSI [1] and FTZ [2]:
 - Meets all transmission requirements on all ETSI and FTZ loops with margin
- S/T-interface conform to ETSI [4], ANSI [5] and ITU [6]
 - Supports point-to-point and bus configurations
 - Meets and exceeds all transmission requirements
- Access to IOM[®]-2 C/I and Monitor channels
- Power-on reset and Undervoltage Detection with no external components
- ESD robustness 2kV

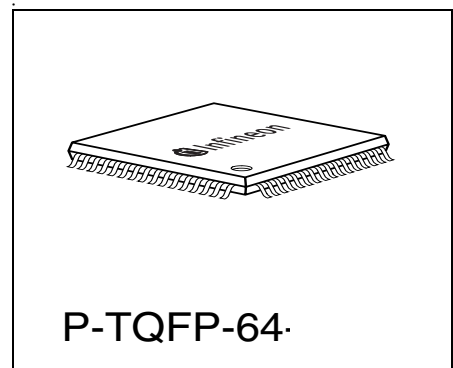
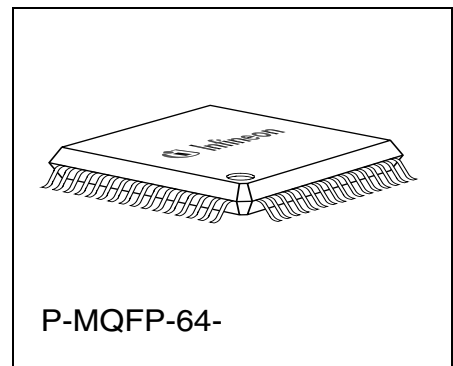

New Features

- Conforms to 'Technische Spezifikation Intelligenter Netzabschluß (iNT) mit den Funktionen eines Terminaladapters TA 2a/b' of Deutsche Telekom AG [3]
- Perfectly suited for high-end intelligent NTs that require multiple HDLC controllers
- Pin compatible with Q-SMINT[®]I (2nd Generation)
- Parallel or serial μ P-interface
 - Siemens/Intel non-multiplexed (direct or indirect addressing (SCOUT))
 - Siemens/Intel multiplexed
 - Motorola
 - programmable MCLK (can be disabled) (SCOUT)

Type	Package
PEF 82902	P-MQFP-64
PEF 82902	P-TQFP-64

- Enhanced IOM[®]-2 interface
 - Timeslot access and manipulation (SCOUT)
 - BCL output; programmable and flexible strobes SDS1/2, e.g. active during several timeslots.
 - Optional: All registers can be read and written to via new Monitor channel concept
 - External Awake ($\overline{\text{EAW}}$)
- Optional: Implementation of S-transceiver statemachine in software
- Power Down and reset states (e.g. S-transceiver) for individual circuits
- Automatic D-channel arbitration between S-bus and external HDLC controller
- Priority setting (8/10) for off-chip HDLC controller
- Pin Vref and the according external capacitor removed
- Inputs accept 3.3V and 5V
- I/O (open drain) accepts pull-up to 3.3V¹⁾
- Lowest power consumption due to
 - Low power CMOS technology (0.35 μ)
 - Newly optimized low power libraries
 - High output swing on U- and S-line interface leads to minimized power consumption
 - Single 3.3 Volt power supply

1.3 Not Supported are ...

- No integrated hybrid is provided by the T-SMINT[®]I. Therefore, an external hybrid is always required, which consists of only two additional resistors as compared to an integrated hybrid, but allows for more flexibility in board design.
- On-chip HDLC controller
- Auxiliary IOM[®]-2 interface
- SRA (capacitive receiver coupling is not suited for S-feeding)
- NT-Star with star point on the IOM[®]-2 bus (already not supported in NTC-T).
- No access to S2-5 channels. Access only to S1 and Q channel as in Scout-S. No selection between transparent and non-auto mode provided.

¹⁾ Pull-ups to 5V must be avoided. A so-called 'hot-electron-effect' would lead to long term degradation.

1.4 Pin Configuration

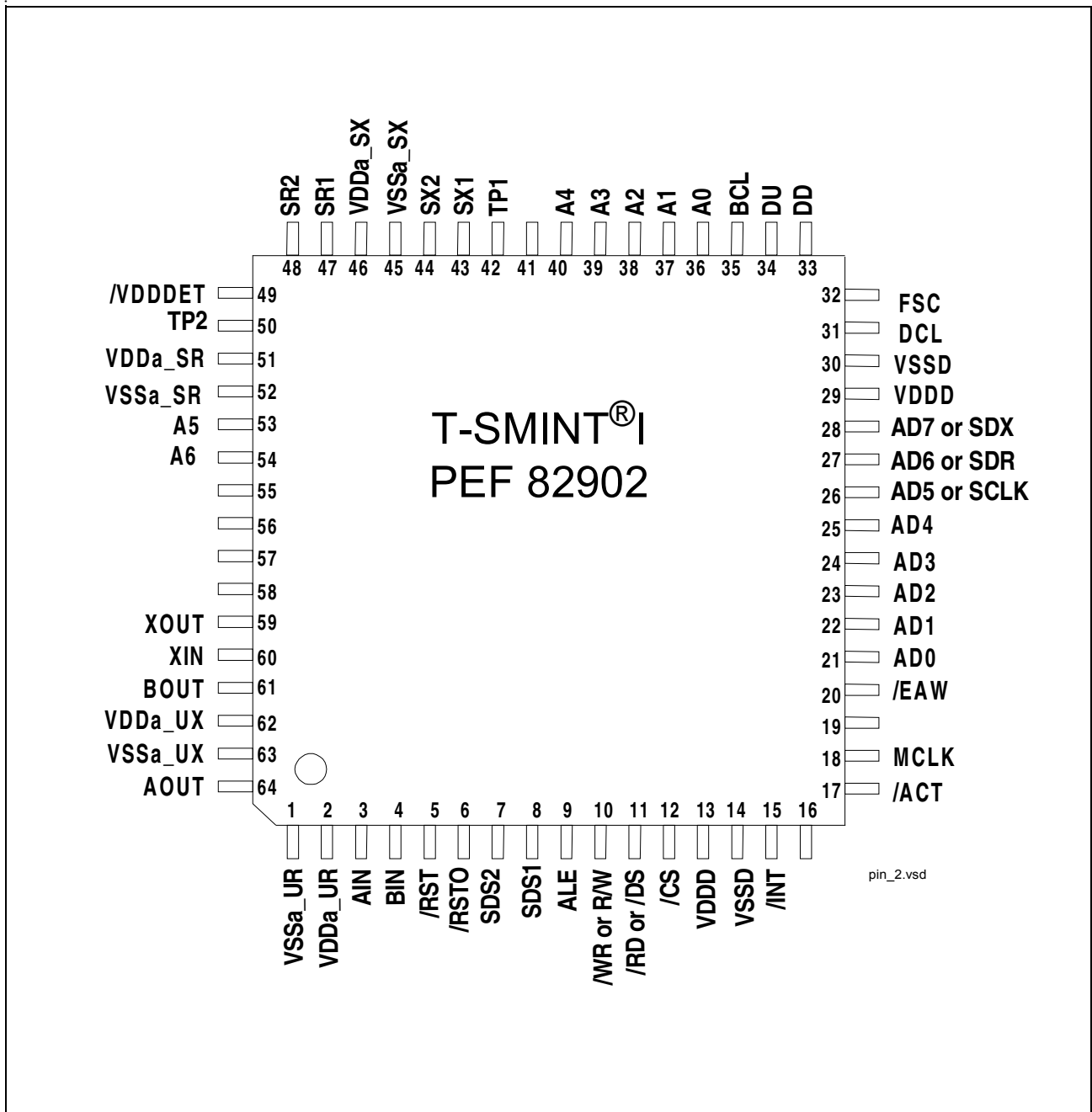

Figure 1 Pin Configuration

1.5 Block Diagram

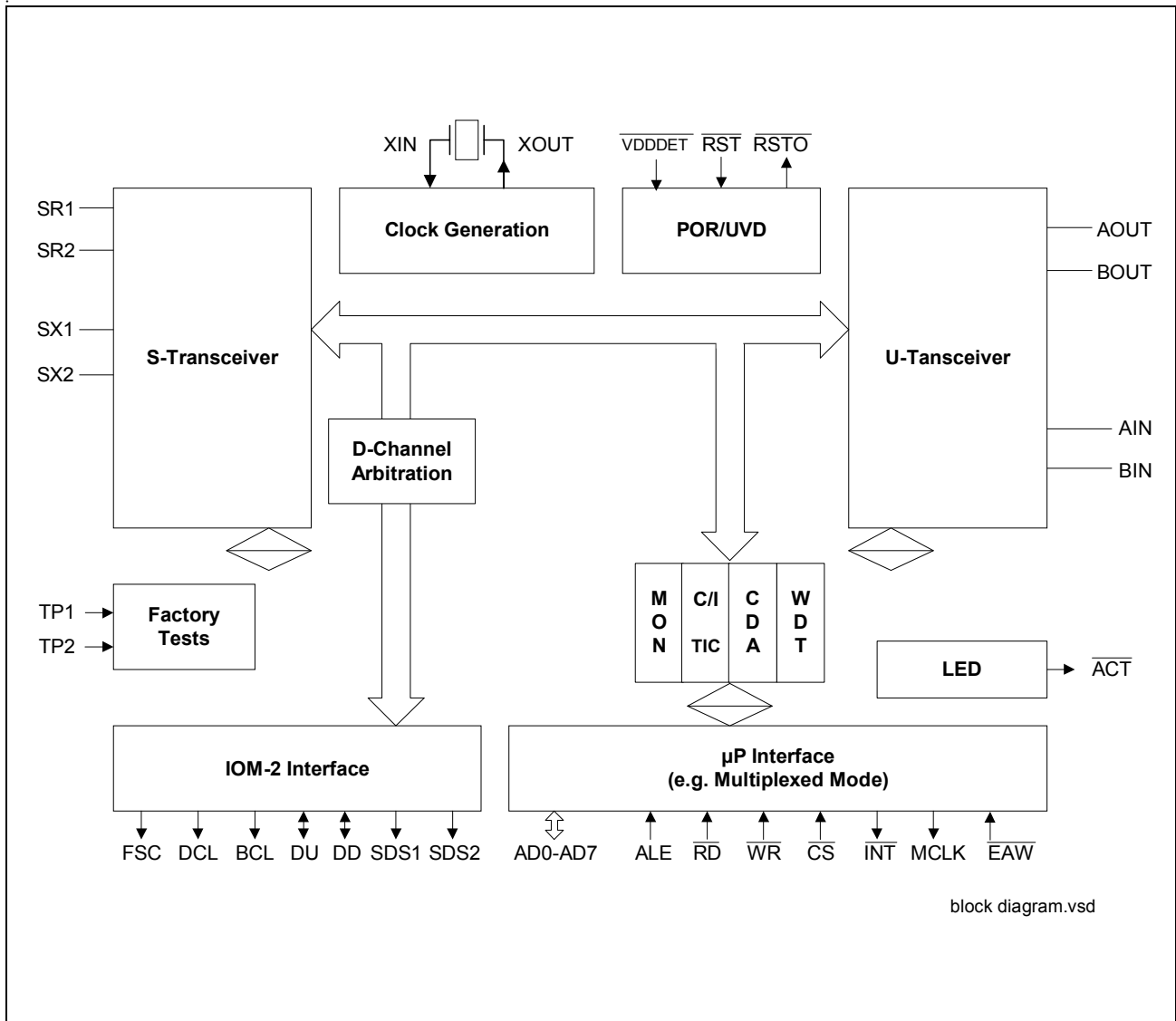

Figure 2 Block Diagram

1.6 Pin Definitions and Functions

Table 2 Pin Definitions and Functions

	Pin	Symbol	Type	Function
	2	VDDa_UR	–	Supply voltage for U-Receiver (3.3 V ± 5 %)
	1	VSSa_UR	–	Analog ground (0 V) U-Receiver
	62	VDDa_UX	–	Supply voltage for U-Transmitter (3.3 V ± 5 %)
	63	VSSa_UX	–	Analog ground (0 V) U-Transmitter
	51	VDDa_SR	–	Supply voltage for S-Receiver (3.3 V ± 5 %)
	52	VSSa_SR	–	Analog ground (0 V) S-Receiver
	46	VDDa_SX	–	Supply voltage for S-Transmitter (3.3 V ± 5 %)
	45	VSSa_SX	–	Analog ground (0 V) S-Transmitter
	29	VDDD	–	Supply voltage digital circuits (3.3 V ± 5 %)
	30	VSSD	–	Ground (0 V) digital circuits
	13	VDDD	–	Supply voltage digital circuits (3.3 V ± 5 %)
	14	VSSD	–	Ground (0 V) digital circuits
	32	FSC	O	Frame Sync: 8-kHz frame synchronization signal
	31	DCL	O	Data Clock: IOM [®] -2 interface clock signal (double clock): 1.536 MHz
	35	BCL	O	Bit Clock: The bit clock is identical to the IOM [®] -2 data rate (768 kHz)
	33	DD	I/O OD	Data Downstream: Data on the IOM [®] -2 interface
	34	DU	I/O OD	Data Upstream: Data on the IOM [®] -2 interface

Table 2 Pin Definitions and Functions (cont'd)

	Pin	Symbol	Type	Function
	8	SDS1	O	Serial Data Strobe1: Programmable strobe signal for time slot and/or D-channel indication on IOM [®] -2
	7	SDS2	O	Serial Data Strobe2: Programmable strobe signal for time slot and/or D-channel indication on IOM [®] -2
	12	$\overline{\text{CS}}$	I	Chip Select: A low level indicates a microcontroller access to the T-SMINT [®] I
	26	SCLK	I	Serial Clock: Clock signal of the SCI interface if a serial interface is selected
	26	AD5	I/O	Multiplexed Bus Mode: Address/data bus Address/data line AD5 if the parallel interface is selected Non-Multiplexed Bus Mode: Data bus Data line D5 if the parallel interface is selected
	27	SDR	I	Serial Data Receive: Receive data line of the SCI interface if a serial interface is selected
	27	AD6	I/O	Multiplexed Bus Mode: Address/data bus Address/data line AD6 if the parallel interface is selected Non-Multiplexed Bus Mode: Data bus Data line D6 if the parallel interface is selected

Table 2 Pin Definitions and Functions (cont'd)

	Pin	Symbol	Type	Function
	28	SDX	OD/O	Serial Data Transmit: Transmit data line of the SCI interface if a serial interface is selected
	28	AD7	I/O	Multiplexed Bus Mode: Address/data bus Address/data line AD7 if the parallel interface is selected Non-Multiplexed Bus Mode: Data bus Data line D7 if the parallel interface is selected
	21 22 23 24 25	AD0 AD1 AD2 AD3 AD4	I/O I/O I/O I/O I/O	Multiplexed Bus Mode: Address/data bus Transfers addresses from the microcontroller to the T-SMINT [®] I and data between the microcontroller and the T-SMINT [®] I. Non-Multiplexed Bus Mode: Data bus. Transfers data between the microcontroller and the T-SMINT [®] I (data lines D0-D4).
	36 37 38 39 40 53 54	A0 A1 A2 A3 A4 A5 A6	I I I I I I I	Non-Multiplexed Bus Mode: Address bus transfers addresses from the microcontroller to the T-SMINT [®] I. For indirect address mode only A0 is valid. Multiplexed Bus Mode Not used in multiplexed bus mode. In this case A0-A6 should directly be connected to VDD.
	11	$\overline{\text{RD}}$ $\overline{\text{DS}}$	I I	Read Indicates a read access to the registers (Intel bus mode). Data Strobe The rising edge marks the end of a valid read or write operation (Motorola bus mode).

Table 2 Pin Definitions and Functions (cont'd)

Pin	Symbol	Type	Function
10	\overline{WR} R/\overline{W}	I I	Write Indicates a write access to the registers (Intel bus mode). Read/Write A HIGH identifies a valid host access as a read operation and a LOW identifies a valid host access as a write operation (Motorola bus mode).
9	ALE	I	Address Latch Enable An address on the external address/data bus (multiplexed bus type only) is latched with the falling edge of ALE. ALE also selects the microcontroller interface type (multiplexed or non multiplexed).
5	\overline{RST}	I	Reset: Low active reset input. Schmitt-Trigger input with hysteresis of typical 360mV. Tie to '1' if not used.
6	\overline{RSTO}	OD	Reset Output: Low active reset output.
15	\overline{INT}	OD	Interrupt Request: \overline{INT} becomes active if the T-SMINT [®] I requests an interrupt.
18	MCLK	O	Microcontroller Clock: Clock output for the microcontroller
20	\overline{EAW}	I	External Awake: A low level on \overline{EAW} during power down activates the clock generation of the T-SMINT [®] I, i.e. the IOM [®] -2 interface provides FSC, DCL and BCL for read and write access. ¹⁾
43	SX1	O	S-Bus Transmitter Output (positive)
44	SX2	O	S-Bus Transmitter Output (negative)
47	SR1	I	S-Bus Receiver Input

Table 2 Pin Definitions and Functions (cont'd)

	Pin	Symbol	Type	Function
	48	SR2	I	S-Bus Receiver Input
	60	XIN	I	Crystal 1: Connected to a 15.36 MHz crystal
	59	XOUT	O	Crystal 2: Connected to a 15.36 MHz crystal
	64	AOUT	O	Differential U-interface Output
	61	BOUT	O	Differential U-interface Output
	3	AIN	I	Differential U-interface Input
	4	BIN	I	Differential U-interface Input
	49	$\overline{\text{VDDDET}}$	I	VDD Detection: This pin selects if the V_{DD} detection is active ('0') and reset pulses are generated on pin $\overline{\text{RSTO}}$ or whether it is deactivated ('1') and an external reset has to be applied on pin $\overline{\text{RST}}$.
	17	$\overline{\text{ACT}}$	O	Activation LED. Indicates the activation status of U- and S-transceiver. Can directly drive a LED (4mA).
	42	TP1	I	Test Pin 1. Used for factory device test. Tie to 'V _{SS} '
	50	TP2	I	Test Pin 2. Used for factory device test. Tie to 'V _{SS} '
	16, 19, 41, 55			Tie to '1'
	56, 57, 58	res		Reserved These pins are reserved for future use. Do not connect.

 1) This function of pin $\overline{\text{EAW}}$ is different to that defined in Ref. [13]

I: Input

O: Output (Push-Pull)

OD: Output (Open Drain)

1.6.1 Specific Pins and Test Modes

LED Pin $\overline{\text{ACT}}$

A LED can be connected to pin $\overline{\text{ACT}}$ to display four different states (off, slow flashing, fast flashing, on). It displays the activation status of the U- and S-transceiver according to [Table 3](#). or it is programmable via two bits (LED1 and LED2 in register MODE2).

Table 3 ACT States

Pin $\overline{\text{ACT}}$	LED	U_Deactivated	U_Activated	S_Activated
V _{DD}	OFF	1	x	x
2Hz (1 : 1)*	fast flashing	0	0	x
1Hz (3 : 1)*	slow flashing	0	1	0
GND	ON	0	1	1

Note: * denotes the duty cycle 'high' : 'low'.

with:

U_Deactivated: 'Deactivated State' as defined in [Chapter 2.4.7.6](#).

U_Activated: 'SBC Synchronizing', 'Wait for Info U4H', and 'Transparent' as defined in [Chapter 2.4.7.6](#).

S-Activated: 'Activated State' as defined in [Chapter 2.5.5.2](#).

Note: Optionally, pin $\overline{\text{ACT}}$ can drive a second LED with inverse polarity (connect this additional LED to 3.3V only).

Test Modes

The test patterns on the S-interface ('2 kHz Single Pulses', '96 kHz Continuous Pulses') and on the U-interface ('Data Through', 'Send Single Pulses',) are invoked via C/I codes (TM1, TM2, DT, SSP). Setting SRES.RES_U to '1' forces the U-transceiver into test mode 'Quiet Mode' (QM), i.e. the U-transceiver is hardware reset.

1.7 System Integration

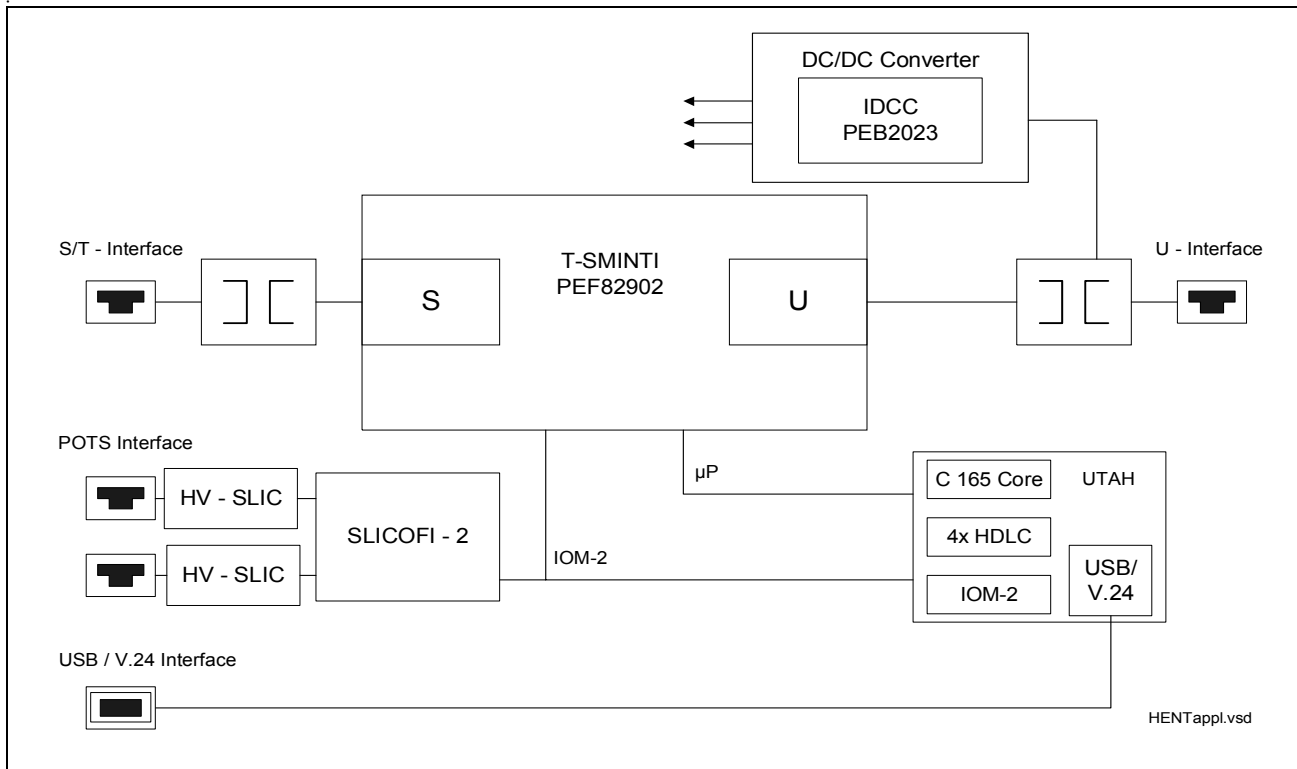

Figure 3 Application Example T-SMINT[®]I: High Feature Intelligent NT

The U-transceiver, the S-transceiver and the IOM[®]-2 channels can be controlled and monitored via:

- a) the parallel or serial microprocessor interface
 - Access of on-chip registers via µP interface Address/Data format
 - Activation/Deactivation control of U- and S-transceiver via µP interface and C/I handler
 - T-SMINT[®]I is Monitor channel master
 - TIC bus is transparent on IOM[®]-2 interface and is used for D-channel arbitration between S-transceiver and off-chip HDLC controllers.

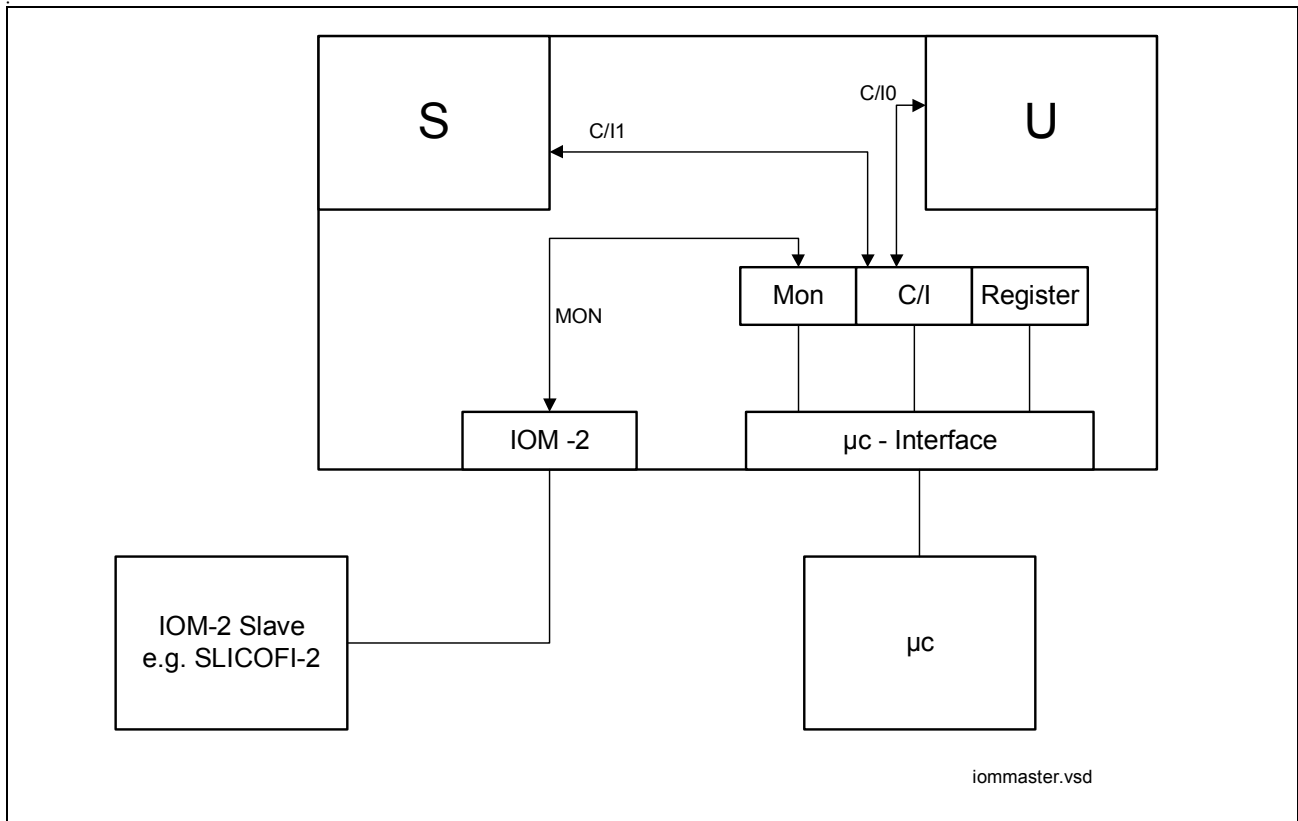

Figure 4 Control via μP Interface

Alternatively, the T-SMINT[®] can be controlled via

b) the IOM[®]-2 Interface

- Access of on-chip registers via the Monitor channel with Header/Address/Data format (Device is Monitor slave)
- Activation/Deactivation control of U- and S-transceiver via the C/I channels C/I0 and C/I1
- TIC bus is transparent on IOM[®]-2 interface and is used for D-channel arbitration between S-transceiver and off-chip HDLC controllers.

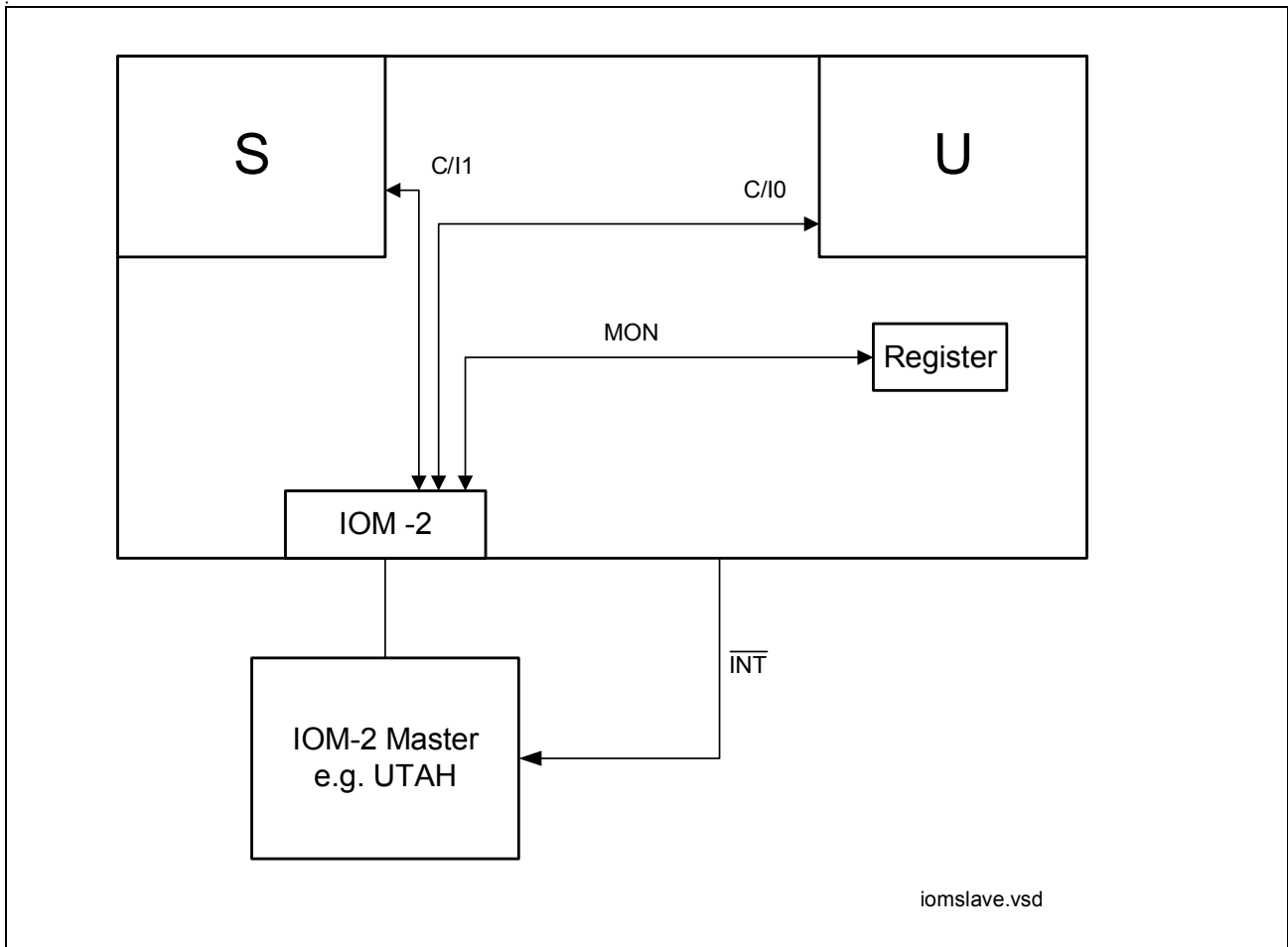

Figure 5 Control via IOM[®]-2 Interface

2 Functional Description

2.1 Microcontroller Interfaces

The T-SMINT[®]I supports either a serial or a parallel microcontroller interface. For applications where no controller is connected to the T-SMINT[®]I microcontroller interface, register programming is done via the IOM[®]-2 MONITOR channel from a master device. In such applications the T-SMINT[®]I operates in the IOM[®]-2 slave mode (refer to the corresponding chapter of the IOM[®]-2 MONITOR handler).

The interface selections are all done by pinstrapping. The possible interface selections are listed in **Table 4**. The selection pins are evaluated when the reset input $\overline{\text{RST}}$ is released. For the pin levels stated in the tables the following is defined:

'High':dynamic pin value which must be 'High' when the pin level is evaluated

V_{DD} , V_{SS} :static 'High' or 'Low' level (tied to V_{DD} , V_{SS})

Table 4 Interface Selection for the T-SMINT[®]I

PINS		Serial/Parallel Interface	PINS		Interface Type/Mode
WR (R/W)	RD (DS)		CS	ALE	
'High'	'High'	Parallel	'High'	V_{DD}	Motorola
				V_{SS}	Siemens/Intel Non-Mux
				edge	Siemens/Intel Mux
V_{SS}	V_{SS}	Serial	'High'	V_{SS}	Serial Control Interface(SCI)
			V_{SS}	V_{SS}	IOM [®] -2 MONITOR Channel (Slave Mode)

Note: For a selected interface mode which does not require all pins (e.g. address pins) the unused pins must be tied to V_{DD} .

The microcontroller interface also consists of a microcontroller clock generation at pin MCLK, an interrupt request at pin $\overline{\text{INT}}$, a reset input pin $\overline{\text{RST}}$ and a reset output pin $\overline{\text{RSTO}}$.

The interrupt request pin $\overline{\text{INT}}$ (open drain output) becomes active if the T-SMINT[®]I requests an interrupt.

2.1.1 Serial Control Interface (SCI)

The serial control interface (SCI) is compatible to the SPI interface of Motorola and to the Siemens C510 family of microcontrollers.

The SCI consists of 4 lines: SCLK, SDX, SDR and $\overline{\text{CS}}$. Data is transferred via the lines SDR and SDX at the rate given by SCLK. The falling edge of $\overline{\text{CS}}$ indicates the beginning

Functional Description

of a serial access to the registers. The T-SMINT[®] latches incoming data at the rising edge of SCLK and shifts out at the falling edge of SCLK. Each access must be terminated by a rising edge of \overline{CS} . Data is transferred in groups of 8 bits with the MSB first.

Pad mode of SDX can be selected 'open drain' or 'push-pull' by programming MODE2.PPSDX.

Figure 6 shows the timing of a one byte read/write access via the serial control interface.

Functional Description

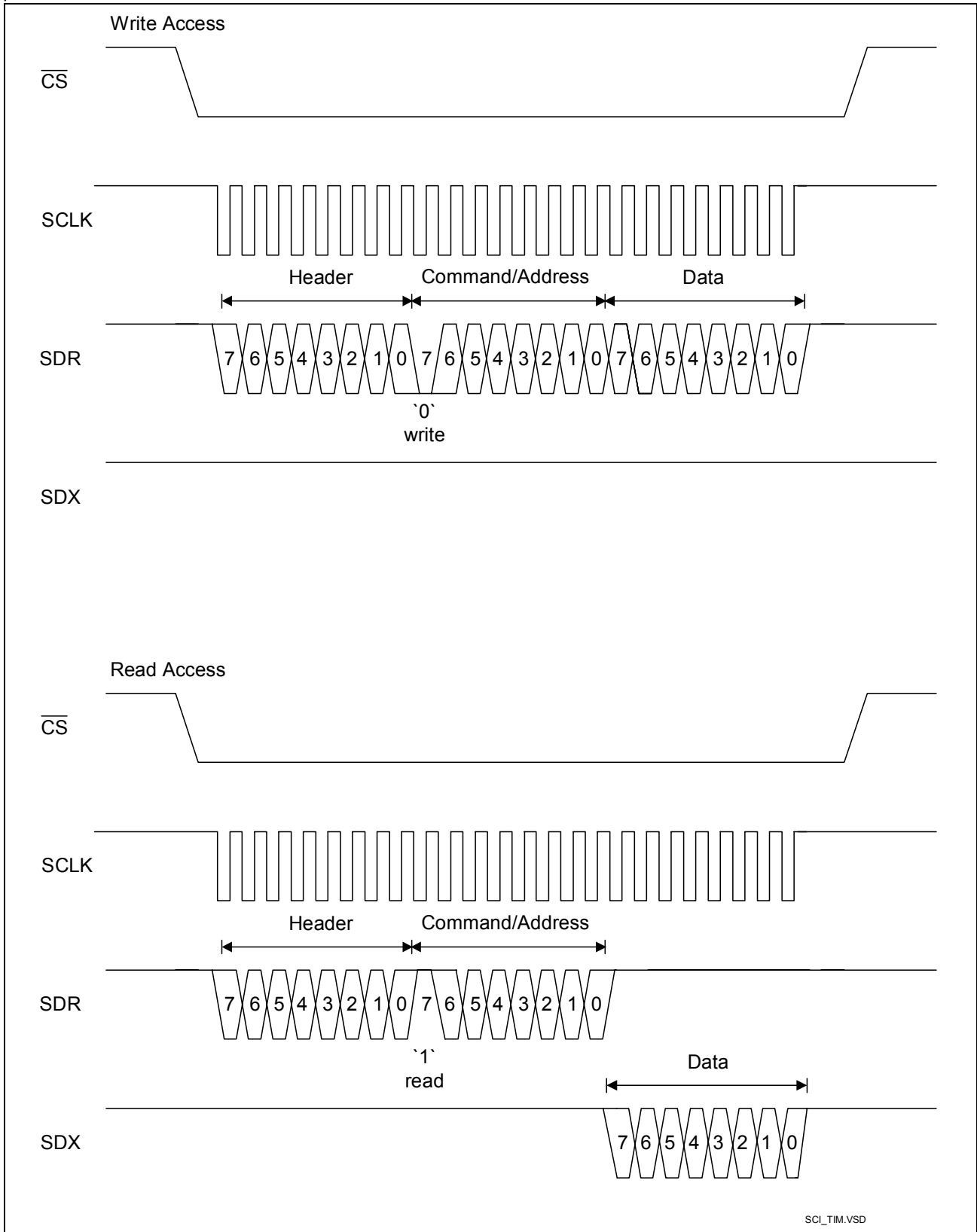

Figure 6 Serial Control Interface Timing

Functional Description

2.1.1.1 Programming Sequences

The basic structure of a read/write access to the T-SMINT[®]I registers via the serial control interface is shown in **Figure 7**.

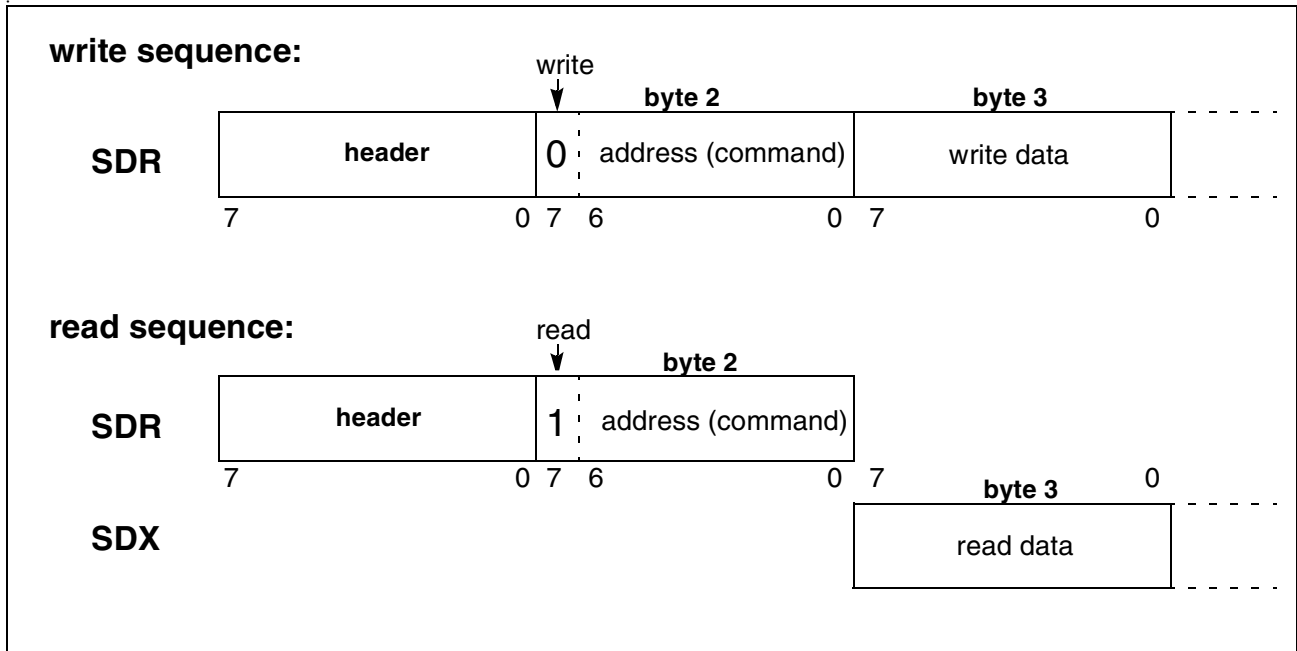

Figure 7 Serial Command Structure

A new programming sequence starts with the transfer of a header byte. The header byte specifies different programming sequences allowing a flexible and optimized access to the individual functional blocks of the T-SMINT[®]I.

The possible sequences are listed in **Table 5** and are described after that.

Table 5 Header Byte Code

Header Byte	Sequence	Sequence Type	Access to
40 _H	Adr-Data-Adr-Data	non-interleaved	Address Range 00 _H -7F _H
48 _H		interleaved	
43 _H	Adr-Data-Data-Data	Read-/Write-only	Address Range 00 _H -7F _H
41 _H		non-interleaved	
49 _H		interleaved	

Header 40_H: Non-interleaved A-D-A-D Sequences

The non-interleaved A-D-A-D sequences give direct read/write access to the address range 00_H-7F_H and can have any length. In this mode SDX and SDR can be connected

Functional Description

together allowing data transmission on one line.

Example for a read/write access with header 40_H:

SDR	header	wradr	wrdata	rdadr		rdadr		wradr	wrdata	
SDX					rddata		rddata			

Header 48_H: Interleaved A-D-A-D Sequences

The interleaved A-D-A-D sequences give direct read/write access to the address range 00_H-7F_H and can have any length. This mode allows a time optimized access to the registers by interleaving the data on SDX and SDR.

Example for a read/write access with header 48_H:

SDR	header	wradr	wrdata	rdadr	rdadr	wradr	wrdata			
SDX					rddata	rddata				

Header 43_H: Read-/Write- only A-D-D-D Sequence

Generally, it can be used for any register access to the address range 20_H-7D_H. The sequence can have any length and is terminated by the rising edge of CS.

Example for a write access with header 43_H:

SDR	header	wradr	wrdata (wradr)	wrdata (wradr)	wrdata (wradr)	wrdata (wradr)	wrdata (wradr)	wrdata (wradr)	wrdata (wradr)	
SDX										

Example for a read access with header 43_H:

SDR	header	rdadr								
SDX			rddata (rdadr)	rddata (rdadr)	rddata (rdadr)	rddata (rdadr)	rddata (rdadr)	rddata (rdadr)	rddata (rdadr)	

Header 41_H: Non-interleaved A-D-D-D Sequence

This sequence (header 41_H) allows in front of the A-D-D-D write access a non-interleaved A-D-A-D read access. Generally, it can be used for any register access to the address range 20_H-7D_H. The termination condition of the read access is the reception of the wradr. The sequence can have any length and is terminated by the rising edge of CS.

Functional Description

Example for a read/write access with header 41_H:

SDR	header	rdadr		rdadr		wradr	wrdata (wradr)	wrdata (wradr)	wrdata (wradr)	
SDX			rddata		rddata					

Header 49_H: Interleaved A-D-D-D Sequence

This sequence (header 49_H) allows in front of the A-D-D-D write access an interleaved A-D-A-D read access. Generally, it can be used for any register access to the address range 20_H-7D_H. The termination condition of the read access is the reception of the wradr. The sequence can have any length and is terminated by the rising edge of \overline{CS} .

Example for a read/write access with header 49_H:

SDR	header	rdadr	rdadr	wradr	wrdata (wradr)	wrdata (wradr)	wrdata (wradr)			
SDX			rddata	rddata						

2.1.2 Parallel Microcontroller Interface

The 8-bit parallel microcontroller interface with address decoding on chip allows an easy and fast microcontroller access.

The parallel interface of the T-SMINT[®]I provides three types of μ P busses which are selected via pin ALE. The bus operation modes with corresponding control pins are listed in [Table 6](#).

Table 6 Bus Operation Modes

	Bus Mode	Pin ALE	Control Pins
(1)	Motorola	V _{DD}	\overline{CS} , R/W, \overline{DS}
(2)	Siemens/Intel non-multiplexed	V _{SS}	\overline{CS} , \overline{WR} , \overline{RD}
(3)	Siemens/Intel multiplexed	Edge	\overline{CS} , \overline{WR} , \overline{RD} , ALE

The occurrence of an edge on ALE, either positive or negative, at any time during the operation immediately selects the interface type (3). A return to one of the other interface types is possible only if a hardware reset is issued.

Note: For a selected interface mode which does not require all pins (e.g. address pins) the unused pins must be tied to V_{DD}.

A read/write access to the T-SMINT[®]I registers can be done in **multiplexed or non-multiplexed** mode.

In non-multiplexed mode the register address must be applied to the address bus (A0-A6) for the data access via the data bus (D0-D7).

Functional Description

In multiplexed mode the address on the address bus (AD0-AD7) is latched in by ALE before a read/write access via the address/data bus is performed.

The T-SMINT[®]I provides two different ways to address the register contents which can be selected with the AMOD bit in the MODE2 register. The address mode after reset is the indirect address mode (AMOD = '0'). Reprogramming into the direct address mode (AMOD = '1') has to take place in the indirect address mode. **Figure 8** illustrates both register addressing modes.

Direct address mode (AMOD = '1'): The register address to be read or written is directly set in the way described above.

Indirect address mode (AMOD = '0'):

- non-muxed: only the LSB of the address bus (A0)
- muxed: only the LSB of the address-data bus (AD0)

gets evaluated to address a virtual ADDRESS (0_H) and a virtual DATA (1_H) register.

Every access to a target register consists of:

- a write access (muxed or non-muxed) to ADDRESS to store the target register's address, as well as
- a read access (muxed or non-muxed) from DATA to read from the target register or
- a write access (muxed or non-muxed) to DATA to write to the target register

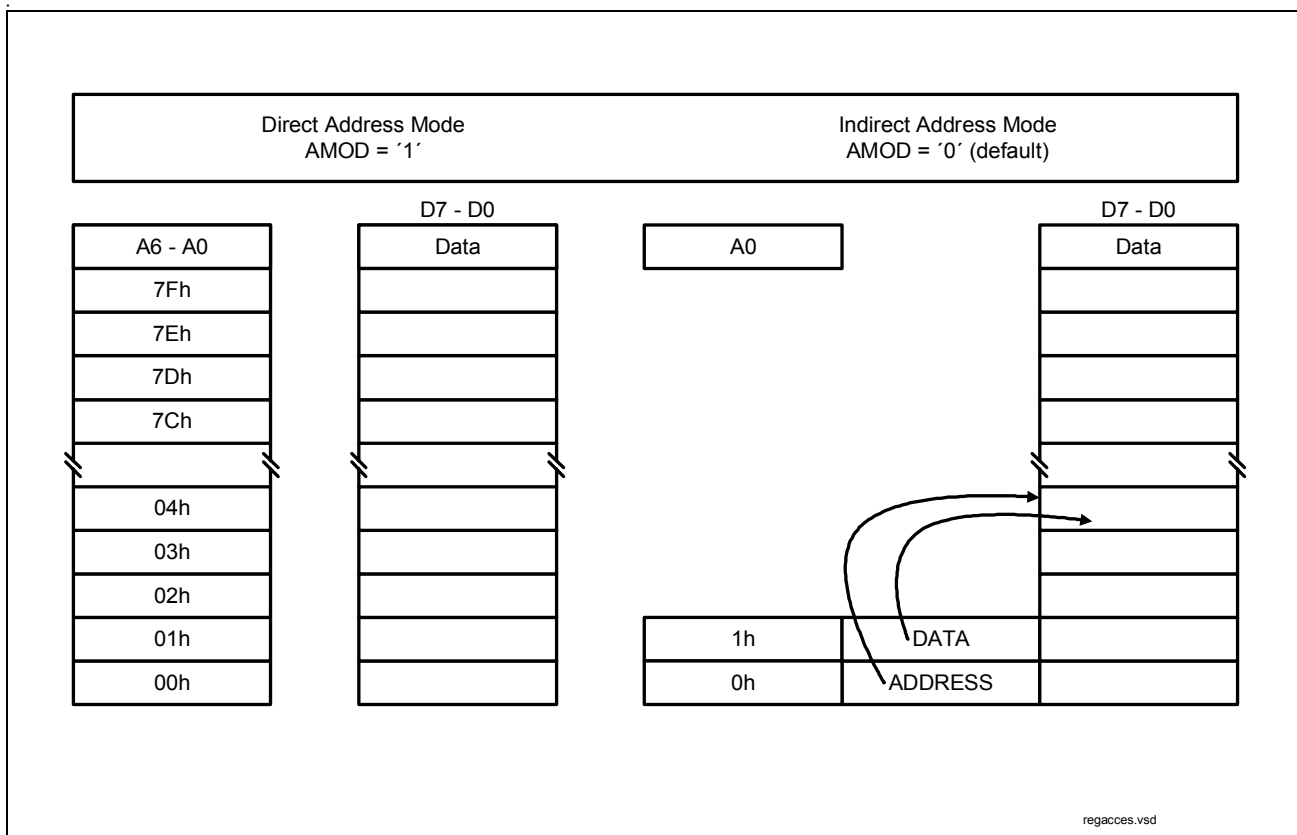

Figure 8 Direct/Indirect Register Address Mode

2.1.3 Microcontroller Clock Generation

The microcontroller clock is derived from the unregulated 15.36 MHz clock from the oscillator and provided by the pin MCLK. Five clock rates are selectable by a programmable prescaler which is controlled by the bits MODE1.MCLK and MODE1.CDS corresponding to the following table.

Table 7 MCLK Frequencies

MODE1.MCLK Bits		MCLK frequency with MODE1.CDS = '0'	MCLK frequency with MODE1.CDS = '1'
0	0	3.84 MHz	7.68 MHz
0	1	0.96 MHz	1.92 MHz
1	0	7.68 MHz	15.36 MHz
1	1	disabled	disabled

The clock rate is changed after \overline{CS} becomes inactive.

2.2 Reset Generation

Figure 9 shows the organization of the reset generation of the T-SMINT®I.

Functional Description

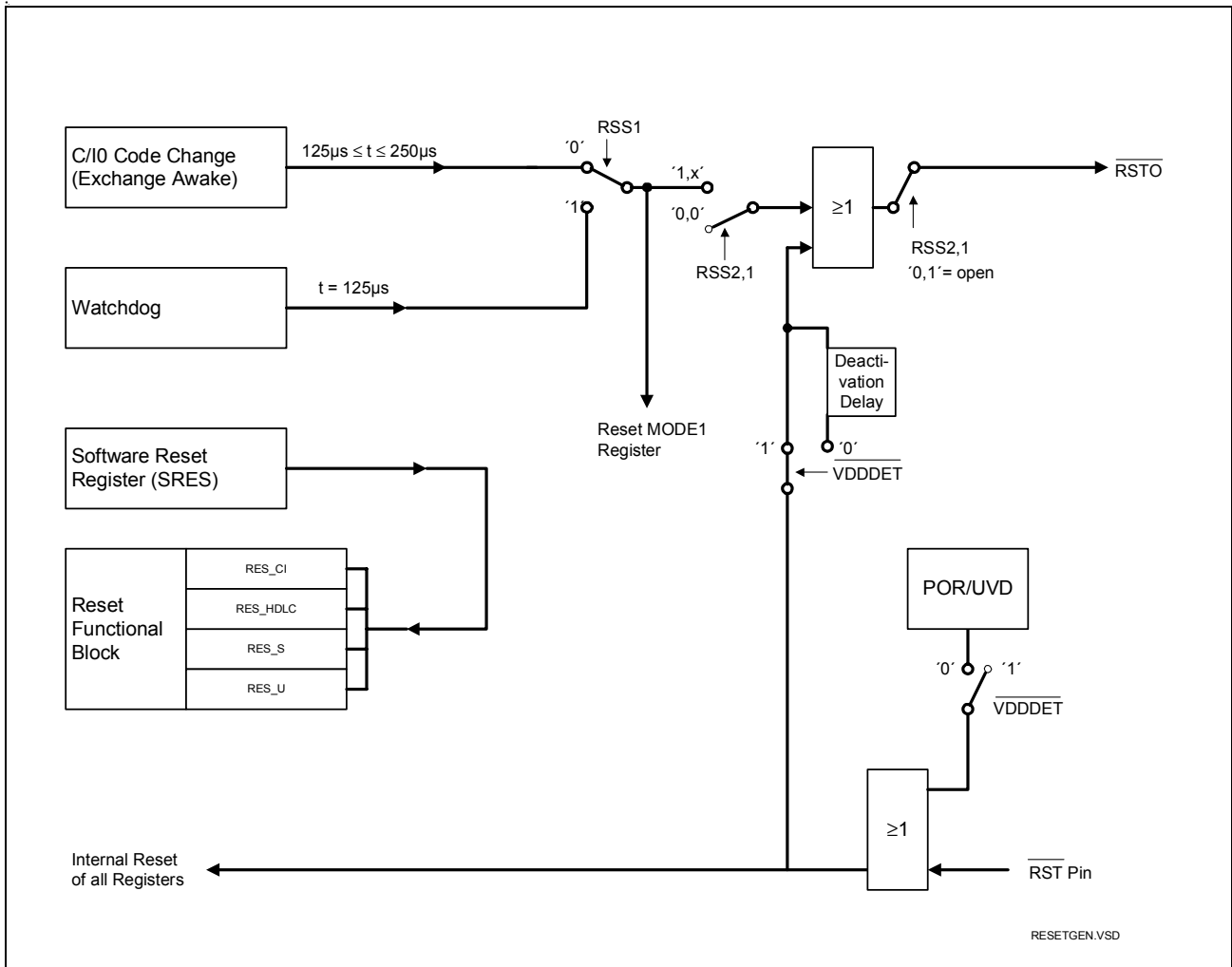

Figure 9 Reset Generation of the T-SMINT® I1)

Reset Source Selection

The internal reset sources C/I code change and Watchdog timer can be output at the low active reset pin \overline{RSTO} . These reset sources can be selected with the RSS2,1 bits in the MODE1 register according to [Table 8](#).

1) The 'OR'-gates shall illustrate in a symbolic way, that 'source A active' or 'source B active' is forwarded. The real polarity of the different sources is not considered.

Functional Description

The internal reset sources set the MODE1 register to its reset value.

Table 8 Reset Source Selection

RSS2 Bit 1	RSS1 Bit 0	C/I Code Change	Watchdog Timer	POR/UVD ¹⁾ and $\overline{\text{RST}}$
0	0	--	--	x
0	1	/RSTO disabled (= high impedance)		
1	0	x	--	x
1	1	--	x	x

¹⁾ POR/UVD can be enabled/disabled via pin $\overline{\text{VDDDET}}$

- **C/I Code Change (Exchange Awake)**

A change in the downstream C/I channel (C/I0) generates a reset pulse of $125 \mu\text{s} \leq t \leq 250 \mu\text{s}$.

- **Watchdog Timer**

After the selection of the watchdog timer (RSS = '11') an internal timer is reset and started. During every time period of 128 ms the microcontroller has to program the WTC1- and WTC2 bits in the following sequence to reset and restart the watchdog timer:

	WTC1	WTC2
1.	1	0
2.	0	1

Otherwise the timer expires and a WOV-interrupt (ISTA Register) together with a reset out pulse on pin $\overline{\text{RSTO}}$ of $125 \mu\text{s}$ is generated.

Deactivation of the watchdog timer is only possible with a hardware reset (including expiration of the watchdog timer).

As in the SCOUT-S, the watchdog timer is clocked with the IOM[®]-2 clocks and works only if the internal IOM[®]-2 clocks are active. Hence, the power consumption is minimized in state power down.

Software Reset Register (SRES)

Several main functional blocks of the T-SMINT[®]I can be reset separately by software setting the corresponding bit in the SRES register. This is equivalent to a hardware reset of the corresponding functional block. The reset state is activated as long as the bit is set to '1'.

Functional Description

External Reset Input

At the $\overline{\text{RST}}$ input an external reset can be applied forcing the T-SMINT[®]I in the reset state. This external reset signal is additionally fed to the $\overline{\text{RSTO}}$ output.

After release of an external reset, the μC has to wait for min. $t_{\mu\text{C}}$ before it starts read or write access to the T-SMINT[®]I (see [Table 37](#)).

Reset Output

If $\overline{\text{VDDDET}}$ is active, then the deactivation of a reset output on $\overline{\text{RSTO}}$ is delayed by t_{DEACT} (see [Table 38](#)).

Reset Generation

The T-SMINT[®]I has an on-chip reset generator based on a Power-On Reset (POR) and Under Voltage Detection (UVD) circuit (see [Table 38](#)). The POR/UVD requires no external components.

The POR/UVD circuit can be disabled via pin $\overline{\text{VDDDET}}$.

The requirements on V_{DD} ramp-up during power-on reset are described in [Chapter 5.6.5](#).

Clocks and Data Lines During Reset

During reset the data clock (DCL), the bit clock (BCL), the microcontroller clock¹⁾ (MCLK) and the frame synchronization (FSC) keep running.

During reset DD and DU are high; with the exception of:

- The output C/I code from the U-Transceiver on DD IOM[®]-2 channel 0 is 'DR' = 0000 (Value after reset of register UCIR = '00_H')
- The output C/I code from the S-Transceiver on DU IOM[®]-2 channel 1 is 'TIM' = 0000.

¹⁾ during a Power-On/UVD Reset, the microcontroller clock MCLK is not running, but starts running as soon as timer t_{DEAC} is started.

2.3 IOM[®]-2 Interface

The T-SMINT[®]I supports the IOM[®]-2 interface in terminal mode (DCL=1.536 MHz) according to the IOM[®]-2 Reference Guide [12].

2.3.1 IOM[®]-2 Functional Description

The IOM[®]-2 interface consists of four lines: FSC, DCL, DD, DU and optionally BCL. The rising edge of FSC indicates the start of an IOM[®]-2 frame. The DCL and the BCL clock signals synchronize the data transfer on both data lines DU and DD. The DCL is twice the bit rate, the BCL rate is equal to the bit rate. The bits are shifted out with the rising edge of the first DCL clock cycle and sampled at the falling edge of the second clock cycle. With BCL the bits are shifted out with the rising edge and sampled with the falling edge of the single clock cycle.

The IOM[®]-2 interface can be enabled/disabled with the DIS_IOM bit in the IOM_CR register. The FSC signal is an 8 kHz frame sync signal. The number of PCM timeslots on the receive and transmit lines is determined by the frequency of the DCL clock (or BCL), with the 1.536 MHz (BCL=768 kHz) clock 3 channels consisting of 4 timeslots each are available.

IOM[®]-2 Frame Structure of the T-SMINT[®]I

The frame structure on the IOM[®]-2 data ports (DU,DD) of the T-SMINT[®]I with a DCL clock of 1.536 MHz (or BCL=768 kHz) and if TIC bus is not disabled (IOM_CR.TIC_DIS) is shown in [Figure 10](#).

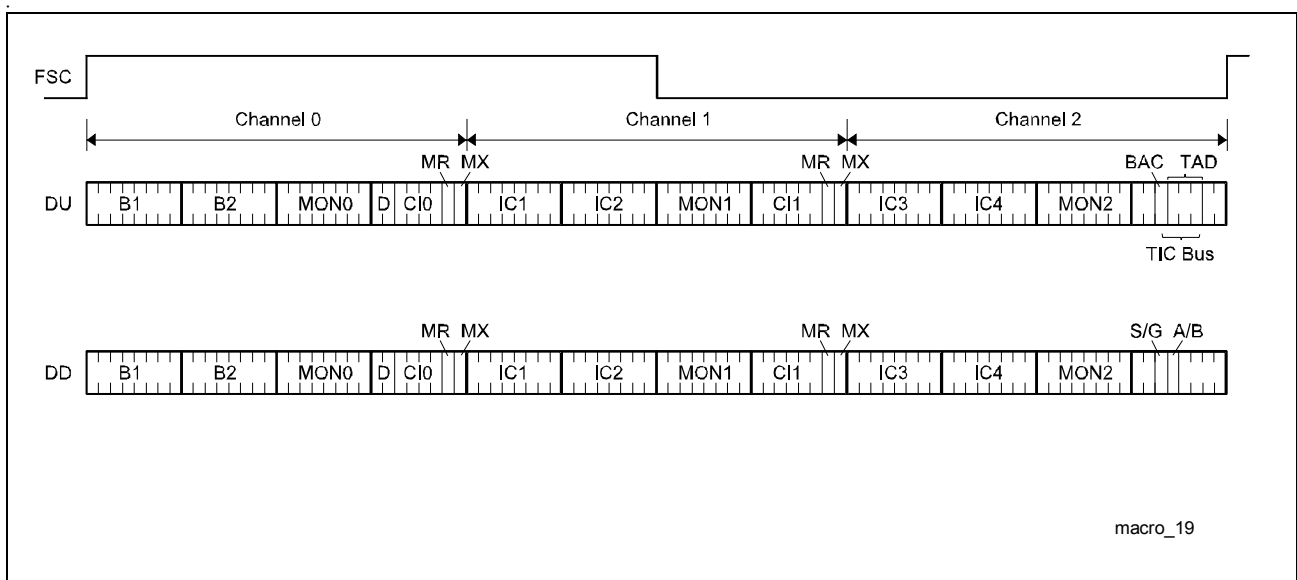

Figure 10 IOM[®]-2 Frame Structure of the T-SMINT[®]I

Functional Description

The frame is composed of three channels:

- Channel 0 contains 144-kbit/s of user and signaling data (2B + D), a MONITOR programming channel (MON0) and a command/indication channel (CI0) for control and programming of e.g. the U-transceiver.
- Channel 1 contains two 64-kbit/s intercommunication channels (IC), a MONITOR programming channel (MON1) and a command/indication channel (CI1) for control and programming of e.g. the S-transceiver.
- Channel 2 is used for D-channel access mechanism (TIC-bus, S/G bit). Additionally, channel 2 supports further IC and MON channels.

2.3.2 IOM[®]-2 Handler

The IOM[®]-2 handler offers a great flexibility for handling the data transfer between the different functional units of the T-SMINT[®]I and voice/data devices connected to the IOM[®]-2 interface. Additionally it provides a microcontroller access to all time slots of the IOM[®]-2 interface via the four controller data access registers (CDA).

The PCM data of the functional units

- S-transceiver (S) and the
- Controller data access (CDA)

can be configured by programming the time slot and data port selection registers (TSDP). With the TSS bits (Time Slot Selection) the PCM data of the functional units can be assigned to each of the 12 PCM time slots of the IOM[®]-2 frame. With the DPS bit (Data Port Selection) the output of each functional unit is assigned to DU or DD respectively. The input is assigned vice versa. With the control registers (CR) the access to the data of the functional units can be controlled by setting the corresponding control bits (EN, SWAP).

The IOM[®]-2 handler also provides access to the

- U and S transceiver
- MONITOR channel
- C/I channels (CI0,CI1)
- TIC bus (TIC)

The access to these channels is controlled by the registers S_CR, CI_CR and MON_CR. The IOM[®]-2 interface with the two Serial Data Strokes (SDS1,2) is controlled by the control registers IOM_CR, SDS1_CR and SDS2_CR.

The following **Figure 11** shows the architecture of the IOM[®]-2 handler.

Functional Description

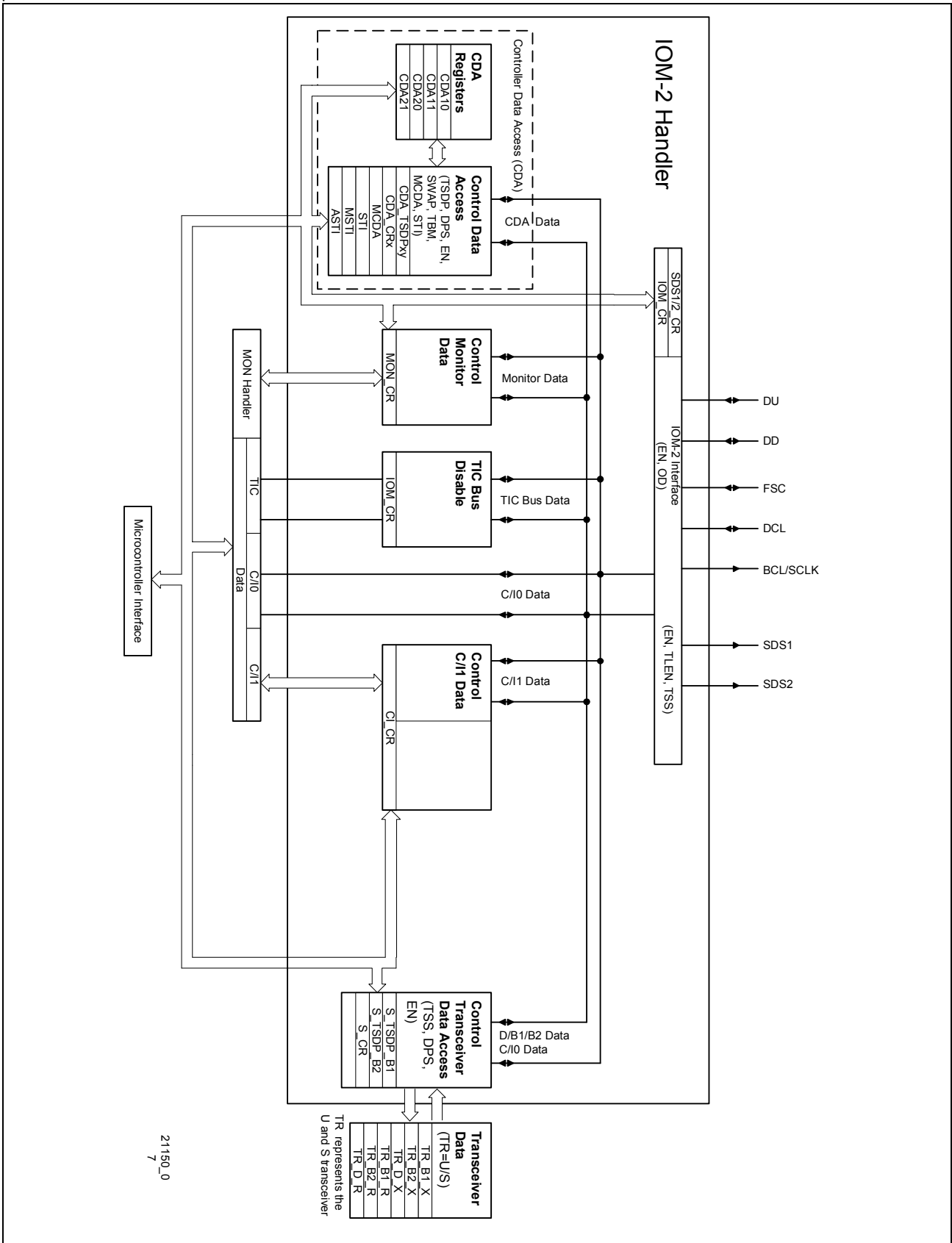

Figure 11 Architecture of the IOM[®]-2 Handler

2.3.2.1 Controller Data Access (CDA)

The four controller data access registers (CDA10, CDA11, CDA20, CDA21) provide microcontroller access to the 12 IOM[®]-2 time slots and more:

- looping of up to four independent PCM channels from DU to DD or vice versa over the four CDA registers
- shifting or switching of two independent PCM channels to another two independent PCM channels on both data ports (DU, DD). Between reading and writing the data can be manipulated (processed with an algorithm) by the microcontroller. If this is not the case a switching function is performed.
- monitoring of up to four time slots on the IOM[®]-2 interface simultaneously
- microcontroller read and write access to each PCM channel

The access principle, which is identical for the two channel register pairs CDA10/11 and CDA20/21, is illustrated in [Figure 12](#). The index variables x,y used in the following description can be 1 or 2 for x, and 0 or 1 for y. The prefix 'CDA_' from the register names has been omitted for simplification.

To each of the four CDAXy data registers a TSDPxy register is assigned by which the time slot and the data port can be determined. With the TSS (Time Slot Selection) bits a time slot from 0...11 can be selected. With the DPS (Data Port Selection) bit the output of the CDAXy register can be assigned to DU or DD respectively. The time slot and data port for the output of CDAXy is always defined by its own TSDPxy register. The input of CDAXy depends on the SWAP bit in the control registers CRx.

If the SWAP bit = '0' (swap is disabled) the time slot and data port for the input and output of the CDAXy register is defined by its own TSDPxy register.

If the SWAP bit = '1' (swap is enabled) the input port and time slot of the CDAX0 is defined by the TSDP register of CDAX1 and the input port and time slot of CDAX1 is defined by the TSDP register of CDAX0. The input definition for time slot and data port CDAX0 are thus swapped to CDAX1 and for CDAX1 swapped to CDAX0. The output timeslots are not affected by SWAP.

The input and output of every CDAXy register can be enabled or disabled by setting the corresponding EN (-able) bit in the control register CDAX_CR. If the input of a register is disabled the output value in the register is retained.

Usually one input and one output of a functional unit (transceiver, CDA register) is programmed to a timeslot on IOM[®]-2 (e.g. for B-channel transmission in upstream direction the S-transceiver writes data onto IOM[®]-2 and the U-transceiver reads data from IOM[®]-2). For monitoring data in such cases a CDA register is programmed as described below under "Monitoring Data". Besides that none of the IOM[®]-2 timeslots must be assigned more than one input and output of any functional unit.

Functional Description

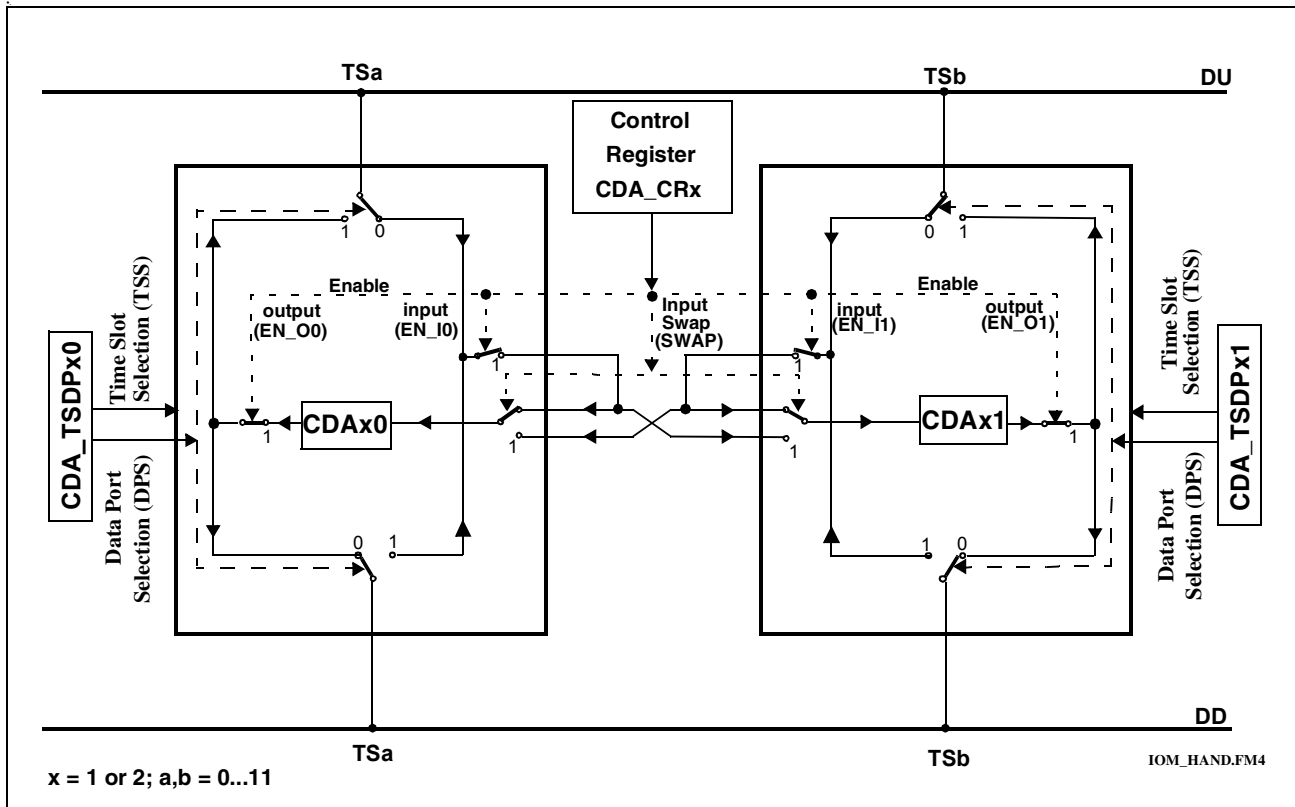

Figure 12 Data Access via CDAX0 and CDAX1 register pairs

Looping and Shifting Data

Figure 13 gives examples for typical configurations with the above explained control and configuration possibilities with the bits TSS, DPS, EN and SWAP in the registers TSDPx_y or CDAX_x_CR:

- a) looping IOM[®]-2 time slot data from DU to DD or vice versa (SWAP = '0')
- b) shifting data from TSa to TSb and TS_c to TS_d in both transmission directions (SWAP = '1')
- c) switching data from TSa to TSb and looping from DU to DD or switching TS_c to TS_d and looping from DD to DU .

TSa is programmed in TSDP10, TSb in TSDP11, TS_c in TSDP20 and TS_d in TSDP21.

Functional Description

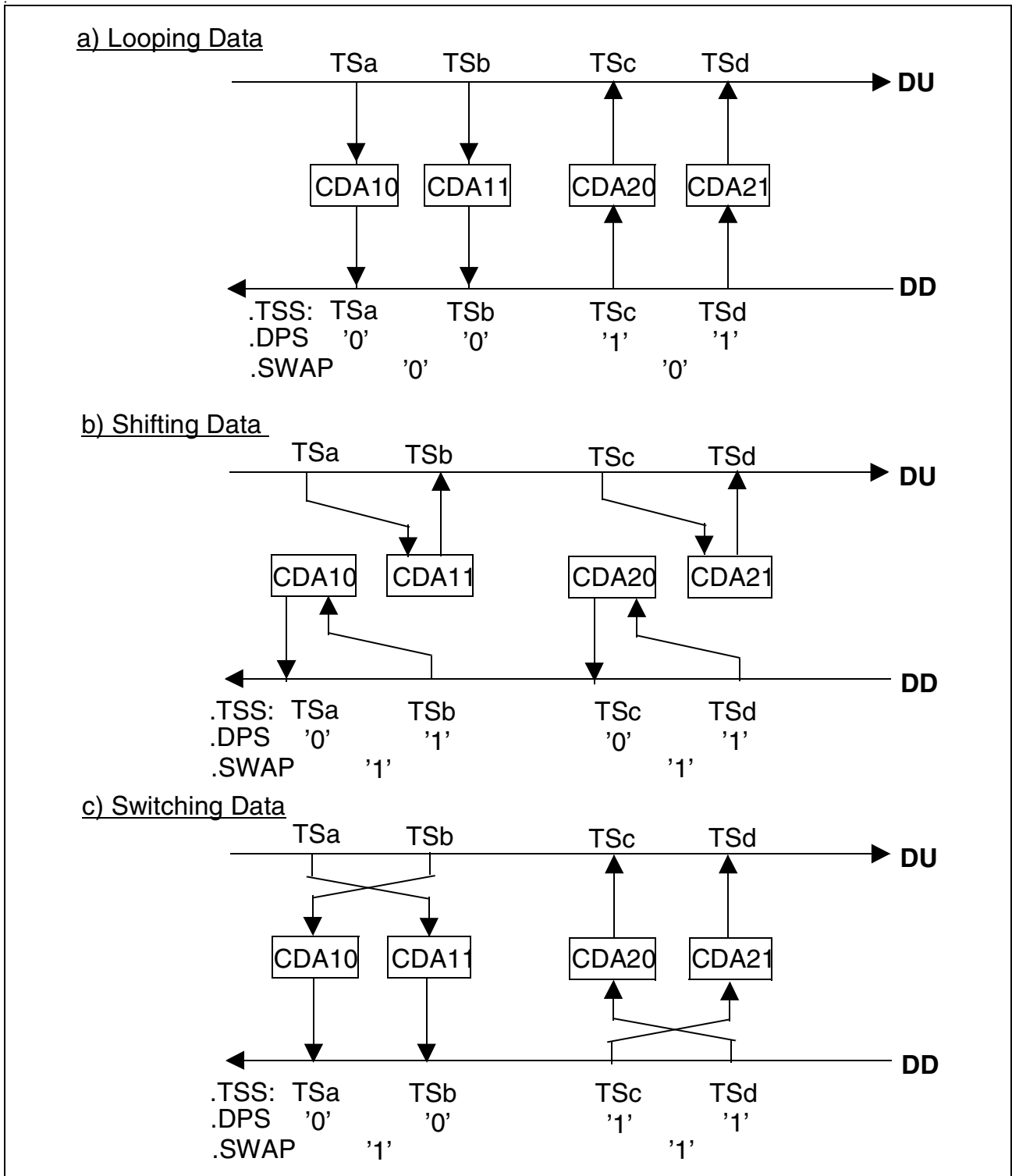

Figure 13 Examples for Data Access via CDAxy Registers

- a) Looping Data
- b) Shifting (Switching) Data
- c) Switching and Looping Data

Functional Description

Figure 14 shows the timing of looping TSa from DU to DD via CDAXy register. TSa is read in the CDAXy register from DU and is written one frame later on DD.

Figure 15 shows the timing of shifting data from TSa to TSb on DU(DD). In **Figure 15a**) shifting is done in one frame because TSa and TSb didn't succeed directly one another ($a = 0...9$ and $b \geq a+2$). In **Figure 15b**) shifting is done from one frame to the following frame. This is the case when the time slots succeed one other ($b = a+1$) or b is smaller than a ($b < a$).

At looping and shifting the data can be accessed by the controller between the synchronous transfer interrupt (STI) and the status overflow interrupt (STOV). STI and STOV are explained in the section 'Synchronous Transfer'. If there is no controller intervention the looping and shifting is done autonomously.

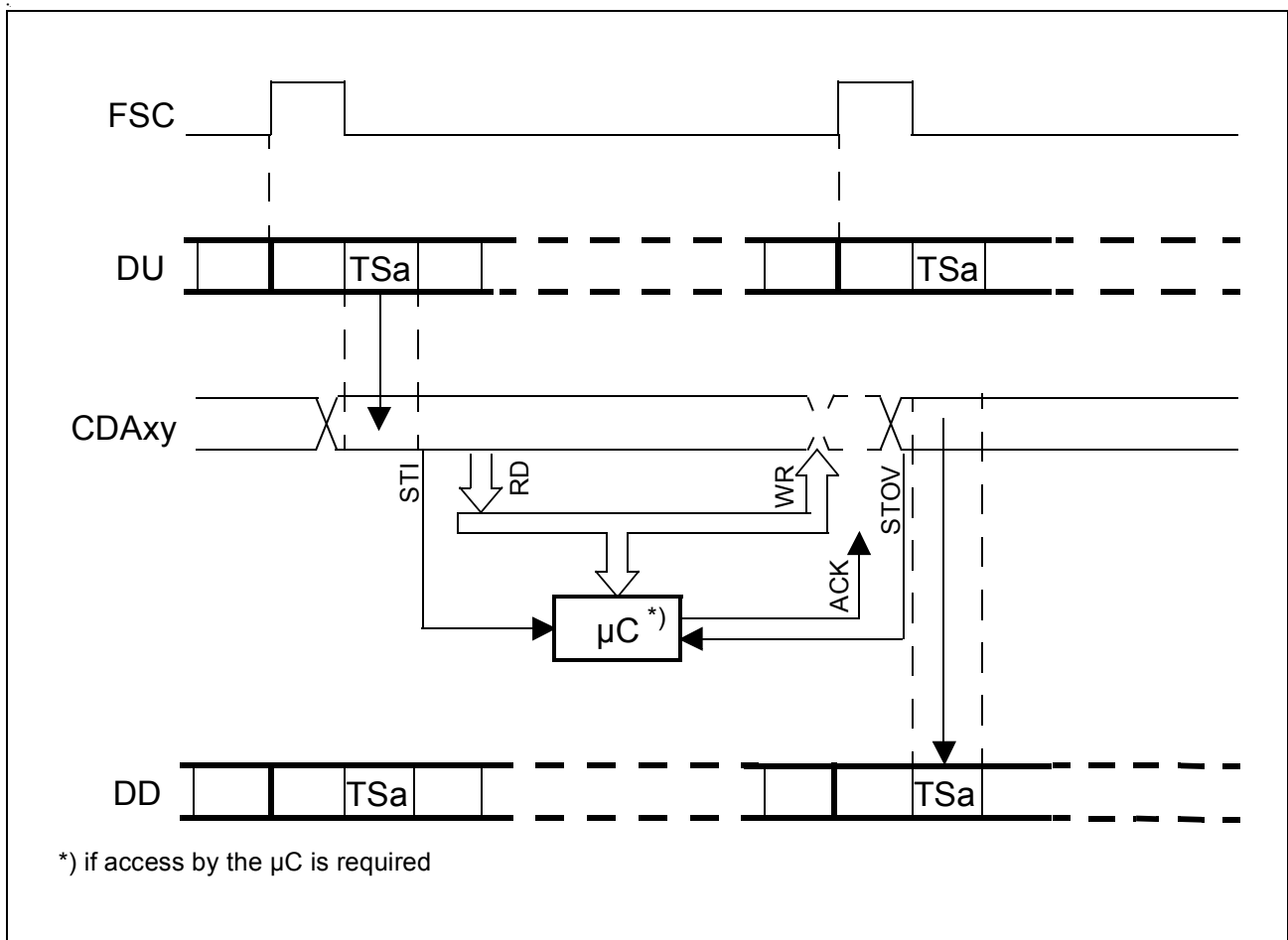

Figure 14 Data Access when Looping TSa from DU to DD

Functional Description

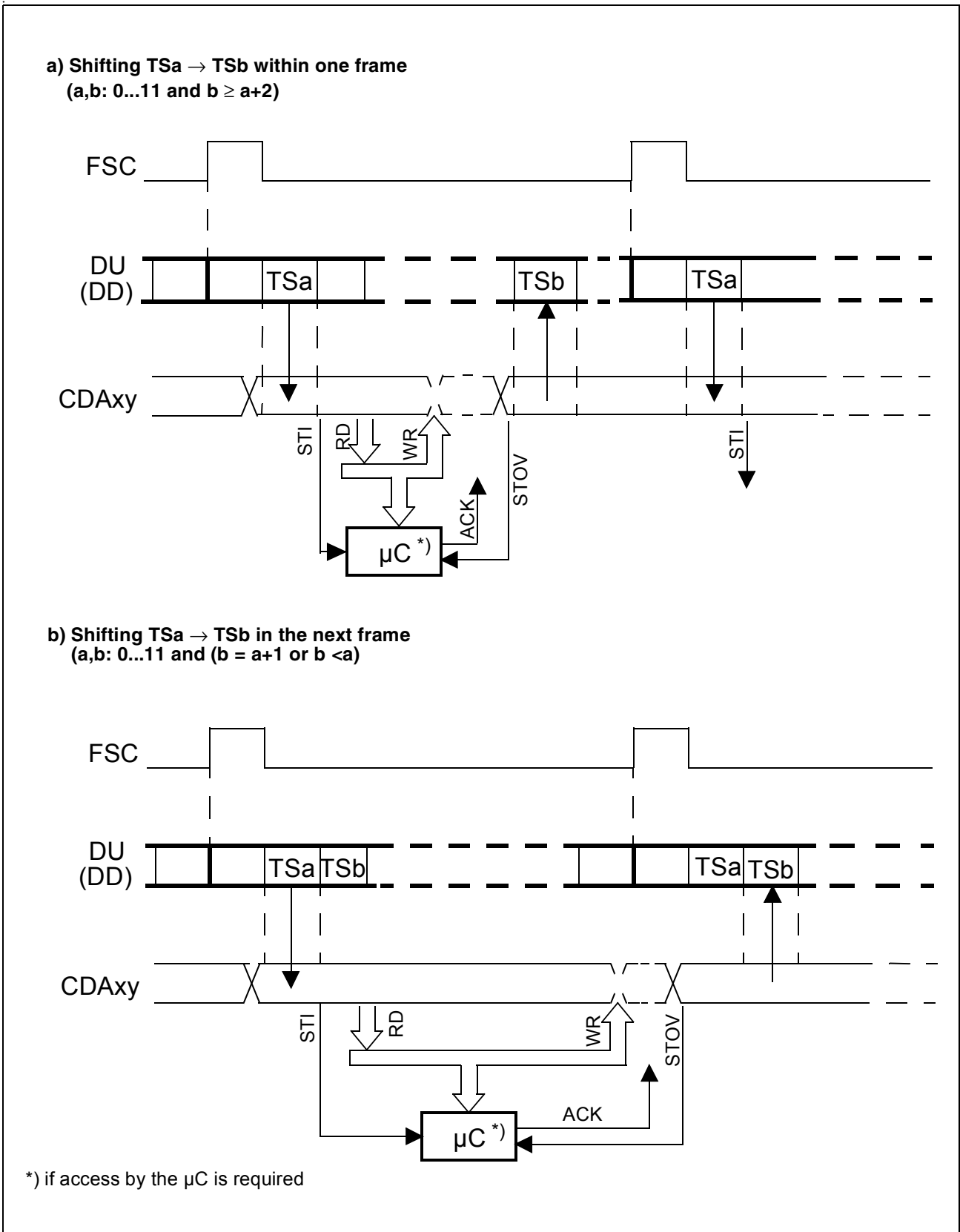

Figure 15 Data Access when Shifting TSa to TSb on DU (DD)

Monitoring Data

Figure 16 gives an example for monitoring of two IOM[®]-2 time slots each on DU or DD simultaneously. For monitoring on DU and/or DD the channel registers with even numbers (CDA10, CDA20) are assigned to time slots with even numbers TS(2n) and the channel registers with odd numbers (CDA11, CDA21) are assigned to time slots with odd numbers TS(2n+1). The user has to take care of this restriction by programming the appropriate time slots.

This mode is only valid if two blocks (e.g. both transceivers) are programmed to these timeslots and communicating via IOM[®]-2.

However, if only one block is programmed to this timeslot the timeslots for CDAX0 and CDAX1 can be programmed completely independently.

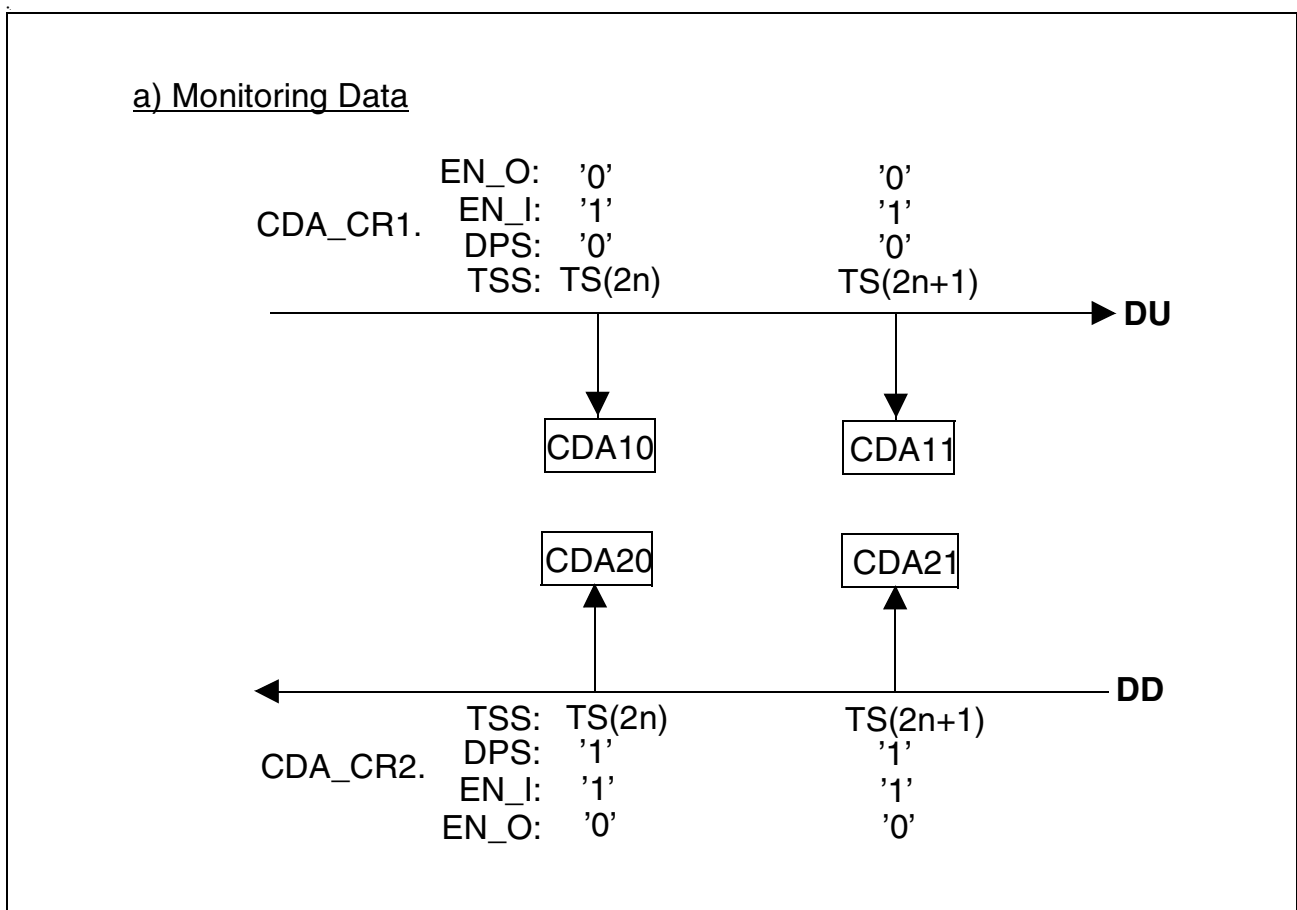

Figure 16 Example for Monitoring Data

Monitoring TIC Bus

Monitoring the TIC bus (TS11) is handled as a special case. The TIC bus can be monitored with the registers CDAX0 by setting the EN_TBM (Enable TIC Bus Monitoring) bit in the control registers CRx. The TSDPx0 must be set to 08_h for monitoring from DU

Functional Description

or 88_h for monitoring from DD. By this it is possible to monitor the TIC bus (TS11) and the odd numbered D-channel (TS3) simultaneously on DU and DD.

Synchronous Transfer

While looping, shifting and switching the data can be accessed by the controller between the synchronous transfer interrupt (STI) and the synchronous transfer overflow interrupt (STOV).

The microcontroller access to each of the CDA_{xy} registers can be synchronized by means of four programmable synchronous transfer interrupts (STI_{xy})¹⁾ and synchronous transfer overflow interrupts (STOV_{xy})²⁾ in the STI register.

Depending on the DPS bit in the corresponding TSDP_{xy} register the STI_{xy} is generated two (for DPS='0') or one (for DPS='1') BCL clock after the selected time slot (CDA_TSDP_{xy}.TSS). One BCL clock is equivalent to two DCL clocks.

In the following description the index xy_0 and xy_1 are used to refer to two different interrupt pairs (STI/STOV) out of the four CDA interrupt pairs (STI10/STOV10, STI11/STOV11, STI20/STOV20, STI21/STOV21).

A STOV_{xy₀} is related to its STI_{xy₀} and is only generated if STI_{xy₀} is enabled and not acknowledged. However, if STI_{xy₀} is masked, the STOV_{xy₀} is generated for any other STI_{xy₁} which is enabled and not acknowledged.

Table 9 gives some examples for that. It is assumed that a STOV interrupt is only generated because a STI interrupt was not acknowledged before.

In example 1 only the STI_{xy₀} is enabled and thus STI_{xy₀} is only generated. If no STI is enabled, no interrupt will be generated even if STOV is enabled (example 2).

In example 3 STI_{xy₀} is enabled and generated and the corresponding STOV_{xy₀} is disabled. STI_{xy₁} is disabled but its STOV_{xy₁} is enabled, and therefore STOV_{xy₁} is generated due to STI_{xy₀}. In example 4 additionally the corresponding STOV_{xy₀} is enabled, so STOV_{xy₀} and STOV_{xy₁} are both generated due to STI_{xy₀}.

In example 5 additionally the STI_{xy₁} is enabled with the result that STOV_{xy₀} is only generated due to STI_{xy₀} and STOV_{xy₁} is only generated due to STI_{xy₁}.

Compared to the previous example STOV_{xy₀} is disabled in example 6, so STOV_{xy₀} is not generated and STOV_{xy₁} is only generated for STI_{xy₁} but not for STI_{xy₀}.

¹⁾ In order to enable the STI interrupts the input of the corresponding CDA register has to be enabled. This is also valid if only a synchronous write access is wanted. The enabling of the output alone does not effect an STI interrupt.

²⁾ In order to enable the STOV interrupts the output of the corresponding CDA register has to be enabled. This is also valid if only a synchronous read access is wanted. The enabling of the input alone does not effect an interrupt.

Functional Description

Table 9 Examples for Synchronous Transfer Interrupts

Enabled Interrupts (Register MSTI)		Generated Interrupts (Register STI)		
STI	STOV	STI	STOV	
xy ₀	-	xy ₀	-	Example 1
-	xy ₀	-	-	Example 2
xy ₀	xy ₁	xy ₀	xy ₁	Example 3
xy ₀	xy ₀ ; xy ₁	xy ₀	xy ₀ ; xy ₁	Example 4
xy ₀ ; xy ₁	xy ₀ ; xy ₁	xy ₀ xy ₁	xy ₀ xy ₁	Example 5
xy ₀ ; xy ₁	xy ₁	xy ₀ xy ₁	- xy ₁	Example 6
xy ₀ ; xy ₁	xy ₀ ; xy ₁ ; xy ₂	xy ₀ xy ₁	xy ₀ ; xy ₂ xy ₁ ; xy ₂	Example 7

Compared to example 5 in example 7 a third STOV_{xy₂} is enabled and thus STOV_{xy₂} is generated additionally for both STI_{xy₀} and STI_{xy₁}.

A STOV interrupt is not generated if all stimulating STI interrupts are acknowledged.

A STI_{xy} must be acknowledged by setting the ACK_{xy} bit in the ASTI register two BCL clock (for DPS='0') or one BCL clocks (for DPS='1') before the time slot which is selected for the appropriate STI_{xy}. The interrupt structure of the synchronous transfer is shown in [Figure 17](#).

Functional Description

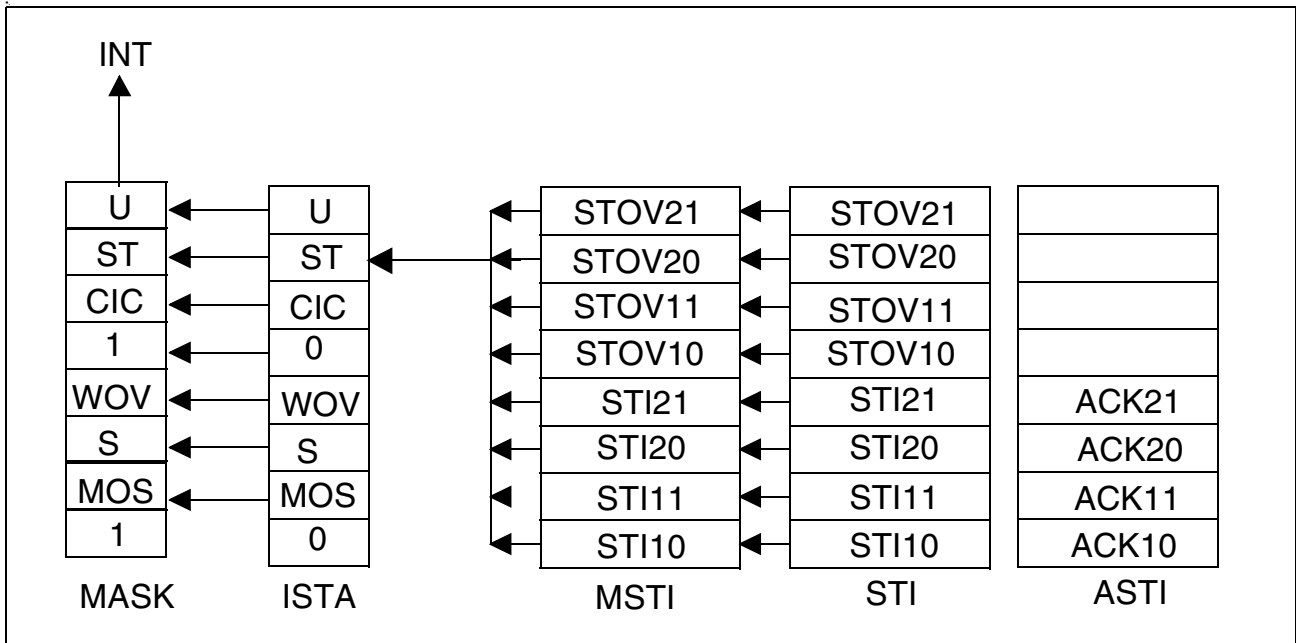

Figure 17 Interrupt Structure of the Synchronous Data Transfer

Figure 18 shows some examples based on the timeslot structure. Figure a) shows at which point in time a STI and STOV interrupt is generated for a specific timeslot. Figure b) is identical to example 3 above, figure c) corresponds to example 5 and figure d) shows example 4.

Functional Description

↓ : STI interrupt generated

⟩ : STOV interrupt generated for a not acknowledged STI interrupt

a) Interrupts for data access to time slot 0 (B1 after reset), MSTI.STI10 and MSTI.STOV10 enabled

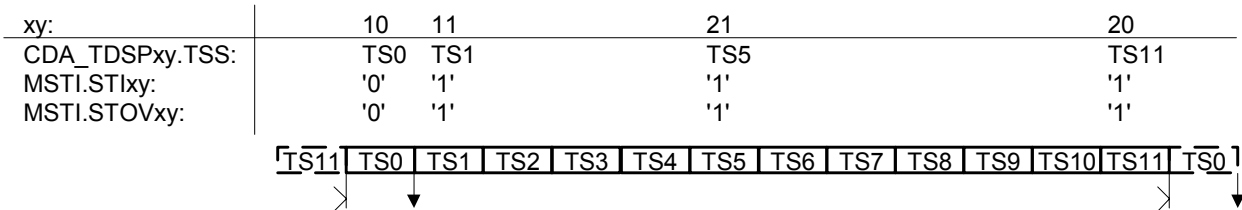

b) Interrupts for data access to time slot 0 (B1 after reset), STOV interrupt used as flag for "last possible CDA access"; MSTI.STI10 and MSTI.STOV20 enabled

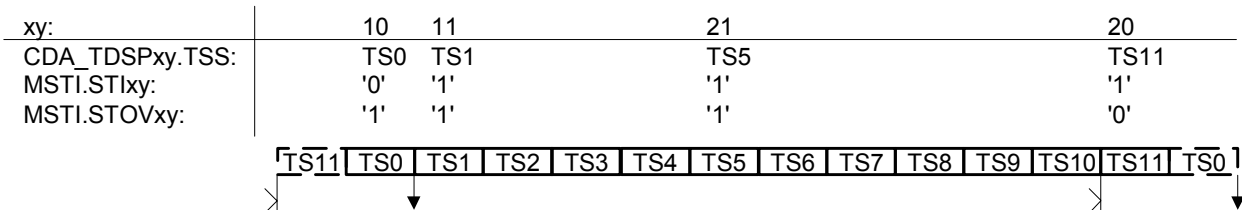

c) Interrupts for data access to time slot 0 and 1 (B1 and B2 after reset), MSTI.STI10, MSTI.STOV10, MSTI.STI11 and MSTI.STOV11 enabled

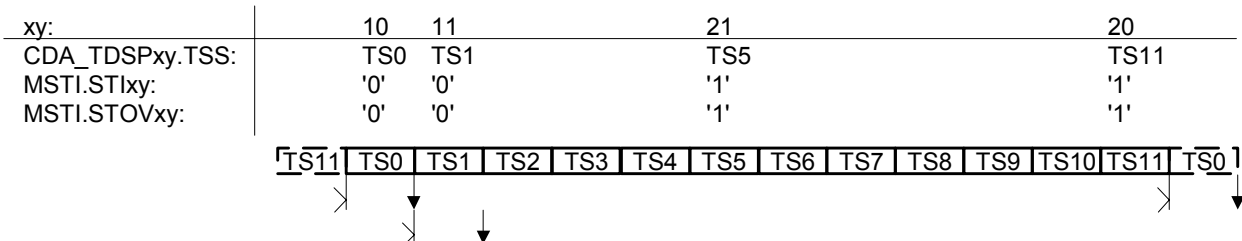

d) Interrupts for data access to time slot 0 (B1 after reset), STOV20 interrupt used as flag for "last possible CDA access", STOV10 interrupt used as flag for "CDA access failed"; MSTI.STI10, MSTI.STOV10 and MSTI.STOV20 enabled

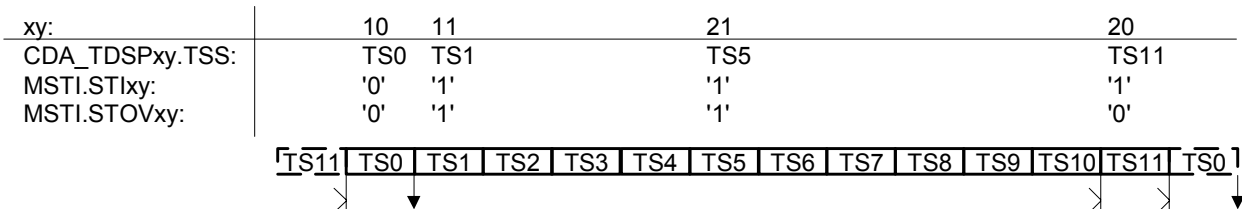

sti_stov.vsd

Figure 18 Examples for the Synchronous Transfer Interrupt Control with one STIxy enabled

2.3.2.2 Serial Data Strobe Signal

For time slot oriented standard devices at the IOM[®]-2 interface, the T-SMINT[®]I provides two independent data strobe signals SDS1 and SDS2.

The two strobe signals can be generated with every 8-kHz-frame and are controlled by the registers SDS1/2_CR. By programming the TSS bits and three enable bits (ENS_TSS, ENS_TSS+1, ENS_TSS+3) a data strobe can be generated for the IOM[®]-2 time slots TS, TS+1 and TS+3 (bit7,6) and the combinations of them.

The data strobes for TS and TS+1 are always 8 bits long (bit7 to bit0) whereas the data strobe for TS+3 is always 2 bits long (bit7, bit6).

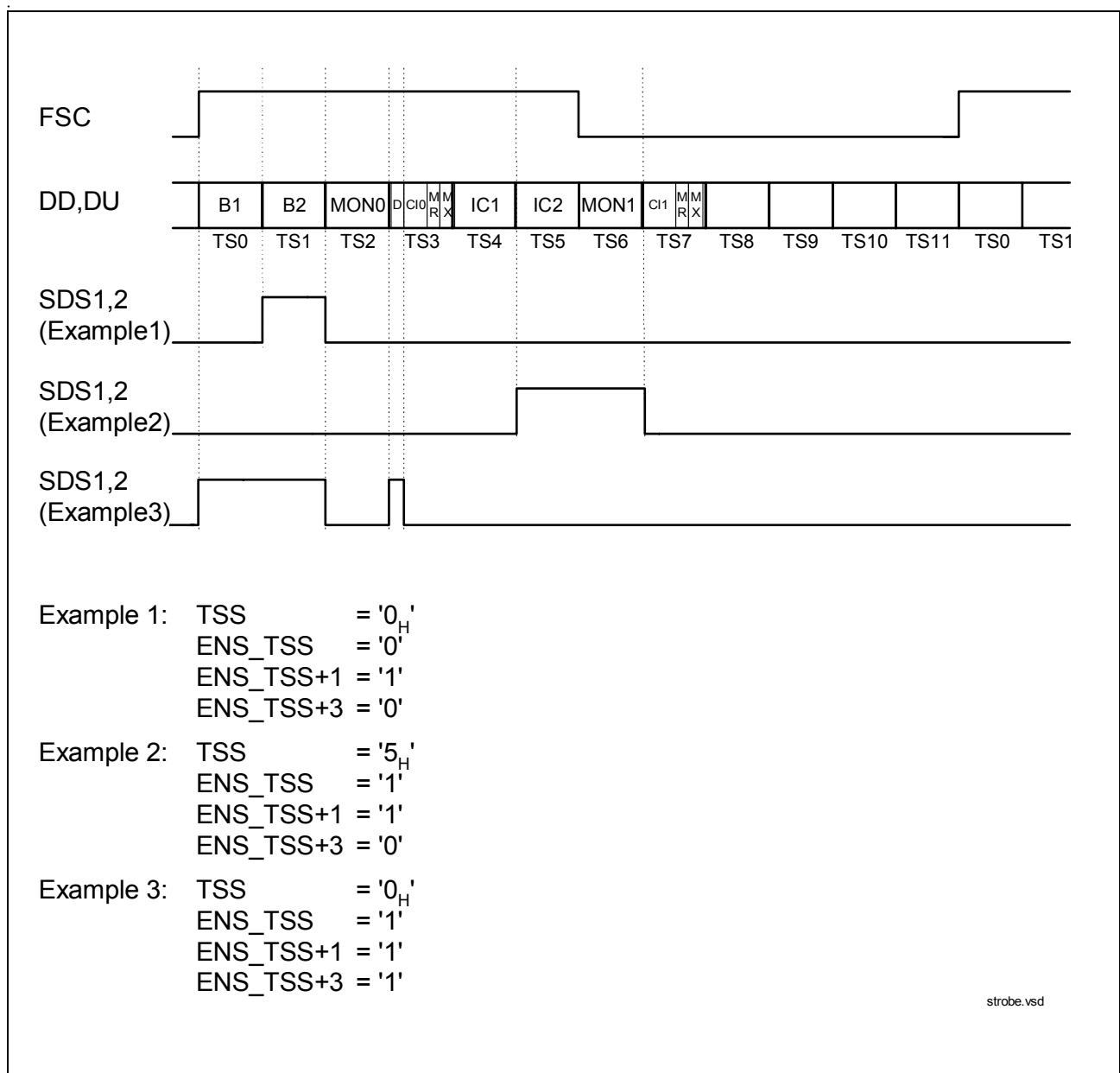

Figure 19 Data Strobe Signal Generation

Functional Description

Figure 19 shows three examples for the generation of a strobe signal. In example 1 the SDS is active during channel B2 on IOM[®]-2, whereas in the second example during IC2 and MON1. The third example shows a strobe signal for 2B+D channels which is used e.g. at an IDSL (144 kbit/s) transmission.

2.3.3 IOM[®]-2 Monitor Channel

The IOM[®]-2 MONITOR channel is utilized for information exchange between the T-SMINT[®]I and other devices in the MONITOR channel.

The MONITOR channel data can be controlled by the bits in the MONITOR control register (MON_CR). For the transmission of the MONITOR data one of the 3 IOM[®]-2 channels can be selected by setting the MONITOR channel selection bits (MCS) in the MONITOR control register (MON_CR).

The DPS bit in the same register selects between an output on DU or DD respectively and with EN_MON the MONITOR data can be enabled/disabled. The default value is MONITOR channel 0 (MON0) enabled and transmission on DD.

The MONITOR channel of the T-SMINT[®]I can be used in the following applications (refer also to and):

- As a **master device** the T-SMINT[®]I can program and control other devices (e.g. PSB 2161) attached to the IOM[®]-2, which therefore, do not need a microcontroller interface.
- As a **slave device** the T-SMINT[®]I is programmed and controlled from a master device on IOM[®]-2 (e.g. UTAH). This is used in applications where no microcontroller is connected directly to the T-SMINT[®]I.

The MONITOR channel operates according to the IOM[®]-2 Reference Guide [12].

Note: In contrast to the NTC-T, the T-SMINT[®]I does neither issue nor react on Monitor commands (MON0,1,2,8). Instead, the T-SMINT[®]I operated in IOM[®]-2 slave mode must be programmed via new MONITOR channel concept (see [Chapter 2.3.3.4](#)), which provides full register access. The Monitor time out procedure is available. Reporting of the T-SMINT[®]I is performed via interrupts.

2.3.3.1 Handshake Procedure

The MONITOR channel operates on an asynchronous basis. While data transfers on the bus take place synchronized to frame sync, the flow of data is controlled by a handshake procedure using the MONITOR Channel Receive (MR) and MONITOR Channel Transmit (MX) bits. Data is placed onto the MONITOR channel and the MX bit is activated. This data will be transmitted once per 8-kHz frame until the transfer is acknowledged via the MR bit.

Functional Description

The MONITOR channel protocol is described In the following section and **Figure 22** shall illustrate this. The relevant control and status bits for transmission and reception are listed in **Table 10** and **Table 11**.

Table 10 Transmit Direction

Control/ Status Bit	Register	Bit	Function
Control	MOCR	MXC	MX Bit Control
		MIE	Transmit Interrupt (MDA, MAB, MER) Enable
Status	MOSR	MDA	Data Acknowledged
		MAB	Data Abort
	MSTA	MAC	Transmission Active

Table 11 Receive Direction

Control/ Status Bit	Register	Bit	Function
Control	MOCR	MRC	MR Bit Control
		MRE	Receive Interrupt (MDR) Enable
Status	MOSR	MDR	Data Received
		MER	End of Reception

Functional Description

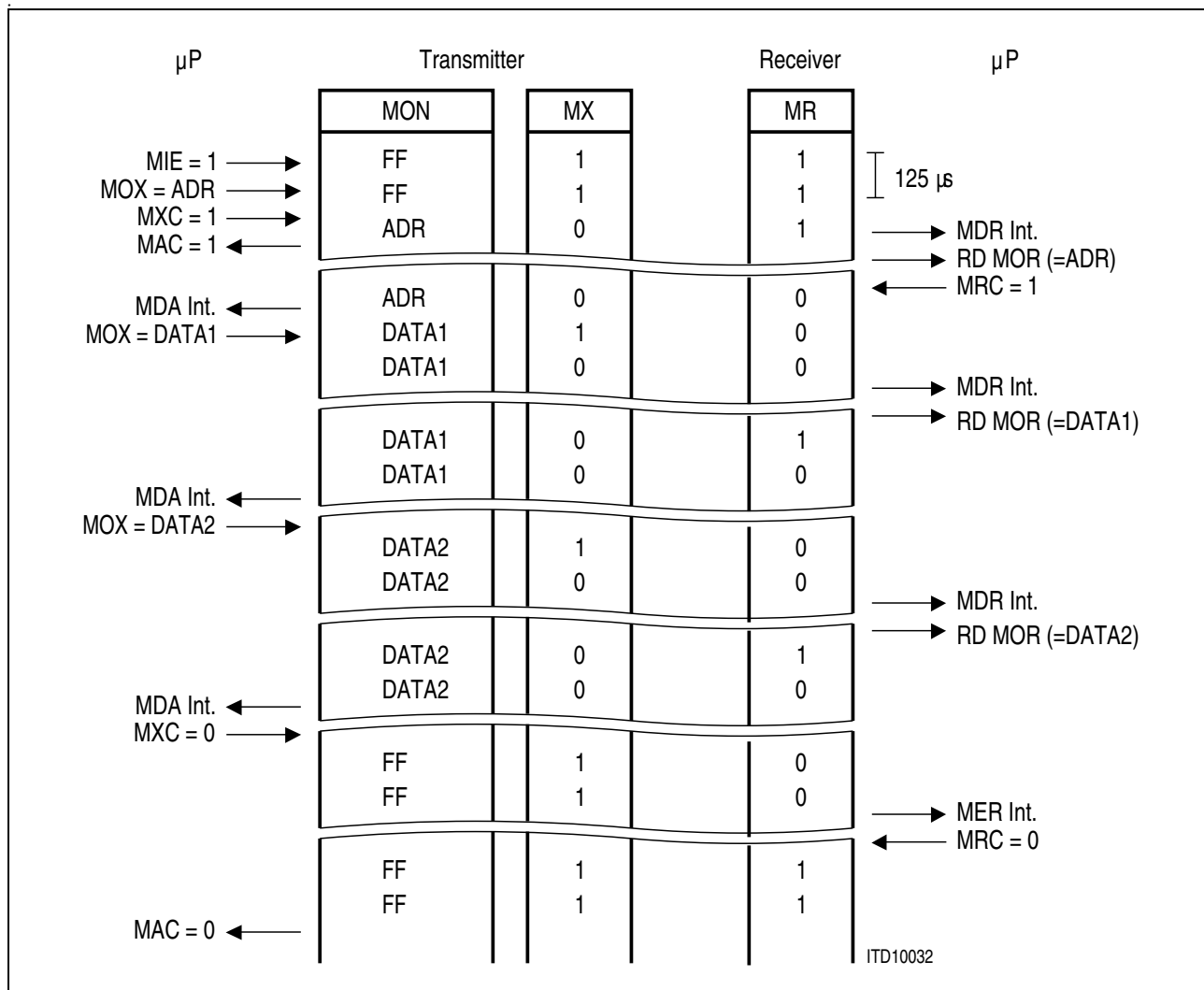

Figure 20 MONITOR Channel Protocol (IOM®-2)

Before starting a transmission, the microprocessor should verify that the transmitter is inactive, i.e. that a possible previous transmission has been terminated. This is indicated by a '0' in the MONITOR Channel Active MAC status bit.

After having written the MONITOR Data Transmit (MOX) register, the microprocessor sets the MONITOR Transmit Control bit MXC to '1'. This enables the MX bit to go active (0), indicating the presence of valid MONITOR data (contents of MOX) in the corresponding frame. As a result, the receiving device stores the MONITOR byte in its MONITOR Receive MOR register and generates a MDR interrupt status.

Alerted by the MDR interrupt, the microprocessor reads the MONITOR Receive (MOR) register. When it is ready to accept data (e.g. based on the value in MOR, which in a point-to-multipoint application might be the address of the destination device), it sets the MR control bit MRC to '1' to enable the receiver to store succeeding MONITOR channel bytes and acknowledge them according to the MONITOR channel protocol. In addition,

Functional Description

it enables other MONITOR channel interrupts by setting MONITOR Interrupt Enable (MIE) to '1'.

As a result, the first MONITOR byte is acknowledged by the receiving device setting the MR bit to '0'. This causes a MONITOR Data Acknowledge MDA interrupt status at the transmitter.

A new MONITOR data byte can now be written by the microprocessor in MOX. The MX bit is still in the active (0) state. The transmitter indicates a new byte in the MONITOR channel by returning the MX bit active after sending it once in the inactive state. As a result, the receiver stores the MONITOR byte in MOR and generates a new MDR interrupt status. When the microprocessor has read the MOR register, the receiver acknowledges the data by returning the MR bit active after sending it once in the inactive state. This in turn causes the transmitter to generate a MDA interrupt status.

This "MDA interrupt – write data – MDR interrupt – read data – MDA interrupt" handshake is repeated as long as the transmitter has data to send. Note that the MONITOR channel protocol imposes no maximum reaction times to the microprocessor.

When the last byte has been acknowledged by the receiver (MDA interrupt status), the microprocessor sets the MONITOR Transmit Control bit MXC to '0'. This enforces an inactive ('1') state in the MX bit. Two frames of MX inactive signifies the end of a message. Thus, a MONITOR Channel End of Reception MER interrupt status is generated by the receiver when the MX bit is received in the inactive state in two consecutive frames. As a result, the microprocessor sets the MR control bit MRC to 0, which in turn enforces an inactive state in the MR bit. This marks the end of the transmission, making the MONITOR Channel Active MAC bit return to '0'.

During a transmission process, it is possible for the receiver to ask a transmission to be aborted by sending an inactive MR bit value in two consecutive frames. This is effected by the microprocessor writing the MR control bit MRC to '0'. An aborted transmission is indicated by a MONITOR Channel Data Abort MAB interrupt status at the transmitter.

The MONITOR transfer protocol rules are summarized in the following section

- A pair of MX and MR in the inactive state for two or more consecutive frames indicates an **idle state** or an **end of transmission**.
- A **start of a transmission** is initiated by the transmitter by setting the MXC bit to '1' enabling the internal MX control. The receiver acknowledges the received first byte by setting the MR control bit to '1' enabling the internal MR control.
- The internal MX, MR control indicates or acknowledges a new byte in the MON slot by toggling MX, MR from the active to the inactive state for one frame.
- Two frames with the MR-bit set to inactive indicate a receiver request for **abort**.
- The transmitter can **delay a transmission** sequence by sending the same byte continuously. In that case the MX-bit remains active in the IOM[®]-2 frame following the first byte occurrence. Delaying a transmission sequence is only possible while the receiver MR-bit and the transmitter MX-bit are active.

Functional Description

- Since a **double last-look criterion** is implemented the receiver is able to receive the MON slot data at least twice (in two consecutive frames), the receiver waits for the acknowledge of the reception of two identical bytes in two successive frames.
- To control this handshake procedure a collision detection mechanism is implemented in the transmitter. This is done by making a **collision check** per bit on the transmitted MONITOR data and the MX bit.
- Monitor data will be transmitted repeatedly until its reception is acknowledged or the transmission time-out timer expires.
- Two frames with the MX bit in the inactive state indicates the **end of a message** (EOM).
- Transmission and reception of monitor messages can be performed simultaneously. This feature is used by the device to send back the response before the transmission from the controller is completed (the device does not wait for EOM from controller).

2.3.3.2 Error Treatment

In case the device does not detect identical monitor messages in two successive frames, transmission is not aborted. Instead the device will wait until two identical bytes are received in succession.

A transmission is aborted by the device if

- an error in the MR handshaking occurs
- a collision on the IOM[®]-2 bus of the MONITOR data or MX bit occurs
- the transmission time-out timer expires

A reception is aborted by the device if

- an error in the MX handshaking occurs or
- an abort request from the opposite device occurs

MX/MR Treatment in Error Case

In the master mode the MX/MR bits are under control of the microcontroller through MXC or MRC, respectively. An abort is indicated by an MAB interrupt or MER interrupt, respectively.

In the slave mode the MX/MR bits are under control of the device. An abort is always indicated by setting the MX/MR bit inactive for two or more IOM[®]-2 frames. The controller must react with EOM.

Figure 21 shows an example for an abort requested by the receiver, **Figure 22** shows an example for an abort requested by the transmitter and **Figure 23** shows an example for a successful transmission.

Functional Description

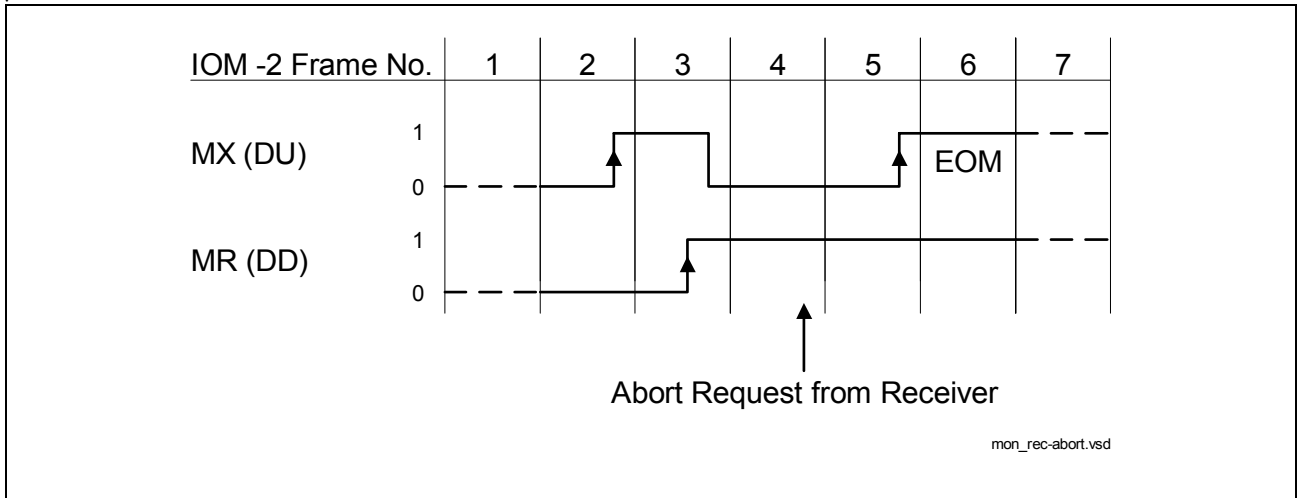

Figure 21 Monitor Channel, Transmission Abort requested by the Receiver

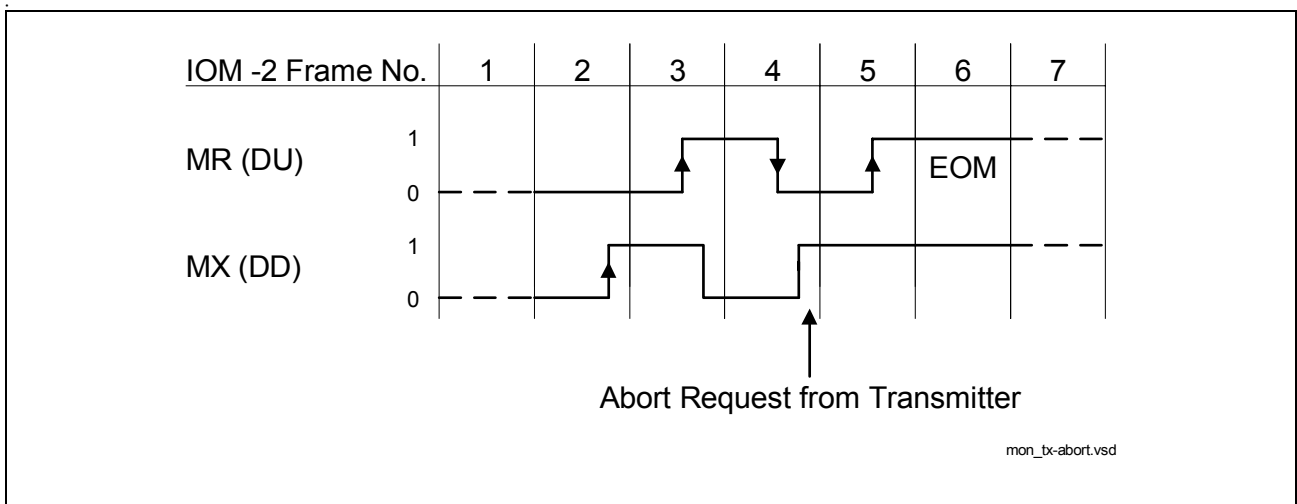

Figure 22 Monitor Channel, Transmission Abort requested by the Transmitter

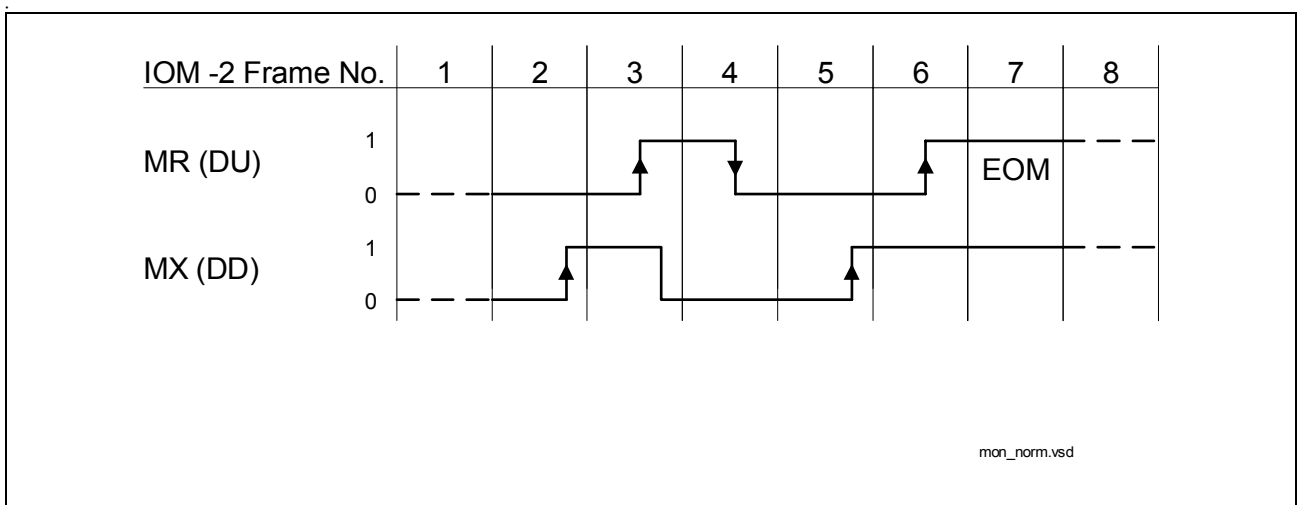

Figure 23 Monitor Channel, Normal End of Transmission

2.3.3.3 MONITOR Channel Programming as a Master Device

The master mode is selected by default if one of the microcontroller interfaces is selected. The monitor data is written by the microcontroller in the MOX register and transmitted via IOM[®]-2 DD(DU) line to the programmed/controlled device e.g. ARCOFI-BA PSB 2161. The transfer of the commands in the MON channel is regulated by the handshake protocol mechanism with MX, MR.

2.3.3.4 MONITOR Channel Programming as a Slave Device

MONITOR slave mode can be selected by pinstrapping the microcontroller interface pins according to [Table 4](#). All programming data required by the device is received in the MONITOR time slot on the IOM[®]-2 and is transferred to the MOR register. The transfer of the commands in the MON channel is regulated by the handshake protocol mechanism with MX, MR which is described in the previous [Chapter 2.3.3.1](#).

The first byte of the MONITOR message must contain in the higher nibble the MONITOR channel address code which is '1000' for the T-SMINT[®]I. The lower nibble distinguishes between a programming command and an identification command.

Identification Command

In order to be able to identify unambiguously different hardware designs of the T-SMINT[®]I by software, the following identification command is used:

DU 1st byte value	1	0	0	0	0	0	0	0
DU 2nd byte value	0	0	0	0	0	0	0	0

The T-SMINT[®]I responds to this identification sequence by sending a identification sequence:

DD 1st byte value	1	0	0	0	0	0	0	0	
DD 2nd byte value	0	0	DESIGN				<IDENT>		

DESIGN: six bit code, specific for each device in order to identify differences in operation (see [“ID - Identification Register” on Page 139](#)).

This identification sequence is usually done once, when the T-SMINT[®]I is connected for the first time. This function is used so that the software can distinguish between different possible hardware configurations. However this sequence is not compulsory.

Programming Sequence

The programming sequence is characterized by a '1' being sent in the lower nibble of the received address code. **The data structure after this first byte is equivalent to the structure of the serial control interface described in chapter [Chapter 2.1.1](#).**

Functional Description

DU 1st byte value	1	0	0	0	0	0	0	1
DU 2nd byte value	Header Byte							
DU 3rd byte value	R/W	Command/ Register Address						
DU 4th byte value	Data 1							
DU (nth + 3) byte value	Data n							

All registers can be read back when setting the R/W bit to '1'. The T-SMINT[®]I responds by sending his IOM[®]-2 specific address byte (81_h) followed by the requested data.

Note: Application Hint:

It is not allowed to disable the MX- and MR-control in the programming device at the same time! First, the MX-control must be disabled, then the μ C has to wait for an End of Reception before the MR-control may be disabled. Otherwise, the T-SMINT[®]I does not recognize an End of Reception.

2.3.3.5 Monitor Time-Out Procedure

To prevent lock-up situations in a MONITOR transmission a time-out procedure can be enabled by setting the time-out bit (TOUT) in the MONITOR configuration register (MCONF). An internal timer is always started when the transmitter must wait for the reply of the addressed device or for transmit data from the microcontroller. After 40 IOM[®]-2 frames (5 ms) without reply the timer expires and the transmission will be aborted with an EOM (End of Message) command by setting the MX bit to '1' for two consecutive IOM[®]-2 frames.

2.3.3.6 MONITOR Interrupt Logic

Figure 24 shows the interrupt structure of the MONITOR handler. The MONITOR Data Receive interrupt status MDR has two enable bits, MONITOR Receive interrupt Enable (MRE) and MR bit Control (MRC). The MONITOR channel End of Reception MER, MONITOR channel Data Acknowledged MDA and MONITOR channel Data Abort MAB interrupt status bits have a common enable bit MONITOR Interrupt Enable MIE.

MRE set to "0" prevents the occurrence of MDR status, including when the first byte of a packet is received. When MRE is set to "1" but MRC is set to "0", the MDR interrupt status is generated only for the first byte of a receive packet. When both MRE and MRC are set to "1", MDR is always generated and all received MONITOR bytes - marked by a 1-to-0 transition in MX bit - are stored. Additionally, a MRC set to "1" enables the control of the MR handshake bit according to the MONITOR channel protocol.

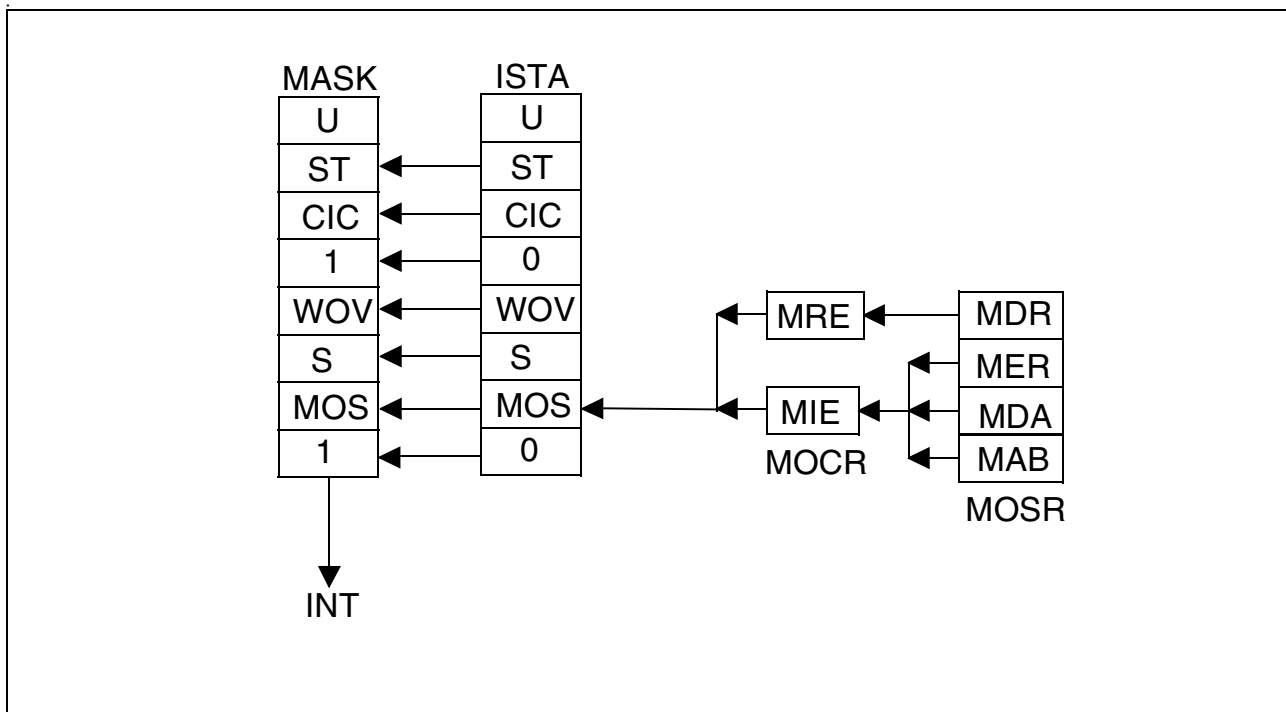

Figure 24 MONITOR Interrupt Structure

2.3.4 C/I Channel Handling

The Command/Indication channel carries real-time status information between the T-SMINT[®]1 and another device connected to the IOM[®]-2.

1) C/I0 channel lies in IOM[®]-2 channel 0 and access may be arbitrated via the TIC bus access protocol. In this case the arbitration is done in IOM[®]-2 channel 2.

The C/I0 channel is accessed via register CIR0 (received C/I0 data from DD) and register CIX0 (transmitted C/I0 data to DU). The C/I0 code is four bits long.

In the receive direction, the code from layer-1 is continuously monitored, with an interrupt being generated any time a change occurs (ISTA.CIC).

C/I0 only: a new code must be found in two consecutive IOM[®]-2 frames to be considered valid and to trigger a C/I code change interrupt status (double last look criterion).

In the transmit direction, the code written in CIX0 is continuously transmitted in C/I0.

2) A second C/I channel (called C/I1) lies in IOM[®]-2 channel 1 and is used to convey real time status information of the on-chip S-transceiver or an external device. The C/I1 channel consists of four or six bits in each direction. The width can be changed from 4 bit to 6 bit by setting bit CIX1.CICW.

Functional Description

In 4-bit mode 6-bits are written whereby the higher 2 bits must be set to “1” and 6-bits are read whereby only the 4 LSBs are used for comparison and interrupt generation (i.e. the higher two bits are ignored).

The C/I1 channel is accessed via registers CIR1 and CIX1. The connection of CIR1 and CIX1 to DD and DU, respectively, can be selected by setting bit CI_CR.DPS_CI1. A change in the received C/I1 code is indicated by an interrupt status without double last look criterion.

CIC Interrupt Logic

Figure 25 shows the CIC interrupt structure.

The two corresponding status bits CIC0 and CIC1 are read in CIR0 register. CIC1 can be individually disabled by clearing the enable bit CI1E in the CIX1 register. In this case the occurrence of a code change in CIR1 will not be displayed by CIC1 until the corresponding enable bit has been set to one.

Bits CIC0 and CIC1 are cleared by a read of CIR0.

An interrupt status is indicated every time a valid new code is loaded in CIR0 or CIR1. The CIR0 is buffered with a FIFO size of two. If a second code change occurs in the received C/I channel 0 before the first one has been read, immediately after reading of CIR0 a new interrupt will be generated and the new code will be stored in CIR0. If several consecutive codes are detected, only the first and the last code are obtained at the first and second register read, respectively.

For CIR1 no FIFO is available. The actual code of the received C/I channel 1 is always stored in CIR1.

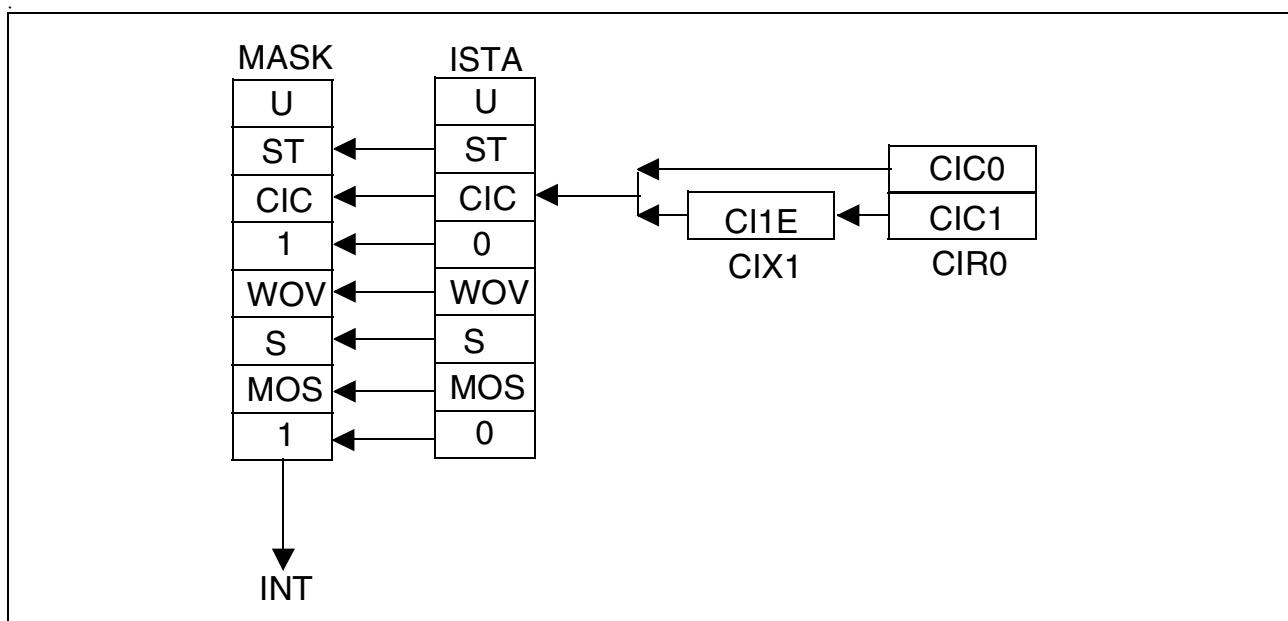

Figure 25 CIC Interrupt Structure

2.3.5 D-Channel Access Control

The upstream D-channel is arbitrated between the S-bus and external HDLC controllers via the TIC bus (S/G, BAC, TBA bits) according to the IOM[®]-2 Reference Guide¹⁾. Further to the implementation in the INTC-Q it is possible, to set the priority (8 or 10) of all HDLC-controllers connected to IOM[®]-2, which is particularly useful for use of the T-SMINT[®]I together with the UTAH.

2.3.5.1 Application Examples for D-Channel Access Control

Figure 26 and Figure 27 show different scenarios for the local D-channel arbitration between the S-bus and the microcontroller.

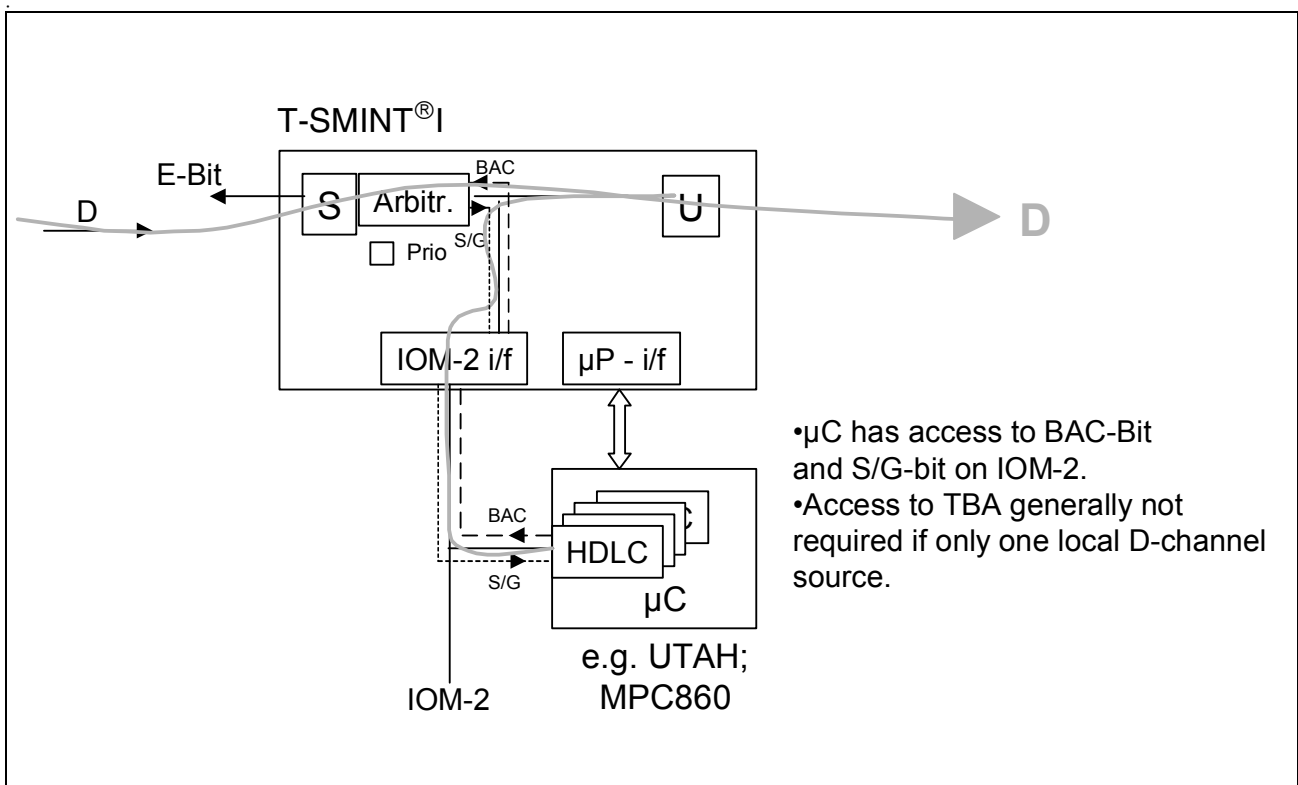

Figure 26 D-Channel Arbitration: μC with HDLC and Direct Access to TIC Bus

¹⁾ The A/B-bit is not supported by the U-transceiver

Functional Description

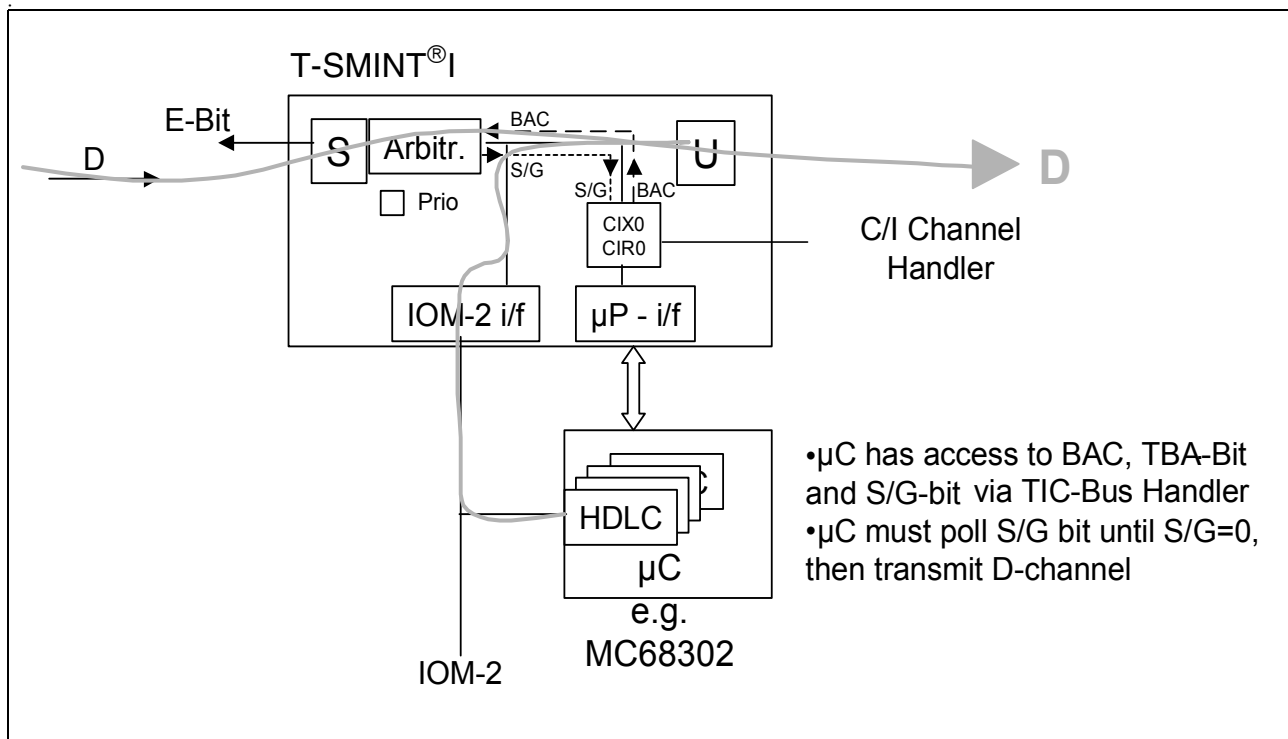

Figure 27 D-Channel Arbitration: μC with HDLC and no Access to TIC Bus

2.3.5.2 TIC Bus Handling

The TIC bus is implemented to organize the access to the C/I0-channel and to the D-channel from up to 7 D-channels HDLC controllers. The arbitration mechanism must be activated by setting MODEH.DIM2-0=00x.

The arbitration mechanism is implemented in the last octet in IOM[®]-2 channel 2 of the IOM[®]-2 interface (see [Figure 28](#)). An access request to the TIC bus may either be generated by software (μC access to the C/I0-channel via CIX0 register) or by an external D-channel HDLC controller (transmission of an HDLC frame in the D-channel). A software access request to the bus is effected by setting the BAC bit in register CIX0 to '1' (resulting in BAC = '0' on IOM[®]-2).

In the case of an access request by the T-SMINT[®]I, the Bus Accessed-bit BAC (bit 5 of last octet of CH2 on DU, see [Figure 28](#)) is checked for the status "bus free", which is indicated by a logical '1'. If the bus is free, the T-SMINT[®]I transmits its individual TIC bus address TAD programmed in the CIX0 register (CIX0.TBA2-0). While being transmitted the TIC bus address TAD is compared bit by bit with the value read back on DU. If a sent bit set to '1' is read back as '0' because of the access of an external device with a lower TAD, the T-SMINT[®]I withdraws immediately from the TIC bus, i.e. the remaining TAD bits are not transmitted. The TIC bus is occupied by the device which sends and reads back its address error-free. If more than one device attempt to seize the bus simultaneously, the one with the lowest address values wins. This one will set BAC=0 on TIC bus and starts D-channel transmission in the same frame.

Functional Description

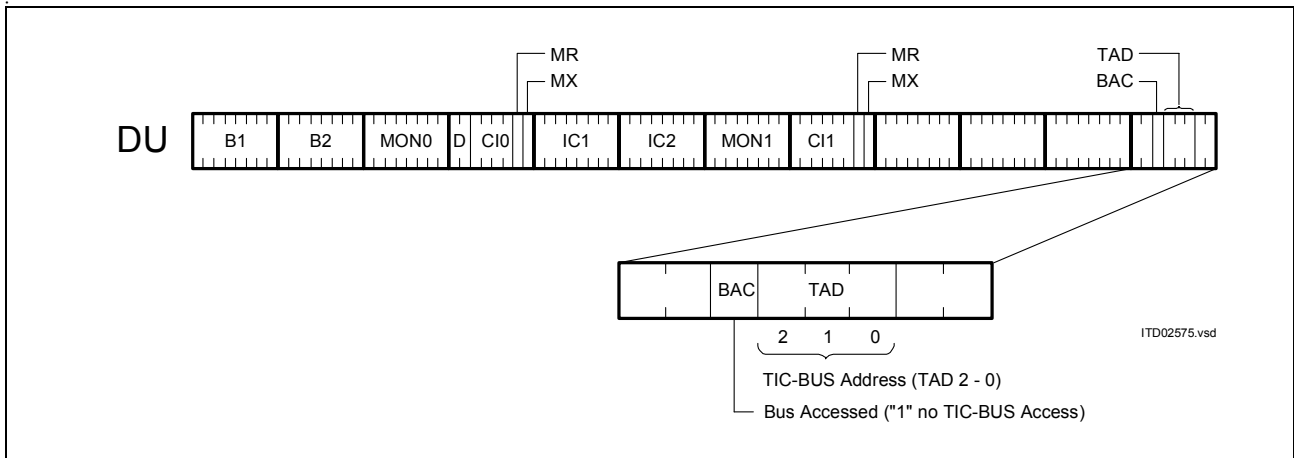

Figure 28 Structure of Last Octet of Ch2 on DU

When the TIC bus is seized by the T-SMINT[®]I, the bus is identified to other devices as occupied via the DU Ch2 Bus Accessed-bit state '0' until the access request is withdrawn. After a successful bus access, the T-SMINT[®]I is automatically set into a lower priority class, that is, a new bus access cannot be performed until the status "bus free" is indicated in two successive frames.

If none of the devices connected to the IOM[®]-2 interface request access to the D and C/I0 channels, the TIC bus address 7 will be present. The device with this address will therefore have access, by default, to the D and C/I0 channels.

Note: Bit BAC (CIX0 register) should be reset by the μ C when access is no more requested, to grant other devices access to the D and C/I0 channels.

2.3.5.3 Stop/Go Bit Handling

The availability of the DU D channel is indicated in bit 5 "Stop/Go" (S/G) of the last octet in DD channel 2 (Figure 29). The arbitration mechanism must be activated by setting MODEH.DIM2-0=0x1.

S/G = 1 : stop

S/G = 0 : go

The Stop/Go bit is available to other layer-2 devices connected to the IOM[®]-2 interface to determine if they can access the D channel in upstream direction.

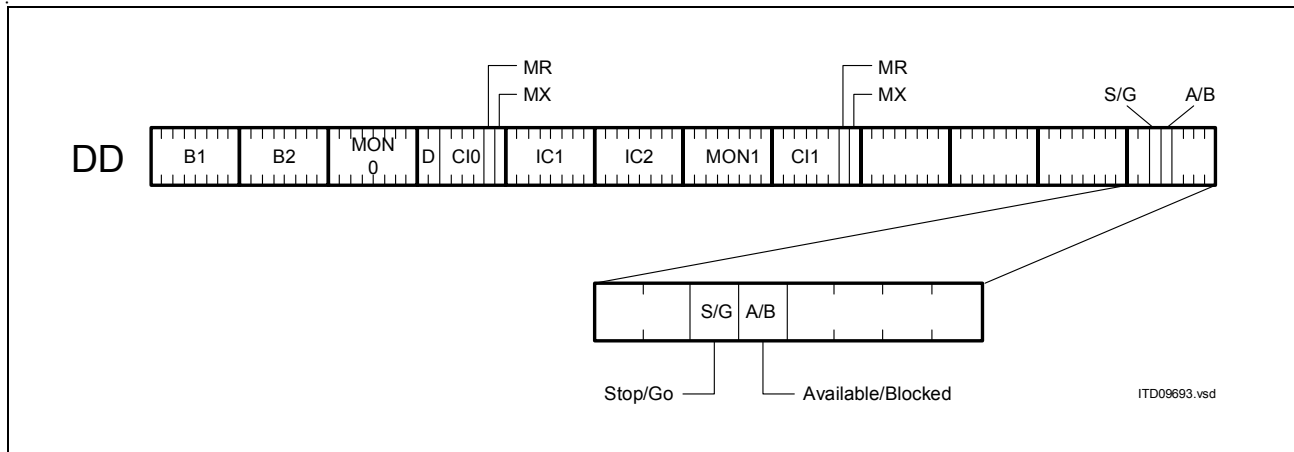

Figure 29 Structure of Last Octet of Ch2 on DD

2.3.5.4 D-Channel Arbitration

In intelligent NT applications (selected via register S_MODE.MODE2-0) the T-SMINT[®]I has to share the upstream D-channel with one or more D-channel controllers on the IOM[®]-2 interface and with all connected TEs on the S interface.

The S-transceiver incorporates an elaborate state machine for D-channel priority handling on IOM[®]-2 ([Chapter 2.3.5.5](#)). For the access to the D-channel a similar arbitration mechanism as on the S interface (writing D-bits, reading back E-bits) is performed for all D-channel sources on IOM[®]-2. Due to this an equal and fair access is guaranteed for all D-channel sources on both the S interface and the IOM[®]-2 interface. The access to the upstream D-channel is handled via the S/G bit for the HDLC controllers and via E-bit for all connected terminals on S (E-bits are inverted to block the terminals on S). Furthermore, if more than one HDLC source is requesting D-channel access on IOM[®]-2 the TIC bus mechanism is used (see [Chapter 2.3.5.2](#)).

The arbiter permanently counts the “1s” in the upstream D-channel on IOM[®]-2. If the necessary number of “1s” is counted and an HDLC controller on IOM[®]-2 requests upstream D-channel access (BAC bit is set to 0), the arbiter allows this D-channel controller immediate access and blocks other TEs on S (E-bits are inverted). Similar as on the S-interface the priority for D-channel access on IOM[®]-2 can be configured to 8 or 10 (S_CMD.DPRIO).

The configuration settings of the T-SMINT[®]I in intelligent NT applications are summarized in [Table 12](#).

Table 12 T-SMINT[®]I Configuration Settings in Intelligent NT Applications

Functional Block	Configuration Description	Configuration Setting
Layer 1	Select Intelligent NT mode	S-Transceiver Mode Register: S_MODE.MODE0 = 0 (NT state machine) or S_MODE.MODE0 = 1 (LT-S state machine) S_MODE.MODE1 = 1 S_MODE.MODE2 = 1
Layer 2	Enable S/G bit and TIC bus evaluation	D-channel Mode Register: MODEH.DIM2-0 = 001

Note: For mode selection in the S_MODE register the MODE1/2 bits are used to select intelligent NT mode, MODE0 selects NT or LT-S state machine.

With the configuration settings shown above the T-SMINT[®]I in intelligent NT applications provides for equal access to the D-channel for terminals connected to the S-interface and for D-channel sources on IOM[®]-2.

2.3.5.5 State Machine of the D-Channel Arbiter

Figure 30 gives a simplified view of the state machine of the D-channel arbiter. CNT is the number of '1' on the IOM[®]-2 D-channel and BAC corresponds to the BAC-bit on IOM[®]-2. The number n depends on configuration settings (selected priority 8 or 10) and the condition of the previous transmission, i.e. if an abort was seen (n = 8 or 10, respectively) or if the last transmission was successful (n = 9 or 11, respectively).

Functional Description

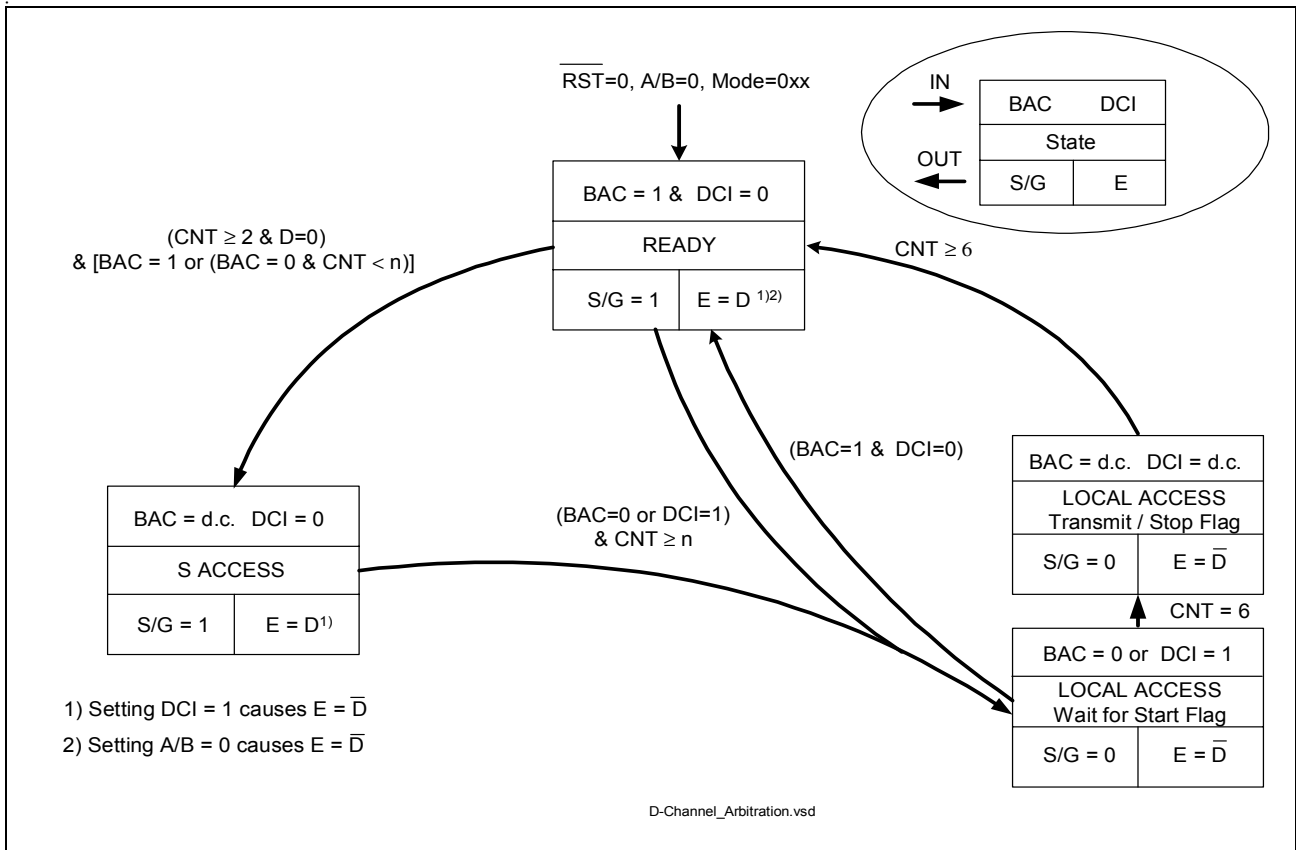

Figure 30 State Machine of the D-Channel Arbiter (Simplified View)¹⁾

1. Local D-Channel Controller Transmits Upstream

In the initial state ('Ready' state) neither the local D-channel sources nor any of the terminals connected to the S-bus transmit in the D-channel.

The T-SMINT[®] S-transceiver thus receives BAC = "1" (IOM[®]-2 DU line) and transmits S/G = "1" (IOM[®]-2 DD line). The access will then be established according to the following procedure:

- Local D-channel source verifies that BAC bit is set to ONE (currently no bus access).
- Local D-channel source issues TIC bus address and verifies that no controller with higher priority requests transmission (TIC bus access must always be performed even if no other D-channel sources are connected to IOM[®]-2).
- Local D-channel source issues BAC = "0" to block other sources on IOM[®]-2 and to announce D-channel access.
- T-SMINT[®] S-transceiver pulls S/G bit to ZERO ('Local Access' state) as soon as CNT ≥ n (see note) to allow sending D-channel data from the entitled source.

¹⁾ If the S-transceiver is reset by SRES.RES_S = '1' or disabled by S_CONF0.DIS_TR = '1', then the D-channel arbiter is in state Ready (S/G = '1'), too. The S/G evaluation of the HDLC has to be disabled in this case; otherwise, the HDLC is not able to send data.

Functional Description

T-SMINT[®]I S-transceiver transmits inverted echo channel (E bits) on the S-bus to block all connected S-bus terminals ($E = \bar{D}$).

- Local D-channel source commences with D data transmission on IOM[®]-2 as long as it receives S/G = "0".
- After D-channel data transmission is completed the controller sets the BAC bit to ONE.
- T-SMINT[®]I S-transceiver transmits non-inverted echo ($E = D$).
- T-SMINT[®]I S-transceiver pulls S/G bit to ONE ('Ready' state) to block the D-channel controller on IOM[®]-2.

Note: If right after D-data transmission the D-channel arbiter goes to state 'Ready' and the local D-channel source wants to transmit again, then it may happen that the leading '0' of the start flag is written into the D-channel before the D-channel source recognizes that the S/G bit is pulled to '1' and stops transmission. In order to prevent unintended transitions to state 'S-Access', the additional condition $CNT \geq 2$ is introduced. As soon as $CNT \geq n$, the S/G bit is set to '0' and the D-channel source may start transmission again (if TIC bus is occupied). This allows an equal access for D-channel sources on IOM[®]-2 and on the S interface.

2. Terminal Transmits D-Channel Data Upstream

The initial state is identical to that described in the last paragraph. When one of the connected S-bus terminals needs to transmit in the D-channel, access is established according to the following procedure:

- S-transceiver recognizes that the D-channel on the S-bus is active via $D = '0'$.
- S-transceiver transfers S-bus D-channel data transparently through to the upstream IOM[®]-2 bus.

2.3.6 Activation/Deactivation of IOM[®]-2 Interface

The deactivation procedure of the IOM[®]-2 interface is shown in Figure 31. After detecting the code DI (Deactivation Indication) the T-SMINT[®]I responds by transmitting DC (Deactivation Confirmation) during subsequent frames and stops the timing signals after the fourth frame. The clocks stop at the end of the C/I-code in IOM[®]-2 channel 0.

Functional Description

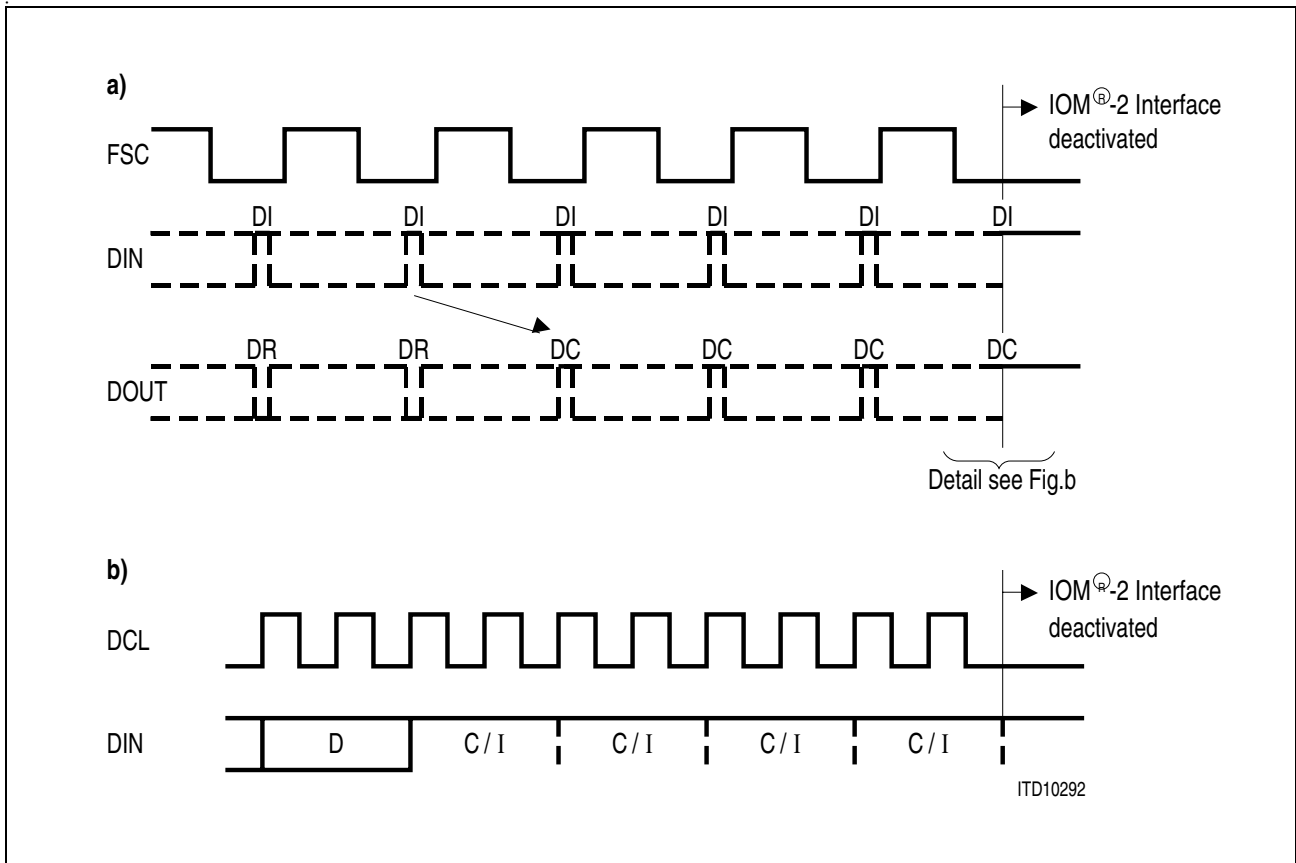

Figure 31 Deactivation of the IOM[®]-2 Clocks

Conditions for Power-Down

If none of the following conditions is true, the IOM[®]-2 interface can be switched off, reducing power consumption to a minimum.

- S-transceiver is not in state 'Deactivated'
- Signal $\overline{\text{INFO0}}$ on the S-interface
- Uk0-transceiver is not in state 'Deactivated'
- Pin DU is low (either at the IOM[®]-2 interface or via IOM_CR.SPU)
- External pin $\overline{\text{EAW}}$ External Awake is low
- Bit MODE 1.CFS = '0'
- Stop on the correct place in the IOM[®]-2 frame. DCL must be low during power down (stop on falling edge of DCL) (see **Figure 31**).

A deactivated IOM[®]-2 can be reactivated by one of the following methods:

- Pulling pin DU line low:
 - directly at the IOM[®]-2 interface
 - via the μP interface with "Software Power Up" (IOM_CR:SPU bit)
- Pulling pin $\overline{\text{EAW}}$ 'External Awake' low
- Setting 'Configuration Select' MODE1:CFS bit = '0'
- Level detection at the S-interface

- Activation from the U-interface

2.4 U-Transceiver

The statemachine of the U-Transceiver is compatible to the NT state machine in the PEB 8090 documentation [9], but includes some minor changes for simplification and compliance to Ref. [1].

The U-transceiver is configured and controlled via the registers described in [Chapter](#) . The U-transceiver is always in IOM[®]-2 channel 0.

2.4.1 4B3T Frame Structure

The 4B3T U-interface performs full duplex data transmission and reception at the U-reference point according to ETSI TS 102 080 and FTZ 1TR 220. It applies the 4B3T block code together with adaptive echo cancelling and equalization. Transmission performance shall be such, that it meets all ETSI and FTZ test loops with margin.

The U-interface is designed for data transmission on twisted pair wires in local telephone loops, with basic access to ISDN and a user bit rate of 144 kbit/s.

The following information is transmitted over the twisted pair:

- Bidirectional:
 - B1, B2, D data channels
 - 120 kHz Symbol clock
 - 1 kHz Frame
 - Activation
 - 1 kbit/s Transparent Channel (M symbol), (not implemented)
- From LT to NT side:
 - Power feeding
 - Deactivation
 - Remote control of test loops (M symbol)
- From NT to LT side:
 - Indication of monitored code violations (M symbol)

Performance Requirements according to FTZ 1 TR 220 (August 1991):

On the U-interface, the following transmission ranges are achieved without additional signal regeneration on the loop (bit error rate $\leq 10^{-7}$):

- with noise: ≥ 4.2 km on wires of 0.4 mm diameter and ≥ 8 km on 0.6 mm wires
- without noise: ≥ 5 km on wires of 0.4 mm diameter and ≥ 10 km on 0.6 mm wires

Note: Typical attenuation of FTZ wires of 0.4 mm diameter is about 7dB/km in contrast to ETSI wires of 0.4 mm with about 8dB/km.

The transmission ranges can be doubled by inserting a repeater for signal regeneration.

Functional Description

Performance requirements according to ETSI TS 102 080 are met, too.

1 ms frames are transmitted via the U-interface, each consisting of:

- 108 symbols: 144 bit scrambled and coded B1 + B2 + D data
- 11 symbols: Barker code for both symbol and frame synchronization (not scrambled)
- 1 symbol: Ternary maintenance symbol (not scrambled)

The 108 user data symbols are split into four equally structured groups. Each group (27 ternary symbols, resp. 36 bits) contains the user data of two IOM[®]-2 frames in the same order (8B + 8B + 2D + 8B + 8B + 2D).

Different syncwords are used for each direction:

- Downstream from LT to NT + + + - - - + - - + -
- Upstream from NT to LT - + - - - + - - - + + +

On the NT side, the transmitted Barker code begins 60 symbols after the received Barker code and vice versa.

D ₁ ... D ₈	Ternary 2B + D data of IOM [®] -2 frames 1 ... 8
M	Maintenance symbol
+, -	Syncword

Functional Description

Table 13 Frame Structure A for Downstream Transmission LT to NT

1	2	3	4	5	6	7	8	9	10	11	12
D ₁	D ₁	D ₁	D ₁	D ₁	D ₁	D ₁	D ₁	D ₁	D ₁	D ₁	D ₁
13	14	15	16	17	18	19	20	21	22	23	24
D _{1/2}	D _{1/2}	D _{1/2}	D ₂	D ₂	D ₂	D ₂	D ₂	D ₂	D ₂	D ₂	D ₂
25	26	27	28	29	30	31	32	33	34	35	36
D ₂	D ₂	D ₂	D ₃	D ₃	D ₃	D ₃	D ₃	D ₃	D ₃	D ₃	D ₃
37	38	39	40	41	42	43	44	45	46	47	48
D ₃	D ₃	D ₃	D _{3/4}	D _{3/4}	D _{3/4}	D ₄	D ₄	D ₄	D ₄	D ₄	D ₄
49	50	51	52	53	54	55	56	57	58	59	60
D ₄	D ₄	D ₄	D ₄	D ₄	D ₄	D ₅	D ₅	D ₅	D ₅	D ₅	D ₅
61	62	63	64	65	66	67	68	69	70	71	72
D ₅	D ₅	D ₅	D ₅	D ₅	D ₅	D _{5/6}	D _{5/6}	D _{5/6}	D ₆	D ₆	D ₆
73	74	75	76	77	78	79	80	81	82	83	84
D ₆	D ₆	D ₆	D ₆	D ₆	D ₆	D ₆	D ₆	D ₆	D ₇	D ₇	D ₇
85	86	87	88	89	90	91	92	93	94	95	96
M	D ₇	D ₇	D ₇	D ₇	D ₇	D ₇	D ₇	D ₇	D ₇	D _{7/8}	D _{7/8}
97	98	99	100	101	102	103	104	105	106	107	108
D _{7/8}	D ₈	D ₈	D ₈	D ₈	D ₈	D ₈	D ₈	D ₈	D ₈	D ₈	D ₈
109	110	111	112	113	114	115	116	117	118	119	120
D ₈	+	+	+	-	-	-	+	-	-	+	-

Functional Description

Table 14 Frame Structure B for Upstream Transmission NT to LT

1	2	3	4	5	6	7	8	9	10	11	12
U ₁	U ₁	U ₁	U ₁	U ₁	U ₁	U ₁	U ₁	U ₁	U ₁	U ₁	U ₁
13	14	15	16	17	18	19	20	21	22	23	24
U _{1/2}	U _{1/2}	U _{1/2}	U ₂	U ₂	U ₂	U ₂	U ₂	U ₂	U ₂	U ₂	U ₂
25	26	27	28	29	30	31	32	33	34	35	36
M	U ₂	U ₂	U ₂	U ₃	U ₃	U ₃	U ₃	U ₃	U ₃	U ₃	U ₃
37	38	39	40	41	42	43	44	45	46	47	48
U ₃	U ₃	U ₃	U ₃	U _{3/4}	U _{3/4}	U _{3/4}	U ₄	U ₄	U ₄	U ₄	U ₄
49	50	51	52	53	54	55	56	57	58	59	60
U ₄	-	+	-	-	+	-	-	-	+	+	+
61	62	63	64	65	66	67	68	69	70	71	72
U ₄	U ₄	U ₄	U ₄	U ₄	U ₄	U ₅	U ₅	U ₅	U ₅	U ₅	U ₅
73	74	75	76	77	78	79	80	81	82	83	84
U ₅	U ₅	U ₅	U ₅	U ₅	U ₅	U _{5/6}	U _{5/6}	U _{5/6}	U ₆	U ₆	U ₆
85	86	87	88	89	90	91	92	93	94	95	96
U ₆	U ₆	U ₆	U ₆	U ₆	U ₆	U ₆	U ₆	U ₆	U ₇	U ₇	U ₇
97	98	99	100	101	102	103	104	105	106	107	108
U ₇	U ₇	U ₇	U ₇	U ₇	U ₇	U ₇	U ₇	U ₇	U _{7/8}	U _{7/8}	U _{7/8}
109	110	111	112	113	114	115	116	117	118	119	120
U ₈	U ₈	U ₈	U ₈	U ₈	U ₈	U ₈	U ₈	U ₈	U ₈	U ₈	U ₈

U₁ ... U₈ Ternary 2B + D data of IOM[®]-2 frames 1... 8

M Maintenance symbol

+, - Syncword

2.4.2 Maintenance Channel

The 4B3T frame structure provides a 1 kbit/s M(aintenance)-channel for the transfer of remote loopback commands and error indications.

Loopback Commands

The LT station uses the M-channel to request remote loopbacks. Loopback commands are coded with a series of '0' and '+' symbols.

- A continuous series of '+' requests for loopback 2 activation in the NT
- A continuous series of '0' requests for deactivation of any loopback

The NT station reacts as soon as the pattern has been detected in 8 consecutive symbols.

Error Indications

The NT U-transceiver reports line code violations via the M-channel to the exchange by setting one M-Bit to '+' polarity.

Transparent Messages

The exchange of Transparent Messages via the Transparent Channel is not supported by the T-SMINT®I.

2.4.3 Coding from Binary to Ternary Data

Each 4 bit block of binary data is coded into 3 ternary symbols of MMS 43 block code according to [Table 15](#).

The number of the next column to be used, is given at the right hand side of each block. The left hand signal elements in the table (both ternary and binary) are transmitted first.

Table 15 MMS 43 Coding Table

	S1	S2	S3	S4
t →	t →	t →	t →	t →
0 0 0 1	0 - + 1	0 - + 2	0 - + 3	0 - + 4
0 1 1 1	- 0 + 1	- 0 + 2	- 0 + 3	- 0 + 4
0 1 0 0	- + 0 1	- + 0 2	- + 0 3	- + 0 4
0 0 1 0	+ - 0 1	+ - 0 2	+ - 0 3	+ - 0 4
1 0 1 1	+ 0 - 1	+ 0 - 2	+ 0 - 3	+ 0 - 4
1 1 1 0	0 + - 1	0 + - 2	0 + - 3	0 + - 4
1 0 0 1	+ - + 2	+ - + 3	+ - + 4	- - - 1

Functional Description

Table 15 MMS 43 Coding Table

				S1	S2	S3	S4												
0	0	1	1	0	0	+	2	0	0	+	3	0	0	+	4	-	-	0	2
1	1	0	1	0	+	0	2	0	+	0	3	0	+	0	4	-	0	-	2
1	0	0	0	+	0	0	2	+	0	0	3	+	0	0	4	0	-	-	2
0	1	1	0	-	+	+	2	-	+	+	3	-	-	+	2	-	-	+	3
1	0	1	0	+	+	-	2	+	+	-	3	+	-	-	2	+	-	-	3
1	1	1	1	+	+	0	3	0	0	-	1	0	0	-	2	0	0	-	3
0	0	0	0	+	0	+	3	0	-	0	1	0	-	0	2	0	-	0	3
0	1	0	1	0	+	+	3	-	0	0	1	-	0	0	2	-	0	0	3
1	1	0	0	+	+	+	4	-	+	-	1	-	+	-	2	-	+	-	3

2.4.4 Decoding from Ternary to Binary Data

Decoding is done in the reverse manner of coding. The received blocks of 3 ternary symbols are converted into blocks of 4 bits. The decoding algorithm is given in [Table 16](#).

As in the encoding table, the left hand symbol of each block (both binary and ternary) is the first bit and the right hand is the last. If a ternary block "0 0 0" is received, it is decoded to binary "0 0 0 0". This pattern usually occurs only during deactivation.

Table 16 4B3T Decoding Table

Ternary Block			Binary Block			
0 0 0,	+ 0 +,	0 - 0	0	0	0	0
0 - +			0	0	0	1
+ - 0			0	0	1	0
0 0 +,	- - 0		0	0	1	1
- + 0			0	1	0	0
0 + +,	- 0 0		0	1	0	1
- + +,	- - +		0	1	1	0
- 0 +			0	1	1	1
+ 0 0,	0 - -		1	0	0	0
+ - +,	- - -		1	0	0	1
+ + -,	+ - -		1	0	1	0
+ 0 -			1	0	1	1
+ + +,	- + -		1	1	0	0

Functional Description

Table 16 4B3T Decoding Table

0 + 0,	- 0 -	1	1	0	1
0 + -		1	1	1	0
+ + 0,	0 0 -	1	1	1	1

2.4.4.1 Monitoring of Code Violations

The running digital sum monitor (RDSM) computes the running digital sum from the received ternary symbols by adding the polarity of the received user data (+ 1, 0, -1). At the end of each block, the running digital sum is supposed to reflect the number of the next column in [Table 15](#).

A code violation has occurred if the running digital sum is less than one or more than four at the end of a ternary block, or if the ternary block 0 0 0 (three user symbols with zero polarity) is found in the received data.

If at the end of a ternary block no error was found, the running digital sum retains its current value. If the counter value is greater than 4, it is set to 4 at the beginning of the next ternary block, if its value is 0 or less, it is set to one. So after a code violation has been detected, the RDSM synchronizes itself within a period depending on the received data pattern. Note there are some transmission errors which do not cause a code violation.

2.4.4.2 Block Error Counter (RDS Error Counter)

The T-SMINT[®]I provides a block error counter. This feature allows monitoring the transmission quality on the U-interface.

On the NT side a block error is given, if a U-frame with at least one code violation has been detected (near-end block error). In the following frame the NT transmits a positive M-symbol upstream.

On the LT side a block error is given, if a U-frame with at least one code violation has been detected (near-end block error) or a positive M-symbol has been received from the NT (far-end block error).

The current status of the block error counter can be retrieved by the system interface. When the block error counter is read (register RDS), it is automatically reset. The counter is enabled in all states listed in [Table 17](#) and reset in all other states. The counter is saturated at its maximum value (255).

Table 17 Active States

SBC Synchronizing
Wait for INFO U4H
Transparent

Functional Description

Note that every frame with a detected code violation causes about 10 to 20 binary bit errors on average. So a bit error rate of 10^{-7} in both directions is equivalent to 2 detected frame errors within 1000 s in the LT (1 frame error detected in the NT and transmitted via M-symbol).

2.4.5 Scrambler / Descrambler

Scrambler

The binary transmit data from the IOM[®]-2 interface is scrambled with a polynomial of 23 bits, before it is sent to the 4B3T coder. The scrambler polynomial is::

$$z^{-23} + z^{-18} + 1$$

Descrambler

The received data (after decoding from ternary to binary) is multiplied with a polynomial of 23 bits in order to recover the original data before it is forwarded to the IOM[®]-2 interface. The descrambler is self synchronized after 23 symbols. The descrambler polynomial is::

$$z^{-23} + z^{-5} + 1$$

The scrambling / descrambling process is controlled fully by the T-SMINT[®]I. Hence, no influence can be taken by the user.

2.4.6 Command/Indication Codes

Both commands and indications depend on the data direction. **Table 18** presents all defined C/I codes. A new command or indication will be recognized as valid after it has been detected in two successive IOM[®]-2 frames (double last-look criterion).

Note: Unconditional C/I-commands must be applied for at least 4 IOM[®]-2 frames for reliable recognition by the U-transceiver.

Indications are strictly state orientated. Refer to the state diagrams in the following sections for commands and indications applicable in various states.

Table 18 C/I Codes

Code	IN	OUT
0000	TIM	DR
0001	–	–
0010	–	–

Functional Description

0011	LTD	–
0100	–	RSY
0101	SSP	–
0110	DT	–
0111	–	–
1000	AR	AR
1001	reserved ¹⁾	–
1010	–	ARL
1011	–	–
1100	AI	AI
1101	RES	–
1110	–	AIL
1111	DI	DC

¹⁾ C/I code '1010' must not be input to the U-transceiver.

AI	Activation Indication	DI	Deactivation Indication.
AIL	Activation Indication Loop 2	DR	Deactivation Request
AR	Activation Request	LTD	LT Disable
ARL	Activation Request Local Loop	RES	Reset
DT	Data Through Mode	RSY	Resynchronization Indication
DC	Deactivation Confirmation	SSP	Send-Single-Pulses
		TIM	Timing Request

2.4.7 State Machine for Activation and Deactivation

2.4.7.1 State Machine Notation

The following state diagram describes all the actions/reactions resulting from any command or detected signal and resulting from the various operating modes.

The states with its inputs and outputs are interpreted as shown below:

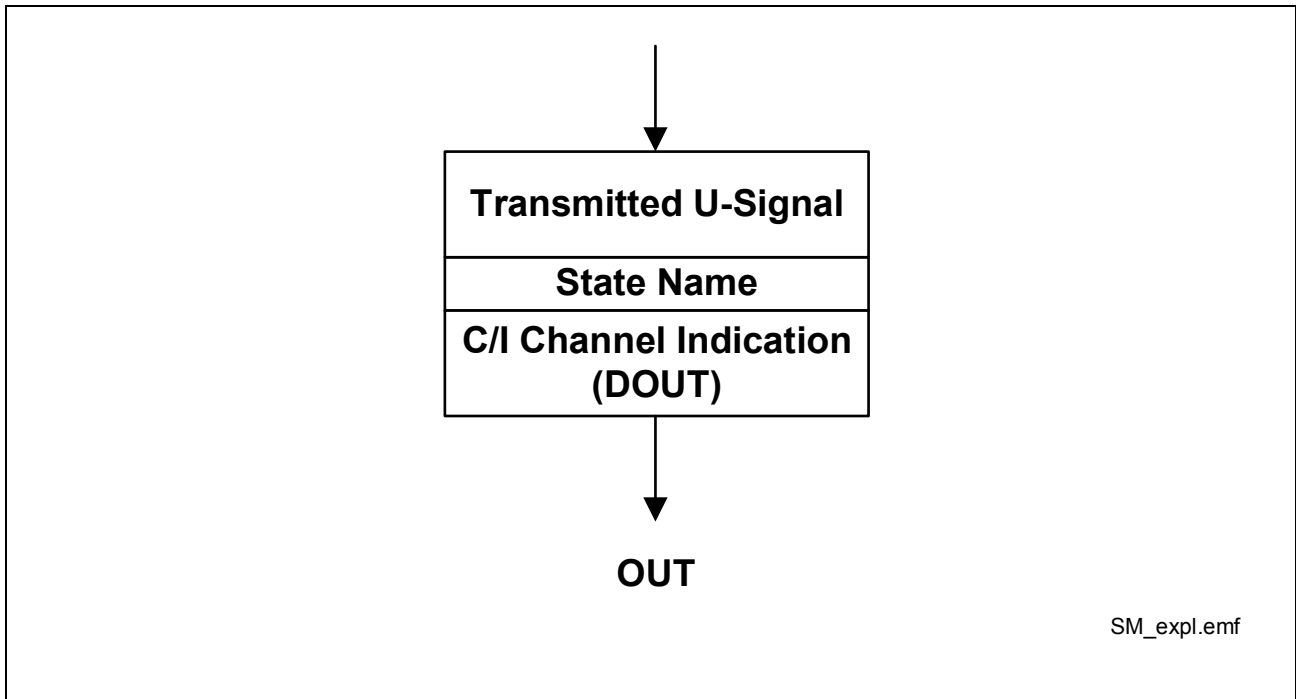

Figure 32 State Diagram Example

Each state has one or more transitions to other states. These transitions depend on certain conditions which are noted next to the transition lines. These conditions are the only possibility to leave a state. If more conditions have to be fulfilled together, they are put into parentheses with an AND operator (&). If more than one condition leads to the same transition, they are put into parentheses with an OR operator (|). The meaning of a condition may be inverted by the NOT operator (/). Only the described states and transitions exist.

At some transitions, an internal timer is started. The start of a timer is indicated by TxS ('x' is the timer number). Transitions that are caused if a timer has expired are labelled by TxE.

Some conditions lead to the same target state. To reduce the number of lines and the complexity of the figures, a state named "ANY STATE" acts on behalf of all state.

The state machines are designed to cope with all ISDN devices with IOM[®]-2 standard interfaces. Undefined situations are excluded. In any case, the involved devices will enter defined conditions as soon as the line is deactivated.

2.4.7.2 Awake Protocol

For the awake process two signals are defined 'U1W' and 'U2W'. Depending on the call direction (up-, downstream) U1W and U2W are interpreted as awake or acknowledge signals (see figures below).

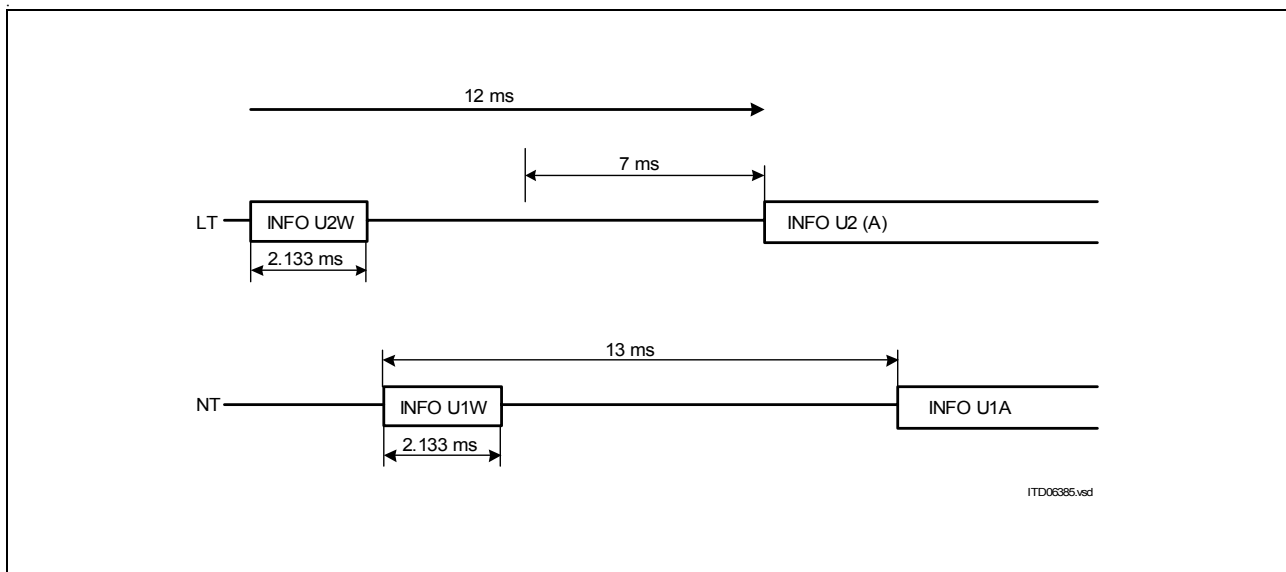

Figure 33 Awake Procedure initiated by the LT

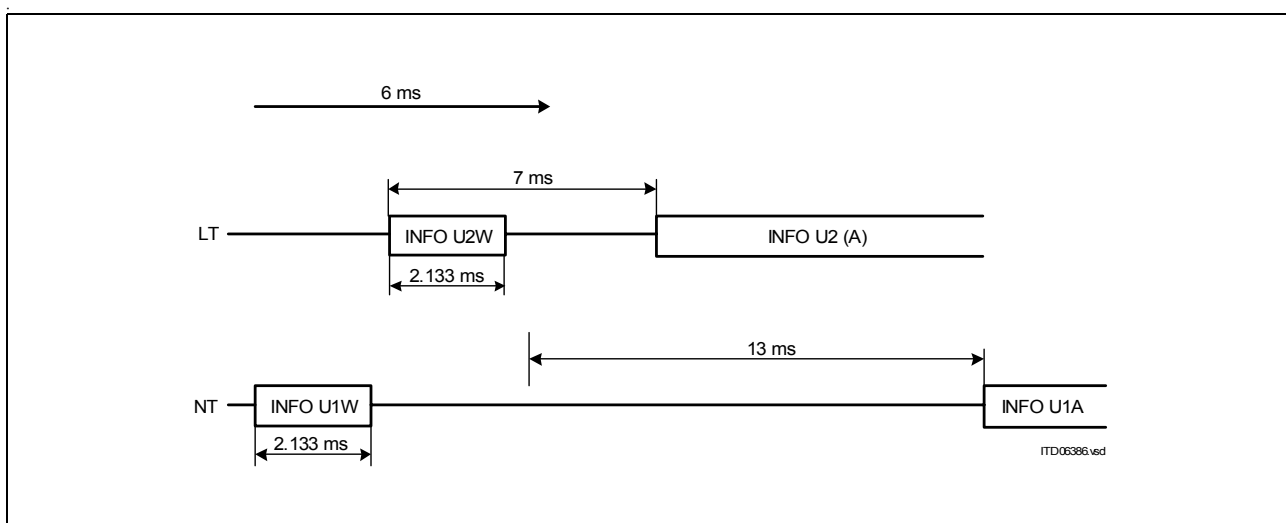

Figure 34 Awake Procedure initiated by the NT

Acting as Calling Station

After sending the awake signal, the awaking U-transceiver waits for the acknowledge. After 12 ms, the awake signal is repeated, if no acknowledge has been recognized.

If an acknowledge signal has been recognized, the U-transceiver waits for its possible repetition (in case of previous coincidence of two awake signals). If no repetition was detected, the U-transceiver starts transmitting U2 with a delay of 7 ms.

If such a repetition is detected, the U-transceiver interprets it as an awake signal and behaves like a device awoken by the far end.

Functional Description**Acknowledging a Wake-Up Call**

If a deactivated device detects an awake signal on U, an acknowledge signal is sent out. After that, the U-transceiver waits for a possible repetition of the awake signal (in case the acknowledge hasn't been recognized).

If no repetition is found, the awoken U-transceiver starts sending U2 after 7 ms from detecting the awake signal. If a repeated awake signal is found, the procedure in the awoken U-transceiver starts again.

Functional Description

Table 19 Differences to the former NT-SM of the IEC-T/NTC-T

No.	State/ Signal	Change	Comment
1.	State 'Deact. Request Rec.'	split into 3 states - 'Pend. Deactivation 1' - 'Reset' State - 'Test' State	simplifies SM implementation
2.	State 'Loss of Framing'	new inserted, results in different behavior in state 'Transparent', no return to normal transmission possible after detection of LOF	compliance to ETSI TS 102 080, corresponds to state NT1.10
3.	C/I-code LTD	new inserted	
4.	State 'Power Down'	renamed to state 'Deactivated'	for consistency reasons to 2B1Q
5.	State 'Data Transmission'	renamed to state 'Transparent'	
6.	Timer variables introduced	Name Duration	see Table 20

2.4.7.4 Inputs to the U-Transceiver

C/I-Commands

- AI** Activation Indication
 The downstream device issues this indication to announce that layer 1 is available. The U-transceiver in turn informs the LT side by transmitting U3.
- AR** Activation Request
 The U-transceiver is requested to start the activation process (if not already done) by sending the wake-up signal U1W.
- DI** Deactivation Indication
 This indication is used during a deactivation procedure to inform the U-transceiver that it may enter the 'Deactivated' (power-down) state.
- DT** Data Through Test Mode
 This unconditional command is used for test purposes only and forces the U-transceiver into state 'Transparent'.

Functional Description

- LTD LT Disable
This unconditional command forces the U-transceiver to state 'Test', where it transmits U0. No further action is initiated.
- RES Reset
Unconditional command which resets the U-transceiver.
- SSP Send Single Pulses
Unconditional command which requests the transmission of single pulses on the U-interface.
- TIM Timing
The U-transceiver is requested to enter state 'IOM Awaked'.

U-Interface Events

- U0 U0 detected
U0 is recognized after 120 symbols (1ms) with zero level in a row. Detection may last up to 2 ms.
- U2 U2 detected
The U-transceiver detects U2 if continuous binary 0's are found after descrambling and LOF = 0 for at least 8 subsequent U-frames. U2 is detected after 8 to 9 ms.
- U4H U4H detected
U4H is recognized, if the U-transceiver detects 16 subsequent binary 1's after descrambling.
- AWR Awake signal (U2W) detected
- AWT Awake signal (U1W) has been sent out
- LOF Loss of Framing on U-interface
- TxE Timer ended, the started timer has expired

Timers

The start of timers is indicated by TxS, the expiry by TxE. The following table shows which timers are used.

Table 20 Timers

Timer	Duration (ms)	Function	State
T05	0.5	C/I code recognition	Pend. Deactivation, Deactivating
T6	6	Supervises U1W repetition	Start Awakening Uk0

Functional Description

Table 20 Timers (cont'd)

Timer	Duration (ms)	Function	State
T12	12	Prevents the U-transceiver in state Synchronizing from immediate transition to state 'Pend. Deactivation' if U0 is detected	Synchronizing
T13	13	Supervises U2W repetition	Ack. sent / received Sending awake-ack.

2.4.7.5 Outputs of the U-Transceiver

Below the signals and indications are summarized that are issued on IOM[®]-2 (C/I indications) and on the U-interface (predefined U-signals).

C/I Indications

- AI** Activation Indication
 The U-transceiver has established transparency of transmission. The downstream device is requested to establish layer-1 functionality.
- AIL** Activation Indication Loop-back
 The U-transceiver has established transparency of transmission. The downstream device is requested to establish a loopback #2.
- AR** Activation Request
 The downstream device is requested to start the activation procedure.
- ARL** Activation Request Loop-back
 The U-transceiver has detected a loop-back 2 command in the M-channel and has established transparency of transmission in the direction IOM[®] to U-interface. The downstream device is requested to start the activation procedure and to establish a loopback #2.
- DC** Deactivation Confirmation
 Idle code on the IOM[®]-2 interface.
- DR** Deactivation Request
 The U-transceiver has detected a deactivation request command from the LT-side for a complete deactivation. The downstream device is requested to start the deactivation procedure.
- RSY** Resynchronizing Indication
 RSY informs the downstream device that the U-transceiver is not synchronous.

Functional Description

Signals on U-Interface

The signals U0, U1W, U1A, U1, U3, U5 and SP are transmitted on the U-interface. They are defined in [Table 25](#).

Signals on IOM[®]-2

The Data (B+B+D) is set to all '1's in all states besides the states listed in [Table 17](#).

Dependence of Outputs

The M-symbol output in states with valid M-symbol output its value is set according to [Table 21](#)

Table 21 M Symbol Output

RDS Error	not detected	detected
M Symbol Output	'0'	'+'

Table 22 Signal Output on Uk0 in State Test

Input	C/I-Code SSP applied	all other except C/I-Code 'DI'
Signal Output on Uk0	SP	U0

Table 23 C/I-Code Output

Loopback Command	SBC Synchronizing	Wait for Info U4H	Transparent
not received	AR	AR	AI
received	ARL	ARL	AIL

2.4.7.6 NT-States

In this section each state is described with its function.

Acknowledge Sent / Receive

After having sent the awake signal, the U-transceiver has received the acknowledge wake tone. If being awoken the U-transceiver has sent the acknowledge. In both cases the U-transceiver waits for possible repetition or time-out.

Functional Description

Awake Signal Sent

The NT has sent out the awake signal U1W and waits now for a response. If the LT does not react in time timer T6 expires and the NT repeats its wake-up call.

Deactivated

Only in “Deactivated” state the device may enter the power-down mode.

Deactivating

State Deactivating assures that the C/I-channel code DC is issued four times before entering the 'Deactivated' state.

IOM[®] Awaked

The U-transceiver is deactivated, but may not enter the power-down mode.

Loss of Framing

This state is entered on loss of framing (LOF). No signal is transmitted on the U-interface. A receiver-reset is performed by.

Note that there is no return to the 'Transparent' state that has been possible before in the former IEC-T based state machine.

Pending Deactivation

The U-transceiver has received U0. The U-transceiver remains at least 0.5ms in this state before it accepts DI.

SBC Synchronizing

The NT is now synchronized and indicates this by AR/ARL towards the downstream device. The NT waits for the acknowledge 'AI' from the downstream device.

Sending Awake-Ack.

On the receipt of the awake signal U2W the U-transceiver responds with the transmission of U1W.

Start Awakening Uk0

On the receipt of AR in the C/I-channel the U-transceiver sends the awake signal U1W to start an activation.

Synchronizing

After the successful awake procedure the U-transceiver trains its receiver coefficients until it is able to detect the signals U2.

Reset

In state 'Reset' a software-reset is performed.

Test

State "Test" is entered when the unconditional commands C/I=SSP is applied. The test signal SSP is issued as long as pin SSP is active or C/I=SSP is applied.

Transparent

The transmission line is fully activated. User data is transparently exchanged by U4/U5. Transparent state is entered in the case of a loopback 2. The downstream device is informed by C/I code AI that the transparent state has been reached

Note that in contrast to the former IEC-T state machine there is no resynchronization mechanism. Once loss of framing (LOF) has been detected a deactivation is initiated.

Wait for Info U4H

The NT is synchronized and waits now for the permission (U4H) to go to the 'Transparent' state.

2.4.8 U-Transceiver Interrupt Structure

The U-Interrupt Status register (ISTAU) contains the interrupt sources of the U-Transceiver (**Figure 36**). Each source can be masked by setting the corresponding bit of the U-Interrupt Mask register (MASKU) to '1'. Such masked interrupt status bits are not indicated when ISTAU is read and do not generate an interrupt request.

The ISTAU register is cleared on read access. The interrupt sources of the ISTAU register (UCIR, RDS, 1ms) need not be evaluated.

When at time t1 an interrupt source generates an interrupt, all further interrupts are collected. Reading the ISTAU register clears all interrupts set before t1, even if masked. All interrupts, which are flagged after t1 remain active. After the ISTAU read access, the next unmasked interrupt will generate the next interrupt at time t2. After t2 it is possible to reprogram the MASKU register, so that all interrupts, which arrived between t1 and t2 are accessible.

Functional Description

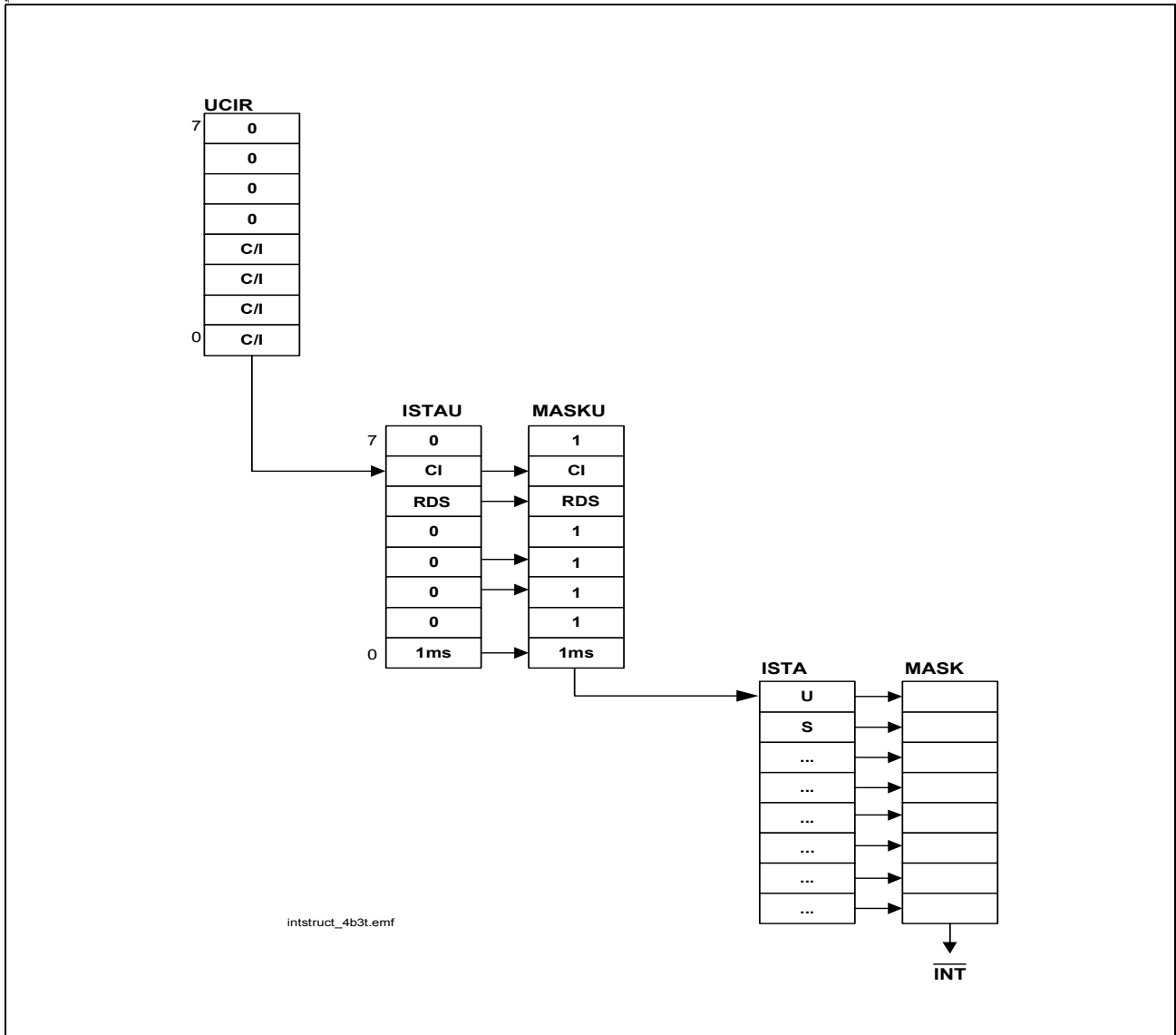

Figure 36 Interrupt Structure U-Transceiver

2.5 S-Transceiver

The S-Transceiver offers the NT and LT-S mode state machines described in the User's Manual V3.4 [8].

The S-transceiver lies in IOM[®]-2 channel 1 (default) and is configured and controlled via the registers described in [Chapter 4.5](#). The state machine is set to NT mode (default) but can be set to LT-S mode via register programming.

The TE mode (S-transceiver TE mode, U-transceiver disabled) is not supported.

2.5.1 Line Coding, Frame Structure

Line Coding

The following figure illustrates the line code. A binary ONE is represented by no line signal. Binary ZEROs are coded with alternating positive and negative pulses with two exceptions:

For the required frame structure a code violation is indicated by two consecutive pulses of the same polarity. These two pulses can be adjacent or separated by binary ONES. In bus configurations a binary ZERO always overwrites a binary ONE.

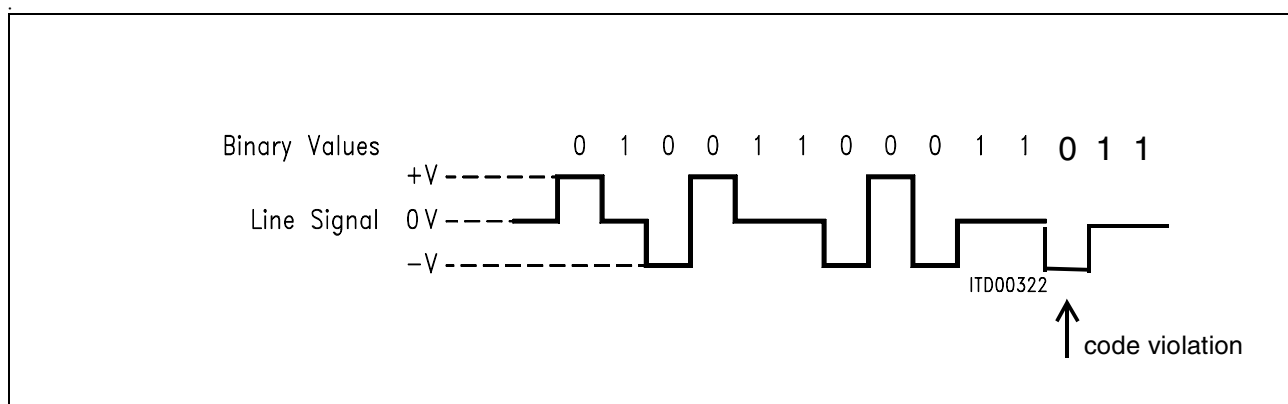

Figure 37 S/T-Interface Line Code

Frame Structure

Each S/T frame consists of 48 bits at a nominal bit rate of 192 kbit/s. For user data (B1+B2+D) the frame structure applies to a data rate of 144 kbit/s (see [Figure 37](#)).

In the direction TE → NT the frame is transmitted with a two bit offset. For details on the framing rules please refer to ITU I.430 section 6.3. The following figure illustrates the standard frame structure for both directions (NT → TE and TE → NT) with all framing and maintenance bits.

Functional Description

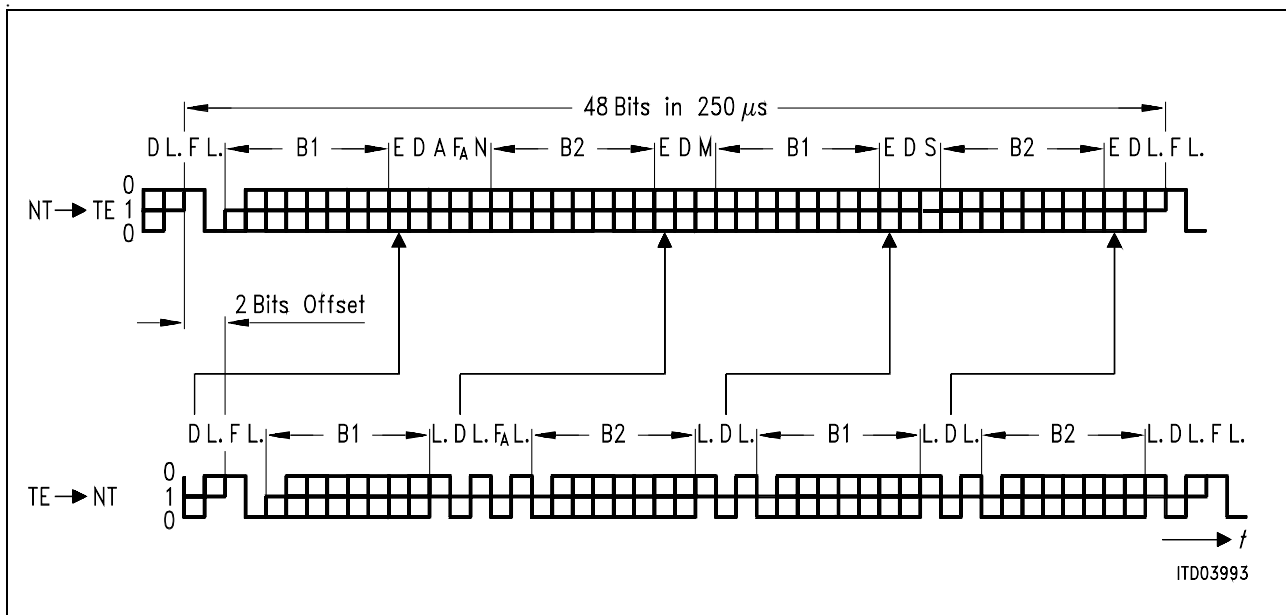

Figure 38 Frame Structure at Reference Points S and T (ITU I.430)

- F Framing Bit F = (0b) → identifies new frame (always positive pulse, always code violation)
- L. D.C. Balancing Bit L. = (0b) → number of binary ZEROs sent after the last L. bit was odd
- D D-Channel Data Bit Signaling data specified by user
- E D-Channel Echo Bit E = D → received E-bit is equal to transmitted D-bit
- F_A Auxiliary Framing Bit See section 6.3 in ITU I.430
- N $N = \overline{F_A}$
- B1 B1-Channel Data Bit User data
- B2 B2-Channel Data Bit User data
- A Activation Bit A = (0b) → INFO 2 transmitted
A = (1b) → INFO 4 transmitted
- S S-Channel Data Bit S₁ channel data (see note below)
- M Multiframing Bit M = (1b) → Start of new multi-frame

Note: The ITU I.430 standard specifies S1 - S5 for optional use.

Functional Description

2.5.2 S/Q Channels, Multiframe

According to ITU recommendation I.430 a multi-frame provides extra layer-1 capacity in the TE-to-NT direction through the use of an extra channel between the TE and NT (Q-channel). The Q bits are defined to be the bits in the F_A bit position.

In the NT-to-TE direction the S-channel bits are used for information transmission.

The S- and Q-channels are accessed via μC by reading/writing the SQR or SQX bits in the S/Q channel registers (SQRR, SQXR).

Table 24 shows the S and Q bit positions within the multi-frame.

Table 24 S/Q-Bit Position Identification and Multi-Frame Structure

Frame Number	NT-to-TE F_A Bit Position	NT-to-TE M Bit	NT-to-TE S Bit	TE-to-NT F_A Bit Position
1	ONE	ONE	S11	Q1
2	ZERO	ZERO	S21	ZERO
3	ZERO	ZERO	S31	ZERO
4	ZERO	ZERO	S41	ZERO
5	ZERO	ZERO	S51	ZERO
6	ONE	ZERO	S12	Q2
7	ZERO	ZERO	S22	ZERO
8	ZERO	ZERO	S32	ZERO
9	ZERO	ZERO	S42	ZERO
10	ZERO	ZERO	S52	ZERO
11	ONE	ZERO	S13	Q3
12	ZERO	ZERO	S23	ZERO
13	ZERO	ZERO	S33	ZERO
14	ZERO	ZERO	S43	ZERO
15	ZERO	ZERO	S53	ZERO
16	ONE	ZERO	S14	Q4
17	ZERO	ZERO	S24	ZERO
18	ZERO	ZERO	S34	ZERO
19	ZERO	ZERO	S44	ZERO
20	ZERO	ZERO	S54	ZERO
1	ONE	ONE	S11	Q1
2	ZERO	ZERO	S21	ZERO

The S-transceiver starts multiframe if SQXR1.MFEN is set.

After multi-frame synchronization has been established in the TE, the Q data will be inserted at the upstream (TE \rightarrow NT) F_A bit position by the TE in each 5th S/T frame, the

Functional Description

S data will be inserted at the downstream (NT → TE) S bit position in each 5th S/T frame (see [Table 24](#)). Access to S2-S5-channel is not supported.

Interrupt Handling for Multi-Framing

To trigger the microcontroller for a multi-frame access an interrupt can be generated once per multi-frame (SQW) or if the received Q-channel have changed (SQC). In both cases the microcontroller has access to the multiframe within the duration of one multiframe (5 ms).

The start of a multiframe can not be synchronized to an external signal.

2.5.3 Data Transfer between IOM[®]-2 and S₀

In the state G3 (Activated) or if the internal layer-1 statemachine is disabled and XINF of register S_CMD is programmed to '011' the B1, B2 and D bits are transferred transparently from the S/T to the IOM[®]-2 interface and vice versa. In all other states '1's are transmitted to the IOM[®]-2 interface.

Note: In intelligent NT or intelligent LT-S mode the D-channel access can be blocked by the IOM[®]-2 D-channel handler.

2.5.4 Loopback 2

C/I commands ARL and AIL close the analog loop as close to the S-interface as possible. ETSI refers to this loop under 'loopback 2'. ETSI requires, that B1, B2 and D channels have the same propagation delay when being looped back.

The D-channel Echo bit is set to bin. 0 during an analog loopback (i.e. loopback 2). The loop is transparent.

Note: After C/I-code AIL has been recognized by the S-transceiver, zeros are looped back in the B and D-channels (DU) for four frames.

2.5.5 Control of S-Transceiver / State Machine

The S-transceiver activation/ deactivation can be controlled by an internal statemachine via the IOM[®]-2 C/I-channel or by software via the μ C interface directly. In the default state the internal layer-1 statemachine of the S-transceiver is used. By setting the L1SW bit in the S_CONF0 register the internal statemachine can be disabled and the layer-1 transmit commands, which are normally generated by the internal statemachine can be written directly into the S_CMD register or the received status read out from the S_STA register, respectively. The S-transceiver layer-1 control flow is shown in [Figure 39](#).

Functional Description

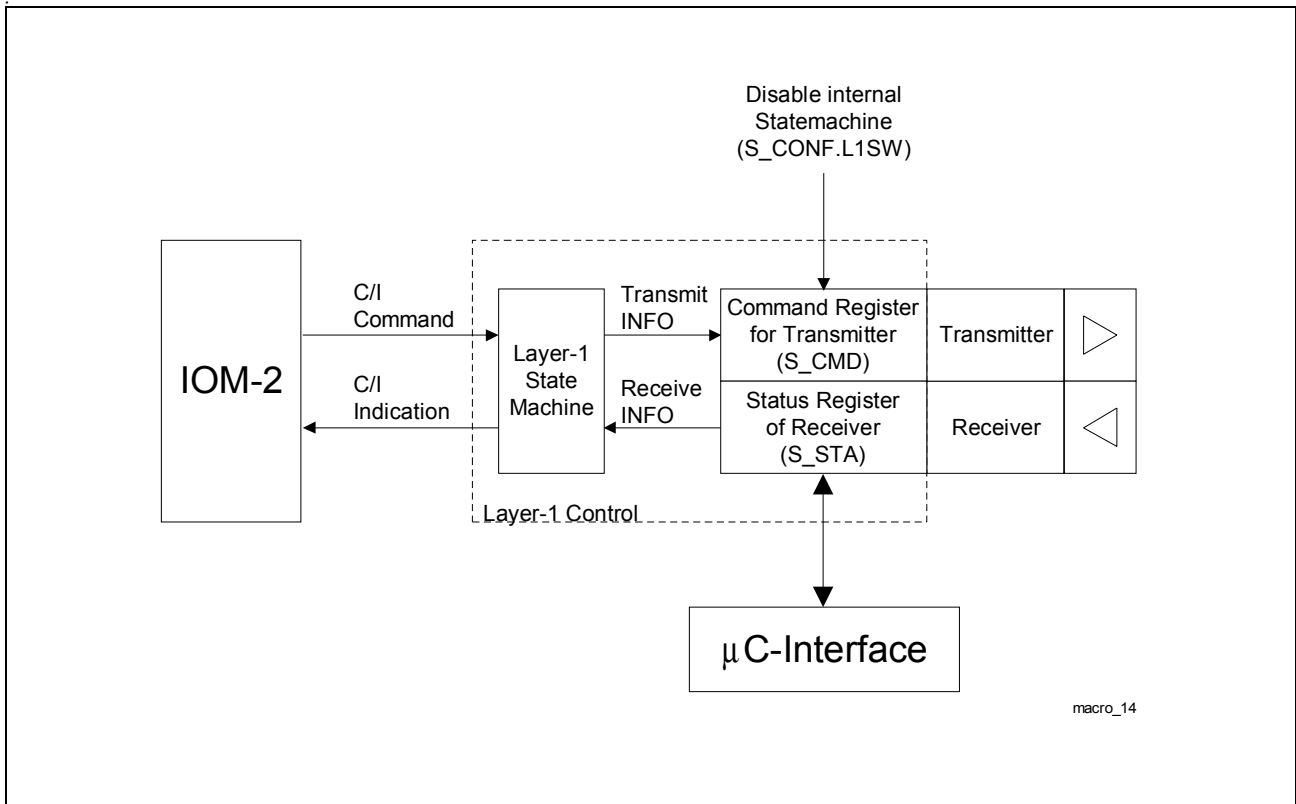

Figure 39 S-Transceiver Control

The state diagram notation is given in [Figure 40](#).

The information contained in the state diagrams are:

- state name
- Signal received from the line interface (INFO)
- Signal transmitted to the line interface (INFO)
- C/I code received (commands)
- C/I code transmitted (indications)
- transition criteria

The transition criteria are grouped into:

- C/I commands
- Signals received from the line interface (INFOs)
- Reset

Functional Description

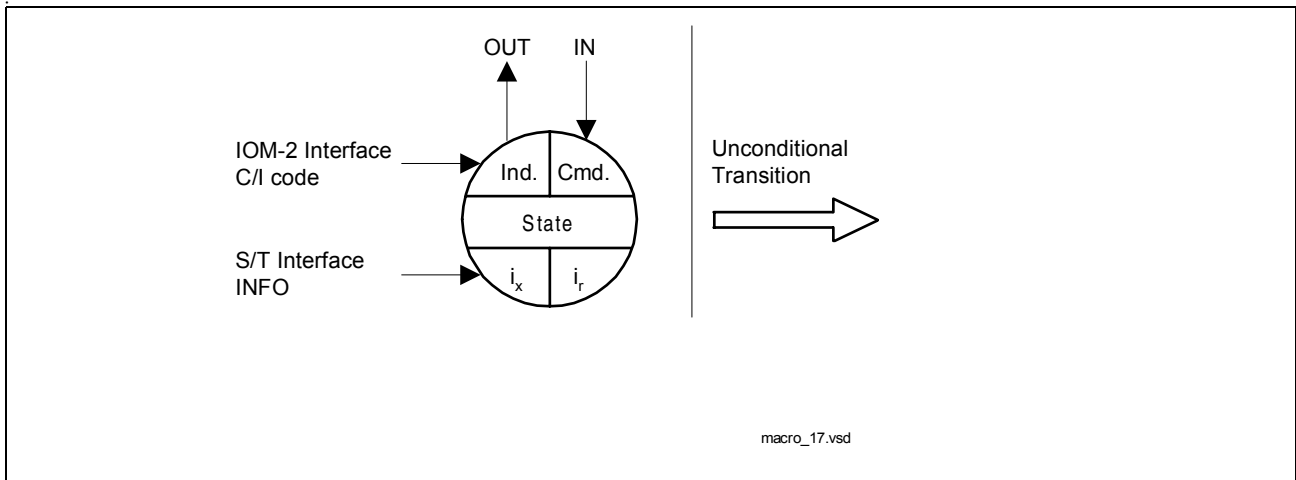

Figure 40 State Diagram Notation

As can be seen from the transition criteria, combinations of multiple conditions are possible as well. A “*” stands for a logical AND combination. And a “+” indicates a logical OR combination.

Test Signals

- 2 kHz Single Pulses (TM1)
One pulse with a width of one bit period per frame with alternating polarity.
- 96 kHz Continuous Pulses (TM2)
Continuous pulses with a pulse width of one bit period.

Note: The test signals TM1 and TM2 are invoked via C/I codes ‘TM1’ and ‘TM2’ according to [Chapter 2.5.5.1](#).

External Layer-1 Statemachine

Instead of using the integrated layer-1 statemachine it is also possible to implement the layer-1 statemachine completely in software.

The internal layer-1 statemachine can be disabled by setting the L1SW bit in the S_CONF0 register to '1'.

The transmitter is completely under control of the microcontroller via register S_CMD.

The status of the receiver is stored in register S_STA and has to be evaluated by the microcontroller. This register is updated continuously. If not masked a RIC interrupt is generated by any change of the register contents. The interrupt is cleared after a read access to this register.

Reset States

After an active signal on the reset pin \overline{RST} the S-transceiver state machine is in the reset state.

Functional Description

C/I Codes in Reset State

In the reset state the C/I code 0000 (TIM) is issued. This state is entered either after a hardware reset (\overline{RST}) or with the C/I code RES.

C/I Codes in Deactivated State

If the S-transceiver is in state 'Deactivated' and receives $\overline{i0}$, the C/I code 0000 (TIM) is issued until expiration of the 8 ms timer. Otherwise, the C/I code 1111 (DI) is issued.

2.5.5.1 C/I Codes

The table below presents all defined C/I0 codes. A command needs to be applied continuously until the desired action has been initiated. Indications are strictly state orientated. Refer to the state diagrams in the following sections for commands and indications applicable in various states.

Code	LT-S		NT	
	Cmd	Ind	Cmd	Ind
0 0 0 0	DR	TIM	DR	TIM
0 0 0 1	RES	–	RES	–
0 0 1 0	TM1	–	TM1	–
0 0 1 1	TM2	–	TM2	–
0 1 0 0	–	RSY	RSY	RSY
0 1 0 1	–	–	–	–
0 1 1 0	–	–	–	–
0 1 1 1	–	–	–	–
1 0 0 0	AR	AR	AR	AR
1 0 0 1	–	–	–	–
1 0 1 0	ARL	–	ARL	–
1 0 1 1	–	CVR	–	CVR
1 1 0 0	–	AI	AI	AI
1 1 0 1	–	–	–	–
1 1 1 0	–	–	AIL	–
1 1 1 1	DC	DI	DC	DI

Functional Description**Receive Infos on S/T**

I0	INFO 0 detected
$\bar{I}0$	Level detected (signal different to I0)
I3	INFO 3 detected
$\bar{I}3$	Any INFO other than INFO 3

Transmit Infos on S/T

I0	INFO 0
I2	INFO 2
I4	INFO 4
It	Send Single Pulses (TM1). Send Continuous Pulses (TM2).

2.5.5.2 State Machine NT Mode

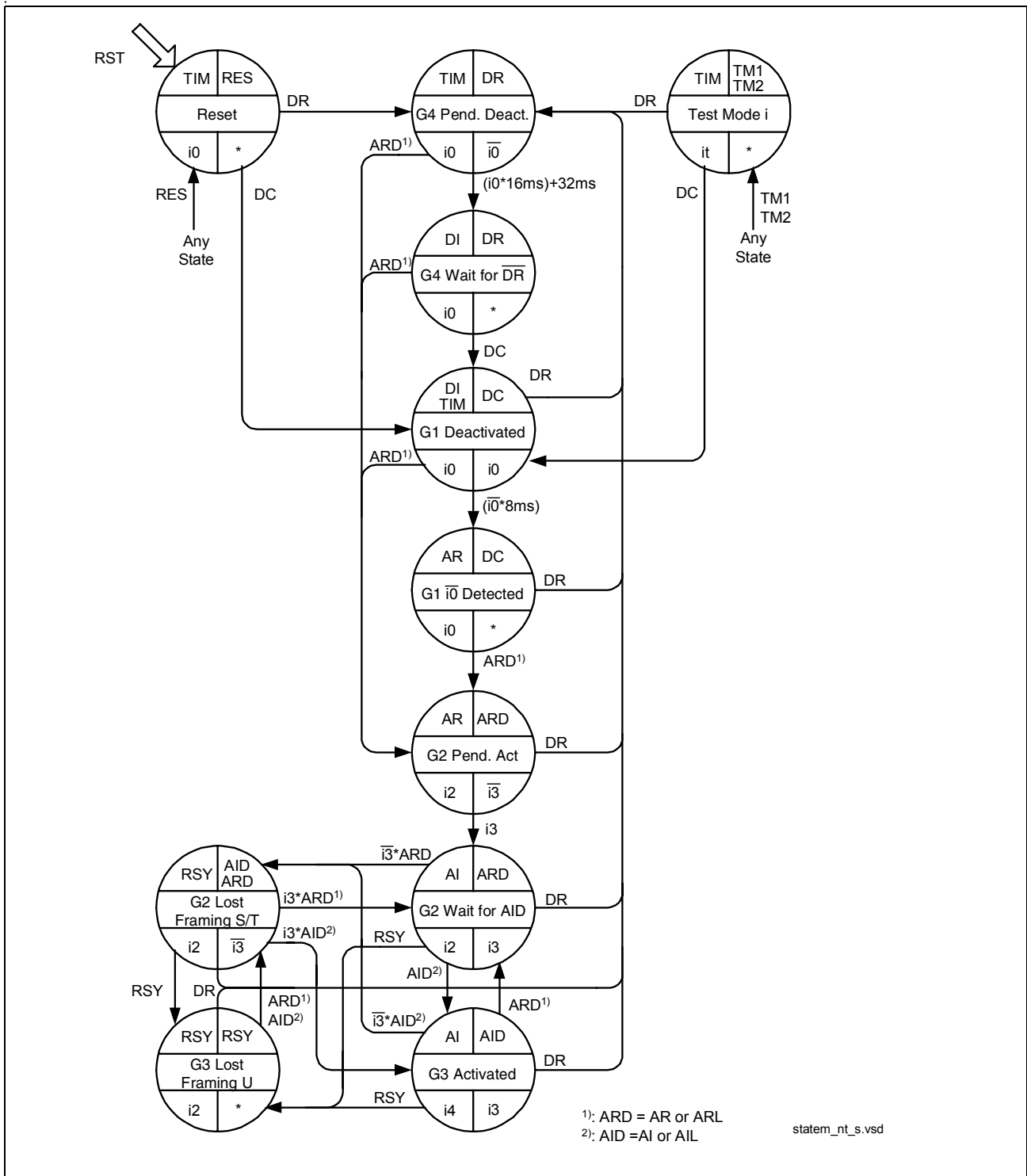

Figure 41 State Machine NT Mode

Note: State 'Test Mode' can be entered from any state except from state 'Test Mode' itself, i.e. C/I-code 'TMi' must not be followed by C/I-code 'TMj' directly.

Functional Description

G1 Deactivated

The S-transceiver is not transmitting. There is no signal detected on the S/T-interface, and no activation command is received in the C/I channel. Activation is possible from the S/T interface and from the IOM[®]-2 interface.

G1 $\overline{\text{I0}}$ Detected

An $\overline{\text{INFO 0}}$ is detected on the S/T-interface, translated to an “Activation Request” indication in the C/I channel. The S-transceiver is waiting for an AR command, which normally indicates that the transmission line upstream is synchronized.

G2 Pending Activation

As a result of the ARD command, an INFO 2 is sent on the S/T-interface. INFO 3 is not yet received. In case of ARL command, loop 2 is closed.

G2 wait for AID

INFO 3 was received, INFO 2 continues to be transmitted while the S-transceiver waits for a “switch-through” command AID from the device upstream.

G3 Activated

INFO 4 is sent on the S/T-interface as a result of the “switch through” command AID: the B and D-channels are transparent. On the command AIL, loop 2 is closed.

G2 Lost Framing S/T

This state is reached when the transceiver has lost synchronism in the state G3 activated.

G3 Lost Framing U

On receiving an RSY command which usually indicates that synchronization has been lost on the transmission line, the S-transceiver transmits INFO 2.

G4 Pending Deactivation

This state is triggered by a deactivation request DR, and is an unstable state. Indication DI (state “G4 wait for DR”) is issued by the transceiver when:

either INFO0 is received for a duration of 16 ms

or an internal timer of 32 ms expires.

Functional Description

G4 wait for \overline{DR}

Final state after a deactivation request. The S-transceiver remains in this state until DC is issued.

Unconditional States

Test Mode TM1

Send Single Pulses

Test Mode TM2

Send Continuous Pulses

C/I Commands

Command	Abbr.	Code	Remark
Deactivation Request	DR	0000	Deactivation Request. Initiates a complete deactivation by transmitting INFO 0.
Reset	RES	0001	Reset of state machine. Transmission of Info0. No reaction to incoming infos. RES is an unconditional command.
Send Single Pulses	TM1	0010	Send Single Pulses.
Send Continuous Pulses	TM2	0011	Send Continuous Pulses.
Receiver not Synchronous	RSY	0100	Receiver is not synchronous
Activation Request	AR	1000	Activation Request. This command is used to start an activation.
Activation Request Loop	ARL	1010	Activation request loop. The transceiver is requested to operate an analog loop-back close to the S/T-interface.
Activation Indication	AI	1100	Activation Indication. Synchronous receiver, i.e. activation completed.

Functional Description

Command	Abbr.	Code	Remark
Activation Indication Loop	AIL	1110	Activation Indication Loop
Deactivation Confirmation	DC	1111	Deactivation Confirmation. Transfers the transceiver into a deactivated state in which it can be activated from a terminal (detection of $\overline{\text{INFO 0}}$ enabled).

Indication	Abbr.	Code	Remark
Timing	TIM	0000	Interim indication during deactivation procedure.
Receiver not Synchronous	RSY	0100	Receiver is not synchronous.
Activation Request	AR	1000	$\overline{\text{INFO 0}}$ received from terminal. Activation proceeds.
Illegal Code Violation	CVR	1011	Illegal code violation received. This function has to be enabled in S_CONF0.EN_ICV.
Activation Indication	AI	1100	Synchronous receiver, i.e. activation completed.
Deactivation Indication	DI	1111	Timer (32 ms) expired or $\overline{\text{INFO 0}}$ received for a duration of 16 ms after deactivation request.

2.5.5.3 State Machine LT-S Mode

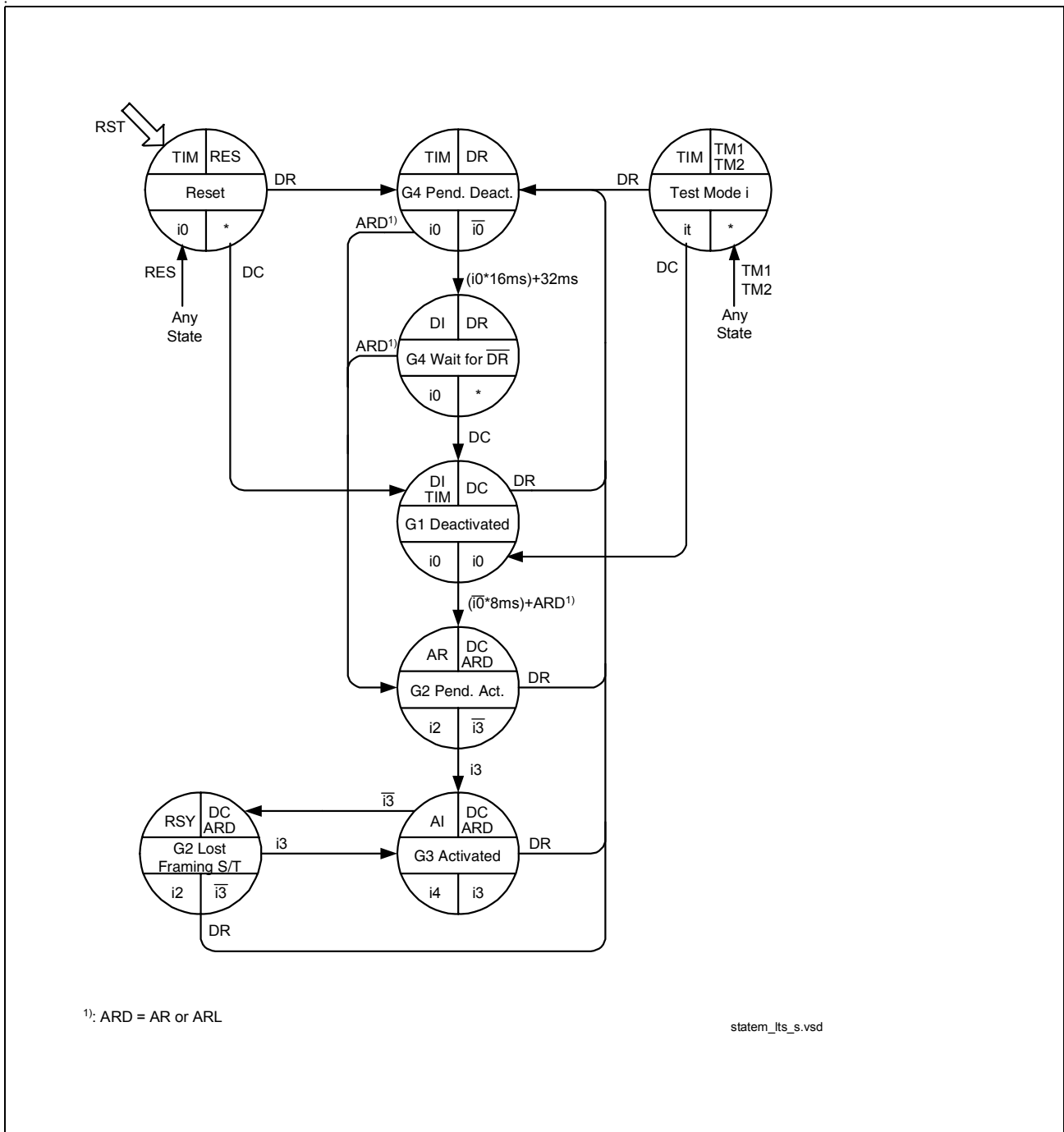

Figure 42 State Machine LT-S Mode

Note: State 'Test Mode' can be entered from any state except from state 'Test Mode' itself, i.e. C/I-code 'TMi' must not be followed by C/I-code 'TMj' directly.

Functional Description

G1 deactivated

The S-transceiver is not transmitting. There is no signal detected on the S/T-interface, and no activation command is received in the C/I channel. Activation is possible from the S/T interface and from the IOM[®]-2 interface.

G2 pending activation

As a result of an $\overline{\text{INFO 0}}$ detected on the S/T line or an ARD command, the S-transceiver begins transmitting INFO 2 and waits for reception of INFO 3. The timer to supervise reception of INFO 3 is to be implemented in software. In case of an ARL command, loop 2 is closed.

G3 activated

Normal state where INFO 4 is transmitted to the S/T-interface. The transceiver remains in this state as long as neither a deactivation nor a test mode is requested, nor the receiver loses synchronism.

When receiver synchronism is lost, INFO 2 is sent automatically. After reception of INFO 3, the transmitter keeps on sending INFO 4.

G2 lost framing

This state is reached when the S-transceiver has lost synchronism in the state G3 activated.

G4 pending deactivation

This state is triggered by a deactivation request DR. It is an unstable state: indication DI (state "G4 wait for DR.") is issued by the S-transceiver when:

either INFO0 is received for a duration of 16 ms,
or an internal timer of 32 ms expires.

G4 wait for $\overline{\text{DR}}$

Final state after a deactivation request. The transceiver remains in this state until DC is issued.

Unconditional States

Test mode - TM1

Single alternating pulses are sent on the S/T-interface.

Functional Description

Test mode - TM2

Continuous alternating pulses are sent on the S/T-interface.

Command	Abbr.	Code	Remark
Deactivation Request	DR	0000	DR - Deactivation Request. Initiates a complete deactivation by transmitting INFO 0.
Reset	RES	0001	Reset of state machine. Transmission of Info0. No reaction to incoming infos. RES is an unconditional command.
Send Single Pulses	TM1	0010	Send Single Pulses.
Send Continuous Pulses	TM2	0011	Send Continuous Pulses.
Activation Request	AR	1000	Activation Request. This command is used to start an activation.
Activation Request Loop	ARL	1010	Activation request loop. The transceiver is requested to operate an analog loop-back close to the S/T-interface.
Deactivation Confirmation	DC	1111	Deactivation Confirmation. Transfers the transceiver into a deactivated state in which it can be activated from a terminal (detection of $\overline{\text{INFO 0}}$ enabled).

Indication	Abbr.	Code	Remark
Timing	TIM	0000	Interim indication during activation procedure in G1.
Receiver not Synchronous	RSY	0100	Receiver is not synchronous
Activation Request	AR	1000	$\overline{\text{INFO 0}}$ received from terminal. Activation proceeds.
Illegal Code Ciolation	CVR	1011	Illegal code violation received. This function has to be enabled in S_CONF0.EN_ICV.
Activation Indication	AI	1100	Synchronous receiver, i.e. activation completed.
Deactivation Indication	DI	1111	Timer (32 ms) expired or INFO 0 received for a duration of 16 ms after deactivation request

2.5.6 S-Transceiver Enable / Disable

The layer-1 part of the S-transceiver can be enabled/disabled with the two bits S_CONF0.DIS_TR and S_CONF2.DIS_TX.

If DIS_TX='1' the transmit buffers are disabled. The receiver will monitor for incoming data in this configuration. By default the transmitter is disabled (DIS_TX = '1').

If the transceiver is disabled (DIS_TR = '1', DIS_TX = don't care) all layer-1 functions are disabled including the level detection circuit of the receiver. In this case the power consumption of the S-transceiver is reduced to a minimum.

2.5.7 Interrupt Structure S-Transceiver

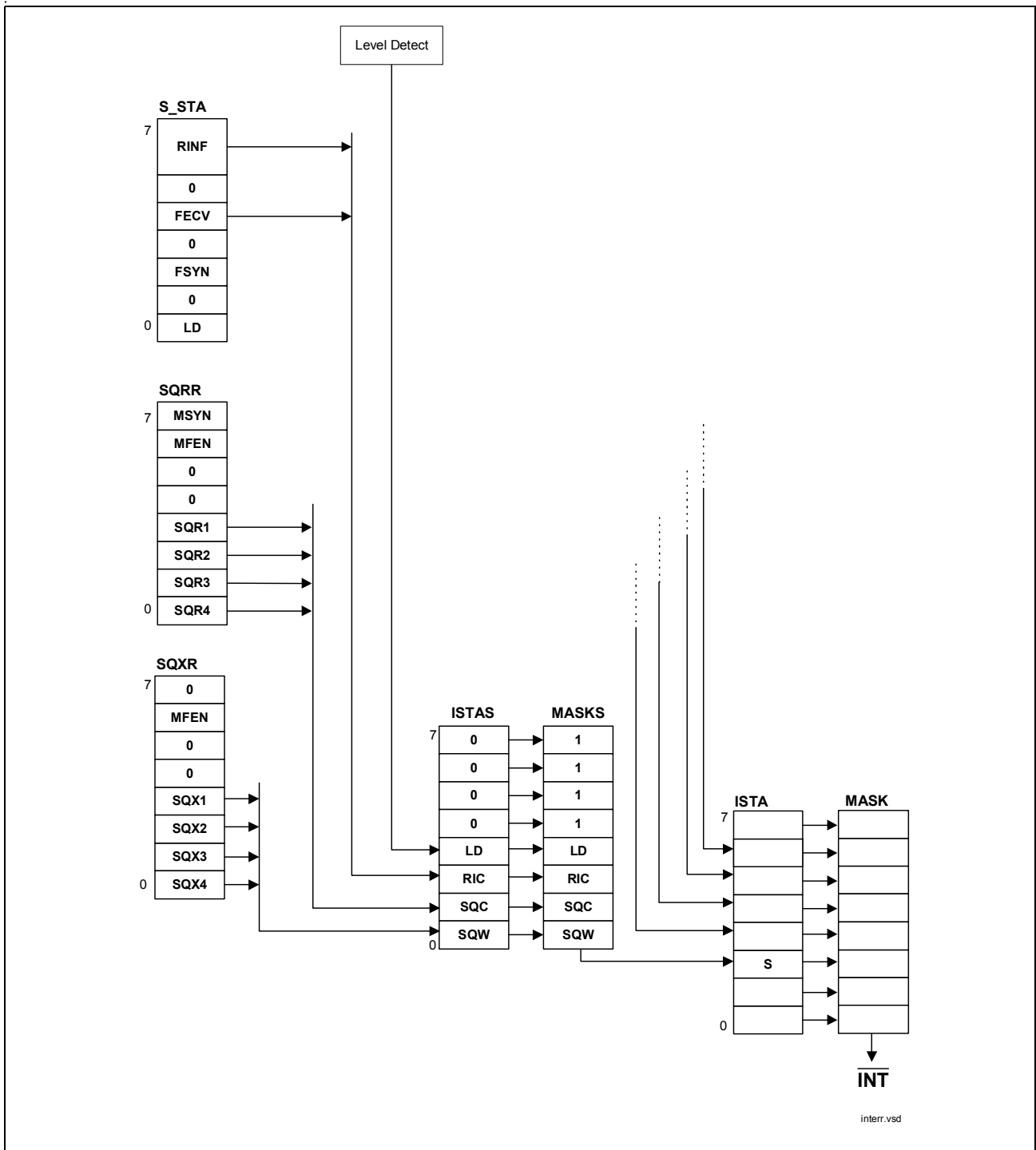

Figure 43 Interrupt Structure S-Transceiver

3 Operational Description

3.1 Layer 1 Activation/Deactivation

3.1.1 Generation of 4B3T Signal Elements

For control and monitoring purposes of the activation/deactivation progress the following signal elements are defined by TS 102 080 and FTZ 1 TR 220.

Table 25 4B3T Signal Elements

U0	No signal or deactivation signal that is used in both directions. Downstream, it requests the NT to deactivate. Upstream, the NT acknowledges by U0 that it is deactivated.
U1W, U2W	Awake or awake acknowledge signal used in the awake procedure of the U-interface.
U2	The LT sends U2 to enable the own echo canceller to adapt the coefficients. By the Barker code the NT at the other end is enabled to synchronize. The detection of U2 is used by the NT as a criterion for synchronization. The M-channel on U may be used to transfer loop commands.
U2A	While the NT-RP is synchronizing on the received signal, the LT-RP sends out U2A to enable its echo canceller to adapt the coefficients, but sending no Barker code it inhibits the NT to synchronize on the still asynchronous signal. Due to proceeding synchronization, the U-frame may jump from time to time. U2A can not be detected in the NT at the far end.
U1A	U1A is similar to U1 but without framing information. While the NT synchronizes on the received signal, it sends out U1A to enable its echo canceller to adapt its coefficients, but sends no Barker code to prevent the LT from synchronizing on the still asynchronous signal. Due to proceeding synchronization, the U-frame may jump from time to time. U1A can not be detected by the far-end LT.
U1	When synchronized, the NT sends the Barker code and the LT may synchronize itself. U1 indicates additionally that a terminal equipment has not yet activated. Upon receiving U1 the LT indicates the synchronized state by C/I 'UAI' to layer-2. Usually during activation, no U1 signal is detected in the LT because the TE is activated first and U1 changes to U3 before being detected. The M-channel on U may be used to transfer code error indications and 1 kbit/s transparent data.

Operational Description

Table 25 4B3T Signal Elements (cont'd)

U3	<p>U3 indicates that the whole link to the TE is synchronous in both directions. On detecting U3 the LT requests the NT by U4H to establish a fully transparent connection.</p> <p>The M-channel on U may be used to transfer code error indications and 1 kbit/s transparent data.</p>
U4H	<p>U4H requires the NT to go to the 'Transparent' state. On detecting U4H the NT stops sending signal U3 and informs the S-transceiver or a layer-2 device via the system interface.</p> <p>The M-channel on U may be used to transfer loop commands and 1 kbit/s transparent data.</p>
U4	<p>U4 transports operational data on B and D channels. The M-channel on U may be used to transfer loop commands and 1 kbit/s transparent data.</p>
U5	<p>U5 transports operational data on B and D channels. The M-channel on U may be used to transfer code error indications and 1 kbit/s transparent data.</p>
SP	<p>The T-SMINTI sends periodically single pulses once per millisecond on the U-interface. The test mode can be used for pulse mask measurements.</p>
LOF	<p>Loss of frame, generated by flywheel</p>

Table 26 Generation of the 4B3T Signal Elements

Upstream (NT to LT)	Downstream (LT to NT)		symbols (ternary)	sync word (ternary)	M symbol (ternary)	binary data before scrambling
U1W	U2W	Resulting in a tone of: Frequency: 7.5 kHz Duration: 2.13 ms when sending the wakeup tone is finished, signal AWT is set and ternary "0" is sent	16 times + ++++ +---- -----	n/a	n/a	n/a
U1A	U2A	scrambled binary data		0	0	0
U1	U2	scrambled binary data		yes	yes	0
U3		scrambled binary data		yes	yes	1

Operational Description

Table 26 Generation of the 4B3T Signal Elements (cont'd)

	U4H	Duration: 1 ms (warranted by state machine)		yes	yes	1
U5	U4	Binary data from the digital interface		yes	yes	BBD
U0	U0	Ternary continuous "0"	0	0	0	n/a
SP	SP	single pulses	once "+", 119 times "0" (repeatedly)	n/a	n/a	n/a

Table 27 S/T-Interface Signals

Signals from NT to TE		Signals from TE to NT	
INFO 0	No signal.	INFO 0	No signal.
		INFO 1	A continuous signal with the following pattern: Positive ZERO, negative ZERO, six ONES.
INFO 2	Frame with all bits of B, D, and D-echo channels set to binary ZERO. Bit A set to binary ZERO. N and L bits set according to the normal coding rules.		
		INFO 3	Synchronized frames with operational data on B and D-channels.
INFO 4	Frames with operational data on B, D, and D-echo channels. Bit A set to binary ONE.		

3.1.2 Complete Activation Initiated by Exchange

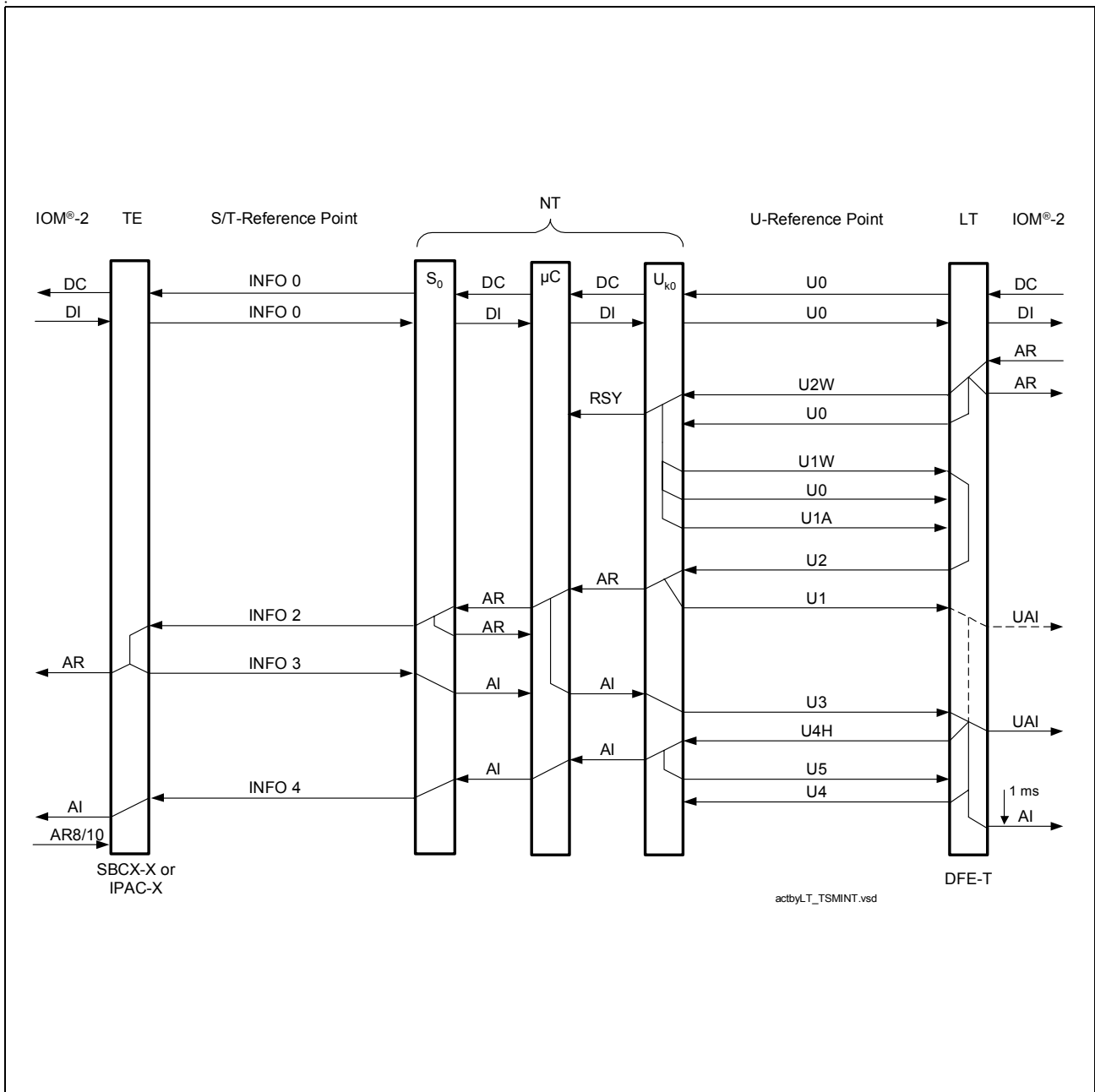

Figure 44 Activation Initiated by Exchange

Note: The LT starts issuing signal U2 before the NT starts issuing U1A. This chronological order is not displayed for clarification.

3.1.3 Complete Activation Initiated by TE

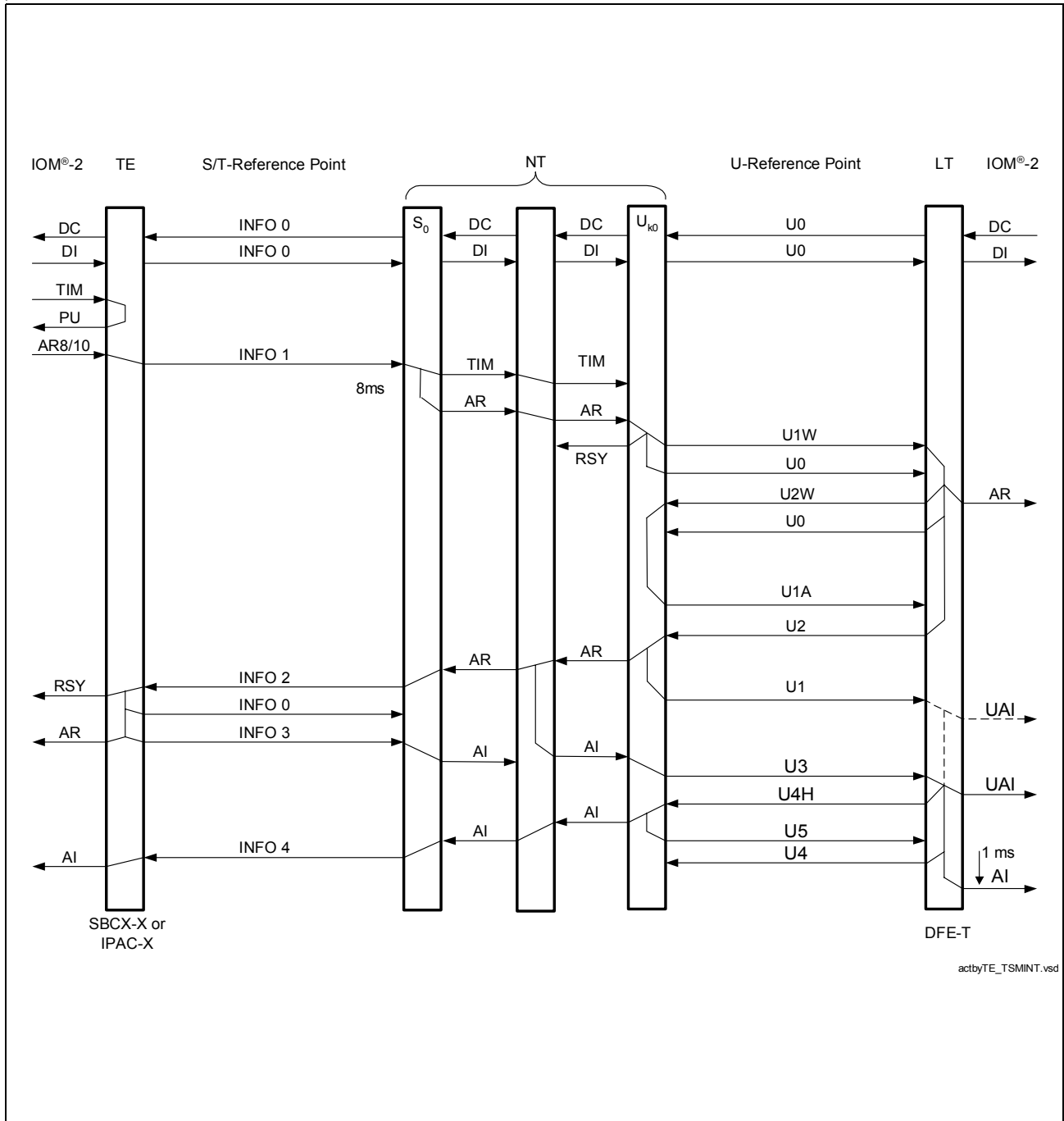

Figure 45 Activation Initiated by TE

Note: The LT starts issuing signal U2 before the NT starts issuing U1A. This chronological order is not displayed for clarification.

3.1.4 Complete Activation Initiated by NT

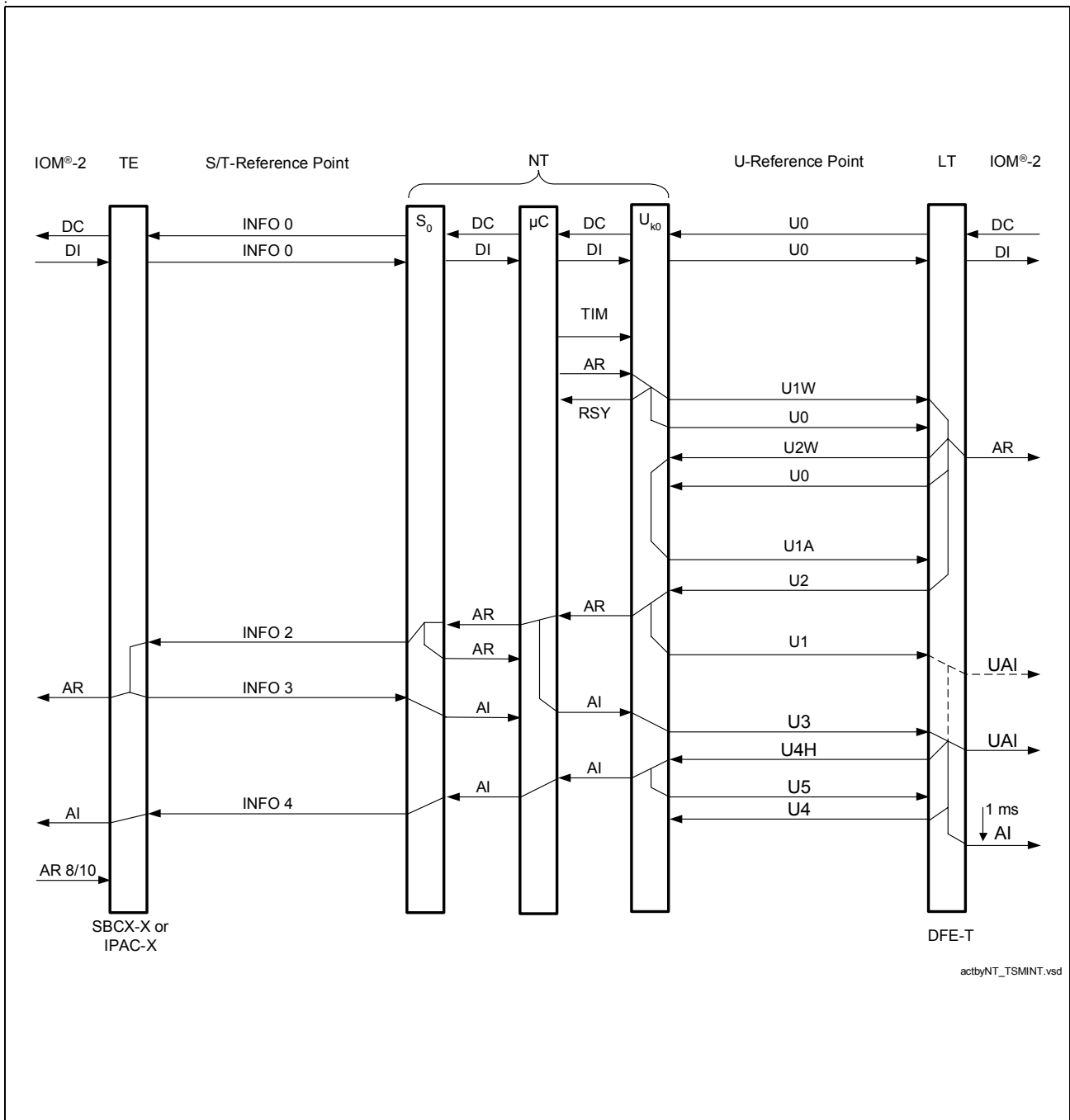

Figure 46 Activation Initiated by NT

Note: The LT starts issuing signal U2 before the NT starts issuing U1A. This chronological order is not displayed for clarification.

3.1.5 Complete Deactivation

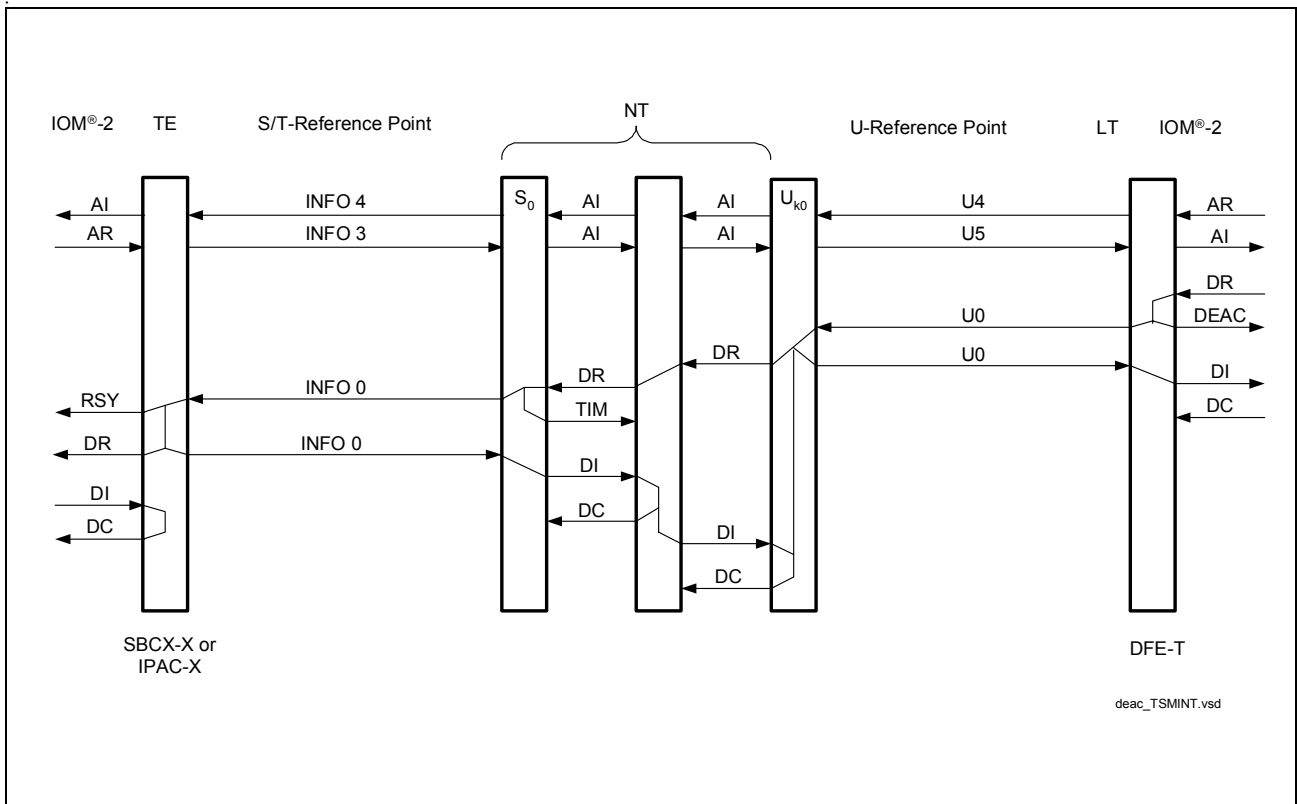

Figure 47 Complete Deactivation

3.1.6 Loop 2

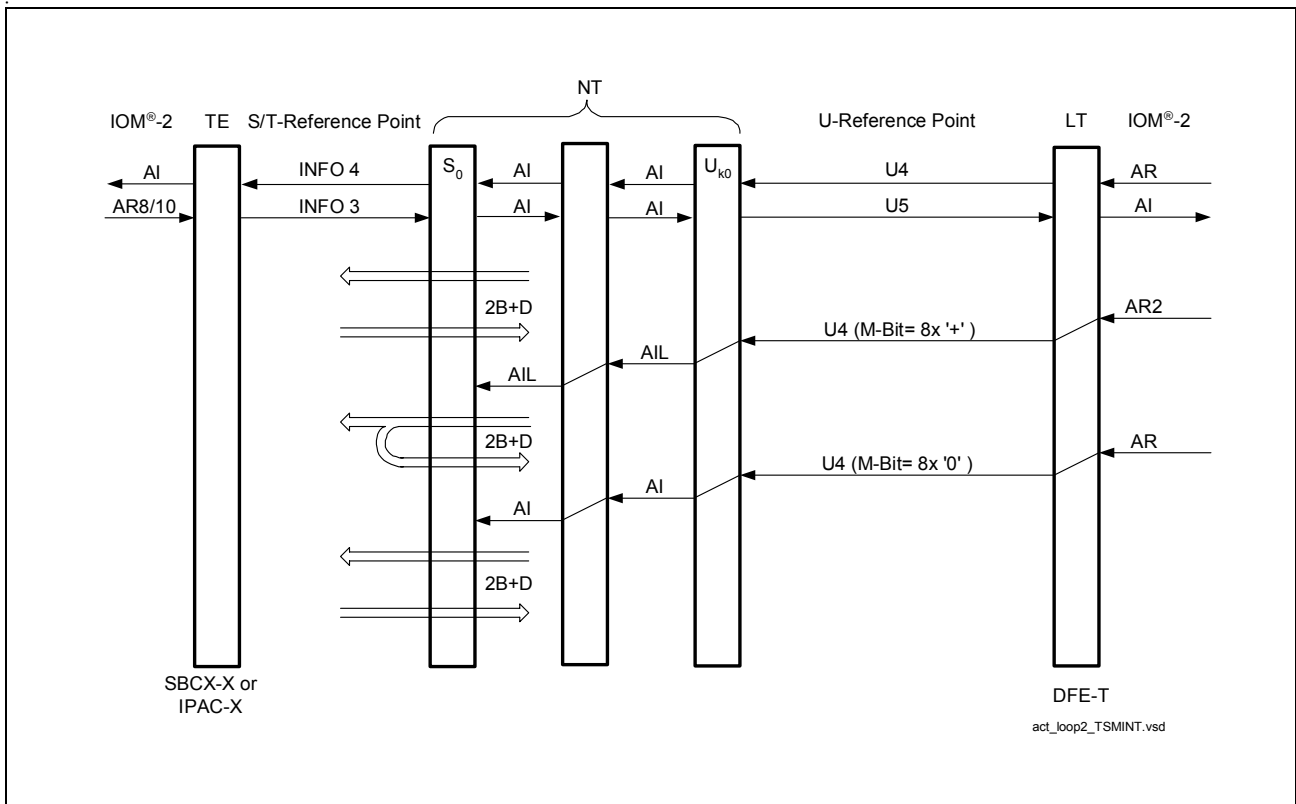

Figure 48 Loop 2

Note: Closing/resolving loop 2 may provoke the S-transceiver to resynchronize. In this case, the following C/I-codes are exchanged immediately on reception of AIL/AI, respectively: DU: 'RSY', DU: 'AI', DD: 'AIL'/'AI'.

3.2 Layer 1 Loopbacks

Test loopbacks are specified by the national PTTs in order to facilitate the location of defect systems. Four different loopbacks are defined. The position of each loopback is illustrated in **Figure 49**.

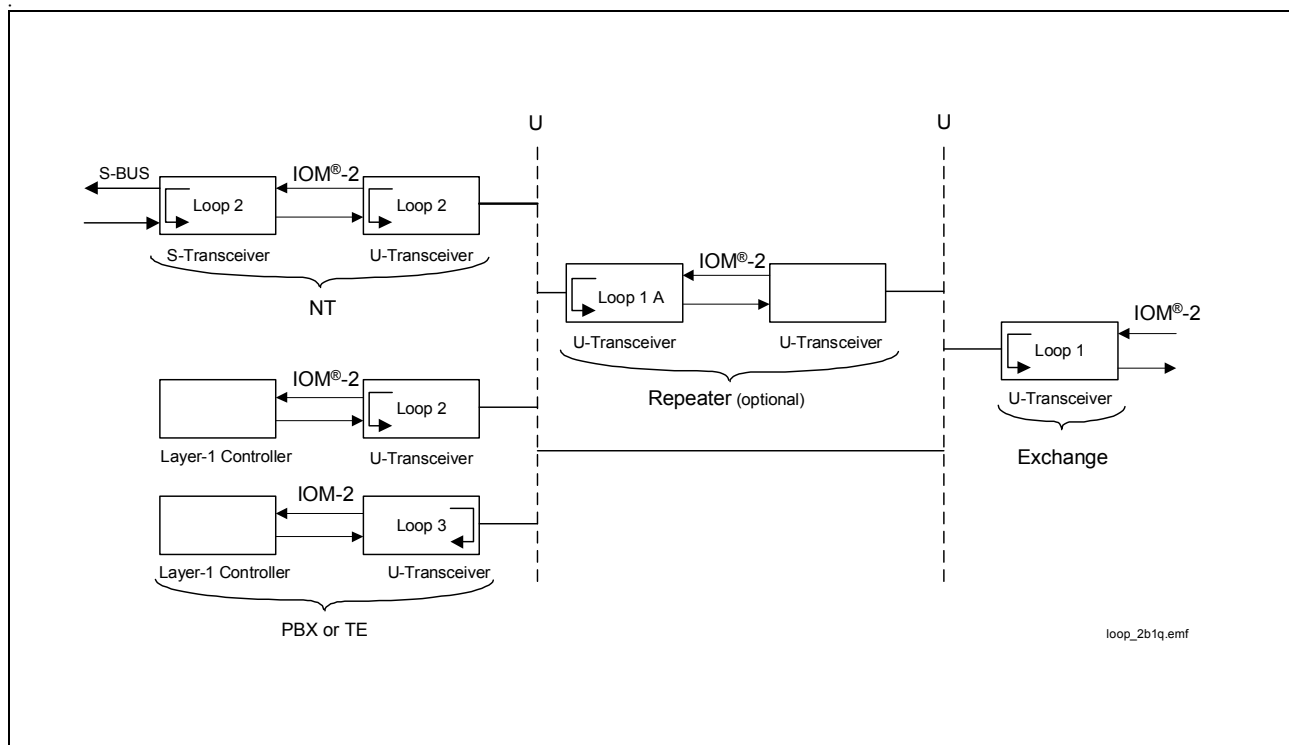

Figure 49 Test Loopbacks

Loopbacks #1, #1A and #2 are controlled by the exchange. Loopback #3 is controlled locally on the remote side. All four loopback types are transparent. This means all bits that are looped back will also be passed onwards in the normal manner. Only the data looped back internally is processed; signals on the receive pins are ignored. The propagation delay of actually looped B and D channels data must be identical in all loopbacks.

Besides the remote controlled loopback stimulation via the M channel, the T-SMINT®I features also direct loopback control via its register set.

3.2.1 Analog Loop-Back S-Transceiver

The T-SMINT®I provides test and diagnostic functions for the S/T interface:

The **internal local loop** (internal Loop A) is activated by a C/I command ARL or by setting the bit LP_A (Loop Analog) in the S_CMD register if the layer-1 statemachine is disabled.

The transmit data of the transmitter is looped back internally to the receiver. The data of the IOM®-2 input B- and D-channels are looped back to the output B- and D-channels.

Operational Description

The S/T interface level detector is enabled, i.e. if a level is detected this will be reported by the Resynchronization Indication (RSY) but the loop function is not affected. Depending on the DIS_TX bit in the S_CONF2 register the internal local loop can be transparent or non transparent to the S/T line.

The **external local loop (external Loop A)** is activated in the same way as the internal local loop described above. Additionally the EXLP bit in the S_CONF0 register has to be programmed and the loop has to be closed externally as described in [Figure 50](#). The S/T interface level detector is disabled.

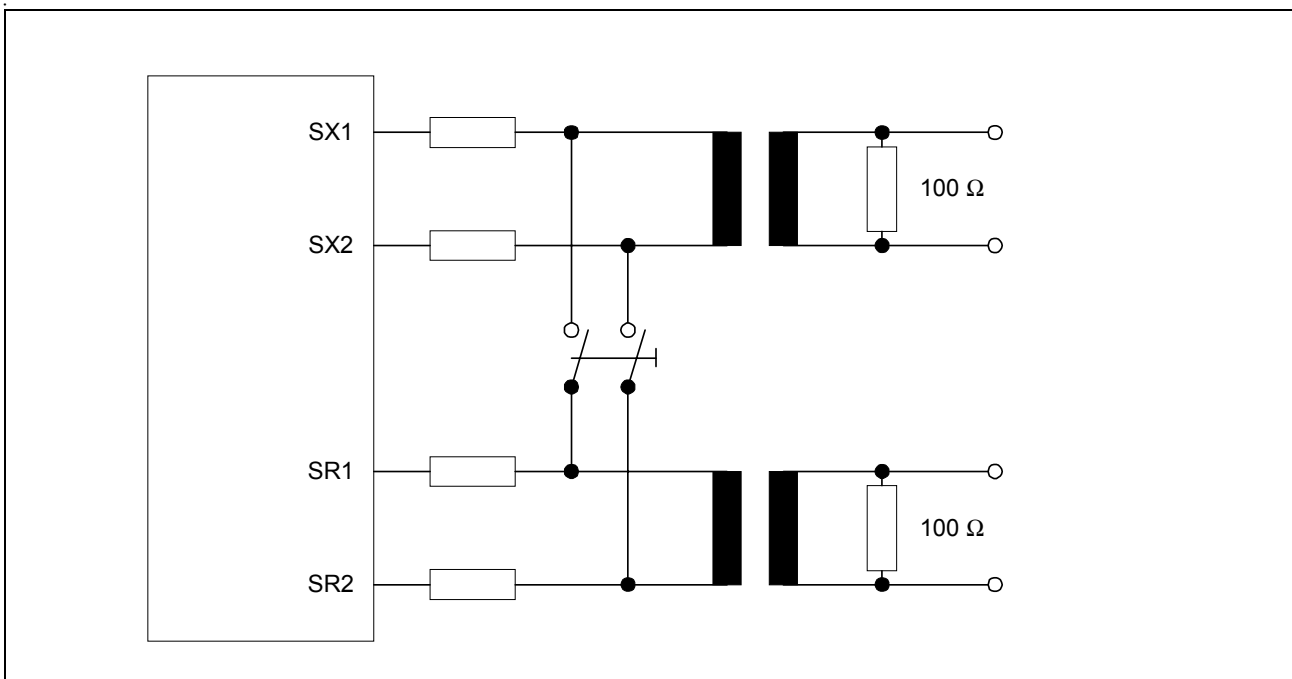

Figure 50 External Loop at the S/T-Interface

3.2.2 Loopback No.2

For loopback #2 several alternatives exist. Both the type of loopback and the location may vary. The following loopback types belong to the loopback-#2 category:

- complete loopback (B1,B2,D), in the U-transceiver
- complete loopback (B1,B2,D), in a downstream device
- B1-channel loopback, always performed in the U-transceiver
- B2-channel loopback, always performed in the U-transceiver

All loop variations performed by the U-transceiver are closed as near to the internal IOM[®]-2 interface as possible.

Normally loopback #2 is controlled by the exchange. The maintenance channel is used for this purpose.

3.2.2.1 Complete Loopback

When receiving the request for a complete loopback, the U transceiver passes it on to the downstream device, e.g. the S-bus transceiver. This is achieved by issuing the C/I-code AIL in the “Transparent” state or C/I = ARL in states different than “Transparent”

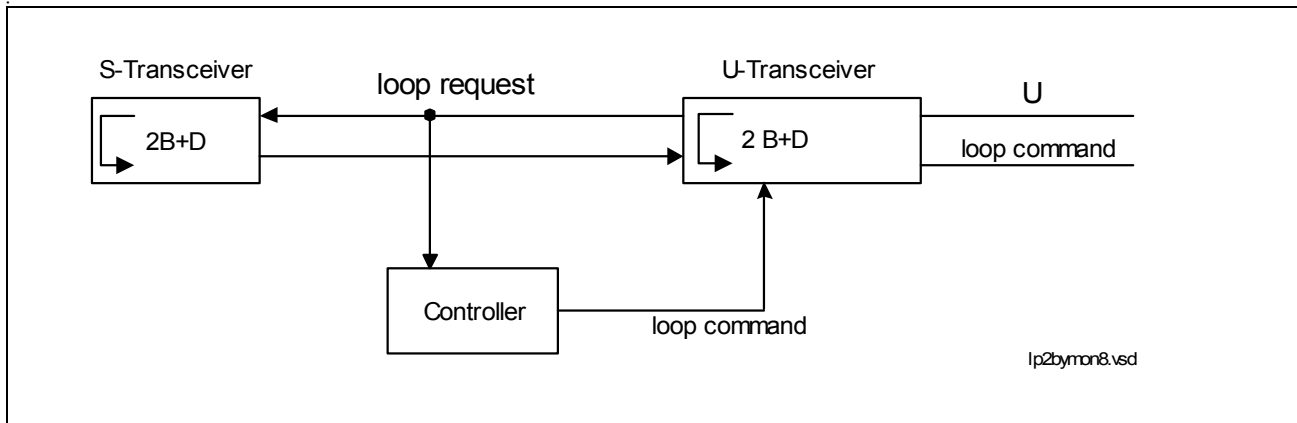

Figure 51 Complete Loopback Options in NT-Mode

The complete loopback is either opened under control of the exchange via the maintenance channel or locally controlled via the μ C. No reset is required for loopback #2. The line stays active and is ready for data transmission.

3.2.2.2 Loopback No.2 - Single Channel Loopbacks

Single channel loopbacks are always performed directly in the U-Transceiver. No difference between the B1-channel and the B2-channel loopback control procedure exists.

3.2.3 Local Loopbacks Featured By the LOOP Register

Besides the standardized remote loopbacks the U-transceiver features additional local loopbacks for enhanced test and debugging facilities. The local loopbacks that are featured by register LOOP are shown in [Figure 52](#). They are closed in the U-transceiver itself and can be activated regardless of the current operational status.

By the LOOP register it can be configured whether the loopback is closed only for the B1 and/or B2 or for 2B+D channels and whether the loopback is closed towards the internal IOM[®]-2 interface or towards the U-Interface.

By default the loopbacks are set to transparent mode. In transparent mode the data is both passed on and looped back. In non-transparent mode the data is not forwarded but substituted by 1s (idle code).

Operational Description

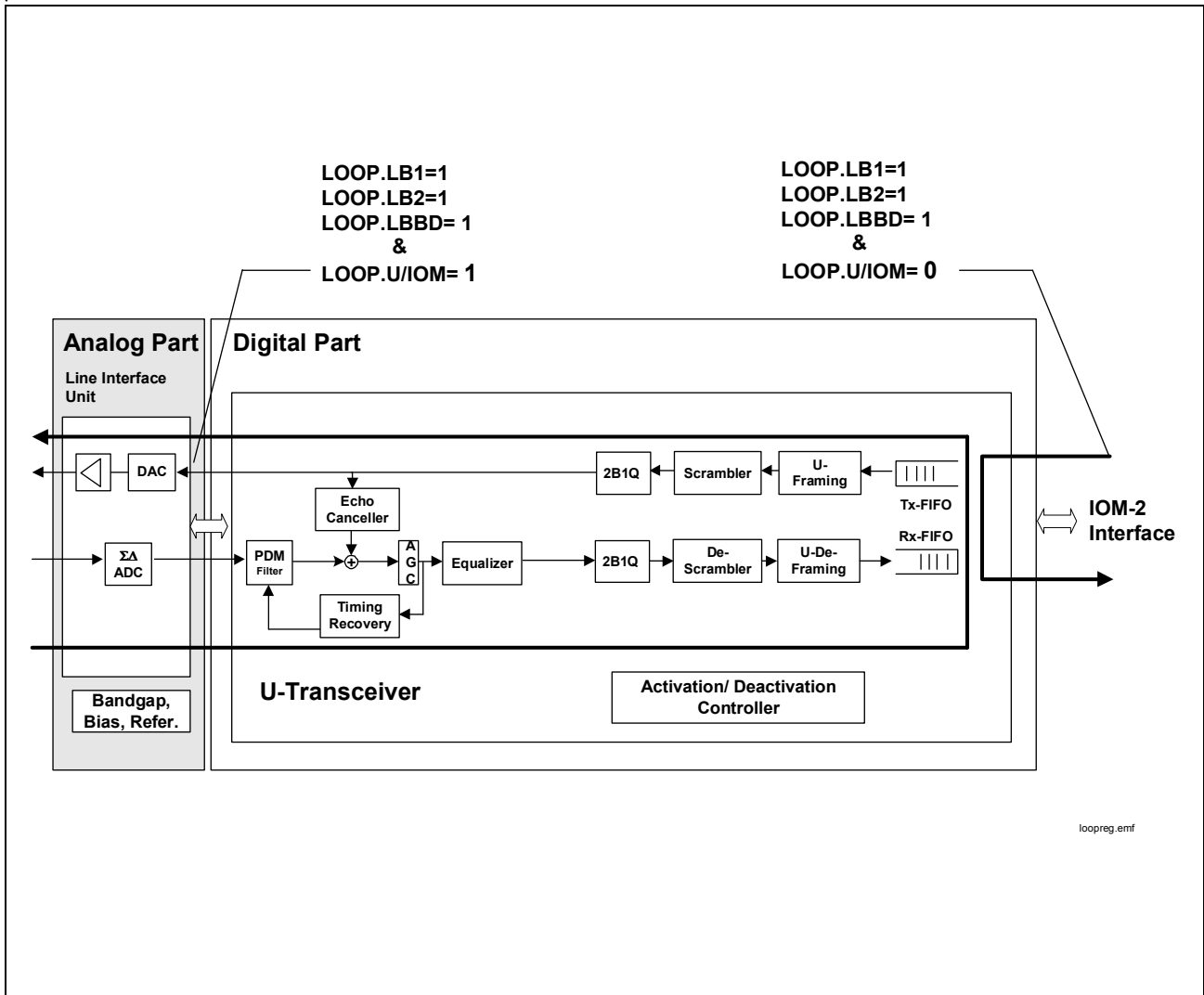

loopreg.emf

Figure 52 Loopbacks Featured by Register LOOP

3.3 External Circuitry

3.3.1 Power Supply Blocking Recommendation

The following blocking circuitry is suggested.

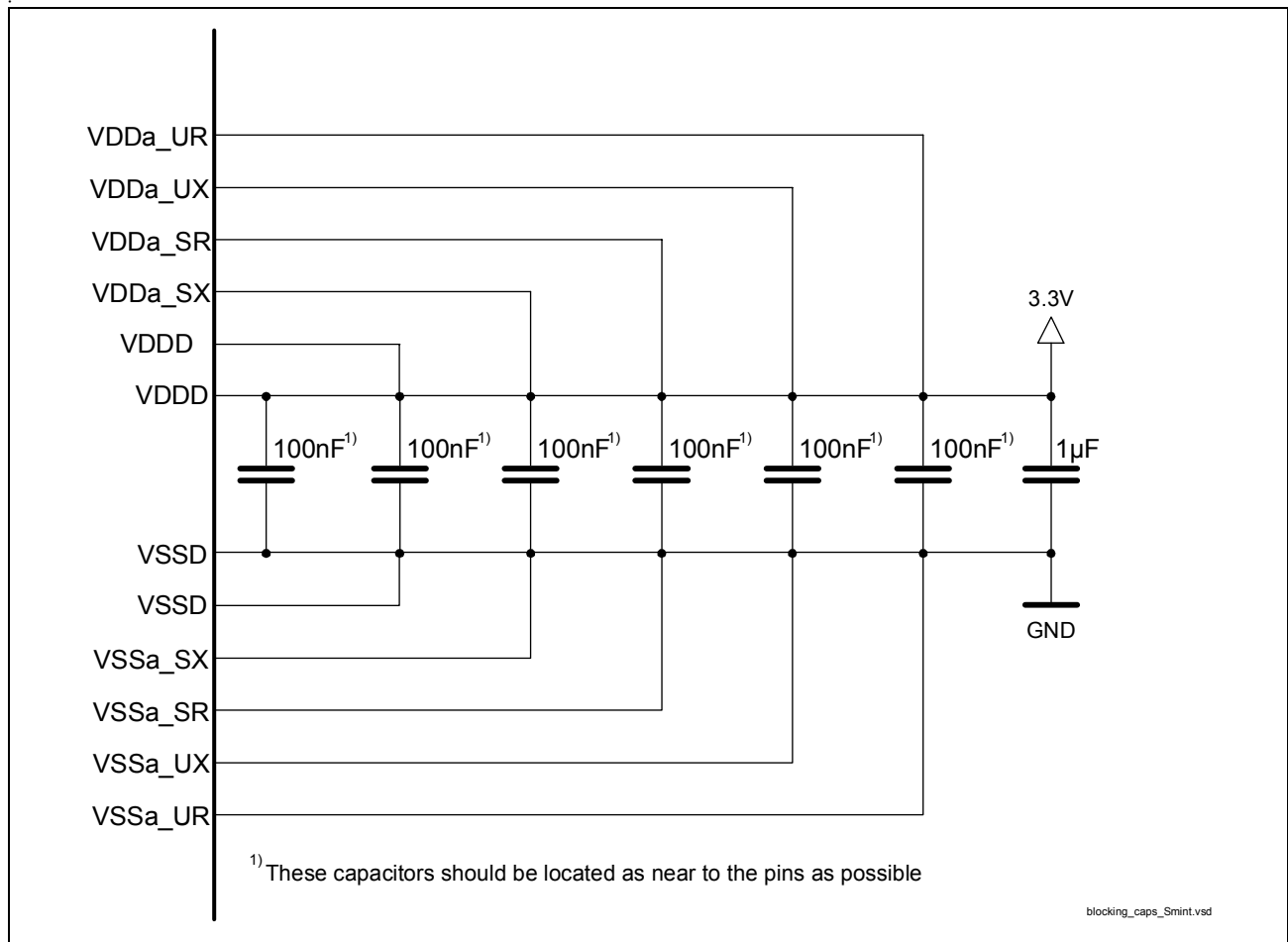

Figure 53 Power Supply Blocking

3.3.2 U-Transceiver

The T-SMINTI is connected to the twisted pair via a transformer. [Figure 54](#) shows the recommended external circuitry with external hybrid. The recommended protection circuitry is not displayed.

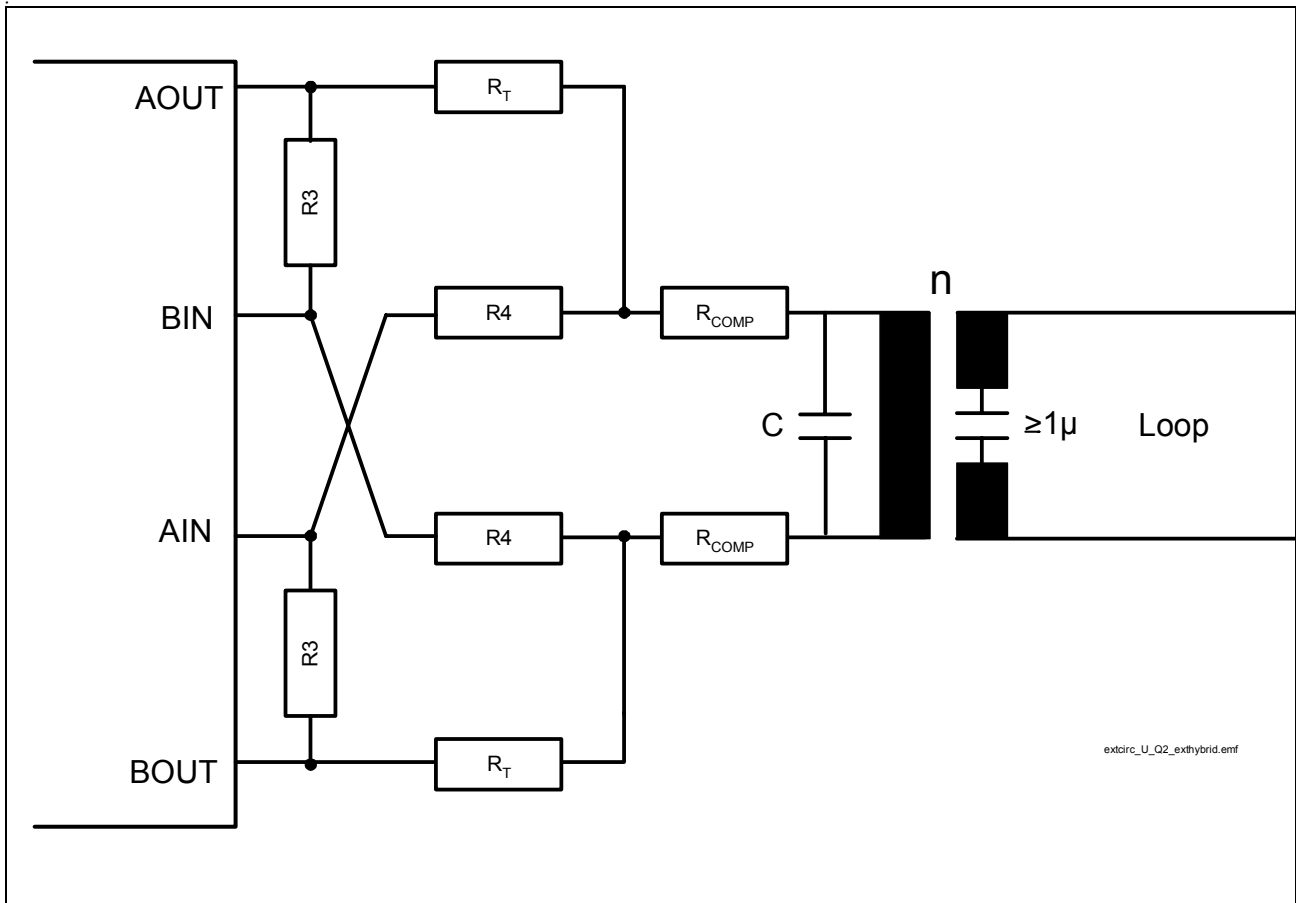

Figure 54 External Circuitry U-Transceiver with External Hybrid

U-Transformer Parameters

The following table lists parameters of typical U-transformers.

Table 28 U-Transformer Parameters

U-Transformer Parameters	Symbol	Value	Unit
U-Transformer ratio; Device side : Line side	n	1 : 1.6	
Main inductanc of windings on the line side	L _H	7.5	mH
Leakage inductance of windings on the line side	L _S	120	μH
Coupling capacitance between the windings on the device side and the windings on the line side	C _K	30	pF
DC resistance of the windings on device side	R _B	0.9	Ω
DC resistance of the windings on line side	R _L	1.8	Ω

Resistors of the External Hybrid R3, R4 and R_T

$$R_3 = 1.75 \text{ k}\Omega$$

$$R_4 = 1.0 \text{ k}\Omega$$

$$R_T = 25 \text{ }\Omega$$

Resistors R_{COMP} / R_T

- Optional use of trafos with non negligible resistance R_B, R_L requires compensation resistors R_{COMP} depending on R_B and R_L:

$$n^2 \times (2R_{COMP} + R_B) + R_L = 20\Omega \quad (1)$$

- Compliance with Return Loss Measurements:

$$n^2 \times (2R_{COMP} + 2R_T + R_{out} + R_B) + R_L = 150\Omega \quad (2)$$

R_B, R_L : see [Table 28](#)

R_{OUT} : see [Table 35](#)

15nF Capacitor

To achieve optimum performance the 15nF capacitor should be MKT. A Ceramic capacitor is not recommended.

Tolerances

- R_s: 1%
- C = 15nF: 10-20%
- L_H = 7.5mH: 10%

3.3.3 S-Transceiver

In order to comply to the physical requirements of ITU recommendation I.430 and considering the national requirements concerning overvoltage protection and electromagnetic compatibility (EMC), the S-transceiver needs some additional circuitry.

S-Transformer Parameters

The following **Table 29** lists parameters of a typical S-transformer:

Table 29 S-Transformer Parameters

Transformer Parameters	Symbol	Value	Unit
Transformer ratio; Device side : Line side	n	2 : 1	
Main inductance of windings on the line side	L _H	typ. 30	mH
Leakage inductance of windings on the line side	L _S	typ. <3	μH
Coupling capacitance between the windings on the device side and the windings on the line side	C _K	typ. <100	pF
DC resistance of the windings on device side	R _B	typ. 2.4	Ω
DC resistance of the windings on line side	R _L	typ. 1.4	Ω

Transmitter

The **transmitter** requires external resistors $R_{stx} = 47\Omega$ in order to adjust the output voltage to the pulse mask (nominal 750 mV according to ITU I.430, to be tested with the test mode “TM1”) on the one hand and in order to meet the output impedance of minimum 20 Ω on the other hand (to be tested with the testmode ‘Continuous Pulses’) on the other hand.

Note: The resistance of the S-transformer must be taken into account when dimensioning the external resistors R_{stx} . If the transmit path contains additional components (e.g. a choke), then the resistance of these additional components must be taken into account, too.

Operational Description

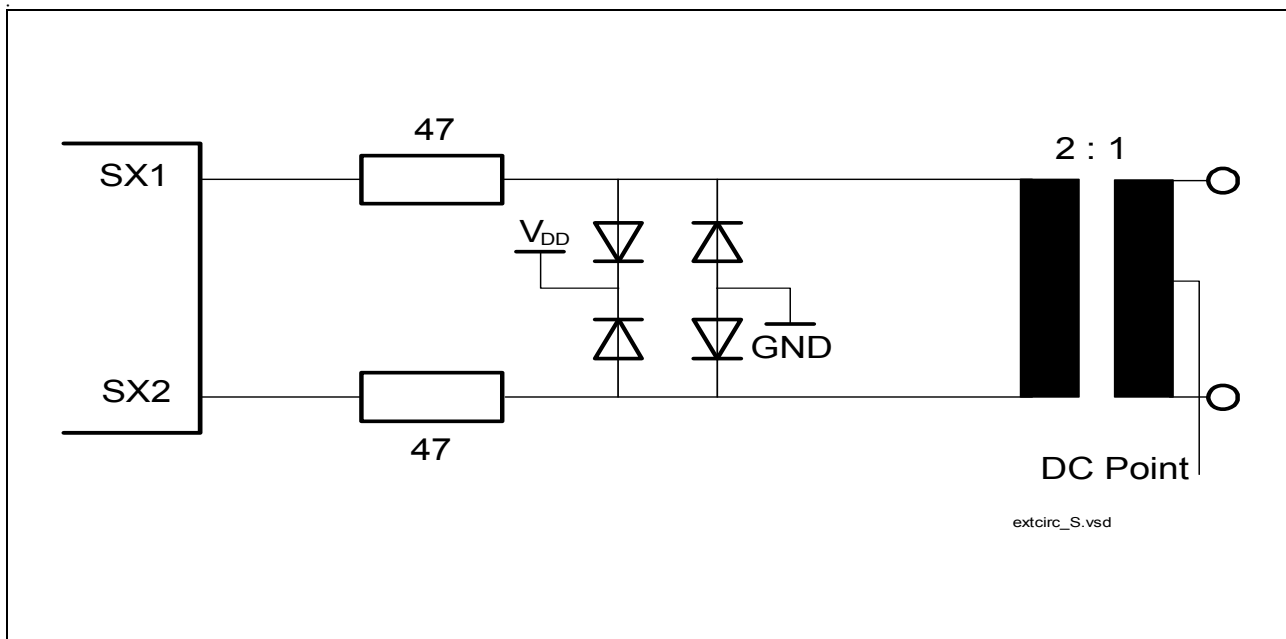

Figure 55 External Circuitry S-Interface Transmitter

Receiver

The **receiver** of the S-transceiver is symmetrical. 10 kΩ overall resistance are recommended in each receive path. It is preferable to split the resistance into two resistors for each line. This allows to place a high resistance between the transformer and the diode protection circuit (required to pass 96 kHz input impedance test of ITU I.430 [6] and ETS 300012-1). The remaining resistance (1.8 kΩ) protects the S-transceiver itself from input current peaks.

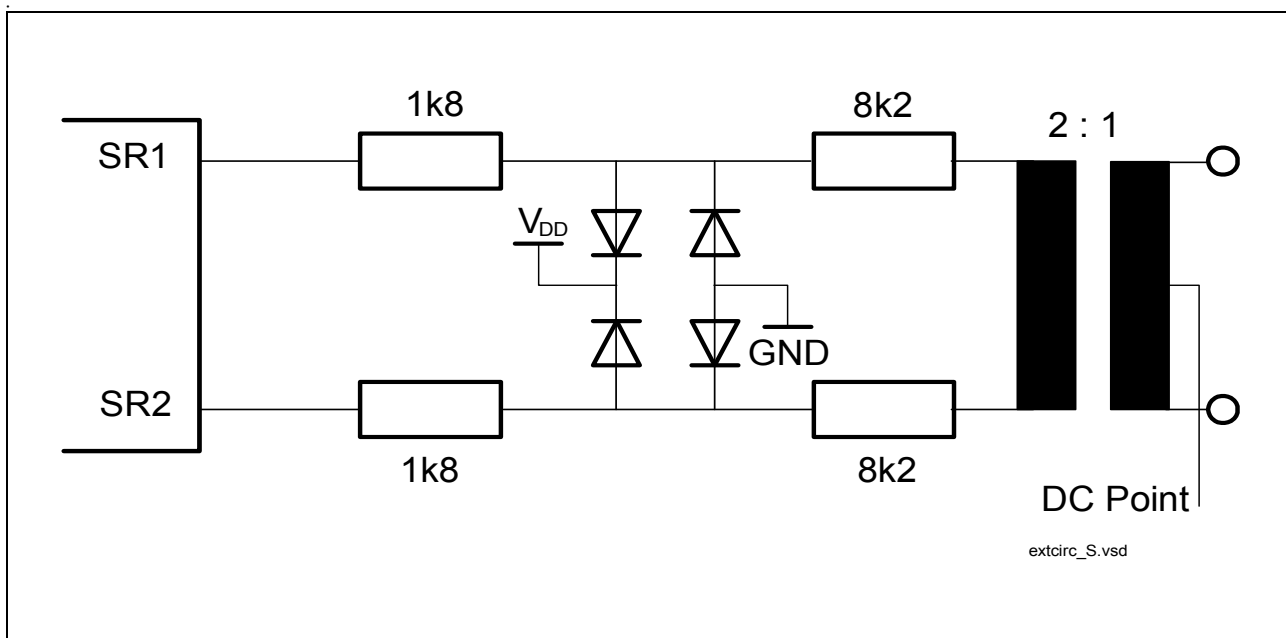

Figure 56 External Circuitry S-Interface Receiver

3.3.4 Oscillator Circuitry

Figure 57 illustrates the recommended oscillator circuit.

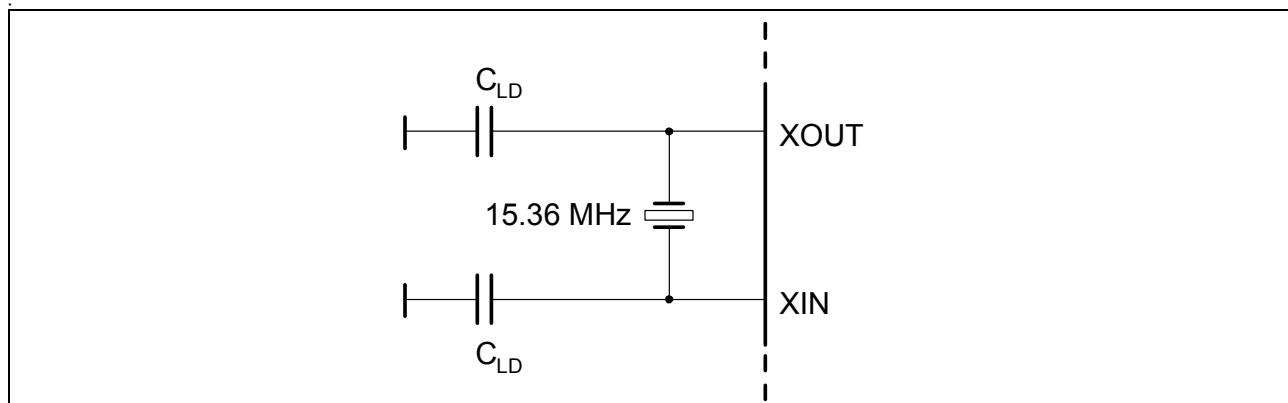

Figure 57 Crystal Oscillator

Table 30 Crystal Parameters

Parameter	Symbol	Limit Values	Unit
Frequency	f	15.36	MHz
Frequency calibration tolerance		+/-60	ppm
Load capacitance	C _L	20	pF
Max. resonance resistance	R1	20	Ω
Max. shunt capacitance	C ₀	7	pF
Oscillator mode		fundamental	

External Components and Parasitics

The load capacitance C_L is computed from the external capacitances C_{LD}, the parasitic capacitances C_{Par} (pin and PCB capacitances to ground and V_{DD}) and the stray capacitance C_{IO} between XIN and XOUT:

$$C_L = \frac{(C_{LD} + C_{Par}) \times (C_{LD} + C_{Par})}{(C_{LD} + C_{Par}) + (C_{LD} + C_{Par})} + C_{IO}$$

For a specific crystal the total load capacitance is predefined, so the equation must be solved for the external capacitances C_{LD}, which is usually the only variable to be determined by the circuit designer. Typical values for the capacitances C_{LD} connected to the crystal are 22 - 33 pF.

3.3.5 General

- low power LEDs

4 Register Description

4.1 Address Space

7D _H	<div style="display: flex; flex-direction: column; align-items: center;"> <div style="border-bottom: 1px solid black; width: 100%; padding: 2px;">U-Transceiver</div> <div style="border-bottom: 1px solid black; width: 100%; padding: 2px;">Monitor Handler</div> <div style="border-bottom: 1px solid black; width: 100%; padding: 2px;">IOM[®]-2 Handler (CDA, TSDP, CR, STI)</div> <div style="border-bottom: 1px solid black; width: 100%; padding: 2px;">Interrupt, Global Registers</div> <div style="border-bottom: 1px solid black; width: 100%; padding: 2px;">S-Transceiver</div> <div style="border-bottom: 1px solid black; width: 100%; padding: 2px;">CI-Register</div> <div style="width: 100%; padding: 2px;">MODEH-Register reserved</div> </div>
60 _H	
5C _H	
40 _H	
3C _H	
30 _H	
2E _H	
22 _H	
00 _H	

Figure 58 Address Space

4.2 Interrupts

Special events in the T-SMINT[®]I are indicated by means of a single interrupt output, which requests the host to read status information from the T-SMINT[®]I or transfer data from/to the T-SMINT[®]I.

Since only one $\overline{\text{INT}}$ request output is provided, the cause of an interrupt must be determined by the host reading the interrupt status registers of the T-SMINT[®]I.

The structure of the interrupt status registers is shown in [Figure 59](#).

Register Description

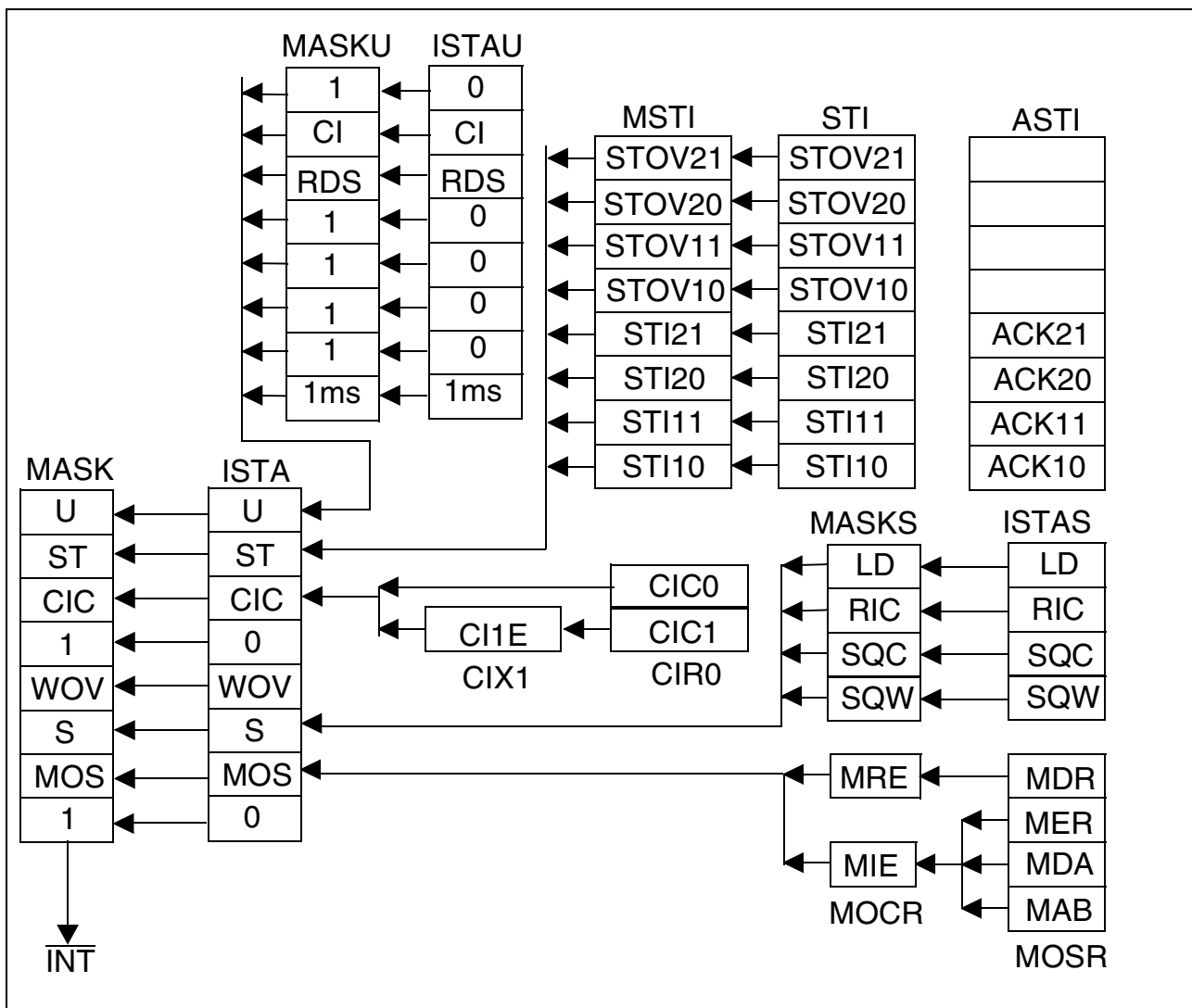

Figure 59 T-SMINT®I Interrupt Status Registers

After the T-SMINT®I has requested an interrupt by setting its \overline{INT} pin to low, the host must read first the T-SMINT®I interrupt status register (ISTA) in the associated interrupt service routine. The \overline{INT} pin of the T-SMINT®I remains active until all interrupt sources are cleared. Therefore, it is possible that the INT pin is still active when the interrupt service routine is finished.

Each interrupt indication of the interrupt status registers can selectively be masked by setting the respective bit in the MASK register.

For some interrupt controllers or hosts it might be necessary to generate a new edge on the interrupt line to recognize pending interrupts. This can be done by masking all interrupts at the end of the interrupt service routine (writing FF_H into the MASK register) and writing back the old mask to the MASK register.

Register Description

4.3 Register Summary

r(0) = reserved, implemented as zero

CI Handler

Name	7	6	5	4	3	2	1	0	ADDR	R/W	RES
MODEH	reserved								00 _H -21 _H		
	1	1	0	r(0)	0	DIM2	DIM1	DIM0	22 _H	R/W	C0 _H
CIR0 CIX0 CIR1 CIX1	reserved								23 _H -2D _H		
	CODR0				CIC0	CIC1	S/G	BAS	2E _H	R	F3 _H
	CODX0				TBA2	TBA1	TBA0	BAC	2E _H	W	FE _H
	CODR1						CICW	CI1E	2F _H	R	FE _H
	CODX1						CICW	CI1E	2F _H	W	FE _H

Register Description

S-Transceiver

Name	7	6	5	4	3	2	1	0	ADDR	R/W	RES
S_CONF0	DIS_TR	BUS	EN_ICV	0	L1SW	0	EXLP	0	30 _H	R/W	40 _H
	reserved								31 _H		
S_CONF2	DIS_TX	0	0	0	0	0	0	0	32 _H	R/W	80 _H
S_STA	RINF		0	ICV	0	FSYN	0	LD	33 _H	R	00 _H
S_CMD	XINF			DPRIO	1	PD	LP_A	0	34 _H	R/W	08 _H
SQRR	MSYN	MFEN	0	0	SQR1	SQR2	SQR3	SQR4	35 _H	R	00 _H
SQXR	0	MFEN	0	0	SQX1	SQX2	SQX3	SQX4	35 _H	W	00 _H
	reserved								36 _H -37 _H		
ISTAS	0	x	x	x	LD	RIC	SQC	SQW	38 _H	R	00 _H
MASKS	1	1	1	1	LD	RIC	SQC	SQW	39 _H	R/W	FF _H
S_MODE	0	0	0	0	DCH_INH	MODE2-0			3A _H	R/W	02 _H
	reserved								3B _H		

Register Description

Interrupt, General Configuration

Name	7	6	5	4	3	2	1	0	ADDR	R/W	RES	
ISTA	U	ST	CIC	0	WOV	S	MOS	0	3C _H	R	00 _H	
MASK	U	ST	CIC	1	WOV	S	MOS	1	3C _H	W	FF _H	
MODE1	MCLK		CDS	WTC1	WTC2	CFS	RSS2	RSS1	3D _H	R/W	04 _H	
MODE2	LED2	LED1	LEDC		0	0	AMOD	PPSDX	3E _H	R/W	00 _H	
ID	0	0	DESIGN							3F _H	R	20 _H
SRES	0	0	RES_ CI/TIC	0	0	0	RES_ S	RES_ U	3F _H	W	00 _H	

Register Description

IOM Handler (Timeslot, Data Port Selection, CDA Data and CDA Control Register)

Name	7	6	5	4	3	2	1	0	ADDR	R/W	RES
CDA10	Controller Data Access Register								40 _H	R/W	FF _H
CDA11	Controller Data Access Register								41 _H	R/W	FF _H
CDA20	Controller Data Access Register								42 _H	R/W	FF _H
CDA21	Controller Data Access Register								43 _H	R/W	FF _H
CDA_ TSDP10	DPS	0	0	0	TSS				44 _H	R/W	00 _H
CDA_ TSDP11	DPS	0	0	0	TSS				45 _H	R/W	01 _H
CDA_ TSDP20	DPS	0	0	0	TSS				46 _H	R/W	80 _H
CDA_ TSDP21	DPS	0	0	0	TSS				47 _H	R/W	81 _H
	reserved								48 _H - 4B _H		
S_ TSDP_ B1	DPS	0	0	0	TSS				4C _H	R/W	84 _H
S_ TSDP_ B2	DPS	0	0	0	TSS				4D _H	R/W	85 _H
CDA1_ CR	0	0	EN_ TBM	EN_I1	EN_I0	EN_O1	EN_O0	SWAP	4E _H	R/W	00 _H
CDA2_ CR	0	0	EN_ TBM	EN_I1	EN_I0	EN_O1	EN_O0	SWAP	4F _H	R/W	00 _H

Register Description

IOM Handler (Control Registers, Synchronous Transfer Interrupt Control)

Name	7	6	5	4	3	2	1	0	ADDR	R/W	RES
	reserved								50 _H		
S_CR	1	CI_CS	EN_D	EN_B2R	EN_B1R	EN_B2X	EN_B1X	D_CS	51 _H	R/W	FF _H
CI_CR	DPS_CI1	EN_CI1	0	0	0	1	0		52 _H	R/W	04 _H
MON_CR	DPS	EN_MON	0	0	0	0	MCS		53 _H	R/W	40 _H
SDS1_CR	ENS_TSS	ENS_TSS+1	ENS_TSS+3	0	TSS				54 _H	R/W	00 _H
SDS2_CR	ENS_TSS	ENS_TSS+1	ENS_TSS+3	0	TSS				55 _H	R/W	00 _H
IOM_CR	SPU	0	0	TIC_DIS	EN_BCL	0	DIS_OD	DIS_IOM	56 _H	R/W	08 _H
MCDA	MCDA21		MCDA20		MCDA11		MCDA10		57 _H	R	FF _H
STI	STOV ₂₁	STOV ₂₀	STOV ₁₁	STOV ₁₀	STI ₂₁	STI ₂₀	STI ₁₁	STI ₁₀	58 _H	R	00 _H
ASTI	0	0	0	0	ACK ₂₁	ACK ₂₀	ACK ₁₁	ACK ₁₀	58 _H	W	00 _H
MSTI	STOV ₂₁	STOV ₂₀	STOV ₁₁	STOV ₁₀	STI ₂₁	STI ₂₀	STI ₁₁	STI ₁₀	59 _H	R/W	FF _H
	reserved								5A _H -5B _H		

Register Description

MONITOR Handler

Name	7	6	5	4	3	2	1	0	ADDR	R/W	RES
MOR	MONITOR Receive Data								5C _H	R	FF _H
MOX	MONITOR Transmit Data								5C _H	W	FF _H
MOSR	MDR	MER	MDA	MAB	0	0	0	0	5D _H	R	00 _H
MOCR	MRE	MRC	MIE	MXC	0	0	0	0	5E _H	R/W	00 _H
MSTA	0	0	0	0	0	MAC	0	TOUT	5F _H	R	00 _H
MCONF	0	0	0	0	0	0	0	TOUT	5F _H	W	00 _H

Register Description

U-Transceiver

Name	7	6	5	4	3	2	1	0	ADDR	R/W	RES
OPMODE	0	UCI	0	0	0	0	0	0	60 _H	R*/W	00 _H
	reserved								61 _H - 6C _H		
UCIR	0	0	0	0	C/I code output				6D _H	R	00 _H
UCIW	0	0	0	0	C/I code input				6E _H	W	01 _H
	reserved								6F _H		
LOOP	0	0	TRANS	U/IOM	1	LBBD	LB2	LB1	70 _H	R*/W	08 _H
	reserved								71 _H		
RDS	Block Error Counter Value								72 _H	R	00 _H
	reserved								73 _H - 79 _H		
ISTAU	0	CI	RDS	0	0	0	0	1 ms	7A _H	R	00 _H
MASKU	1	CI	RDS	1	1	1	1	1 ms	7B _H	R*/W	FF _H
	reserved								7C _H		
FW_VERSION	FW Version Number								7D _H	R	3E _H

Note: Registers, which are denoted as ‘reserved’, may not be accessed by the μ C, neither for read nor for write operations.

4.3.1 Reset of U-Transceiver Functions During Deactivation or with C/I-Code RESET

The following U-transceiver register is reset upon transition to state ‘Deactivating’ or with software reset:

Register Description

Table 31 Reset of U-Transceiver Functions During Deactivation or with C/I-Code RESET

Register	Affected Bits/ Comment
LOOP	only the bits LBBD, LB2 and LB1 are reset

4.3.2 Mode Register Evaluation Timing

Table 32 lists registers, which are evaluated and executed immediately.

Table 32 Mode Register with Immediate Evaluation and Execution

Register	Affected Bits	Comment
OPMODE	UCI	
LOOP	complete register	
MASKU	complete register	

Register Description

4.4 Detailed C/I Registers

4.4.1 MODEH - Mode Register IOM-2

MODEH read/write Address: 22_H
 Value after reset: C0_H

7							0
1	1	0	r(0)	0	DIM2	DIM1	DIM0

DIM2-0 Digital Interface Modes
 These bits define the characteristics of the IOM Data Ports (DU, DD). The DIM0 bit enables/disables the stop/go bit (S/G) evaluation. The DIM1 bit enables/disables the TIC bus access. The effect of the individual DIM bits is as follows:

- 0-0 = Stop/go bit evaluation is disabled
- 0-1 = Stop/go bit evaluation is enabled
- 00- = TIC bus access is enabled
- 01- = TIC bus access is disabled
- 1xx = Reserved

4.4.2 CIR0 - Command/Indication Receive 0

CIR0 read Address: 2E_H
 Value after reset: F3_H

7					0	
CODR0			CIC0	CIC1	S/G	BAS

Register Description**CODR0** C/I0 Code Receive

Value of the received Command/Indication code. A C/I-code is loaded in CODR0 only after being the same in two consecutive IOM-frames and the previous code has been read from CIR0.

CIC0 C/I0 Code Change

0 = No change in the received Command/Indication code has been recognized

1 = A change in the received Command/Indication code has been recognized. This bit is set only when a new code is detected in two consecutive IOM-frames. It is reset by a read of CIR0.

CIC1 C/I1 Code Change

0 = No change in the received Command/Indication code has been recognized

1 = A change in the received Command/Indication code in IOM-channel 1 has been recognized. This bit is set when a new code is detected in one IOM-frame. It is reset by a read of CIR0.

S/G Stop/Go Bit Monitoring

Indicates the availability of the upstream D-channel;

0 = Go

1 = Stop

BAS Bus Access Status

Indicates the state of the TIC-bus:

0 = the T-SMINT[®] I itself occupies the D- and C/I-channel

1 = another device occupies the D- and C/I-channel

Note: The CODR0 bits are updated every time a new C/I-code is detected in two consecutive IOM-frames. If several consecutive valid new codes are detected and CIR0 is not read, only the first and the last C/I code are made available in CIR0 at the first and second read of that register.

Register Description

4.4.3 CIX0 - Command/Indication Transmit 0

CIX0 write Address: 2E_H
 Value after reset: FE_H

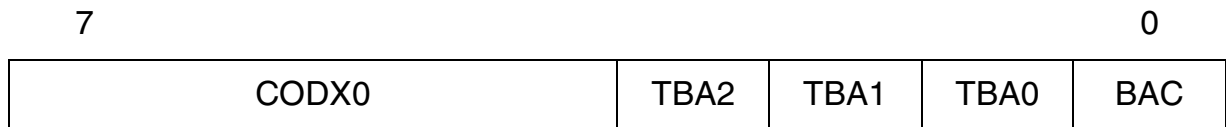

CODX0 C/I0-Code Transmit
 Code to be transmitted in the C/I-channel 0. The code is only transmitted if the TIC bus is occupied, otherwise “1s” are transmitted.

TBA2-0 TIC Bus Address
 Defines the individual address for the T-SMINT[®]I on the IOM bus. This address is used to access the C/I- and D-channel on the IOM interface.
 Note: If only one device is liable to transmit in the C/I- and D-channels of the IOM it should always be given the address value ‘7’.

BAC Bus Access Control
 Only valid if the TIC-bus feature is enabled (MODE:DIM2-0).
 0 = inactive
 1 = The T-SMINT[®]I will try to access the TIC-bus to occupy the C/I-channel even if no D-channel frame has to be transmitted. It should be reset when the access has been completed to grant a similar access to other devices transmitting in that IOM-channel.
 Note: Access is always granted by default to the T-SMINT[®]I with TIC-Bus Address (TBA2-0, CIX0 register) ‘7’, which has the lowest priority in a bus configuration.

4.4.4 CIR1 - Command/Indication Receive 1

CIR1 read Address: 2F_H
 Value after reset: FE_H

Register Description

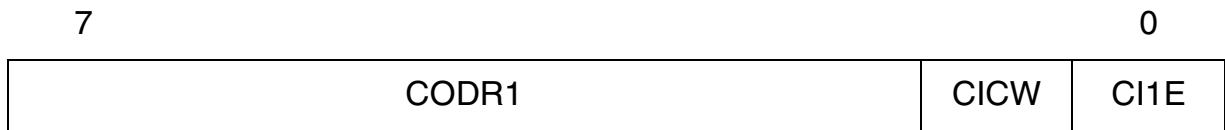

CODR1 C/I1-Code Receive

CICW C/I-Channel Width
 Contains the read back value from CIX1 register (see below)
 0 = 4 bit C/I1 channel width
 1 = 6 bit C/I1 channel width

CI1E C/I1-channel Interrupt Enable
 Contains the read back value from CIX1 register (see below)
 0 = Interrupt generation ISTA.CIC of CIR0.CIC1 is masked
 1 = Interrupt generation ISTA.CIC of CIR0.CIC1 is enabled

4.4.5 CIX1 - Command/Indication Transmit 1

CIX1 write Address: 2F_H
 Value after reset: FE_H

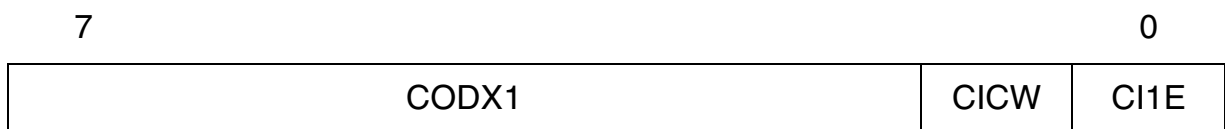

CODX1 C/I1-Code Transmit
 Bits 5-0 of C/I-channel 1

CICW C/I-Channel Width
 0 = 4 bit C/I1 channel width
 1 = 6 bit C/I1 channel width

Register Description

The C/I1 handler always reads and writes 6-bit values but if 4-bit is selected, the higher two bits are ignored for interrupt generation. However, in write direction the full CODX1 code is transmitted, i.e. the host must write the higher two bits to “1”.

- CI1E** C/I1-channel Interrupt Enable
- 0 = Interrupt generation ISTA.CIC of CIR0.CIC1 is masked
 - 1 = Interrupt generation ISTA.CIC of CIR0.CIC1 is enabled

4.5 Detailed S-Transceiver Registers

4.5.1 S_CONF0 - S-Transceiver Configuration Register 0

S_CONF0 read/write Address: 30_H

Value after reset: 40_H

7							0
DIS_TR	BUS	EN_ICV	0	L1SW	0	EXLP	0

- DIS_TR** Disable Transceiver
- 0 = All S-transceiver functions are enabled.
 - 1 = All S-transceiver functions are disabled and powered down (analog and digital parts).

- BUS** Point-to-Point / Bus Selection
- 0 = Adaptive Timing (Point-to-Point, extended passive bus).
 - 1 = Fixed Timing (Short passive bus), directly derived from transmit clock.

- EN_ICV** Enable Far End Code Violation
- 0 = normal operation.
 - 1 = ICV enabled. The receipt of at least one illegal code violation within one multi-frame according to ANSI T1.605 is indicated by the C/I indication ‘1011’ (CVR) in two consecutive IOM frames.

Register Description

L1SW Enable Layer 1 State Machine in Software
 0 = Layer 1 state machine of the T-SMINT®I is used.
 1 = Layer 1 state machine is disabled. The functionality must be realized in software.
 The commands are written to register S_CMD and the status read in the S_STA.

EXLP External Loop
 In case the analog loopback is activated with C/I = ARL or with the LP_A bit in the S_CMD register the loop is a
 0 = internal loop next to the line pins
 1 = external loop which has to be closed between SR1/SR2 and SX1/SX2

Note: For the external loop the transmitter must be enabled (S_CONF2:DIS_TX = 0).

4.5.2 S_CONF2 - S-Transmitter Configuration Register 2

S_CONF2 read/write Address: 32_H
 Value after reset: 80_H

7							0
DIS_TX	0	0	0	0	0	0	0

DIS_TX Disable Line Driver
 0 = Transmitter is enabled
 1 = Transmitter is disabled

4.5.3 S_STA - S-Transceiver Status Register

S_STA read Address: 33_H
 Value after reset: 00_H

Register Description

7						0
RINF	0	ICV	0	FSYN	0	LD

Important: This register is used only if the Layer 1 state machine of the device is disabled (S_CONF0:L1SW = 1) and implemented in software! With the layer 1 state machine enabled, the signals from this register are automatically evaluated.

RINF Receiver INFO
 00 = Received INFO 0 (no signal)
 01 = Received any signal except INFO 0 or INFO 3
 10 = reserved
 11 = Received INFO 3

ICV Illegal Code Violation
 0 = No illegal code violation is detected.
 1 = Illegal code violation (ANSI T1.605) in data stream is detected.

FSYN Frame Synchronization State
 0 = The S/T receiver is not synchronized.
 1 = The S/T receiver has synchronized to the framing bit F.

LD Level Detection
 0 = No receive signal has been detected on the line.
 1 = Any receive signal has been detected on the line.

4.5.4 S_CMD - S-Transceiver Command Register

S_CMD read/write Address: 34_H
 Value after reset: 08_H

7					0
XINF	DPRIO	1	PD	LP_A	0

Register Description

Important: This register - except bit DPRIO - is writable only if the Layer 1 state machine of the device is disabled (S_CONF0.L1SW = 1) and implemented in software! With the device layer 1 state machine enabled, the signals from this register are automatically generated. DPRIO can also be written in intelligent NT mode.

XINF Transmit INFO

- 000 = Transmit INFO 0
- 001 = reserved
- 010 = Transmit INFO 2
- 011 = Transmit INFO 4
- 100 = Send continuous pulses at 192 kbit/s alternating or 96 kHz rectangular, respectively (TM2)
- 101 = Send single pulses at 4 kbit/s with alternating polarity corresponding to 2 kHz fundamental mode (TM1)
- 11x = reserved

DPRIO D-Channel Priority

- 0 = Priority class 1 for D channel access on IOM
- 1 = Priority class 2 for D channel access on IOM

PD Power Down

- 0 = The transceiver is set to operational mode
- 1 = The transceiver is set to power down mode

LP_A Loop Analog

The setting of this bit corresponds to the C/I command ARL.

- 0 = Analog loop is open
- 1 = Analog loop is closed internally or externally according to the EXLP bit in the S_CONF0 register

4.5.5 SQRR - S/Q-Channel Receive Register

SQRR read Address: 35_H

Value after reset: 00_H

Register Description

7							0
MSYN	MFEN	0	0	SQR1	SQR2	SQR3	SQR4

MSYN Multi-frame Synchronization State

0 = The S/T receiver has not synchronized to the received F_A and M bits

1 = The S/T receiver has synchronized to the received F_A and M bits

MFEN Multiframe Enable

Read-back of the MFEN bit of the SQXR register

0 = S/T multiframe is disabled

1 = S/T multiframe is enabled

SQR1-4 Received S/Q Bits

Received Q bits in frames 1, 6, 11 and 16

4.5.6 SQXR- S/Q-Channel Transmit Register

SQXR write Address: 35_H

Value after reset: 00_H

7							0
0	MFEN	0	0	SQX1	SQX2	SQX3	SQX4

MFEN Multiframe Enable

Used to enable or disable the multiframe structure.

0 = S/T multiframe is disabled

1 = S/T multiframe is enabled

SQX1-4 Transmitted S/Q Bits

Transmitted S bits in frames 1, 6, 11 and 16

4.5.7 ISTAS - Interrupt Status Register S-Transceiver

ISTAS read Address: 38_H

Value after reset: 00_H

7							0
x	x	x	x	LD	RIC	SQC	SQW

These bits are set if an interrupt status occurs and an interrupt signal is activated if the corresponding mask bit is set to “0”. If the mask bit is set to “1” no interrupt is generated, however the interrupt status bit is set in ISTAS. RIC, SQC and SQW are cleared by reading the corresponding source register S_STA, SQRR or writing SQXR, respectively.

x Reserved

LD Level Detection

0 = inactive

1 = Any receive signal has been detected on the line. This bit is set to “1” (i.e. an interrupt is generated if not masked) as long as any receive signal is detected on the line.

RIC Receiver INFO Change

0 = inactive

1 = RIC is activated if one of the S_STA bits RINF or ICV has changed.

SQC S/Q-Channel Change

0 = inactive

1 = A change in the received 4-bit Q-channel has been detected. The new code can be read from the SQRx bits of registers SQRR within the next multiframe¹⁾. This bit is reset by a read access to the SQRR register.

SQW S/Q-Channel Writable

Register Description

- 0 = inactive
- 1 = The S channel data for the next multiframe is writable.
 The register for the S bits to be transmitted has to be written within the next multiframe. This bit is reset by writing register SQXR. This timing signal is indicated with the start of every multiframe. Data which is written right after SQW-indication will be transmitted with the start of the following multiframe. Data which is written before SQW-indication is transmitted in the multiframe which is indicated by SQW.
 SQW and SQC could be generated at the same time.

1) Register SQRR stays valid as long as no code change has been received.

4.5.8 MASKS - Mask S-Transceiver Interrupt

MASKS read/write Address: 39_H
 Value after reset: FF_H

7							0
1	1	1	1	LD	RIC	SQC	SQW

Bit 3..0 Mask bits
 0 = The transceiver interrupts LD, RIC, SQC and SQW are enabled
 1 = The transceiver interrupts LD, RIC, SQC and SQW are masked

4.5.9 S_MODE - S-Transceiver Mode

S_MODE read/write Address: 3A_H
 Value after reset: 02_H

7							0
0	0	0	0	DCH_INH	MODE		

DCH_ D-Channel Inhibit
INH

- 0 = inactive
- 1 = The S-transceiver blocks the access to the D-channel on S by inverting the E-bits.

MODE Mode Selection

- 000 = reserved
- 001 = reserved
- 010 = NT (without D-channel handler)
- 011 = LT-S (without D-channel handler)
- 110 Intelligent NT mode (with NT state machine and with D-channel handler)
- 111 Intelligent NT mode (with LT-S state machine and with D-channel handler)
- 100 reserved
- 101 reserved

4.6 Interrupt and General Configuration Registers

4.6.1 ISTA - Interrupt Status Register

ISTA read Address: 3C_H

Value after reset: 00_H

	7						0	
	U	ST	CIC	0	WOV	S	MOS	0

U U-Transceiver Interrupt

- 0 = inactive
- 1 = An interrupt was generated by the U-transceiver. Read the ISTAU register.

Register Description

- ST** Synchronous Transfer
 0 = inactive
 1 = This interrupt enables the microcontroller to lock on to the IOM[®]-2 timing, for synchronous transfers.
- CIC** C/I Channel Change
 0 = inactive
 1 = A change in C/I0 channel or C/I1 channel has been recognized. The actual value can be read from CIR0 or CIR1.
 0 = inactive
- WOV** Watchdog Timer Overflow
 0 = inactive
 1 = Signals the expiration of the watchdog timer, which means that the microcontroller has failed to set the watchdog timer control bits WTC1 and WTC2 (MODE1 register) in the correct manner. A reset out pulse on pin $\overline{\text{RSTO}}$ has been generated by the T-SMINT[®]I.
- S** S-Transceiver Interrupt
 0 = inactive
 1 = An interrupt was generated by the S-transceiver. Read the ISTAS register.
- MOS** MONITOR Status
 0 = inactive
 1 = A change in the MONITOR Status Register (MOSR) has occurred.
 0 = inactive

Note: A read of the ISTA register clears only the WOVS interrupt. The other interrupts are cleared by reading the corresponding status register.

4.6.2 MASK - Mask Register

MASK write Address: 3C_H
 Value after reset: FF_H

Register Description

7							0
U	ST	CIC	1	WOV	S	MOS	1

Bit 7..0 Mask bits

- 0 = Interrupt is not masked
- 1 = Interrupt is masked

Each interrupt source in the ISTA register can be selectively masked by setting the corresponding bit in MASK to '1'. Masked interrupt status bits are not indicated when ISTA is read. Instead, they remain internally stored and pending, until the mask bit is reset to '0'.

Note: In the event of a C/I channel change, CIC is set in ISTA even if the corresponding mask bit in MASK is active, but no interrupt is generated.

4.6.3 MODE1 - Mode1 Register

MODE1 read/write Address: 3D_H
 Value after reset: 04_H

7							0
MCLK	CDS	WTC1	WTC2	CFS	RSS2	RSS1	

MCLK Master Clock Frequency

The Master Clock Frequency bits control the microcontroller clock output depending on MODE1.CDS = '0' or '1' (Table [Table 2.1.3](#)).

	MODE1.CDS = '0'	MODE1.CDS = '1'
00 =	3.84 MHz	7.68 MHz
01 =	0.96 MHz	1.92 MHz
10 =	7.68 MHz	15.36 MHz
11 =	disabled	disabled

Register Description

CDS Clock Divider Selection

- 0 = The 15.36 MHz oscillator clock divided by two is input to the MCLK prescaler
- 1 = The 15.36 MHz oscillator clock is input to the MCLK prescaler.

WTC1, 2 Watchdog Timer Control 1, 2

After the watchdog timer mode has been selected (RSS = '11') the watchdog timer is started. During every time period of 128 ms the microcontroller has to program the WTC1 and WTC2 bit in the following sequence ([Chapter 2.2](#)):

- 10 first step
- 01 second step

to reset and restart the watchdog timer.

If not, the timer expires and a WOV-interrupt (ISTA Register) together with a reset out pulse on pin $\overline{\text{RSTO}}$ is generated.

The watchdog timer runs only when the internal IOM[®]-2 clocks are active, i.e. the watchdog timer is dead when bit CFS = 1 and the U and S-transceivers are in state power down.

CFS Configuration Select

- 0 = The IOM[®]-2 interface clock and frame signals are always active, "Deactivated State" of the U-transceiver and the S-transceiver included.
- 1 = The IOM[®]-2 interface clocks and frame signals are inactive in the "Deactivated State" of the U-transceiver and the S-transceiver.

RSS2, RSS1 Reset Source Selection 2,1

The T-SMINT[®]I reset sources can be selected according to the table below.

	C/I Code Change	Watchdog Timer	POR/UVD and $\overline{\text{RST}}$
00 =	--	--	x
01 =		$\overline{\text{RSTO}}$ disabled (high impedance)	
10 =	x	--	x
11 =	--	x	x

4.6.4 MODE2 - Mode2 Register

MODE2 read/write Address: 3E_H

Value after reset: 00_H

	7						0

Register Description

	7								0
	0	0	DESIGN						

DESIGN Design Number

The design number (DESIGN) allows to identify different hardware designs¹⁾ of the T-SMINT[®]I by software.

100000: Version 1.1

¹⁾ Distinction of different firmware versions is also possible by reading register (7D)_H in the address space of the U-transceiver (see [Chapter 4.9.8](#)).

4.6.6 SRES - Software Reset Register

SRES write Address: 3F_H

Value after reset: 00_H

	7								0
	0	0	RES_ CI/TIC	0	0	0	RES_S	RES_U	

RES_xx Reset_xx

0 = Deactivates the reset of the functional block xx

1 = Activates the reset of the functional block xx.

The reset state is activated as long as the bit is set to '1'

4.7 Detailed IOM[®]-2 Handler Registers

4.7.1 CDAXy - Controller Data Access Register xy

These registers are used for microcontroller access to the IOM[®]-2 timeslots as well as for timeslot manipulations. (e.g. loops, shifts, ... see also [“Controller Data Access \(CDA\)” on Page 30](#)).

Register Description

CDAxy read/write Address: 40-43_H



Data register CDAxy which can be accessed by the controller.

Register	Value after Reset	Register Address
CDA10	FF _H	40 _H
CDA11	FF _H	41 _H
CDA20	FF _H	42 _H
CDA21	FF _H	43 _H

4.7.2 XXX_TSDPxy - Time Slot and Data Port Selection for CHxy

XXX_TSDPxy read/write Address: 44-4D_H

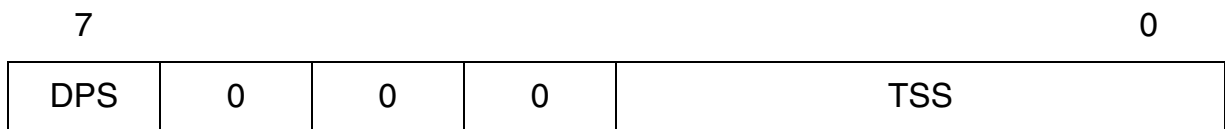

Register	Value after Reset	Register Address
CDA_TSDP10	00 _H (= output on B1-DD)	44 _H
CDA_TSDP11	01 _H (= output on B2-DD)	45 _H
CDA_TSDP20	80 _H (= output on B1-DU)	46 _H
CDA_TSDP21	81 _H (= output on B2-DU)	47 _H
	reserved	48-4B _H
S_TSDP_B1	84 _H (= output on TS4-DU)	4C _H
S_TSDP_B2	85 _H (= output on TS5-DU)	4D _H

This register determines the time slots and the data ports on the IOM[®]-2 Interface for the data channels xy of the functional units XXX (Controller Data Access (CDA) and S-transceiver (S)).

Note: The U-transceiver is always in IOM-2 channel 0.

Register Description

DPS Data Port Selection

- 0 = The data channel xy of the functional unit XXX is output on DD.
The data channel xy of the functional unit XXX is input from DU.
- 1 = The data channel xy of the functional unit XXX is output on DU.
The data channel xy of the functional unit XXX is input from DD.

Note: For the CDA (controller data access) data the input is determined by the CDAX_CR.SWAP bit. If SWAP = '0' the input for the CDAXy data is vice versa to the output setting for CDAXy. If the SWAP = '1' the input from CDAX0 is vice versa to the output setting of CDAX1 and the input from CDAX1 is vice versa to the output setting of CDAX0.

TSS Timeslot Selection

Selects one of the 12 timeslots from 0...11 on the IOM[®]-2 interface for the data channels.

4.7.3 CDAX_CR - Control Register Controller Data Access CH1x

CDAX_CR read/write Address: 4E-4F_H

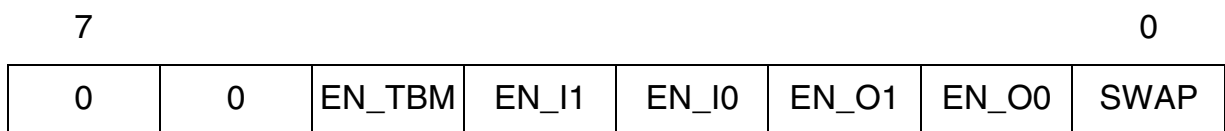

Register	Value after Reset	Register Address
CDA1_CR	00 _H	4E _H
CDA2_CR	00 _H	4F _H

EN_TBM Enable TIC Bus Monitoring

- 0 = The TIC bus monitoring is disabled
- 1 = The TIC bus monitoring with the CDAX0 register is enabled. The TSDPx0 register must be set to 08_H for monitoring from DU, or 88_H for monitoring from DD.

EN_I1, EN_I0 Enable Input CDAX1, CDAX0

Register Description

- 0 = The input of the CDAX1, CDAX0 register is disabled
- 1 = The input of the CDAX1, CDAX0 register is enabled

EN_O1, EN_O0 Enable Output CDAX1, CDAX0

- 0 = The output of the CDAX1, CDAX0 register is disabled
- 1 = The output of the CDAX1, CDAX0 register is enabled

SWAP Swap Inputs

- 0 = The time slot and data port for the input of the CDAXy register is defined by its own TSDPxy register. The data port for the CDAXy input is vice versa to the output setting for CDAXy.
- 1 = The input (time slot and data port) of the CDAX0 is defined by the TSDP register of CDAX1 and the input of CDAX1 is defined by the TSDP register of CDAX0. The data port for the CDAX0 input is vice versa to the output setting for CDAX1. The data port for the CDAX1 input is vice versa to the output setting for CDAX0. The input definition for time slot and data port CDAX0 are thus swapped to CDAX1 and for CDAX1 to CDAX0. The outputs are not affected by the SWAP bit.

4.7.4 S_CR - Control Register S-Transceiver Data

S_CR read/write Address: 51_H

Value after reset: FF_H

7								0
1	CI_CS	EN_D	EN_B2R	EN_B1R	EN_B2X	EN_B1X	D_CS	

CI_CS C/I Channel Selection

This bit is used to select the IOM channel to which the S-transceiver C/I-channel is related to.

- 0 = C/I-channel in IOM-channel 0
- 1 = C/I-channel in IOM-channel 1

Register Description

EN_D Enable Transceiver D-Channel Data

0 = The corresponding data path to the transceiver is disabled

1 = The corresponding data path to the transceiver is enabled.

EN_B2R Enable Transceiver B2 Receive Data (transmitter receives from IOM)

0 = The corresponding data path to the transceiver is disabled

1 = The corresponding data path to the transceiver is enabled.

EN_B1R Enable Transceiver B1 Receive Data (transmitter receives from IOM)

0 = The corresponding data path to the transceiver is disabled

1 = The corresponding data path to the transceiver is enabled.

EN_B2X Enable Transceiver B2 Transmit Data (transmitter transmits to IOM)

0 = The corresponding data path to the transceiver is disabled

1 = The corresponding data path to the transceiver is enabled.

EN_B1X Enable Transceiver B1 Transmit Data (transmitter transmits to IOM)

0 = The corresponding data path to the transceiver is disabled

1 = The corresponding data path to the transceiver is enabled.

These bits are used to individually enable/disable the D-channel and the receive/transmit paths for the B-channels for the S-transceiver.

D_CS D Channel Selection

This bit is used to select the IOM channel to which the S-transceiver D-channel is related to.

0 = D-channel in IOM-channel 0

1 = D-channel in IOM-channel 1

4.7.5 CI_CR - Control Register for CI1 Data

CI_CR read/write Address: 52_H

Value after reset: 04_H

Register Description

7						0
DPS_CI1	EN_CI1	0	0	0	1	0

DPS_CI1 Data Port Selection CI1 Handler

- 0 = The CI1 data is output on DD and input from DU
- 1 = The CI1 data is output on DU and input from DD

EN_CI1 Enable CI1 Handler

- 0 = CI1 data access is disabled
- 1 = CI1 data access is enabled

Note: The timeslot for the C/I1 handler cannot be programmed but is fixed to IOM channel 1.

4.7.6 MON_CR - Control Register Monitor Data

MON_CR read/write Address: 53_H
 Value after reset: 40_H

7						0
DPS	EN_MON	0	0	0	0	MCS

DPS Data Port Selection

- 0 = The Monitor data is output on DD and input from DU
- 1 = The Monitor data is output on DU and input from DD

EN_MON Enable Output

- 0 = The Monitor data input and output is disabled
- 1 = The Monitor data input and output is enabled

MCS MONITOR Channel Selection

- 00 = The MONITOR data is output on MON0

Register Description

TSS Timeslot Selection

Selects one of 12 timeslots on the IOM[®]-2 interface (with respect to FSC) during which SDS2 is active high. The data strobe signal allows standard data devices to access a programmable channel.

4.7.9 IOM_CR - Control Register IOM Data

IOM_CR read/write Address: 56_H

Value after reset: 08_H

7							0
SPU	0	0	TIC_DIS	EN_BCL	0	DIS_OD	DIS_IOM

SPU Software Power UP

0 = The DU line is normally used for transmitting data.

1 = Setting this bit to '1' will pull the DU line to low. This will enforce the T-SMINT[®]I and other connected layer 1 devices to deliver IOM-clocking.

TIC_DIS TIC Bus Disable

0 = The last octet of the last IOM time slot (TS 11) is used as TIC bus.

1 = The TIC bus is disabled. The last octet of the last IOM time slot (TS 11) can be used like any other time slot. This means that the timeslots TIC, A/B, S/G and BAC are not available any more.

EN_BCL Enable Bit Clock BCL

0 = The BCL clock is disabled (output is high impedant)

1 = The BCL clock is enabled

DIS_OD Disable Open Drain

0 = IOM outputs are open drain driver

1 = IOM outputs are push pull driver

Register Description

DIS_IOM Disable IOM

DIS_IOM should be set to '1' if external devices connected to the IOM interface should be "disconnected" e.g. for power saving purposes. However, the T-SMINT[®]I internal operation is independent of the DIS_IOM bit.

0 = The IOM interface is enabled

1 = The IOM interface is disabled (FSC, DCL, clock outputs have high impedance; DU, DD data line inputs are switched off and outputs are high impedant)

4.7.10 MCDA - Monitoring CDA Bits

MCDA read Address: 57_H

Value after reset: FF_H

7							0
MCDA21	MCDA20		MCDA11		MCDA10		
Bit7 Bit6	Bit7 Bit6	Bit7 Bit6	Bit7 Bit6	Bit7 Bit6	Bit7 Bit6	Bit7 Bit6	

MCD_{Axy} Monitoring CDA_{xy} Bits

Bit 7 and Bit 6 of the CDA_{xy} registers are mapped into the MCDA register. This can be used for monitoring the D-channel bits on DU and DD and the "Echo bits" on the TIC bus with the same register.

4.7.11 STI - Synchronous Transfer Interrupt

STI read Address: 58_H

Value after reset: 00_H

7							0
STOV21	STOV20	STOV11	STOV10	STI21	STI20	STI11	STI10

Register Description

For all interrupts in the STI register the following logical states are applied

- 0 = Interrupt has not occurred
- 1 = Interrupt has occurred

STOVxy Synchronous Transfer Overflow Interrupt

Enabled STOV interrupts for a certain STIxy interrupt are generated when the STIxy has not been acknowledged in time via the ACKxy bit in the ASTI register. This must be one (for DPS = '0') or zero (for DPS = '1') BCL clock cycles before the time slot which is selected for the STOV.

STIxy Synchronous Transfer Interrupt

Depending on the DPS bit in the corresponding TSDPxy register the Synchronous Transfer Interrupt STIxy is generated two (for DPS = '0') or one (for DPS = '1') BCL clock cycles after the selected time slot (TSDPxy.TSS).

Note: STOVxy and ACKxy are useful for synchronizing microcontroller accesses and receive/transmit operations. One BCL clock is equivalent to two DCL clocks.

4.7.12 ASTI - Acknowledge Synchronous Transfer Interrupt

ASTI write Address: 58_H
Value after reset: 00_H

	7						0	
	0	0	0	0	ACK21	ACK20	ACK11	ACK10

ACKxy Acknowledge Synchronous Transfer Interrupt

After a STIxy interrupt the microcontroller has to acknowledge the interrupt by setting the corresponding ACKxy bit.

- 0 = No activity is initiated
- 1 = Sets the acknowledge bit ACKxy for a STIxy interrupt

4.7.13 MSTI - Mask Synchronous Transfer Interrupt

MSTI read/write Address: 59_H

Value after reset: FF_H

7							0
STOV21	STOV20	STOV11	STOV10	STI21	STI20	STI11	STI10

For the MSTI register the following logical states are applied:

- 0 = Interrupt is not masked
- 1 = Interrupt is masked

STOVxy Mask Synchronous Transfer Overflow xy
Mask bits for the corresponding STOVxy interrupt bits.

STIxy Synchronous Transfer Interrupt xy
Mask bits for the corresponding STIxy interrupt bits.

4.8 Detailed MONITOR Handler Registers

4.8.1 MOR - MONITOR Receive Channel

MOR read Address: 5C_H

Value after reset: FF_H

7	0

Contains the MONITOR data received in the IOM[®]-2 MONITOR channel according to the MONITOR channel protocol. The MONITOR channel (0,1,2) can be selected by setting the monitor channel select bit MON_CR.MCS.

Register Description

4.8.2 MOX - MONITOR Transmit Channel

MOX write Address: 5C_H

Value after reset: FF_H

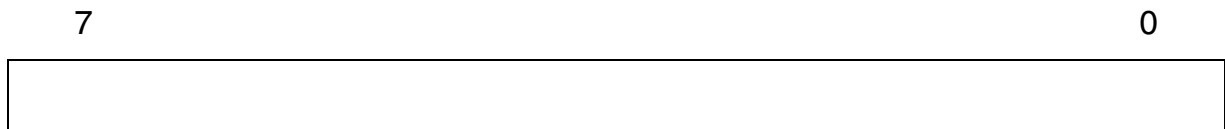

Contains the MONITOR data to be transmitted in IOM[®]-2 MONITOR channel according to the MONITOR channel protocol. The MONITOR channel (0,1,2) can be selected by setting the monitor channel select bit MON_CR.MCS

4.8.3 MOSR - MONITOR Interrupt Status Register

MOSR read Address: 5D_H

Value after reset: 00_H

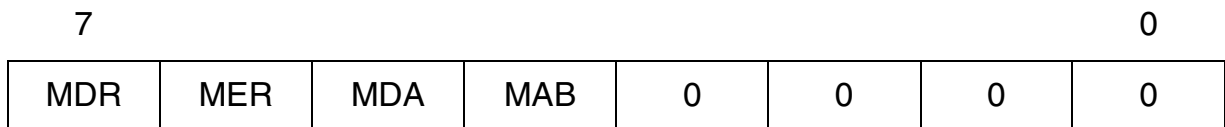

MDR MONITOR channel Data Received
 0 = inactive
 1 = MONITOR channel Data Received

MER MONITOR channel End of Reception
 0 = inactive
 1 = MONITOR channel End of Reception

MDA MONITOR channel Data Acknowledged
 The remote end has acknowledged the MONITOR byte being transmitted.
 0 = inactive
 1 = MONITOR channel Data Acknowledged

MAB MONITOR channel Data Abort

Register Description

- 0 = inactive
- 1 = MONITOR channel Data Abort

4.8.4 MOCR - MONITOR Control Register

MOCR read/write Address: 5E_H
 Value after reset: 00_H

7							0
MRE	MRC	MIE	MXC	0	0	0	0

MRE MONITOR Receive Interrupt Enable

- 0 = MONITOR interrupt status MDR generation is masked.
- 1 = MONITOR interrupt status MDR generation is enabled.

MRC MR Bit Control

Determines the value of the MR bit:

- 0 = MR is always '1'. In addition, the MDR interrupt is blocked, except for the first byte of a packet (if MRE = 1).
- 1 = MR is internally controlled by the T-SMINT[®]I according to MONITOR channel protocol. In addition, the MDR interrupt is enabled for all received bytes according to the MONITOR channel protocol (if MRE = 1).

MIE MONITOR Interrupt Enable

- 0 = MONITOR interrupt status MER, MDA, MAB generation is masked
- 1 = MONITOR interrupt status MER, MDA, MAB generation is enabled

MXC MX Bit Control

Determines the value of the MX bit:

- 0 = The MX bit is always '1'.
- 1 = The MX bit is internally controlled by the T-SMINT[®]I according to MONITOR channel protocol.

Register Description

4.8.5 MSTA - MONITOR Status Register

MSTA read Address: 5F_H
 Value after reset: 00_H

7							0
0	0	0	0	0	MAC	0	TOUT

MAC MONITOR Transmit Channel Active
 0 = No data transmission in the MONITOR channel
 1 = The data transmission in the MONITOR channel is in progress.

TOUT Time-Out
 Read-back value of the TOUT bit
 0 = The monitor time-out function is disabled
 1 = The monitor time-out function is enabled

4.8.6 MCONF - MONITOR Configuration Register

MCONF write Address: 5F_H
 Value after reset: 00_H

7							0
0	0	0	0	0	0	0	TOUT

TOUT Time-Out
 0 = The monitor time-out function is disabled
 1 = The monitor time-out function is enabled

4.9 Detailed U-Transceiver Registers

4.9.1 OPMODE - Operation Mode Register

The **Operation Mode** register determines the operating mode of the U-transceiver.

OPMODE read^{*)}/write Address: 60_H

Reset value: 00_H

7	6	5	4	3	2	1	0
0	UCI	0	0	0	0	0	0

UCI Enable/Disable μ P-control of C/I codes

0 = μ P control disabled - C/I codes are exchanged via IOM[®]-2
Read access to register UCIR by the μ P is still possible

1 = μ P control enabled - C/I codes are exchanged via UCIR and UCIW registers
In this case, the according C/I-channel on IOM[®]-2 is idle '1111'

4.9.2 UCIR - C/I Code Read Register

Via the **U-transceiver C/I code Read** register a microcontroller can access the C/I code that is output from the state machine.

UCIR read Address: 6D_H

Reset value: 00_H

7	6	5	4	3	2	1	0
0	0	0	0	C/I code output			

4.9.3 UCIW - C/I Code Write Register

The **U-transceiver C/I code Write** register allows a microcontroller to control the state of the U-transceiver. To enable this function bit UCI in register OPMODE must be set to '1' before.

Register Description

UCIW **write** Address: 6E_H

Reset value: 01_H

7	6	5	4	3	2	1	0
0	0	0	0	C/I code input			

4.9.4 LOOP - Loopback Register

The **Loop** register controls local digital loopbacks of the U-transceiver.

LOOP read^{*)}/write Address: 70_H

Reset value: 08_H

7	6	5	4	3	2	1	0
0	0	TRANS	U/IOM	1	LBBD	LB2	LB1

TRANS Transparent/ Non-Transparent Loopback
 In transparent mode data is both passed on and looped back, whereas in non-transparent mode data is not forwarded but substituted by 1s (idle code) and just looped back
 0 = transparent mode
 1 = non-transparent mode
 '1's are sent on the IOM[®]-2 interface in the corresponding time-slot

U/IOM[®] Close LBBD, LB2, LB1 towards U or towards IOM[®]
 Switch that selects whether loopback LB1, LB2 or LBBD is closed towards U or towards IOM[®]-2
 the setting affects all test loops, LBBD, LB2 and LB1
 an individual selection for LBBD, LB2, LB1 is not possible
 0 = LB1, LB2, LBBD loops are closed towards IOM[®]
 1 = LB1, LB2, LBBD loops are closed towards U

Register Description

LBBD Close complete loop (B1, B2, D) near the system interface

- the direction towards which the loop is closed is determined by bit U/IOM[®]
- the state machine has to be in state 'Transparent' first (e.g. by C/I = DT) before data is output on the U-interface

0 = complete loopback open
 1 = complete loopback closed

LB2 Close loop B2 near the system interface

- the direction towards which the loop is closed is determined by bit U/IOM[®]
- the state machine has to be in state 'Transparent' first (e.g. by C/I = DT) before data is output on the U-interface

0 = loopback B2 open
 1 = loopback B2 closed

LB1 Close loop B1 near the system interface

- the direction towards which the loop is closed is determined by bit U/IOM[®]
- the state machine has to be in state 'Transparent' first (e.g. by C/I = DT) before data is output on the U-interface

0 = loopback B1 open
 1 = loopback B1 closed

4.9.5 RDS - Block Error Counter Register

see [Chapter 2.4.4.2](#).

RDS read Address: 72_H

Reset value: 00_H

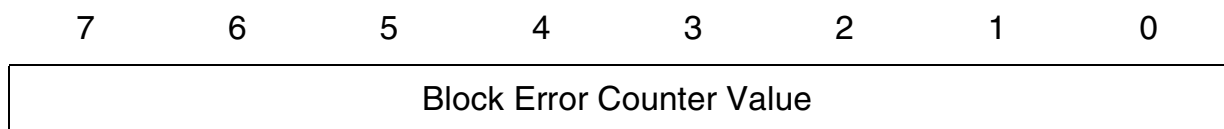

4.9.6 ISTAU - Interrupt Status Register U-Interface

The Interrupt **Status** register **U**-interface generates an interrupt for the unmasked interrupt flags. Refer to [Chapter 2.4.8](#) for details on masking and clearing of interrupt flags.

Register Description

ISTAU read Address: 7A_H

Reset value: 00_H

	7	6	5	4	3	2	1	0
	0	CI	RDS	0	0	0	0	1 ms

CI C/I code indication
the CI interrupt is generated independently on OPMODE.UCI
0 = inactive
1 = CI code change has occurred

RDS Code violation occurred
0 = inactive
1 = code violation has occurred

1 ms Start of a new frame on the U-interface
useful for synchronization of register accesses by an external μ C
0 = inactive
1 = signals the start of a new frame on the U-interface

4.9.7 MASKU - Mask Register U-Interface

The Interrupt **Mask** register **U-Interface** selectively masks each interrupt source in the ISTAU register by setting the corresponding bit to '1'.

MASKU read^{*)}/write Address: 7B_H

Reset Value: FF_H

	7	6	5	4	3	2	1	0
	1	CI	RDS	1	1	1	1	1 ms

Register Description

Bit 0..7 Mask bits
 0 = interrupt active
 1 = interrupt masked

4.9.8 FW_VERSION

FW_VERSION Register contains the Firmware Version number

FW_VERSION **read** Address: 7D_H
 Reset value: 3E_H

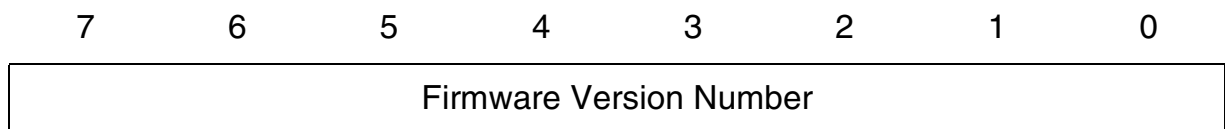

5 Electrical Characteristics

5.1 Absolute Maximum Ratings

Parameter	Symbol	Limit Values	Unit
Ambient temperature under bias	T_A	-40 to 85	°C
Storage temperature	T_{STG}	- 65 to 150	°C
Maximum Voltage on V_{DD}	V_{DD}	4.2	V
Maximum Voltage on any pin with respect to ground	V_S	-0.3 to $V_{DD} + 3.3$ (max. < 5.5)	V

ESD integrity (according EIA/JESD22-A114B (HBM)): 2 kV

Note: Stress above those listed here may cause permanent damage to the device. Exposure to absolute maximum ratings conditions for extended periods may affect device reliability.

Line Overload Protection

The T-SMINT[®]I is compliant to ESD tests according to ANSI / EOS / ESD-S 5.1-1993 (CDM), EIA/JESD22-A114B (HBM) and to Latch-up tests according to JEDEC EIA / JESD78. From these tests the following max. input currents are derived (**Table 33**):

Table 33 Maximum Input Currents

Test	Pulse Width	Current	Remarks
ESD	100 ns	1.3 A	3 repetitions
Latch-up	5 ms	+/-200 mA	2 repetitions, respectively
DC	--	10 mA	

Electrical Characteristics

5.2 DC Characteristics

$V_{DD}/V_{DDA} = 3.3\text{ V} \pm 5\%$; $V_{SS}/V_{SSA} = 0\text{ V}$; $T_A = -40\text{ to }85\text{ }^\circ\text{C}$

Digital Pins	Parameter	Symbol	Limit Values		Unit	Test Condition
			min.	max.		
All	Input low voltage	V_{IL}	-0.3	0.8	V	
	Input high voltage	V_{IH}	2.0	5.25	V	
All except DD/DU ACT, LP2I MCLK	Output low voltage	V_{OL1}		0.45	V	$I_{OL1} = 3.0\text{ mA}$
	Output high voltage	V_{OH1}	2.4		V	$I_{OH1} = 3.0\text{ mA}$
DD/DU ACT, LP2I MCLK	Output low voltage	V_{OL2}		0.45	V	$I_{OL2} = 4.0\text{ mA}$
	Output high voltage (DD/DU push-pull)	V_{OH2}	2.4		V	$I_{OH2} = 4.0\text{ mA}$
All	Input leakage current	I_{LI}		10	μA	$0\text{ V} \leq V_{IN} \leq V_{DD}$
	Output leakage current	I_{LO}		10	μA	$0\text{ V} \leq V_{IN} \leq V_{DD}$
Analog Pins						
AIN, BIN	Input leakage current	I_{LI}		30	μA	$0\text{ V} \leq V_{IN} \leq V_D$ D

Table 34 S-Transceiver Characteristics

Pin	Parameter	Symbol	Limit Values			Unit	Test Condition
			min.	typ.	max.		
SX1,2	Absolute value of output pulse amplitude ($V_{SX2} - V_{SX1}$)	V_X	2.03	2.2	2.31	V	$R_L = 50\ \Omega$
SX1,2	S-Transmitter output impedance	Z_X	10	34		$k\Omega$	see ¹⁾
			0				see ²⁾³⁾
SR1,2	S-Receiver input impedance	Z_R	10 100			$k\Omega$ Ω	$V_{DD} = 3.3\text{ V}$ $V_{DD} = 0\text{ V}$

¹⁾ Requirement ITU-T I.430, chapter 8.5.1.1a): 'At all times except when transmitting a binary zero, the output impedance, in the frequency range of 2kHz to 1 MHz, shall exceed the impedance indicated by the template in Figure 11. The requirement is applicable with an applied sinusoidal voltage of 100 mV (r.m.s value)'

Electrical Characteristics

- 2) Requirement ITU-T I.430, chapter 8.5.1.1b): 'When transmitting a binary zero, the output impedance shall be > 20 Ω.': Must be met by external circuitry.
- 3) Requirement ITU-T I.430, chapter 8.5.1.1b), Note: 'The output impedance limit shall apply for a nominal load impedance (resistive) of 50 Ω. The output impedance for each nominal load shall be defined by determining the peak pulse amplitude for loads equal to the nominal value +/- 10%. The peak amplitude shall be defined as the the amplitude at the midpoint of a pulse. The limitation applies for pulses of both polarities.'

Table 35 U-Transceiver Characteristics

	Limit Values			Unit
	min.	typ.	max.	
Receive Path				
Signal / (noise + total harmonic distortion) ¹⁾	65 ²⁾			dB
DC-level at AD-output	45	50	55	% ³⁾
Threshold of level detect (measured between AIN and BIN with respect to zero signal)	10		23	mV peak
Input impedance AIN/BIN	80			kΩ
Transmit Path				
Signal / (noise + total harmonic distortion) ⁴⁾	70			dB
Common mode DC-level	1.61	1.65	1.69	V
Offset between AOUT and BOUT			35	mV
Absolute peak voltage for a single +3 or -3 pulse measured between AOUT and BOUT ⁵⁾	2.42	2.5	2.58	V
Output impedance AOUT/BOUT:				
Power-up		0.8	1.5	Ω
Power-down		3	6	Ω

- 1) Test conditions: 1.4 Vpp differential sine wave as input on AIN/BIN with long range (low, critical range).
- 2) Versions PEF 8x913 with enhanced performance of the U-interface are tested with tightened limit values
- 3) The percentage of the "1"-values in the PDM-signal.
- 4) Interpretation and test conditions: The sum of noise and total harmonic distortion, weighted with a low pass filter 0 to 80 kHz, is at least 70 dB below the signal for an evenly distributed but otherwise random sequence of +3, +1, -1, -3.
- 5) The signal amplitude measured over a period of 1 min. varies less than 1%.

Electrical Characteristics

5.3 Capacitances

$T_A = 25\text{ }^\circ\text{C}$, $3.3\text{ V} \pm 5\%$ $V_{SSA} = 0\text{ V}$, $V_{SSD} = 0\text{ V}$, $f_c = 1\text{ MHz}$, unmeasured pins grounded.

Table 36 Pin Capacitances

Parameter	Symbol	Limit Values		Unit	Remarks
		min.	max.		
Digital pads: Input Capacitance	C_{IN}		7	pF	
I/O Capacitance	$C_{I/O}$		7	pF	
Analog pads: Load Capacitance	C_L		3	pF	pin AIN, BIN

5.4 Power Consumption

Power Consumption

$V_{DD}=3.3\text{ V}$, $V_{SS}=0\text{ V}$, Inputs at V_{SS}/V_{DD} , no LED connected, 50% bin. zeros, no output loads except SX1,2 ($50\text{ }\Omega^1$)

Parameter	Limit Values			Unit	Test Condition
	min.	typ.	max.		
Operational U and S enabled, IOM [®] -2 off		185		mW	U: ETSI loop 1 (0 m)
		165		mW	U: ETSI Loop 2.(typical line)
Power Down		15		mW	

¹⁾ $50\text{ }\Omega$ (2 x TR) on the S-bus.

5.5 Supply Voltages

$V_{DD_D} = + V_{dd} \pm 5\%$

$V_{DD_A} = + V_{dd} \pm 5\%$

The maximum sinusoidal ripple on VDD is specified in the following figure:

Electrical Characteristics

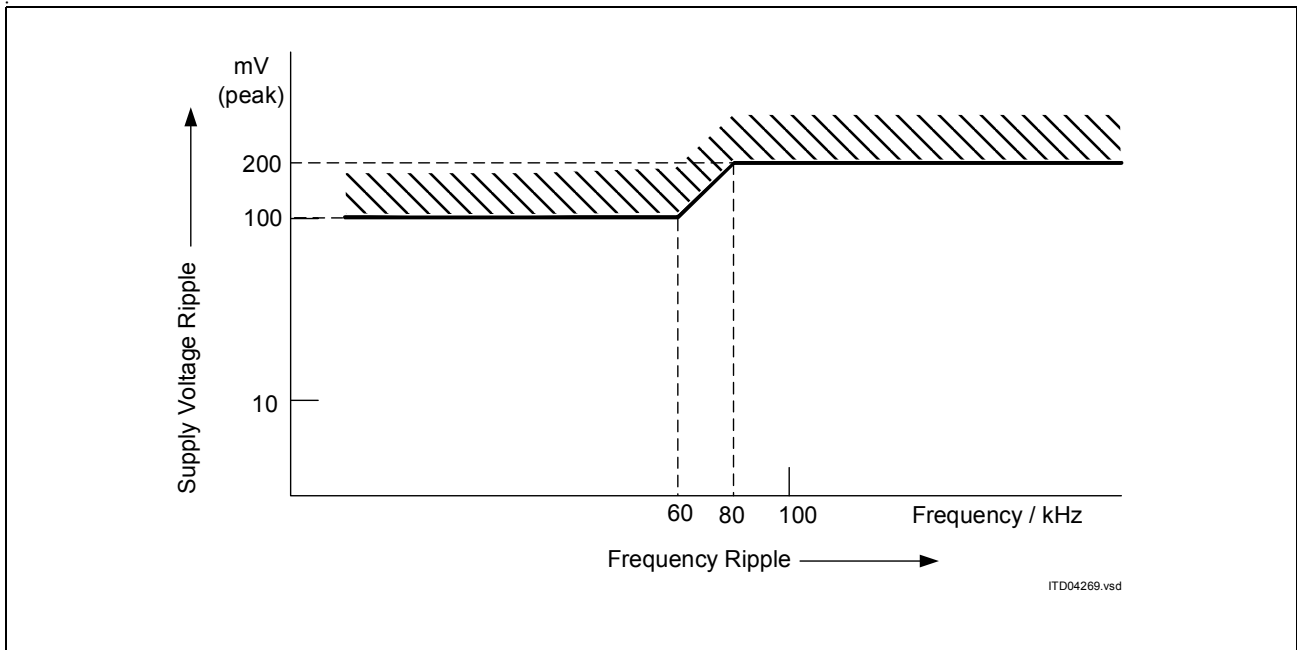

Figure 60 Maximum Sinusoidal Ripple on Supply Voltage

5.6 AC Characteristics

$T_A = -40$ to $85\text{ }^\circ\text{C}$, $V_{DD} = 3.3\text{ V} \pm 5\%$

Inputs are driven to 2.4 V for a logical "1" and to 0.4 V for a logical "0". Timing measurements are made at 2.0 V for a logical "1" and 0.8 V for a logical "0". The AC testing input/output waveforms are shown in **Figure 61**.

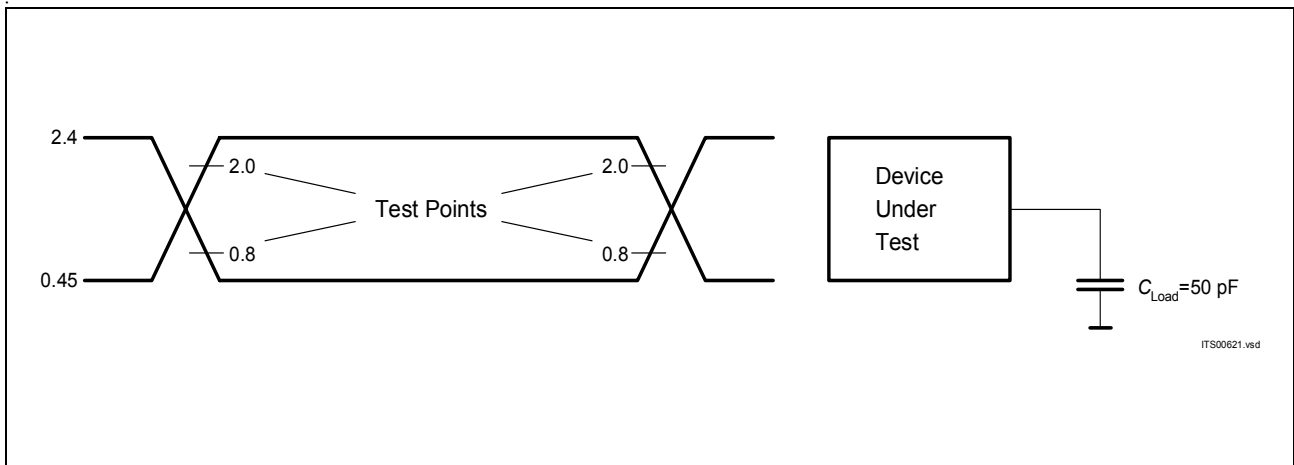
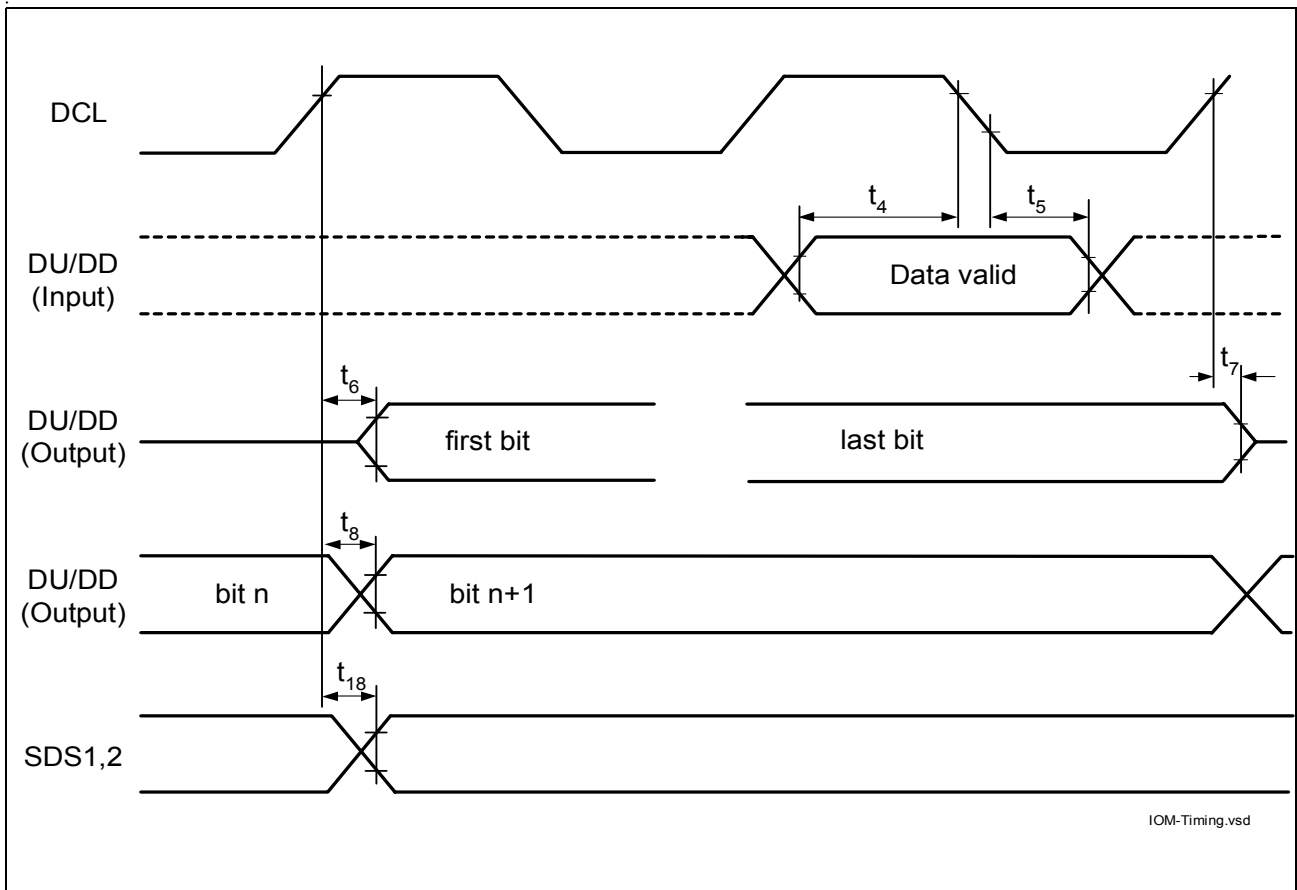

Figure 61 Input/Output Waveform for AC Tests

Parameter	Symbol	Limit values		Unit
		Min	Max	
All Output Pins				
Fall time			30	ns
Rise time			30	ns

5.6.1 IOM[®]-2 Interface



IOM-Timing.vsd

Figure 62 IOM[®]-2 Interface - Bit Synchronization Timing

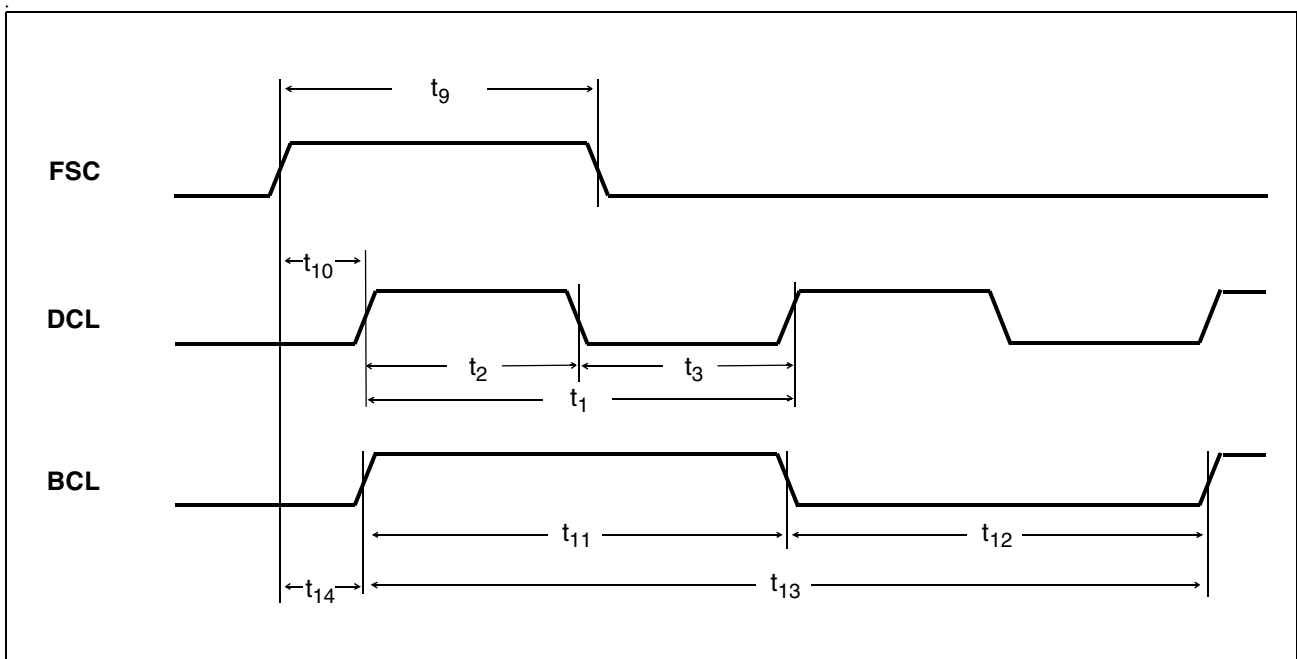

Figure 63 IOM[®]-2 Interface - Frame Synchronization Timing

Electrical Characteristics

Parameter IOM [®] -2 Interface	Symbol	Limit values			Unit
		Min	Typ	Max	
DCL period	t_1	565	651	735	ns
DCL high	t_2	200	310	420	ns
DCL low	t_3	200	310	420	ns
Input data setup	t_4	20			ns
Input data hold	t_5	20			ns
Output data from high impedance to active (FSC high or other than first timeslot)	t_6			100	ns
Output data from active to high impedance	t_7			100	ns
Output data delay from clock	t_8			80	ns
FSC high	t_9		50% of FSC cycle time		ns
FSC advance to DCL	t_{10}	65	130	195	ns
BCL high	t_{11}	565	651	735	ns
BCL low	t_{12}	565	651	735	ns
BCL period	t_{13}	1130	1302	1470	ns
FSC advance to BCL	t_{14}	65	130	195	ns
DCL, FSC rise/fall	t_{15}			30	ns
Data out fall ($C_L = 50$ pF, $R = 2$ k Ω to V_{DD} , open drain)	t_{16}			200	ns
Data out rise/fall ($C_L = 50$ pF, tristate)	t_{17}			150	ns
Strobe Signal Delay	t_{18}			120	ns

Note: At the start and end of a reset period, a frame jump may occur. This results in a DCL, BCL and FSC high time of min. 130 ns after this specific event.

5.6.2 Serial μ P Interface

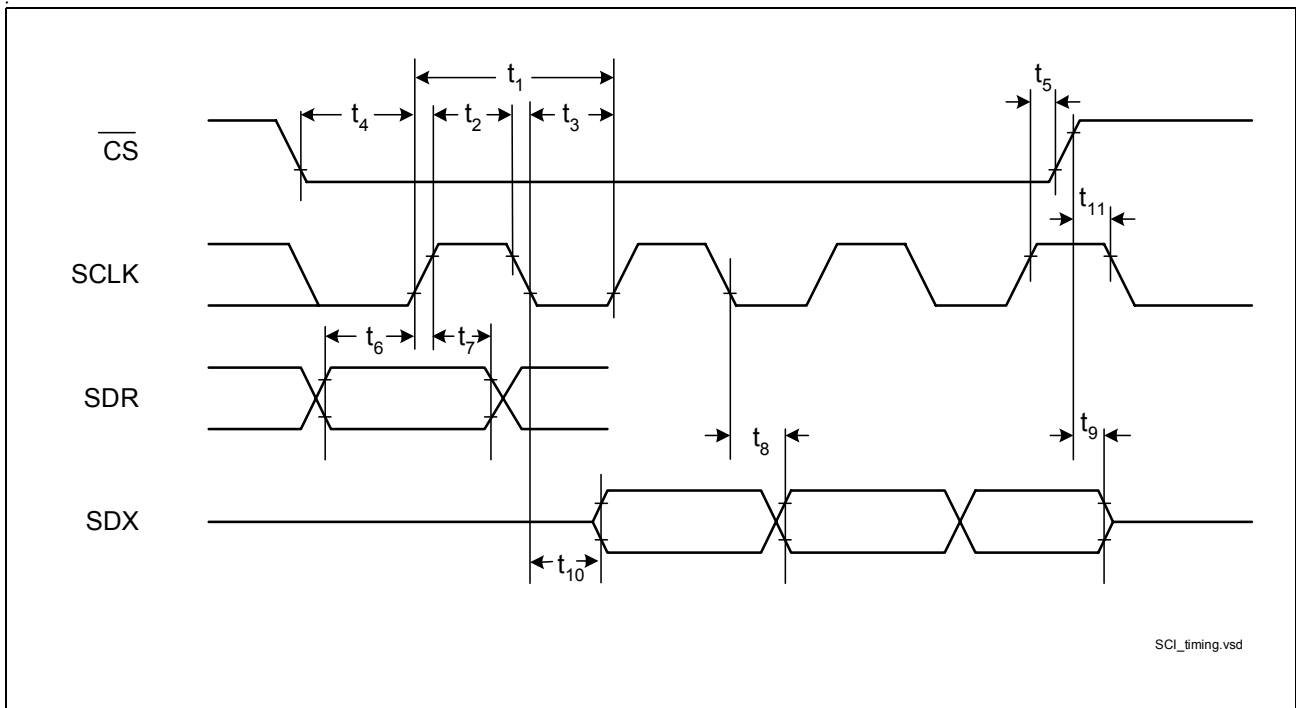

SCI_timing.vsd

Figure 64 Serial Control Interface

Parameter SCI Interface	Symbol	Limit values		Unit
		Min	Max	
SCLK cycle time	t_1	200		ns
SCLK high time	t_2	80		ns
SCLK low time	t_3	80		ns
\overline{CS} setup time	t_4	20		ns
\overline{CS} hold time	t_5	10		ns
SDR setup time	t_6	15		ns
SDR hold time	t_7	15		ns
SDX data out delay	t_8		60	ns
\overline{CS} high to SDX tristate	t_9		40	ns
SCLK to SDX active	t_{10}		60	ns
\overline{CS} high to SCLK	t_{11}	10		ns

5.6.3 Parallel μ P Interface

Siemens/Intel Bus Mode

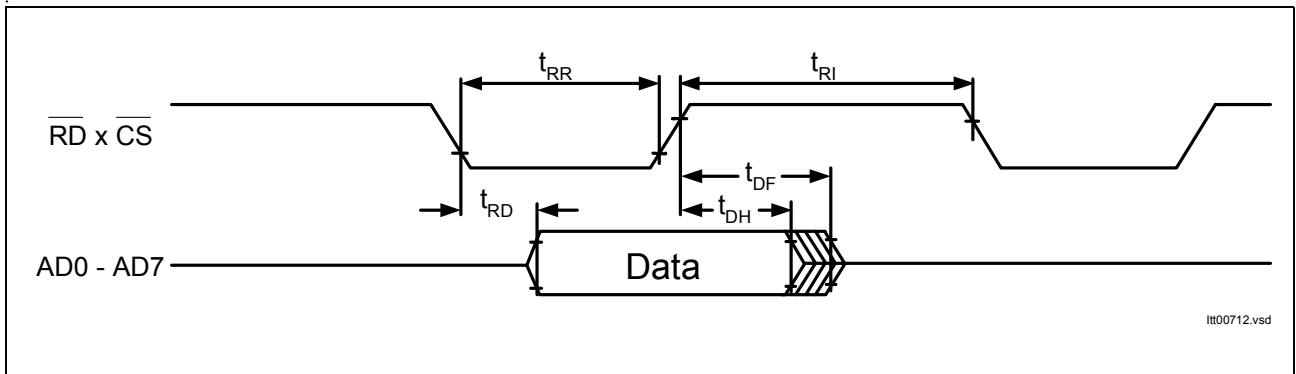

Figure 65 Microprocessor Read Cycle

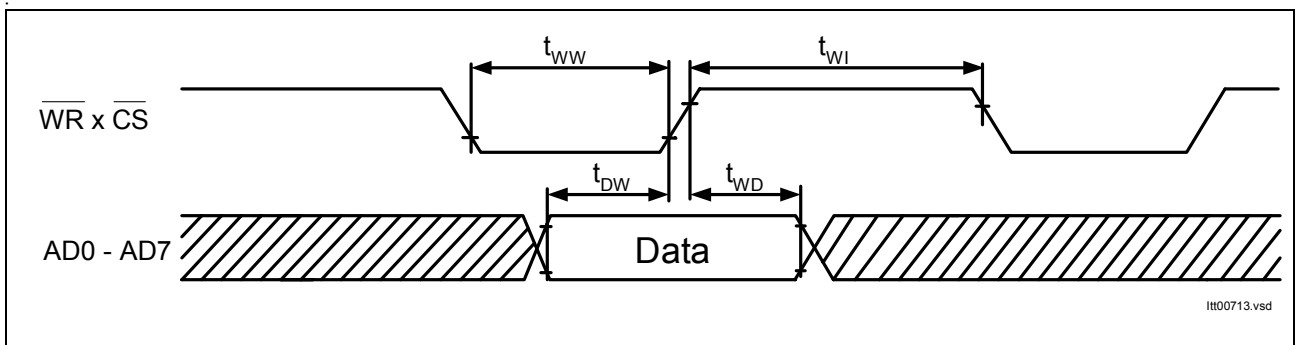

Figure 66 Microprocessor Write Cycle

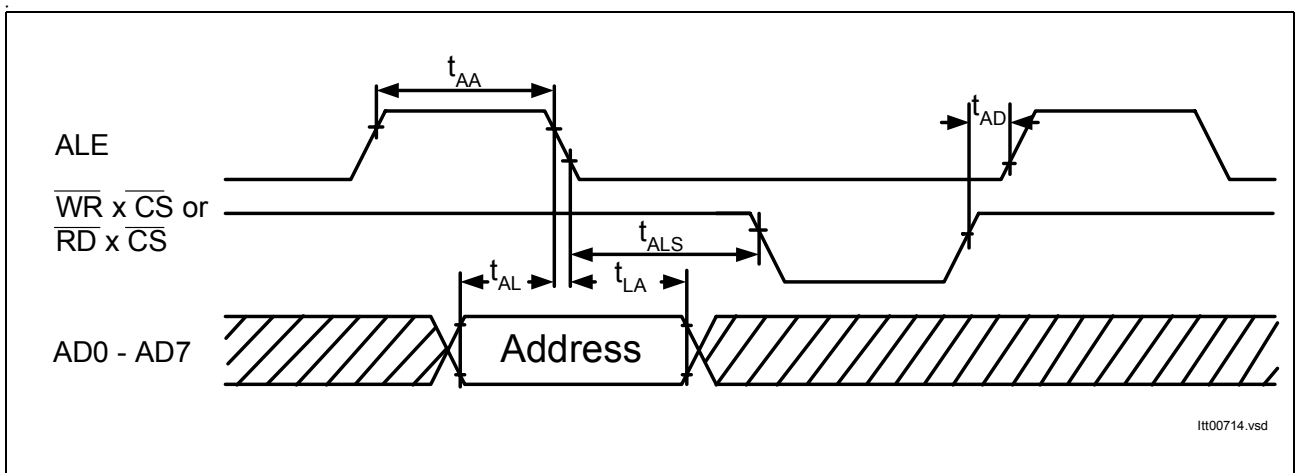

Figure 67 Multiplexed Address Timing

Electrical Characteristics

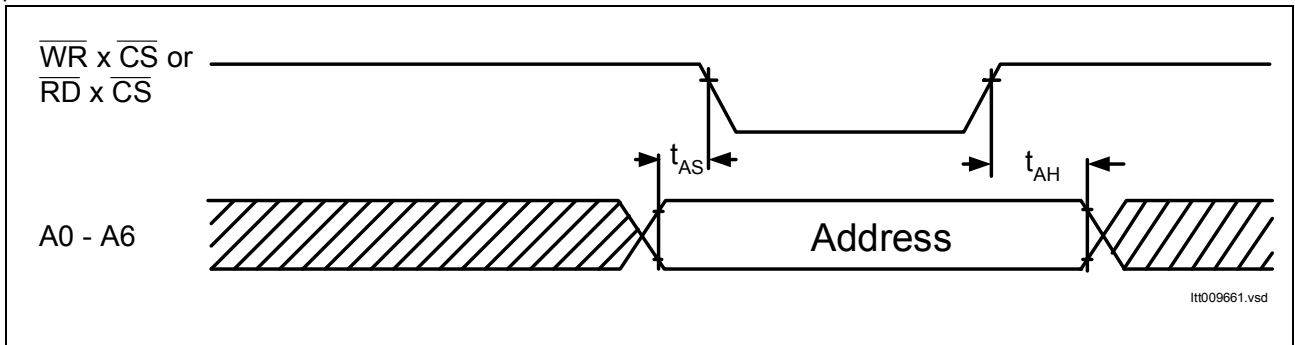

Figure 68 Non-Multiplexed Address Timing

Motorola Bus Mode

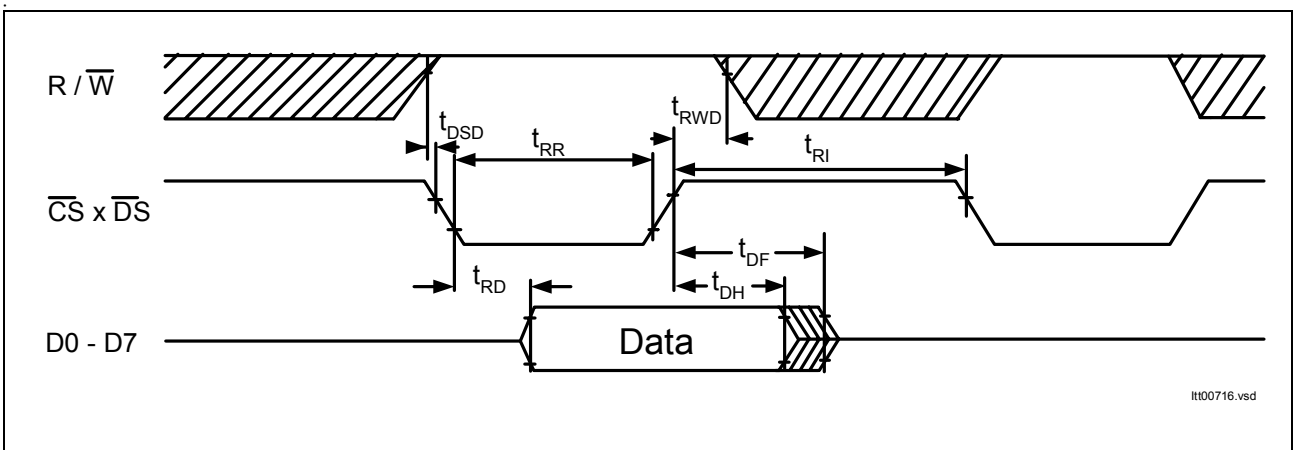

Figure 69 Microprocessor Read Timing

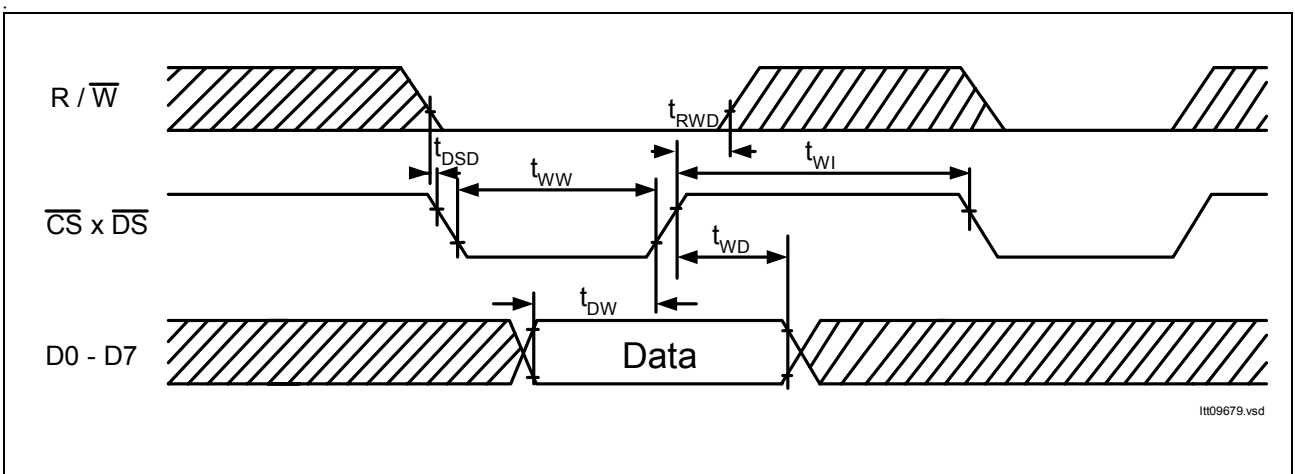

Figure 70 Microprocessor Write Cycle

Electrical Characteristics

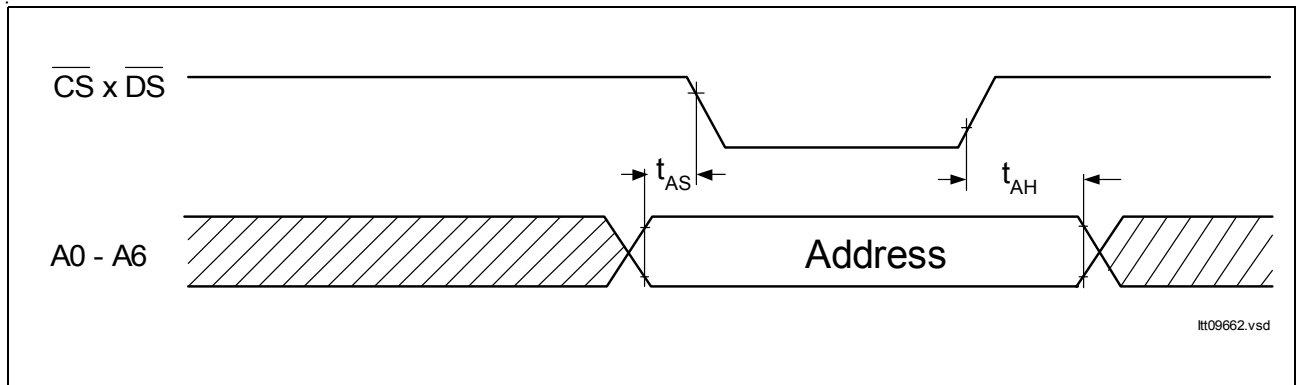

Figure 71 Non-Multiplexed Address Timing

Microprocessor Interface Timing

Parameter	Symbol	Limit Values		Unit
		min.	max.	
ALE pulse width	t_{AA}	20		ns
Address setup time to ALE	t_{AL}	10		ns
Address hold time from ALE	t_{LA}	10		ns
Address latch setup time to \overline{WR} , \overline{RD}	t_{ALS}	10		ns
Address setup time	t_{AS}	10		ns
Address hold time	t_{AH}	10		ns
ALE guard time	t_{AD}	10		ns
\overline{DS} delay after R/\overline{W} setup	t_{DSD}	10		ns
\overline{RD} pulse width	t_{RR}	80		ns
Data output delay from \overline{RD}	t_{RD}		80	ns
Data hold from \overline{RD}	t_{DH}	0		ns
Data float from \overline{RD}	t_{DF}		25	ns
\overline{RD} control interval ¹⁾	t_{RI}	70		ns
\overline{W} pulse width	t_{WW}	60		ns
Data setup time to $\overline{W} \times \overline{CS}$	t_{DW}	10		ns
Data hold time $\overline{W} \times \overline{CS}$	t_{WD}	10		ns
\overline{W} control interval	t_{WI}	70		ns
R/\overline{W} hold from $\overline{CS} \times \overline{DS}$ inactive	t_{RWD}	10		ns

Electrical Characteristics

- 1) control interval: t_{RI} is minimal 70ns for all registers except ISTAU, FEBE and NEBE. However, the time between two consecutive read accesses to one of the registers ISTAU, FEBE or NEBE, respectively, must be longer than 330ns. This does not limit t_{RI} of read sequences, which involve intermediate read access to other registers, as for instance: ISTAU $-(t_{RI})$ - ISTA $-(t_{RI})$ - ISTAH $-(t_{RI})$ - ISTAU.

5.6.4 Reset

Table 37 Reset Input Signal Characteristics

Parameter	Symbol	Limit Values			Unit	Test Conditions
		min.	typ.	max.		
Length of active low state	$t_{\overline{RST}}$	4			ms	Power On the 4 ms are assumed to be long enough for the oscillator to run correctly
		2 x DCL clock cycles + 400 ns				After Power On
Delay time for μC access after \overline{RST} rising edge	$t_{\mu C}$	500			ns	

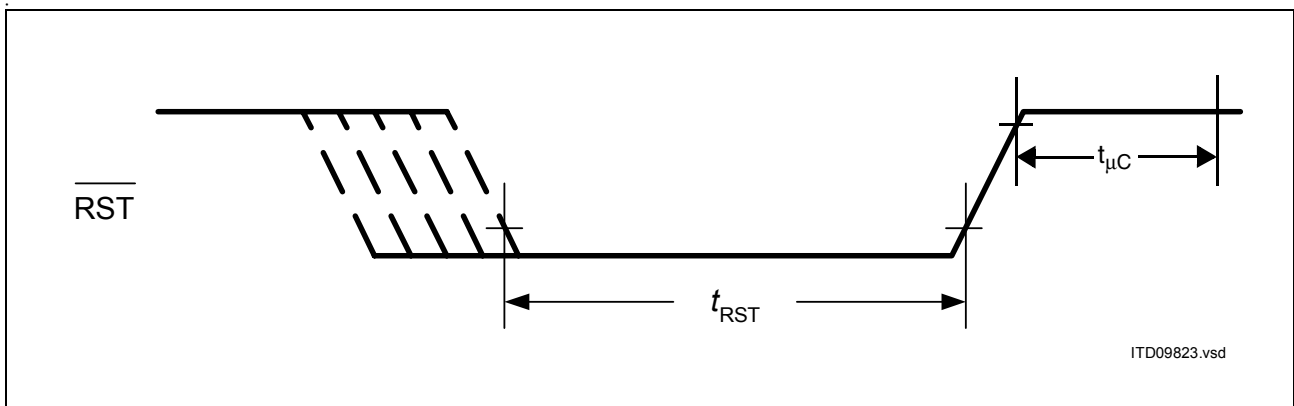

Figure 72 Reset Input Signal

5.6.5 Undervoltage Detection Characteristics

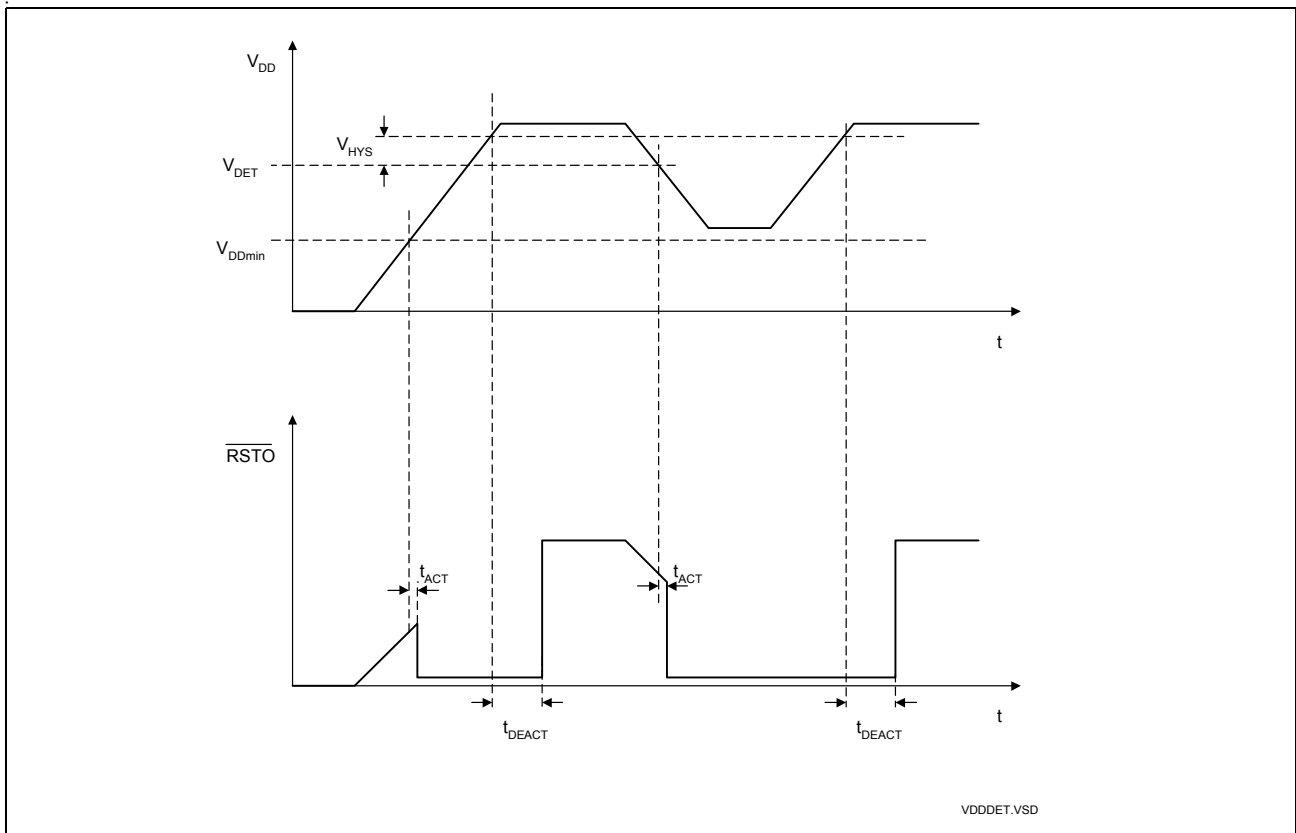

Figure 73 Undervoltage Control Timing

Table 38 Parameters of the UVD/POR Circuit

$V_{DD} = 3.3\text{ V} \pm 5\%$; $V_{SS} = 0\text{ V}$; $T_A = -40\text{ to }85\text{ }^\circ\text{C}$

Parameter	Symbol	Limit Values			Unit	Test Condition
		min.	typ.	max.		
Detection Threshold ¹⁾	V_{DET}	2.7	2.8	2.92	V	$V_{DD} = 3.3\text{ V} \pm 5\%$
Hysteresis	V_{Hys}	30		90	mV	
Max. rising/falling V_{DD} edge for activation/deactivation of UVD	dV_{DD}/dt			0.1	V/ μs	
Max. rising V_{DD} for power-on ²⁾				0.1	V/ms	
Min. operating voltage	V_{DDmin}	1.5			V	

Electrical Characteristics

$V_{DD} = 3.3\text{ V} \pm 5\%$; $V_{SS} = 0\text{ V}$; $T_A = -40\text{ to }85\text{ }^\circ\text{C}$

Parameter	Symbol	Limit Values			Unit	Test Condition
		min.	typ.	max.		
Delay for activation of $\overline{\text{RSTO}}$	t_{ACT}			10	μs	
Delay for deactivation of $\overline{\text{RSTO}}$	t_{DEACT}		64		ms	

- 1) The Detection Threshold V_{DET} is far below the specified supply voltage range of analog and digital parts of the T-SMINT[®]. Therefore, the board designer must take into account that a range of voltages is existing, where neither performance and functionality of the T-SMINT[®] are guaranteed, nor a reset is generated.
- 2) If the integrated Power-On Reset of the T-SMINTI is selected ($\overline{\text{VDDDET}} = '0'$) and the supply voltage V_{DD} is ramped up from 0V to 3.3V +/- 5%, then the T-SMINTI is kept in reset during $V_{\text{DDmin}} < V_{\text{DD}} < V_{\text{DET}} + V_{\text{Hys}}$. V_{DD} must be ramped up so slowly that the T-SMINTI leaves the reset state after the oscillator circuit has already finished start-up. The start-up time of the oscillator circuit is typically in the range between 3ms and 12ms.

Plastic Package, P-TQFP-64
(Thin Quad Flat Package)

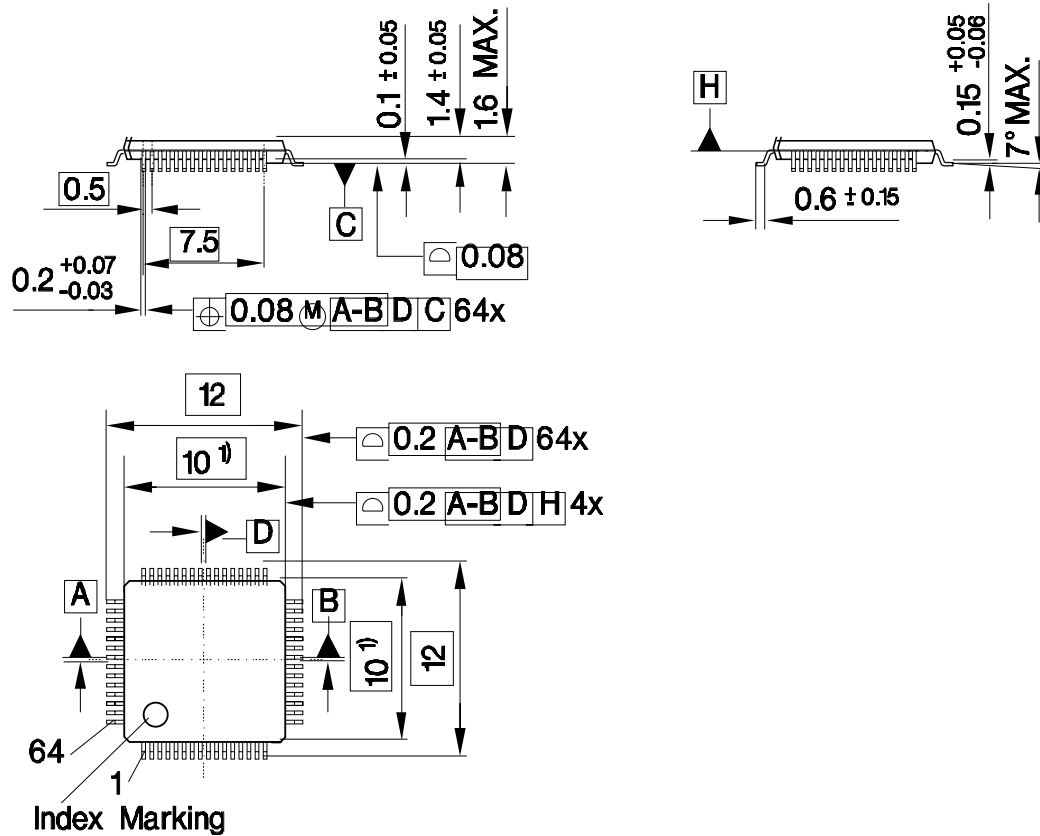

1) Does not include plastic or metal protrusion of 0.25 max. per side

Appendix: Differences between Q- and T-SMINT,I

7 Appendix: Differences between Q- and T-SMINT[®]I

The Q- and T-SMINT[®]I have been designed to be as compatible as possible. However, some differences between them are unavoidable due to the different line codes 2B1Q and 4B3T used for data transmission on the U_{k0} line.

Especially the pin compatibility between Q- and T-SMINT[®]I allows for one single PCB design for both series with only some mounting differences. The μC software can distinguish between the Q- and T-series by reading the hardware Design Number via the IOM[®]-2 (MONITOR channel identification command) or the μC interface (register ID.DESIGN), respectively (see [Table 39](#)).

Table 39 Design Number

	Design Number	
	Q-SMINT [®] I: 2B1Q	T-SMINT [®] I: 4B3T
Version	Version 1.3: '000 001'	Version 1.1: '100 000'

The following chapter summarizes the main differences between the Q- and T-SMINT[®]I.

Appendix: Differences between Q- and T-SMINT,I

7.1 Pinning

7.1.1 Pin Definitions and Functions

Table 40 Pin Definitions and Functions

	Pin T/MQFP-64	Q-SMINT [®] I: 2B1Q	T-SMINT [®] I: 4B3T
	16	Metallic Termination Input (MTI)	Tie to '1'
	55	Power Status (primary) (PS1)	Tie to '1'
	41	Power Status (secondary) (PS2)	Tie to '1'

7.1.2 LED Pin $\overline{\text{ACT}}$

The 4 LED states (off, fast flashing, slow flashing, on), which can be displayed with pin $\overline{\text{ACT}}$, are slightly different for Q- and T-SMINT[®]I (see [Table 41](#)). This adoption guarantees full compliance of T-SMINT[®]I to the new iNT specification TS 0284/96.

Table 41 $\overline{\text{ACT}}$ States

LED States	Pin $\overline{\text{ACT}}$	
	Q-SMINT [®] I: 2B1Q	T-SMINT [®] I: 4B3T
off	V _{DD}	V _{DD}
fast flashing	8Hz (1 : 1)*	2Hz (1 : 1)*
slow flashing	1Hz (1 : 1)*	1Hz (3 : 1)*
on	GND	GND

Note: * denotes the duty cycle 'high' : 'low'.

Appendix: Differences between Q- and T-SMINT,I

7.2 U-Transceiver

7.2.1 U-Interface Conformity

Table 42 Related Documents to the U-Interface

	Q-SMINT [®] I: 2B1Q	T-SMINT [®] I: 4B3T
ETSI: TS 102 080	conform to annex A compliant to 10 ms interruptions	conform to annex B
ANSI: T1.601-1998 (Revision of ANSI T1.601- 1992)	conform MLT input and decode logic	not required
CNET: ST/LAA/ELR/DNP/ 822	conform	not required
RC7355E	conform	not required
FTZ-Richtlinie 1 TR 220	not required	conform
FTZ TS 0284/96 'Intelligenter Netzabschluss (iNT)' März 2001	not required	conform

Appendix: Differences between Q- and T-SMINT, I

7.2.2 U-Transceiver State Machines

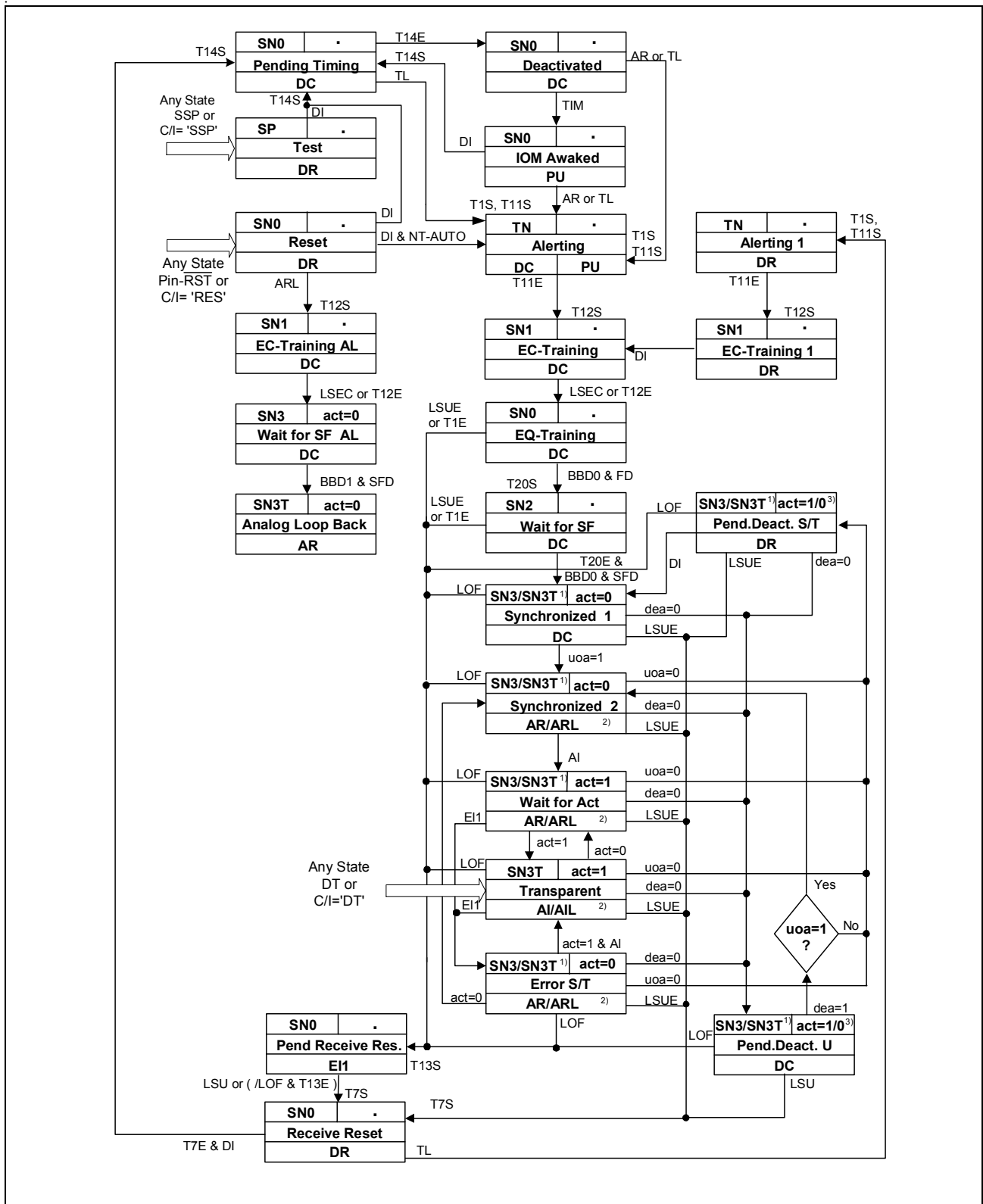

Figure 74 NTC-Q Compatible State Machine Q-SMINT® I: 2B1Q

Appendix: Differences between Q- and T-SMINT,I

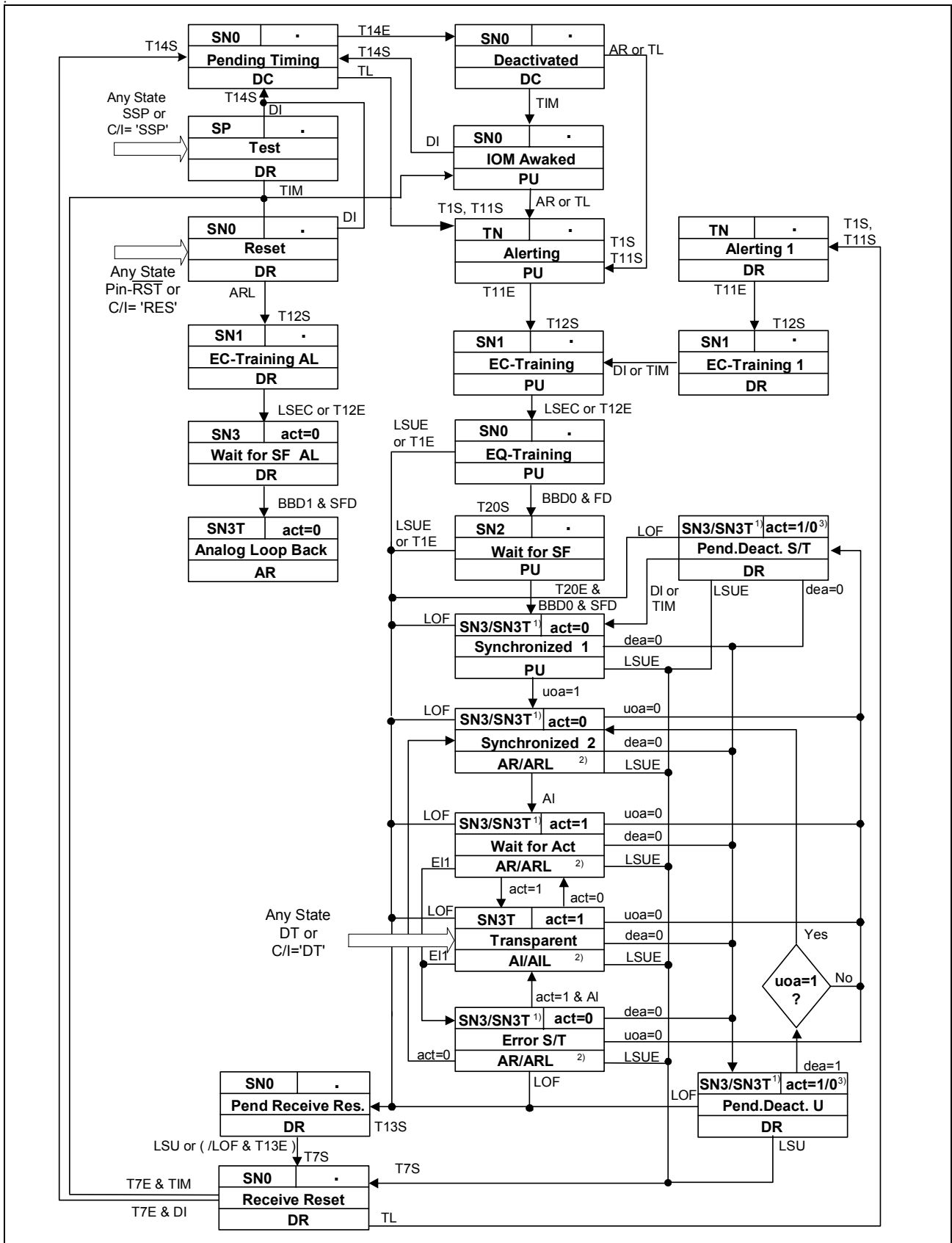
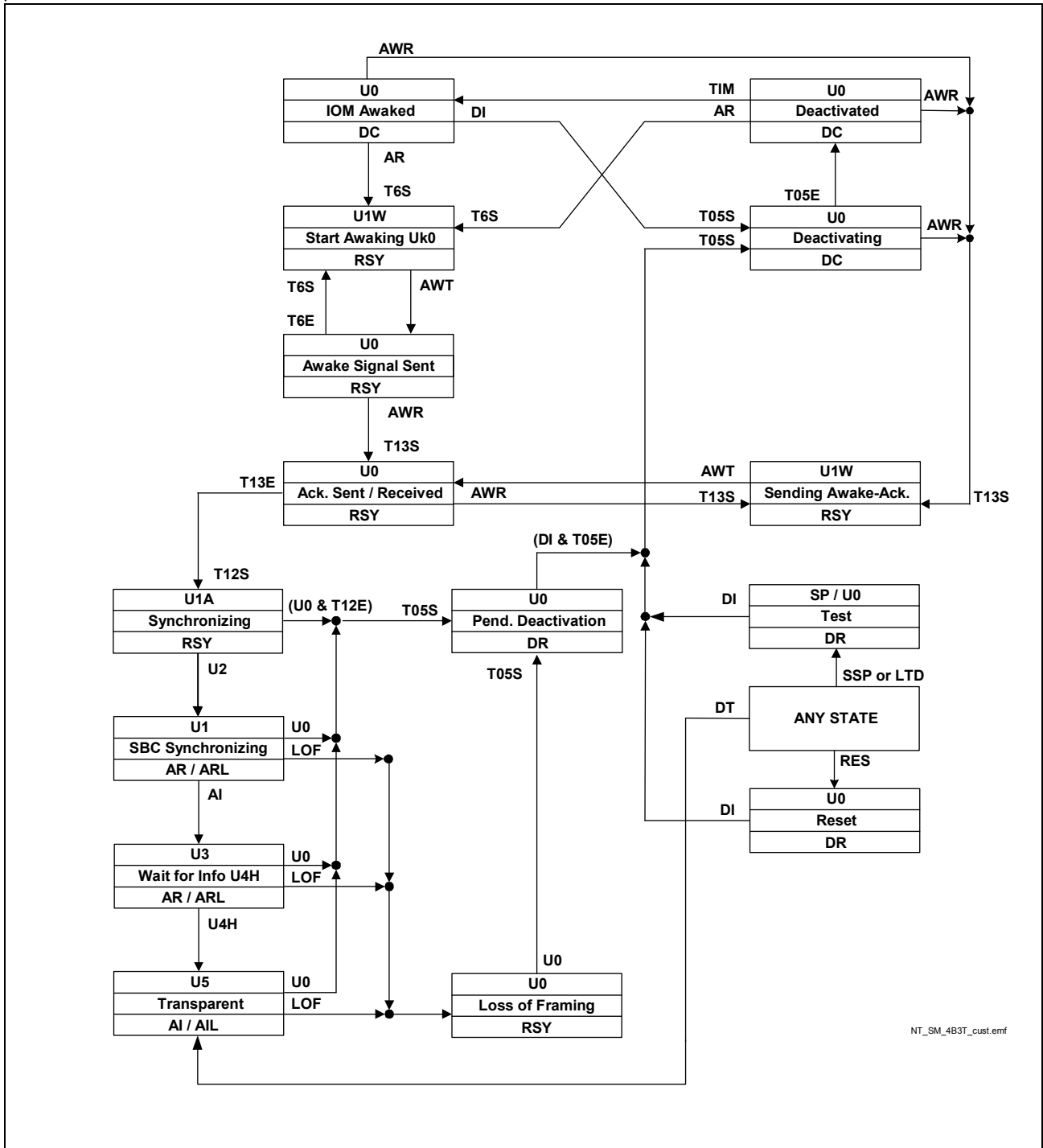

Figure 75 Simplified State Machine Q-SMINT® I: 2B1Q

Appendix: Differences between Q- and T-SMINT,I



NT_SM_4B3T_cust.emf

Figure 76 IEC-T/NTC-T Compatible State Machine T-SMINT® I: 4B3T

Both the Q- and the T-SMINT® I U-transceiver can be controlled via state machines, which are compatible to those defined for the old NT generation INTC-Q and NTC-T. Additionally, the Q-SMINT® I possesses a newly defined, so called 'simplified' state machine. This simplified state machine can be used optionally instead of the INTC-Q compatible state machine and eases the U-transceiver control by software. Such a simplified state machine is not available for the T-SMINT® I.

Appendix: Differences between Q- and T-SMINT,I

7.2.3 Command/Indication Codes

Table 43 C/I Codes

Code	Q-SMINT [®] I: 2B1Q		T-SMINT [®] I: 4B3T	
	IN	OUT	IN	OUT
0000	TIM	DR	TIM	DR
0001	RES	–	–	–
0010	–	–	–	–
0011	–	–	LTD	–
0100	EI1	EI1	–	RSY
0101	SSP	–	SSP	–
0110	DT	–	DT	–
0111	–	PU	–	–
1000	AR	AR	AR	AR
1001	–	–	–	–
1010	ARL	ARL	–	ARL
1011	–	–	–	–
1100	AI	AI	AI	AI
1101	–	–	RES	–
1110	–	AIL	–	AIL
1111	DI	DC	DI	DC

Appendix: Differences between Q- and T-SMINT,I

7.2.4 Interrupt Structure

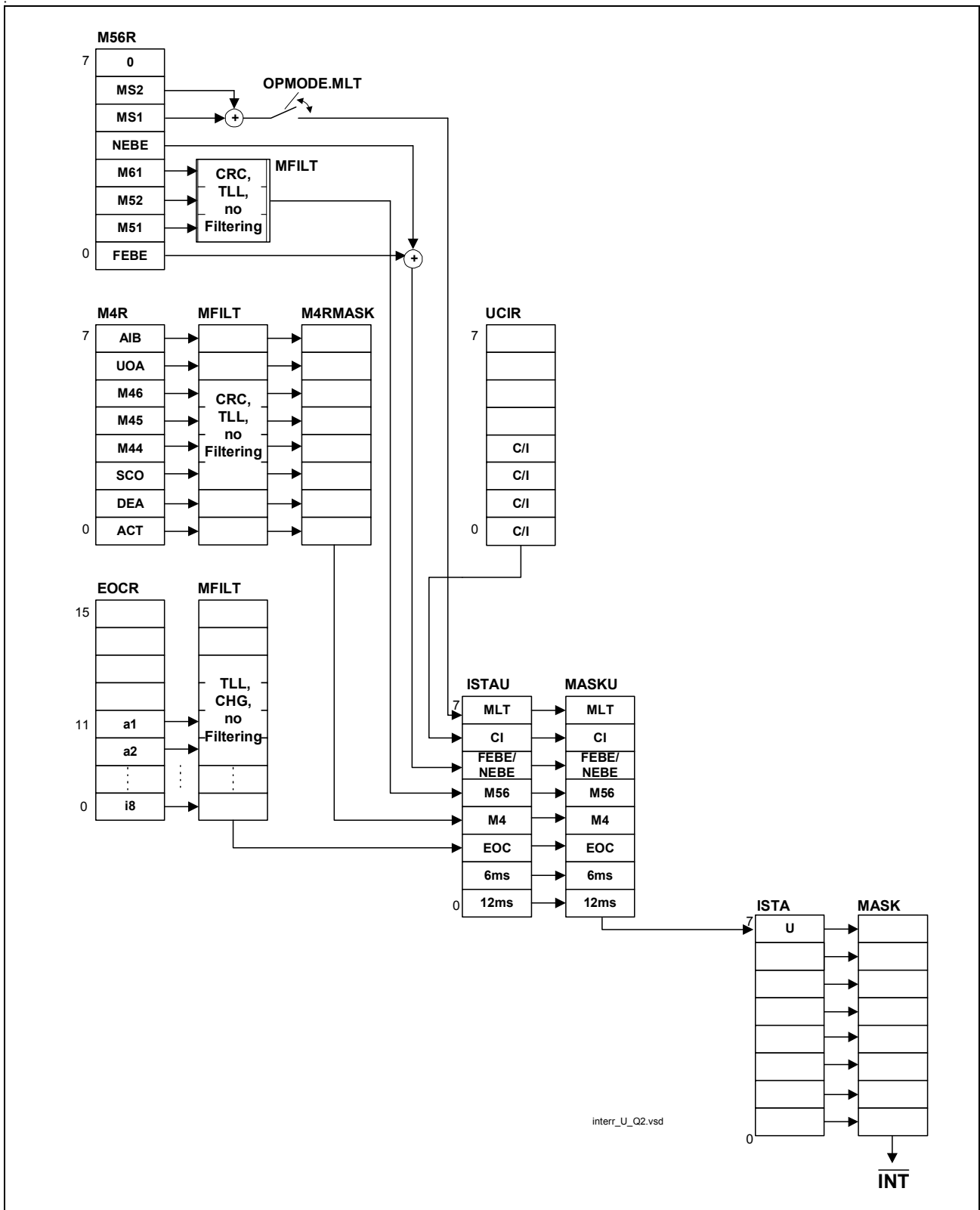

Figure 77 Interrupt Structure U-Transceiver Q-SMINT® I: 2B1Q

Appendix: Differences between Q- and T-SMINT,I

7.2.5 Register Summary U-Transceiver

U-Interface Registers Q-SMINT®I: 2B1Q

Name	7	6	5	4	3	2	1	0	ADDR	R/W	RES
OPMODE	0	UCI	FEBE	MLT	0	CI_SEL	0	0	60 _H	R*/W	14 _H
MFILT	M56 FILTER		M4 FILTER			EOC FILTER			61 _H	R*/W	14 _H
	reserved								62 _H		
EOCR	0	0	0	0	a1	a2	a3	d/m	63 _H	R	0F
	i1	i2	i3	i4	i5	i6	i7	i8	64 _H		FF _H
EOCW	0	0	0	0	a1	a2	a3	d/m	65 _H	W	01 _H
	i1	i2	i3	i4	i5	i6	i7	i8	66 _H		00 _H
M4RMASK	M4 Read Mask Bits								67 _H	R*/W	00 _H
M4WMASK	M4 Write Mask Bits								68 _H	R*/W	A8 _H
M4R	verified M4 bit data of last received superframe								69 _H	R	BE _H
M4W	M4 bit data to be send with next superframe								6A _H	R*/W	BE _H
M56R	0	MS2	MS1	NEBE	M61	M52	M51	FEBE	6B _H	R	1F _H
M56W	1	1	1	1	M61	M52	M51	FEBE	6C _H	W	FF _H
UCIR	0	0	0	0	C/I code output				6D _H	R	00 _H
UCIW	0	0	0	0	C/I code input				6E _H	W	01 _H
TEST	0	0	0	0	CCRC	+1 Tones	0	40 KHz	6F _H	R*/W	00 _H
LOOP	0	DLB	TRANS	U/IOM®	1	LBBD	LB2	LB1	70 _H	R*/W	08 _H
FEBE	FEBE Counter Value								71 _H	R	00 _H
NEBE	NEBE Counter Value								72 _H	R	00 _H
	reserved								73 _H - 79 _H		

Appendix: Differences between Q- and T-SMINT,I

Name	7	6	5	4	3	2	1	0	ADDR	R/W	RES
ISTAU	MLT	CI	FEBE/ NEBE	M56	M4	EOC	6ms	12ms	7A _H	R	00 _H
MASKU	MLT	CI	FEBE/ NEBE	M56	M4	EOC	6ms	12ms	7B _H	R*/W	FF _H
	reserved								7C _H		
FW_ VERSION	FW Version Number								7D _H	R	6x _H
	reserved								7E _H - 7F _H		

Appendix: Differences between Q- and T-SMINT,I

U-Interface Registers T-SMINT®I: 4B3T

Name	7	6	5	4	3	2	1	0	ADDR	R/W	RES
OPMODE	0	UCI	0	0	0	0	0	0	60 _H	R*/W	00 _H
	reserved								61 _H - 6C _H		
UCIR	0	0	0	0	C/I code output				6D _H	R	00 _H
UCIW	0	0	0	0	C/I code input				6E _H	W	01 _H
LOOP	reserved								6F _H		
	0	0	TRANSU/IOM®	1	LBBD	LB2	LB1		70 _H	R*/W	08 _H
RDS	reserved								71 _H		
	Block Error Counter Value								72 _H	R	00 _H
ISTAU	reserved								73 _H - 79 _H		
	0	CI	RDS	0	0	0	0	1 ms	7A _H	R	00 _H
MASKU	1	CI	RDS	1	1	1	1	1 ms	7B _H	R*/W	FF _H
	reserved								7C _H		
FW_VERSION	FW Version Number								7D _H	R	3x _H
	reserved								7E _H - 7F _H		

Appendix: Differences between Q- and T-SMINT,I

7.3 External Circuitry

The external circuitry of the Q- and T-SMINT®I is equivalent; however, some external components of the U-transceiver hybrid must be dimensioned different for 2B1Q and 4B3T. All information on the external circuitry is preliminary and may be changed in future documents.

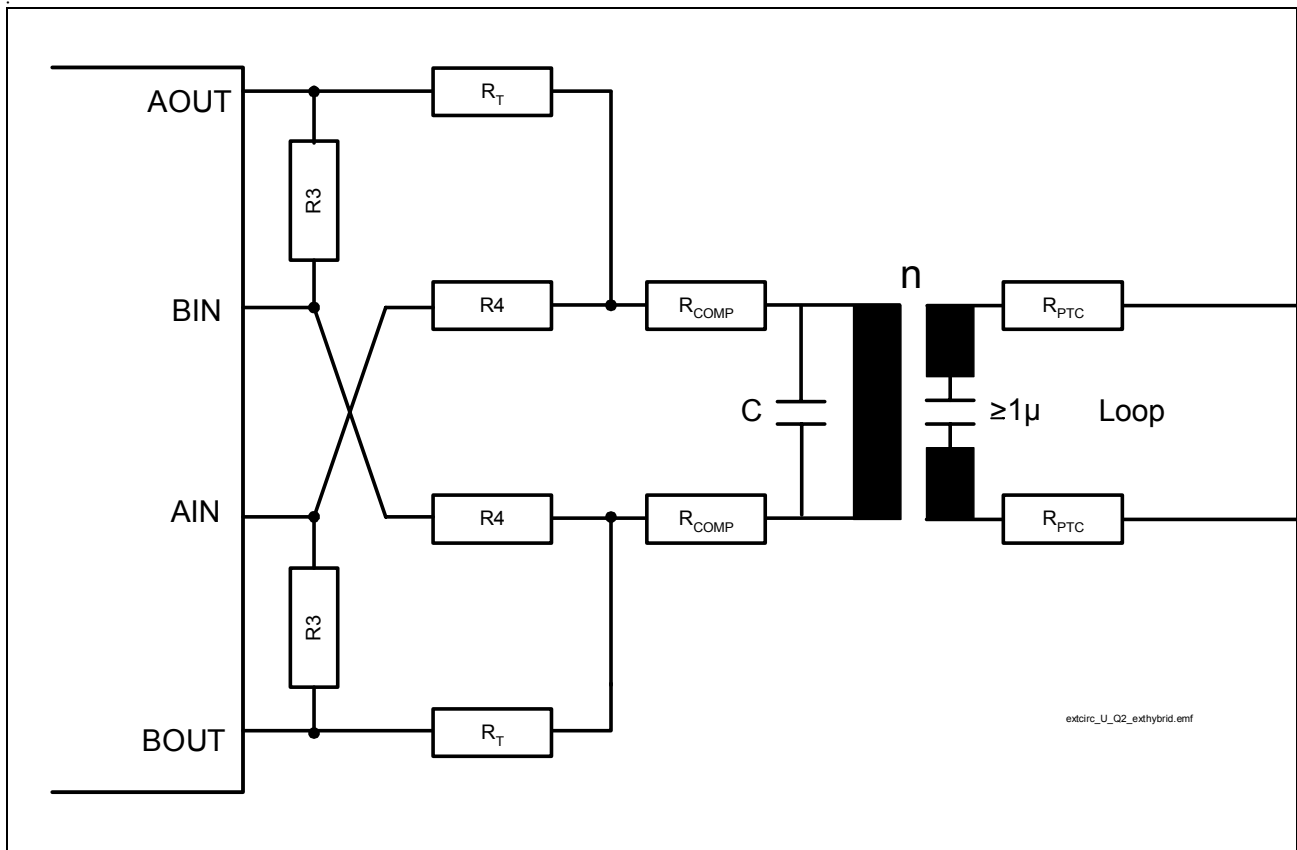

Figure 79 External Circuitry Q- and T-SMINT®I

Note: the necessary protection circuitry is not displayed in [Figure 79](#).

Table 44 Dimensions of External Components

Component	Q-SMINT®I: 2B1Q	T-SMINT®I: 4B3T
Transformer: Ratio	1:2	1:1.6
Main Inductivity	14.5 mH	7.5 mH
Resistance	1.3 k Ω	1.75 k Ω
Resistance	1.0 k Ω	1.0 k Ω
Resistance	9.5 Ω	25 Ω
Capacitor C	27 nF	15 nF
R_{PTC} and R_{Comp}	$2R_{PTC} + 8R_{Comp} = 40 \Omega$	$n^2 \times (2R_{COMP} + R_B) + R_L = 20\Omega$

8 Index

A

Absolute Maximum Ratings 160
Address Space 114

B

Block Diagram 6
Block Error Counter 65

C

C/I Channel
 Detailed Registers 124
 Functional Description 49
C/I Codes
 S-Transceiver 85
 U-Transceiver 66
Controller Data Access (CDA) 30

D

DC Characteristics 161
D-Channel Access Control
 Functional Description 51
 State Machine 55
Differences between Q- and T-SMINT 178

E

External Circuitry
 S-Transceiver 110

F

Features 3

I

Identification
 via Monitor Channel 47
 via Register Access 139
Interrupts 114
IOM[®]-2 Interface
 AC Characteristics 166
 Activation/Deactivation 57
 Detailed Registers 140

Frame Structure 27
Functional Description 27

L

Layer 1
 Activation / Deactivation 96
 Loopbacks 104
LED Pins 12
Line Overload Protection 160

M

Maintenance Channel 63
Microcontroller Clock Generation 23
Microcontroller Interfaces
 Interface Selection 16
 Parallel Microcontroller Interface 21
 Serial Control Interface (SCI) 16
Monitor Channel
 Detailed Registers 151
 Error Treatment 45
 Functional Description 41
 Handshake Procedure 41
 Interrupt Logic 48
 Time-Out Procedure 48

O

Oscillator Circuitry 113

P

Package Outlines 176
Parallel Microcontroller Interface
 AC-Characteristics 169
 Functional Description 21
Pin Configuration 5
Pin Definitions and Functions 7
Power Consumption 163
Power Supply Blocking 108
Power-On Reset 26, 174

R

Register Summary 116
Reset
 Generation 23

Input Signal Characteristics 173
Power-On Reset 26, 174
Under Voltage Detection 26, 174

S

S/Q Channels 81
Scrambler / Descrambler 66
Serial Control Interface (SCI)
 AC-Characteristics 168
 Functional Description 16
Serial Data Strobe Signal 40
Stop/Go Bit Handling 53
S-Transceiver
 Detailed Registers 128
 Functional Description 79
 State Machine, LT-S 91
 State Machine, NT 87
Supply Voltages 163
Synchronous Transfer 36
System Integration 13

T

Test Modes 12
TIC Bus Handling 52

U

U-Interface Hybrid 108
Under Voltage Detection 26, 174
U-Transceiver
 4B3T Frame Structure 59
 Detailed Registers 155
 Functional Description 59
 State Machine NT 67

W

Watchdog Timer 25

Infineon goes for Business Excellence

“Business excellence means intelligent approaches and clearly defined processes, which are both constantly under review and ultimately lead to good operating results.

Better operating results and business excellence mean less idleness and wastefulness for all of us, more professional success, more accurate information, a better overview and, thereby, less frustration and more satisfaction.”

Dr. Ulrich Schumacher

<http://www.infineon.com>

Published by Infineon Technologies AG