

NOTES:

- 1 MATERIAL:
 - 1-1 HOUSING: LIQUID CRYSTAL POLYMER(LCP), GLASS FIBER FILLED, UL94 V-0, COLOR: BLACK
 - 1-2 TERMINAL: COPPER ALLOY
- 2 TERMINAL FINISH:
 - 15μ GOLD PLATING ON CONTACT AREA
 - 150μ TIN-LEAD ALLOY ON SOLDER TAIL AREA
 - 50μ NICKEL(Ni) OVERALL
- 3 RECOMMENDED CARD THICKNESS OF CONNECTING AREA: 3.3mm +/- 0.1mm
- 4 RECOMMENDED CARD WIDTH : 42.8mm +/- 0.1mm
- △ THE DIMENSION APPLIES TO CIRCUIT NUMBERS: 1 , 13 , 38 AND 50
- △ THE DIMENSION APPLIES TO OTHER CIRCUIT NUMBERS EXCEPT FOR 1 , 13 , 38 , 50 , 25 , 26
- △ THE DIMENSION APPLIES TO CIRCUIT NUMBERS : 25 AND 26
- 8 PIN DIAMETER IS 0.44±0.02
- 9 TOTAL COPLANARITY OF SOLDER TAILS AND NAILS TO BE 0.10mm MAX
- 10 PRODUCT SPECIFICATION: PS-47026-001
- 11 PACKING METHOD: TUBE

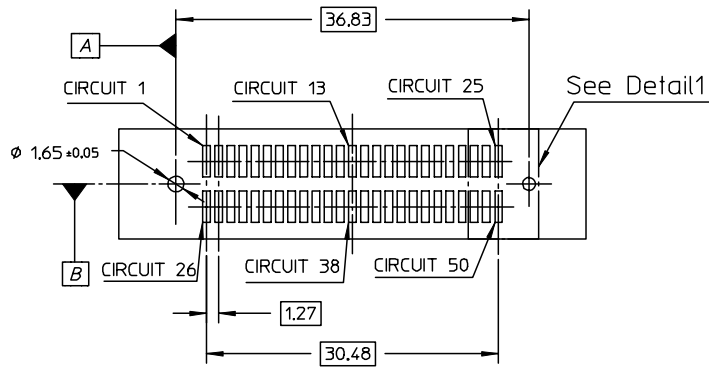
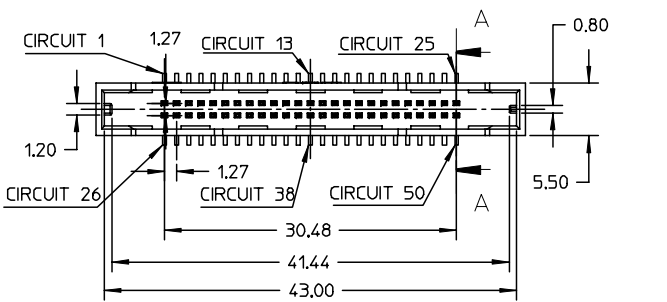

NEW RELEASE EC NO: SH2004-0022 DRWN: XIXU 2003/11/21 CHKD: JLU 2003/11/25 APPR: SHUANG 2003/11/26	DESCRIPTION REV A	QUALITY SYMBOLS	GENERAL TOLERANCES (UNLESS SPECIFIED)	SCALE 2:1	DESIGN UNITS METRIC	THIRD ANGLE PROJECTION	REVISE ON CAD ONLY	
		▽ = 0	mm INCH	DIMENSION STYLE MM ONLY		TITLE		
		▽ = 0	4 PLACES ± --- ± ---	DRAWN BY DATE		ASSEMBLY VERTICAL SMT CF CARD 50P HEADER TYPE I		
			3 PLACES ± --- ± ---	XU XIANG 2003-11-06				
		2 PLACES ± 0.2 ± ---	CHECKED BY DATE	MATERIAL NO.		DOCUMENT NO.	SHEET NO.	
		1 PLACE ± --- ± ---	JLU 2003-11-06	7470260001		SD-47026-001	1 OF 1	
		ANGULAR ± 1/2°	APPROVED BY DATE	THIS DRAWING CONTAINS INFORMATION THAT IS PROPRIETARY TO MOLEX INCORPORATED AND SHOULD NOT BE USED WITHOUT WRITTEN PERMISSION				
		DRAFT WHERE APPLICABLE	SHUANG 2003-11-06					
		MUST REMAIN WITHIN DIMENSIONS						