

SHARP

OPTO-ANALOG DEVICES DIVISION
ELECTRONIC COMPONENTS GROUP
SHARP CORPORATION

SPECIFICATION

DEVICE SPECIFICATION FOR

Analog Output Type Distance Measuring Sensor

MODEL No.

GP2Y0A41SK0F

Enclosed please find copies of the Specifications which consists of 10 pages including cover.
After confirmation of the contents, please be sure to send back copies of the Specifications
with approving signature on each.

CUSTOMER'S APPROVAL

DATE

BY

PRESENTED

DATE

BY

H. O

H. Ogura,
Department General Manager of
Engineering Dept., III
Opto-Analog Devices Division.
ELECOM Group
SHARP CORPORATION

Product name : Analog output type distance measuring Sensor

Model No. : GP2Y0A41SK0F

1. These specification sheets include materials protected under copyright of Sharp Corporation ("Sharp"). Please do not reproduce or cause anyone to reproduce them without Sharp's consent.
2. When using this product, please observe the absolute maximum ratings and the instructions for use outlined in these specification sheets, as well as the precautions mentioned below. Sharp assumes no responsibility for any damage resulting from use of the product which does not comply with the absolute maximum ratings and the instructions included in these specification sheets, and the precautions mentioned below.

(Precautions)

- (1) This product is designed for use in the following application areas ;

• Computers • OA equipment • Telecommunication equipment (Terminal)
• Measuring equipment • Tooling machines • Audio visual equipment
• Home appliances

If the use of the product in the above application areas is for equipment listed in paragraphs (2) or (3), please be sure to observe the precautions given in those respective paragraphs.

- (2) Appropriate measures, such as fail-safe design and redundant design considering the safety design of the overall system and equipment, should be taken to ensure reliability and safety when this product is used for equipment which demands high reliability and safety in function and precision, such as ;

• Transportation control and safety equipment (aircraft, train, automobile etc.)
• Traffic signals • Gas leakage sensor breakers • Rescue and security equipment
• Other safety equipment

- (3) Please do not use this product for equipment which require extremely high reliability and safety in function and precision, such as ;

• Space equipment • Telecommunication equipment (for trunk lines)
• Nuclear power control equipment • Medical equipment

- (4) Please contact and consult with a Sharp sales representative if there are any questions regarding interpretation of the above three paragraphs.

3. Please contact and consult with a Sharp sales representative for any questions about this product.

1. Application

This specification applies to the outline and the characteristics of the analog output distance measuring sensor ;
Model No. GP2Y0A41SK0F

2. Outline

Refer to the attached drawing No. CY13036j02.

3. Ratings and characteristics

Refer to the attached sheet, page 4, 5.

4. Reliability

Refer to the attached sheet, Page 6.

5. Outgoing inspection

Refer to the attached sheet, Page 6.

6. Supplements

6-1 GP2Y0A41SK0F Example of output distance characteristics

Refer to the attached sheet, page 8.

6-2 GP2Y0A41SK0F Example of output characteristics with the inverse of distance

Refer to the attached sheet, page 9.

6-3 This product shall not contain the following materials.

Also, the following materials shall not be used in the production process for this product.

Materials for ODS : CFCs, Halon, Carbon tetrachloride 1.1.1-Trichloroethane (Methyl chloroform).

6-4 Product mass : Approx. 3.6g (TYP)

6-5 This product does not contain the chemical materials regulated by RoHS directive.

(Except for the NOT regulated by RoHS directive.)

6-6 Compliance with each regulation

6-6-1 The RoHS directive(2002/95/EC)

This product complies with the RoHS directive(2002/95/EC).

Object substances: mercury, lead (except for lead in high melting temperature type solders^{*1} and glass of electronic components), cadmium, hexavalent chromium, polybrominated biphenyls (PBB) and polybrominated diphenyl ethers (PBDE)

*1 : i.e. tin-lead solder alloys containing more than 85% lead

6-6-2 Content of six substances specified in Management Methods for Control of Pollution Caused by Electronic Information Products Regulation (Chinese : 电子信息产品污染控制管理办法).

Category	Toxic and hazardous substances					
	Lead (Pb)	Mercury (Hg)	Cadmium (Cd)	Hexavalent chromium (Cr(VI))	Polybrominated biphenyls (PBB)	Polybrominated diphenyl ethers (PBDE)
Voltage regulator	*	✓	✓	✓	✓	✓

✓ : indicates that the content of the toxic and hazardous substance in all the homogeneous materials of the part is below the concentration limit requirement as described in SJ/T 11363-2006 standard .

* : indicates that the content of the toxic and hazardous substance in at least one homogeneous material of the part exceeds the concentration limit requirement as described in SJ/T 11363-2006 standard.

Lead in high melting temperature type solders (i.e. tin-lead solder alloys containing more than 85% lead) and glass of electronic components (designated by "*" in the above table) are exempt from the RoHS directive (2002/95/EC) , because there is no effective way to eliminate or substitute them by present scientific technology.

7. Notes

Refer to the attached sheet, page 7.

2. Outline

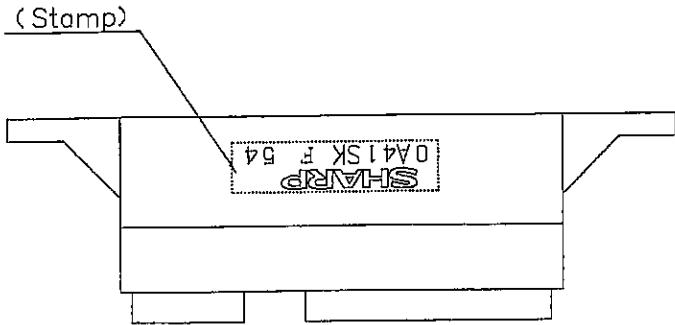

Stamp (Example)

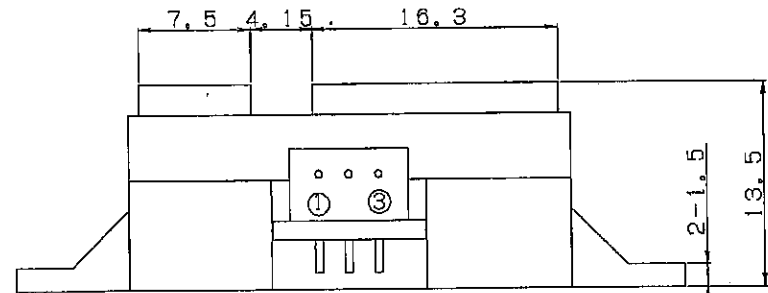
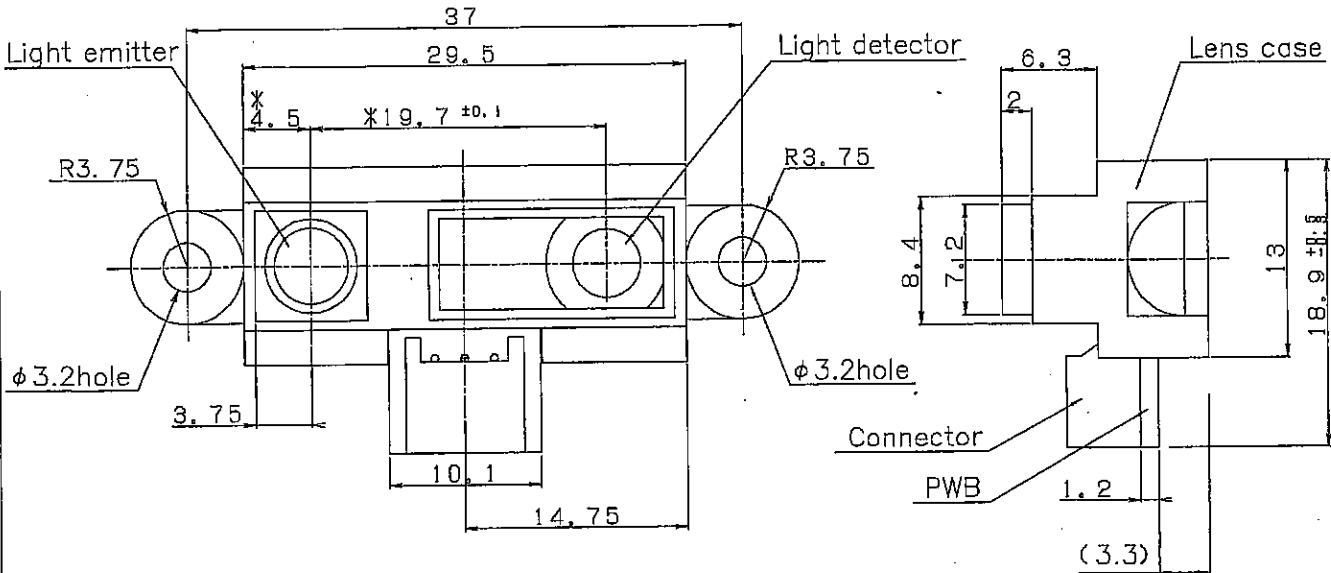
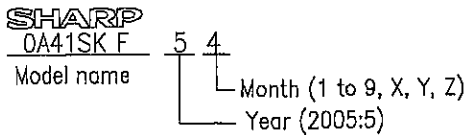

Connector signal

Signal name
① V _o
② GND
③ V _{cc}

Connector :
 J.S.T.TRADING COMPANY,LTD.
 S3B-PH

Materials

- Lens: Acrylic acid resin
 (Visible light cut-off resin)
- Case: Carbonic ABS
 (Conductive resin)
- PCB: Paper phenol

Unit: mm Scale: 2/1

Note 1: The dimensions marked * are described the dimensions of lens center position.
 Note 2: Unspecified tolerance shall be ±0.3mm.
 Note 3: The dimensions in parenthesis are shown for reference.

Name	GP2Y0A41SK0F Outline Dimensions
Drawing No.	CY13036j02

3-1 Schematic

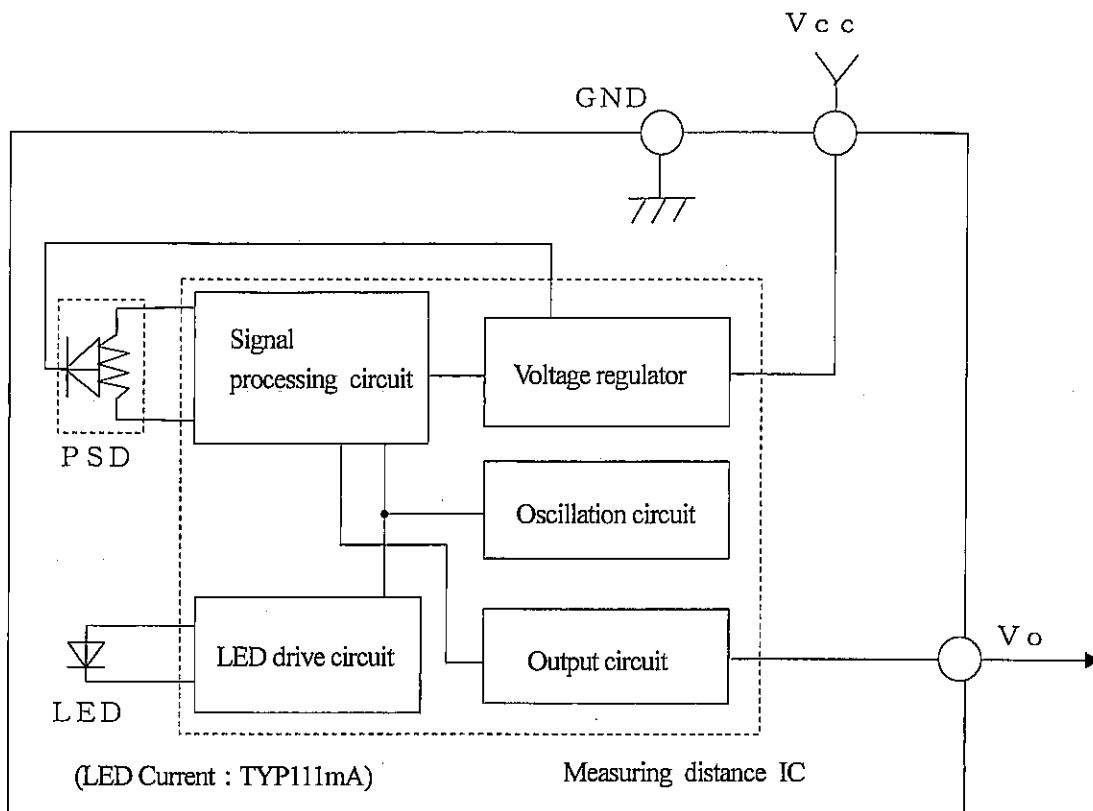

3-2 Absolute maximum ratings

(Ta=25°C, Vcc=5V)

Parameter	Symbol	Ratings	Unit	Remark
Supply voltage	Vcc	-0.3 to +7	V	-
Output terminal voltage	Vo	-0.3 to Vcc+0.3	V	-
Operating temperature	Topr	-10 to +60	°C	-
Storage temperature	Tstg	-40 to +70	°C	-

Operating supply voltage

Symbol	Rating	Unit	Remark
Vcc	4.5 to 5.5	V	-

3-3 Electro-optical Characteristics

Parameter	Symbol	Conditions	MIN.	TYP.	MAX.	Unit
Measuring distance range	ΔL	(Note 1)	4	-	30	cm
Output terminal voltage	V_o	L=30cm (Note 1)	0.25	0.4	0.55	V
Output voltage difference	ΔV_o	Output change at L change (30cm \rightarrow 4cm) (Note 1)	1.95	2.25	2.55	V
Average supply current	I_{cc}	L=30cm (Note 1)	-	12	22	mA

※ L: Distance to reflective object

(Note 1) Using reflective object : White paper (Made by Kodak Co., Ltd. gray cards R-27* white face, reflective ratio ; 90%)

3-4 Timing chart

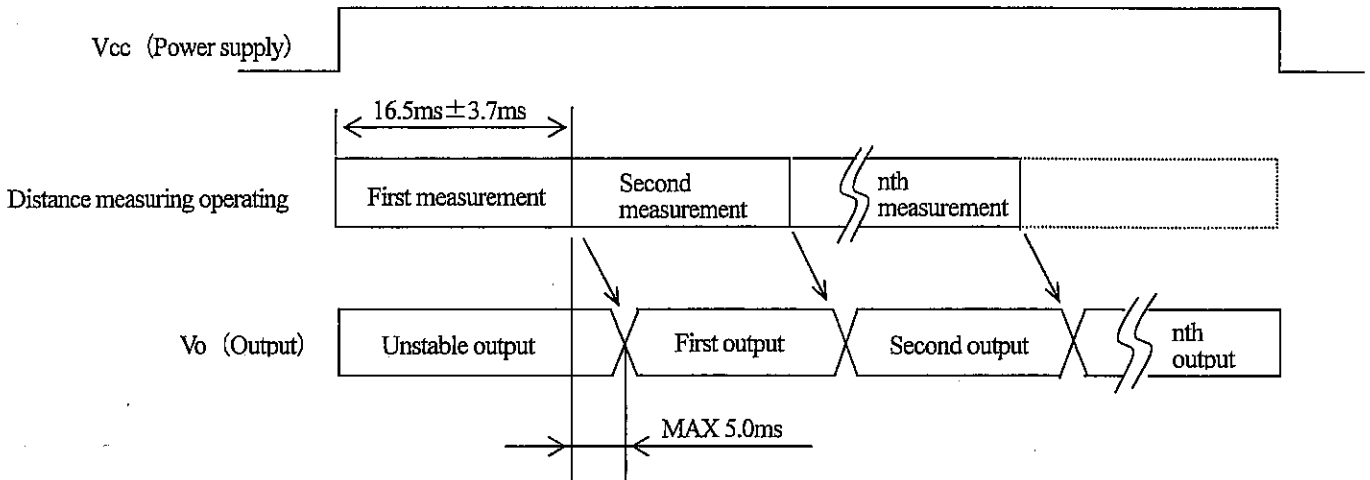

4. Reliability

The reliability of products shall be satisfied with items listed below.

Confidence level : 90%
LTPD : 20 or 30

No.	Test Items	Test Conditions	Failure Judgement Criteria	Samples (n)
				Defective (c)
1	Temperature cycling	1 cycle -40°C to +70°C (30min.) (30min.) 25 cycle test	Initial × 0.8 > Vo Vo > Initial × 1.2 (Note 1)	n=11, c=0
2	High temp. and high humidity storage	+40°C, 90%RH, 500h		n=11, c=0
3	High temp. storage	+70°C, 500h		n=11, c=0
4	Low temp. storage	-40°C, 500h		n=11, c=0
5	Operation life (High temp.)	+60°C, Vcc=5V, 500h		n=11, c=0
6	Mechanical shock	1000m/s ² , 6.0ms 3times/±X, ±Y, ±Z direction		n=8, c=0
7	Variable frequency vibration	10 to 55 to 10Hz/1min. 2h/X, Y, Z direction overall amplitude : 1.5mm		n=8, c=0

(Note 1) Test conditions are according to 3-3 Electro-optical characteristics.

(Note 2) After test, measurement shall be measured after leaving under the normal temperature and the normal humidity for two hours. But no dew point.

5. Outgoing inspection

(1) Inspection lot

Inspection shall be carried out per each delivery lot.

(2) Inspection method

A single sampling plan, normal inspection level II based on ISO 2859 is applied.

The AQL according to the inspection items are shown below.

Defect	Inspection item	AQL (%)
Major defect	Electro-optical characteristics defect (In para. 3-3)	0.4
Minor defect	Defect on appearance and dimension ※ Crack, chip, scratch, stain	1.0

※ Crack, chip, scratch, stain

One which affects the characteristics of para. 3-3 shall be defect.

7. Notes

[Advice for the optics]

7-1 Lens of this device shall be kept cleanly. There are cases that dust, water or oil and so on deteriorate the characteristics of this device. Please consider in actual application.

7-2 In case that protection is set in front of the emitter and detector portion, the protection cover which has the most efficient transmittance at the emitting wavelength range of LED for this product ($\lambda=870\text{nm}\pm 70\text{nm}$), shall be recommended to use. The face and back of protection cover should be mirror polishing. Also, as there are cases that the characteristics may not be satisfied with according to the distance between the protection cover and this product or the thickness of the protection cover, please use this product after confirming the operation sufficiently in actual application.

[Advice for the characteristics]

7-3 In case that there is an object near to light exits of the sensor between the sensor and the detected object, please use this device after confirming sufficiently what the characteristics of this sensor do not change by the object.

7-4 When the detector surface receive direct light from the sun, tungsten lamp and so on, there are cases that it can not measure the distance exactly. Please consider the design that the detector does not receive direct light from such light source.

7.5 Distance between sensor and mirror reflector can not sometimes measure exactly.
In case of changing the mounting angle of this product, it may measure the distance exactly.

7.6 In case that reflective object has boundary line clearly, there is cases that distance can not measure exactly. At that time, if direction of boundary line and the line between emitter center and detector center parallels, it is possible to decrease deviation of measuring distance.

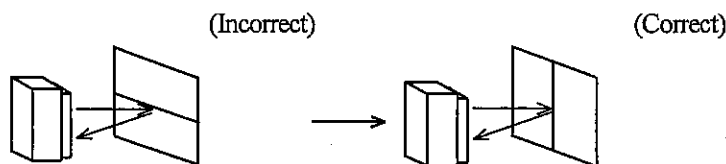

7-7 In order to decrease measuring error by moving direction of object, we recommend to mount the sensor like below drawing.

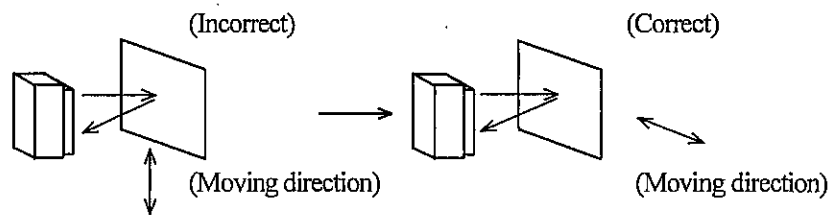

7-8 In order to stabilize power supply line, we recommend to connect a by-pass capacitor of 10 μ F or more between Vcc and GND near this product.

[Notes on handling]

7-9 Please don't do washing. Washing may deteriorate the characteristics of optical system and so on.

Please confirm resistance to chemicals under the actual usage since this product has not been designed against for washing.

7-10 There are some possibilities that the sensor inside the case package with lens may be exposed to the excessive mechanical stress. Please be careful not to cause any excessive pressure on the case package with lens and also on the PCB at the assembly and inserting of the set.

6-1 GP2Y0A41SK0F Example of output distance characteristics

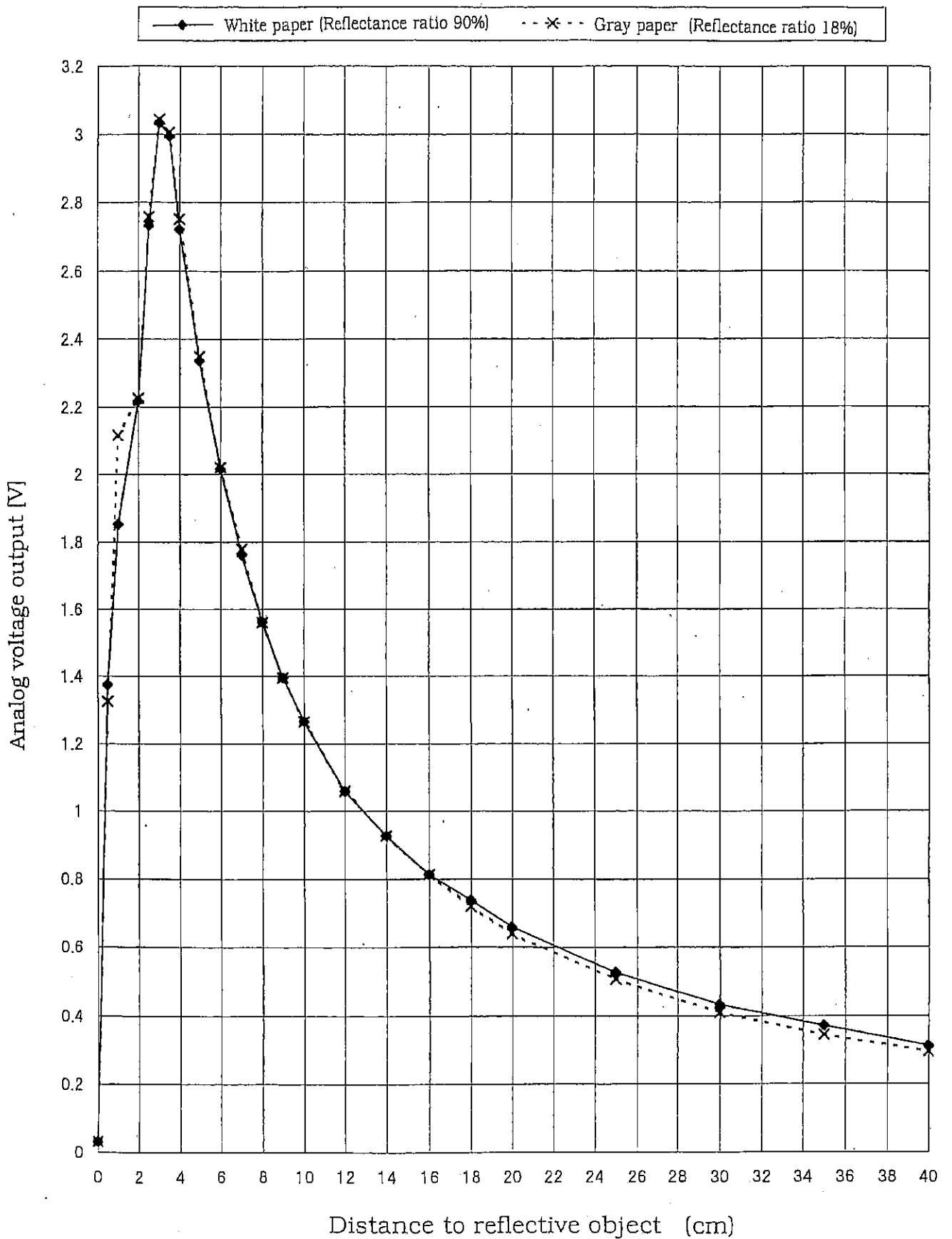

6-2 GP2Y0A41SK0F Example of output distance characteristics with the inverse of distance

