

Switched-Capacitor Voltage Converter with Regulator

FEATURES

- Available in Space Saving SO-8 Package
- Output Current: 100mA (LT1054)
125mA (LT1054L)
- Low Loss: 1.1V at 100mA
- Operating Range: 3.5V to 15V (LT1054)
3.5V to 7V (LT1054L)
- Reference and Error Amplifier for Regulation
- External Shutdown
- External Oscillator Synchronization
- Can Be Paralleled
- Pin Compatible with the LTC[®]1044/LTC7660

APPLICATIONS

- Voltage Inverter
- Voltage Regulator
- Negative Voltage Doubler
- Positive Voltage Doubler

DESCRIPTION

The LT[®]1054 is a monolithic, bipolar, switched-capacitor voltage converter and regulator. The LT1054 provides higher output current than previously available converters with significantly lower voltage losses. An adaptive switch driver scheme optimizes efficiency over a wide range of output currents. Total voltage loss at 100mA output current is typically 1.1V. This holds true over the full supply voltage range of 3.5V to 15V. Quiescent current is typically 2.5mA.

The LT1054 also provides regulation, a feature not previously available in switched-capacitor voltage converters. By adding an external resistive divider a regulated output can be obtained. This output will be regulated against changes in both input voltage and output current. The LT1054 can also be shut down by grounding the feedback pin. Supply current in shutdown is less than 100 μ A.

The internal oscillator of the LT1054 runs at a nominal frequency of 25kHz. The oscillator pin can be used to adjust the switching frequency or to externally synchronize the LT1054.

The LT1054 is pin compatible with previous converters such the LTC1044/LTC7660.

LT, LTC and LT are registered trademarks of Linear Technology Corporation.

BLOCK DIAGRAM

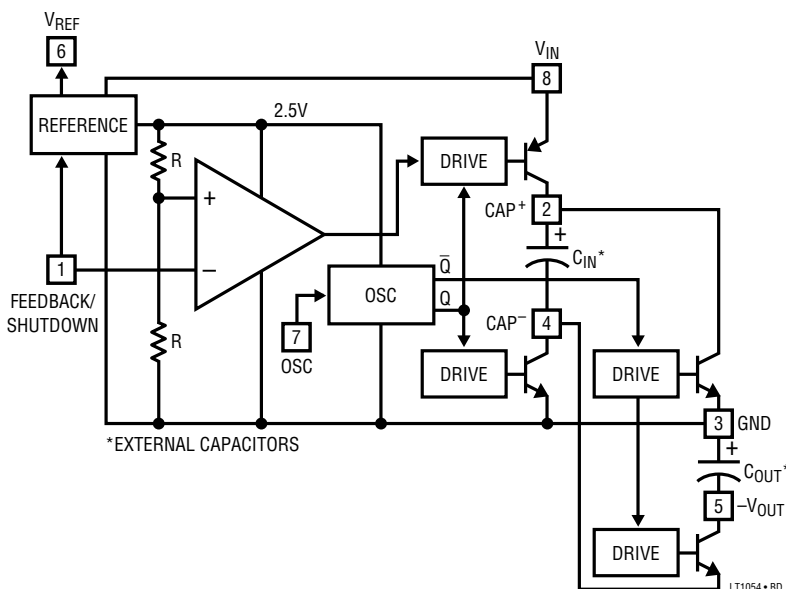

LT1054/LT1054L Voltage Loss

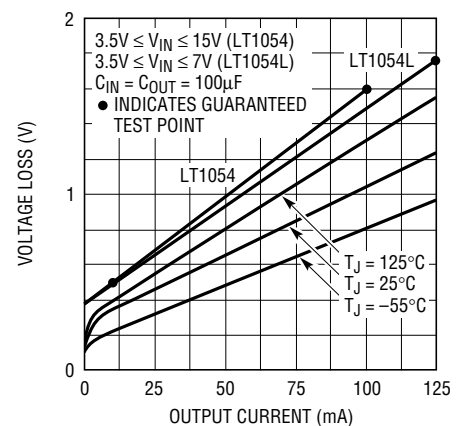

1054 TA01*

LT1054/LT1054L

ABSOLUTE MAXIMUM RATINGS (Note 1)

Supply Voltage (Note 2)

LT1054	16V
LT1054L	7V

Input Voltage

Pin 1	$0V \leq V_{PIN1} \leq V^+$
Pin 3 (S Package)	$0V \leq V_{PIN3} \leq V^+$
Pin 7	$0V \leq V_{PIN7} \leq V_{REF}$
Pin 13 (S Package)	$0V \leq V_{PIN13} \leq V_{REF}$

Operating Junction Temperature Range

LT1054C/LT1054LC	0°C to 100°C
LT1054I	-40°C to 100°C
LT1054M	-55°C to 125°C

Maximum Junction Temperature (Note 3)

LT1054C/LT1054LC	125°C
LT1054I	125°C
LT1054M	150°C

Storage Temperature Range

H, J8, N8 and S8 Packages	-55°C to 150°C
S Package	-65°C to 150°C

Lead Temperature (Soldering, 10 sec)

	300°C
--	-------

PACKAGE/ORDER INFORMATION (Note 6)

<p>TOP VIEW</p> <p>8-LEAD TO-5 METAL CAN</p> <p>$T_{JMAX} = 150^{\circ}\text{C}$, $\theta_{JA} = 150^{\circ}\text{C/W}$, $\theta_{JC} = 45^{\circ}\text{C/W}$</p>	<p>ORDER PART NUMBER</p> <p>LT1054CH LT1054MH</p>	<p>TOP VIEW</p> <p>S8 PACKAGE 8-LEAD PLASTIC SO</p> <p>$T_{JMAX} = 125^{\circ}\text{C}$, $\theta_{JA} = 120^{\circ}\text{C/W}$</p> <p>SEE REGULATION AND CAPACITOR SELECTION SECTIONS IN THE APPLICATIONS INFORMATION FOR IMPORTANT INFORMATION ON THE S8 DEVICE</p>	<p>ORDER PART NUMBER</p> <p>LT1054CS8 LT1054LCS8</p> <p>S8 PART MARKING</p> <p>1054 1054L</p>
<p>TOP VIEW</p> <p>J8 PACKAGE 8-LEAD CERAMIC DIP</p> <p>$T_{JMAX} = 150^{\circ}\text{C}$, $\theta_{JA} = 100^{\circ}\text{C/W}$ (J8) $T_{JMAX} = 125^{\circ}\text{C}$, $\theta_{JA} = 130^{\circ}\text{C/W}$ (N8)</p>	<p>ORDER PART NUMBER</p> <p>LT1054CJ8 LT1054CN8 LT1054IN8 LT1054MJ8</p>	<p>TOP VIEW</p> <p>SW PACKAGE 16-LEAD PLASTIC SO</p> <p>$T_{JMAX} = 125^{\circ}\text{C}$, $\theta_{JA} = 150^{\circ}\text{C/W}$</p>	<p>ORDER PART NUMBER</p> <p>LT1054CSW LT1054ISW</p>

TYPICAL PERFORMANCE CHARACTERISTICS

Shutdown Threshold

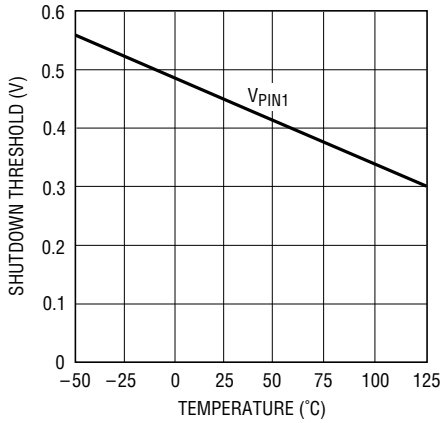

LT1054 • TPC01

Supply Current

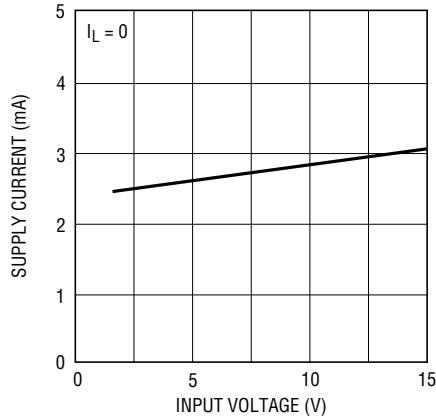

LT1054 • TPC02

Oscillator Frequency

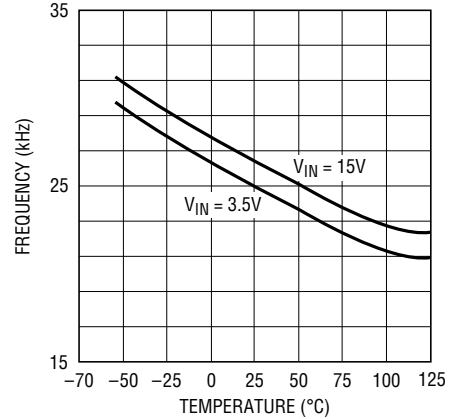

LT1054 • TPC03

Supply Current in Shutdown

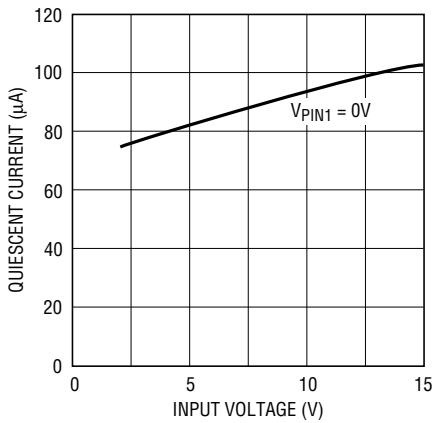

LT1054 • TPC04

Average Input Current

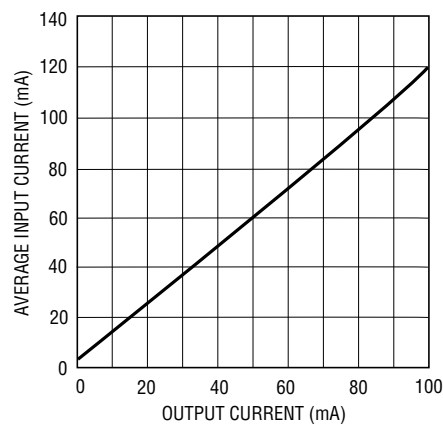

LT1050 • TPC05

Output Voltage Loss

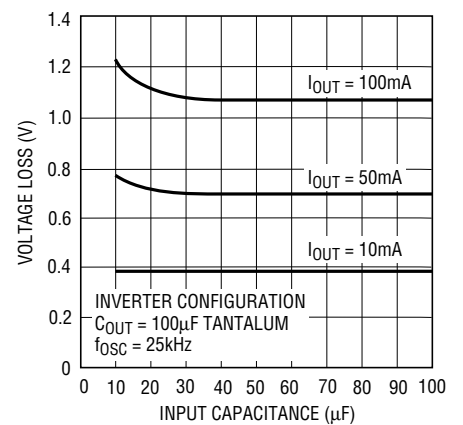

LT1054 • TPC06

Output Voltage Loss

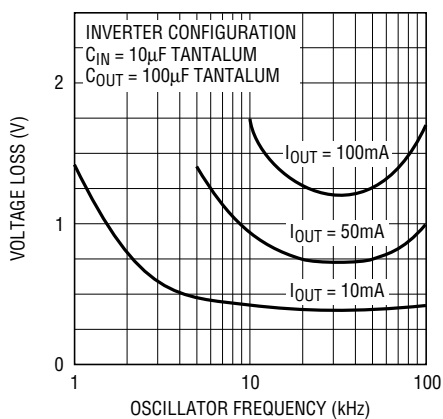

LT1054 • TPC07

Output Voltage Loss

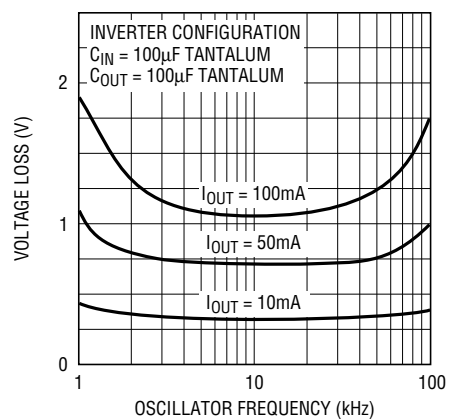

LT1054 • TPC08

TYPICAL PERFORMANCE CHARACTERISTICS

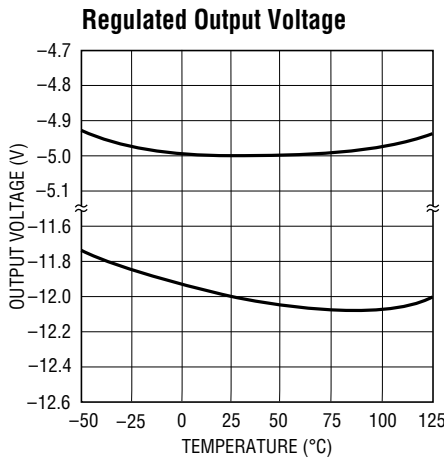

LT1054 • TPC09

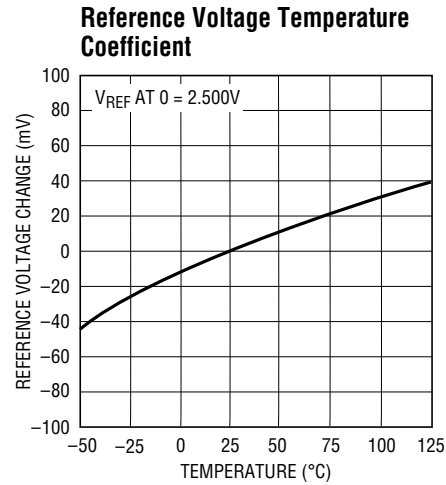

LT1054 • TPC10

PIN FUNCTIONS

FB/SHDN (Pin 1): Feedback/Shutdown Pin. This pin has two functions. Pulling Pin 1 below the shutdown threshold ($\approx 0.45V$) puts the device into shutdown. In shutdown the reference/regulator is turned off and switching stops. The switches are set such that both C_{IN} and C_{OUT} are discharged through the output load. Quiescent current in shutdown drops to approximately $100\mu A$ (see Typical Performance Characteristics). Any open-collector gate can be used to put the LT1054 into shutdown. For normal (unregulated) operation the device will start back up when the external gate is shut off. In LT1054 circuits that use the regulation feature, the external resistor divider can provide enough pull-down to keep the device in shutdown until the output capacitor (C_{OUT}) has fully discharged. For most applications where the LT1054 would be run intermittently, this does not present a problem because the discharge time of the output capacitor will be short compared to the off-time of the device. In applications where the device has to start up before the output capacitor (C_{OUT}) has fully discharged, a restart pulse must be applied to Pin 1 of the LT1054. Using the circuit of Figure 5, the restart signal can be either a pulse ($t_p > 100\mu s$) or a logic high. Diode coupling the restart signal into Pin 1 will allow the output voltage to come up and regulate without overshoot. The resistor divider $R3/R4$ in Figure 5 should be chosen to provide a signal level at pin 1 of $0.7V$ to $1.1V$.

Pin 1 is also the inverting input of the LT1054's error amplifier and as such can be used to obtain a regulated output voltage.

CAP+/CAP- (Pin 2/Pin 4): Pin 2, the positive side of the input capacitor (C_{IN}), is alternately driven between V^+ and ground. When driven to V^+ , Pin 2 sources current from V^+ . When driven to ground Pin 2 sinks current to ground. Pin 4, the negative side of the input capacitor, is driven alternately between ground and V_{OUT} . When driven to ground, Pin 4 sinks current to ground. When driven to V_{OUT} Pin 4 sources current from C_{OUT} . In all cases current flow in the switches is unidirectional as should be expected using bipolar switches.

V_{OUT} (Pin 5): In addition to being the output pin this pin is also tied to the substrate of the device. **Special care must be taken in LT1054 circuits to avoid pulling this pin positive with respect to any of the other pins.** Pulling Pin 5 positive with respect to Pin 3 (GND) will forward bias the substrate diode which will prevent the device from starting. This condition can occur when the output load driven by the LT1054 is referred to its positive supply (or to some other positive voltage). Note that most op amps present just such a load since their supply currents flow from their V^+ terminals to their V^- terminals. To prevent start-up problems with this type of load an external transistor must be added as shown in Figure 1. This will prevent V_{OUT} (Pin 5)

PIN FUNCTIONS

from being pulled above the ground pin (Pin 3) during start-up. Any small, general purpose transistor such as 2N2222 or 2N2219 can be used. R_X should be chosen to provide enough base drive to the external transistor so that it is saturated under nominal output voltage and maximum output current conditions. In some cases an N-channel enhancement mode MOSFET can be used in place of the transistor.

$$R_X \leq \frac{(I_{V_{OUT}})\beta}{I_{OUT}}$$

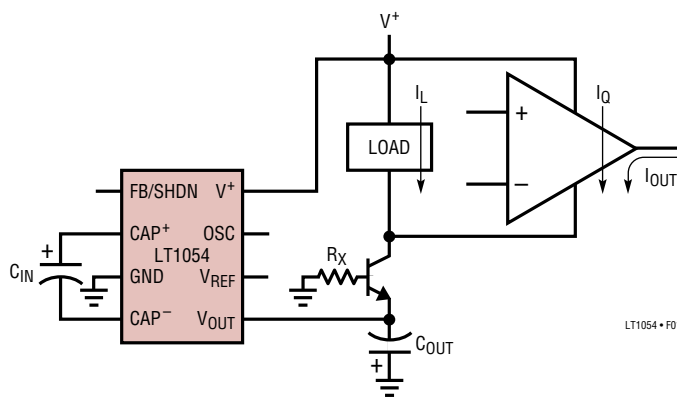

Figure 1

V_{REF} (Pin 6): Reference Output. This pin provides a 2.5V reference point for use in LT1054-based regulator circuits. The temperature coefficient of the reference voltage has been adjusted so that the temperature coefficient of the regulated output voltage is close to zero. This requires the reference output to have a positive temperature coefficient as can be seen in the typical performance curves. This nonzero drift is necessary to offset a drift term inherent in the internal reference divider and comparator network tied to the feedback pin. The overall result of these drift terms is a regulated output which has a slight positive temperature coefficient at output voltages below 5V and a slight negative TC at output voltages above 5V. Reference output current should be limited, for regulator feedback networks, to approximately 60 μ A. The reference pin will draw \approx 100 μ A when shorted to ground and will not affect the internal reference/regulator, so that this pin can also be used as a pull-up for LT1054 circuits that require synchronization.

OSC (Pin 7): Oscillator Pin. This pin can be used to raise or lower the oscillator frequency or to synchronize the device to an external clock. Internally Pin 7 is connected to the oscillator timing capacitor ($C_T \approx 150$ pF) which is alternately charged and discharged by current sources of $\pm 7\mu$ A so that the duty cycle is $\approx 50\%$. The LT1054 oscillator is designed to run in the frequency band where switching losses are minimized. However the frequency can be raised, lowered, or synchronized to an external system clock if necessary.

The frequency can be lowered by adding an external capacitor (C_1 , Figure 2) from Pin 7 to ground. This will increase the charge and discharge times which lowers the oscillator frequency. The frequency can be increased by adding an external capacitor (C_2 , Figure 2, in the range of 5pF to 20pF) from Pin 2 to Pin 7. This capacitor will couple charge into C_T at the switch transitions, which will shorten the charge and discharge time, raising the oscillator frequency. Synchronization can be accomplished by adding an external resistive pull-up from Pin 7 to the reference pin (Pin 6). A 20k pull-up is recommended. An open collector gate or an NPN transistor can then be used to drive the oscillator pin at the external clock frequency as shown in Figure 2. Pulling up Pin 7 to an external voltage is **not recommended**. For circuits that require both frequency synchronization and regulation, an external reference can be used as the reference point for the top of the R1/R2 divider allowing Pin 6 to be used as a pull-up point for Pin 7.

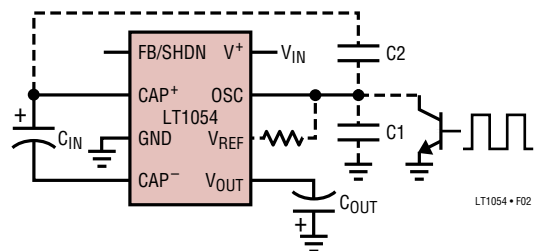

Figure 2

V⁺ (Pin 8): Input Supply. The LT1054 alternately charges C_{IN} to the input voltage when C_{IN} is switched in parallel with the input supply and then transfers charge to C_{OUT} when C_{IN} is switched in parallel with C_{OUT} . Switching occurs at

PIN FUNCTIONS

the oscillator frequency. During the time that C_{IN} is charging, the peak supply current will be approximately equal to 2.2 times the output current. During the time that C_{IN} is delivering charge to C_{OUT} the supply current drops to approximately 0.2 times the output current. An input supply bypass capacitor will supply part of the peak input current drawn by the LT1054 and average out the current

drawn from the supply. A minimum input supply bypass capacitor of $2\mu\text{F}$, preferably tantalum or some other low ESR type is recommended. A larger capacitor may be desirable in some cases, for example, when the actual input supply is connected to the LT1054 through long leads, or when the pulse current drawn by the LT1054 might affect other circuitry through supply coupling.

APPLICATIONS INFORMATION

Theory of Operation

To understand the theory of operation of the LT1054, a review of a basic switched-capacitor building block is helpful.

In Figure 3 when the switch is in the left position, capacitor C_1 will charge to voltage V_1 . The total charge on C_1 will be $q_1 = C_1V_1$. The switch then moves to the right, discharging C_1 to voltage V_2 . After this discharge time the charge on C_1 is $q_2 = C_1V_2$. Note that charge has been transferred from the source V_1 to the output V_2 . The amount of charge transferred is:

$$\Delta q = q_1 - q_2 = C_1(V_1 - V_2)$$

If the switch is cycled f times per second, the charge transfer per unit time (i.e., current) is:

$$I = (f)(\Delta q) = (f)[C_1(V_1 - V_2)]$$

To obtain an equivalent resistance for the switched-capacitor network we can rewrite this equation in terms of voltage and impedance equivalence:

$$I = \frac{V_1 - V_2}{(1/fC_1)} = \frac{V_1 - V_2}{R_{EQUIV}}$$

A new variable R_{EQUIV} is defined such that $R_{EQUIV} = 1/fC_1$. Thus the equivalent circuit for the switched-capacitor network is as shown in Figure 4. The LT1054 has the same switching action as the basic switched-capacitor building block. Even though this simplification doesn't include finite switch on-resistance and output voltage ripple, it provides an intuitive feel for how the device works.

These simplified circuits explain voltage loss as a function of frequency (see Typical Performance Characteristics). As frequency is decreased, the output impedance will eventu-

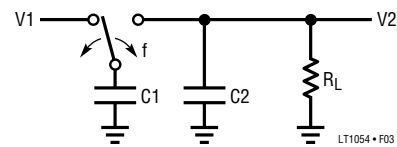

Figure 3. Switched-Capacitor Building Block

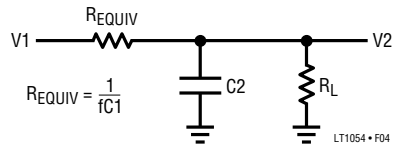

Figure 4. Switched-Capacitor Equivalent Circuit

ally be dominated by the $1/fC_1$ term and voltage losses will rise.

Note that losses also rise as frequency increases. This is caused by internal switching losses which occur due to some finite charge being lost on each switching cycle. This charge loss per-unit-cycle, when multiplied by the switching frequency, becomes a current loss. At high frequency this loss becomes significant and voltage losses again rise.

The oscillator of the LT1054 is designed to run in the frequency band where voltage losses are at a minimum.

Regulation

The error amplifier of the LT1054 servos the drive to the PNP switch to control the voltage across the input capacitor (C_{IN}) which in turn will determine the output voltage. Using the reference and error amplifier of the LT1054, an external resistive divider is all that is needed to set the regulated output voltage. Figure 5 shows the basic regulator configuration and the formula for calculating the appropriate resistor values. R_1 should be chosen to be

APPLICATIONS INFORMATION

where dV = peak-to-peak ripple and f = oscillator frequency.

For output capacitors with significant ESR a second term must be added to account for the voltage step at the switch transitions. This step is approximately equal to:

$$(2I_{OUT})(ESR \text{ of } C_{OUT})$$

Power Dissipation

The power dissipation of any LT1054 circuit must be limited such that the junction temperature of the device does not exceed the maximum junction temperature ratings. The total power dissipation must be calculated from two components, the power loss due to voltage drops in the switches and the power loss due to drive current losses. The total power dissipated by the LT1054 can be calculated from:

$$P \approx (V_{IN} - |V_{OUT}|)(I_{OUT}) + (V_{IN})(I_{OUT})(0.2)$$

where both V_{IN} and V_{OUT} are referred to the ground pin (Pin 3) of the LT1054. For LT1054 regulator circuits, the power dissipation will be equivalent to that of a linear regulator. Due to the limited power handling capability of the LT1054 packages, the user will have to limit output current requirements or take steps to dissipate some power external to the LT1054 for large input/output differentials. This can be accomplished by placing a resistor in series with C_{IN} as shown in Figure 6. A portion of the input voltage will then be dropped across this resistor without affecting the output regulation. Because switch current is approximately 2.2 times the output current and the resistor will cause a voltage drop when C_{IN} is both charging and discharging, the resistor should be chosen as:

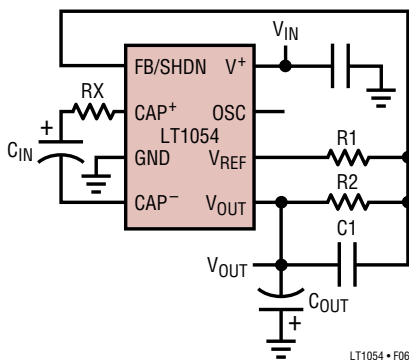

Figure 6

$$R_X = V_X / (4.4 I_{OUT})$$

where

$$V_X \approx V_{IN} - [(LT1054 \text{ Voltage Loss})(1.3) + |V_{OUT}|]$$

and I_{OUT} = maximum required output current. The factor of 1.3 will allow some operating margin for the LT1054.

For example: assume a 12V to $-5V$ converter at 100mA output current. First calculate the power dissipation without an external resistor:

$$P = (12V - |-5V|)(100mA) + (12V)(100mA)(0.2)$$

$$P = 700mW + 240mW = 940mW$$

At θ_{JA} of $130^{\circ}C/W$ for a commercial plastic device this would cause a junction temperature rise of $122^{\circ}C$ so that the device would exceed the maximum junction temperature at an ambient temperature of $25^{\circ}C$. Now calculate the power dissipation with an external resistor (R_X). First find how much voltage can be dropped across R_X . The maximum voltage loss of the LT1054 in the standard regulator configuration at 100mA output current is 1.6V, so

$$V_X = 12V - [(1.6V)(1.3) + |-5V|] = 4.9V \text{ and}$$

$$R_X = 4.9V / (4.4)(100mA) = 11\Omega$$

This resistor will reduce the power dissipated by the LT1054 by $(4.9V)(100mA) = 490mW$. The total power dissipated by the LT1054 would then be $(940mW - 490mW) = 450mW$. The junction temperature rise would now be only $58^{\circ}C$. Although commercial devices are guaranteed to be functional up to a junction temperature of $125^{\circ}C$, the specifications are only guaranteed up to a junction temperature of $100^{\circ}C$, so ideally you should limit the junction temperature to $100^{\circ}C$. For the above example this would mean limiting the ambient temperature to $42^{\circ}C$. Other steps can be taken to allow higher ambient temperatures. The thermal resistance numbers for the LT1054 packages represent worst case numbers with no heat sinking and still air. Small clip-on type heat sinks can be used to lower the thermal resistance of the LT1054 package. In some systems there may be some available airflow which will help to lower the thermal resistance. Wide PC board traces from the LT1054 leads can also help to remove heat from the device. This is especially true for plastic packages.

TYPICAL APPLICATIONS

Basic Voltage Inverter

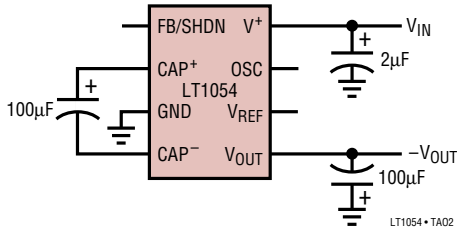

LT1054 • TA02

Basic Voltage Inverter/Regulator

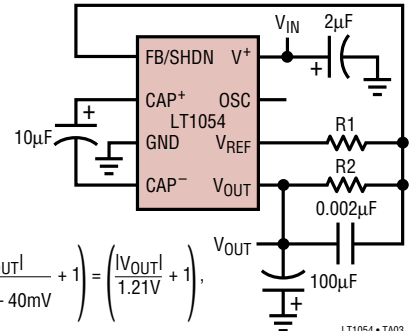

$$\frac{R2}{R1} = \left(\frac{|V_{OUT}|}{\frac{V_{REF}}{2} - 40mV} + 1 \right) = \left(\frac{|V_{OUT}|}{1.21V} + 1 \right)$$

REFER TO FIGURE 5

LT1054 • TA03

Negative Voltage Doubler

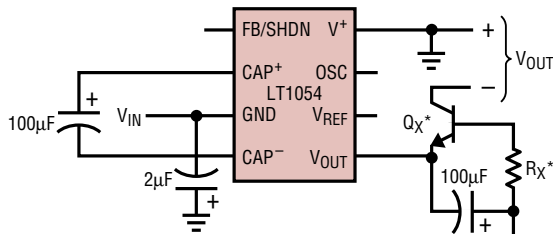

$V_{IN} = -3.5V \text{ TO } -15V$
 $V_{OUT} = 2V_{IN} + (\text{LT1054 VOLTAGE LOSS}) + (Q_X \text{ SATURATION VOLTAGE})$
 *SEE FIGURE 3

LT1054 • TA04

Positive Doubler

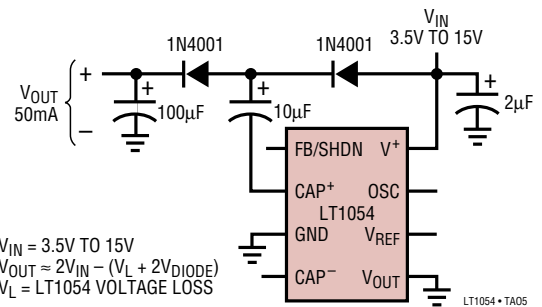

$V_{IN} = 3.5V \text{ TO } 15V$
 $V_{OUT} \approx 2V_{IN} - (V_L + 2V_{D10DE})$
 $V_L = \text{LT1054 VOLTAGE LOSS}$

LT1054 • TA05

100mA Regulating Negative Doubler

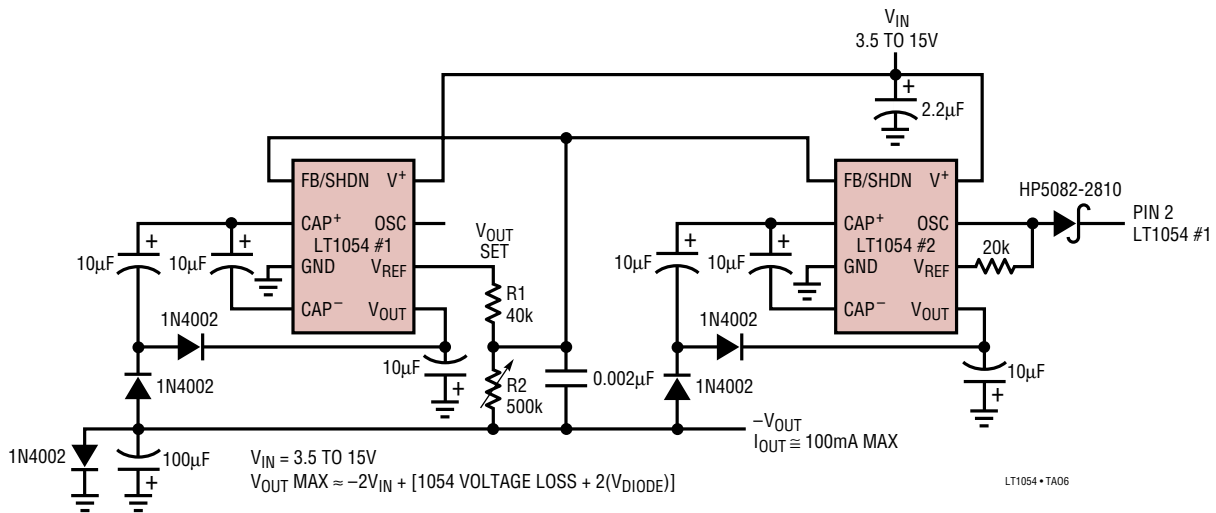

$V_{IN} = 3.5 \text{ TO } 15V$
 $V_{OUT \text{ MAX}} \approx -2V_{IN} + [1054 \text{ VOLTAGE LOSS} + 2(V_{D10DE})]$

$$\frac{R2}{R1} = \left(\frac{|V_{OUT}|}{\frac{V_{REF}}{2} - 40mV} + 1 \right) = \left(\frac{|V_{OUT}|}{1.21V} + 1 \right), \text{ REFER TO FIGURE 5}$$

LT1054 • TA06

TYPICAL APPLICATIONS

Bipolar Supply Doubler

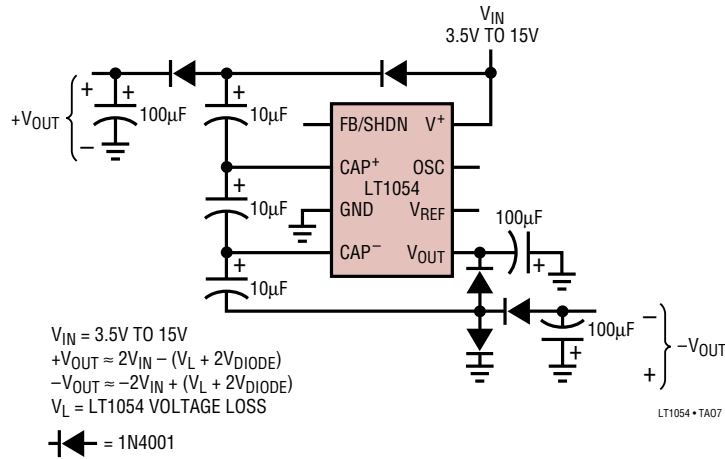

5V to ±12V Converter

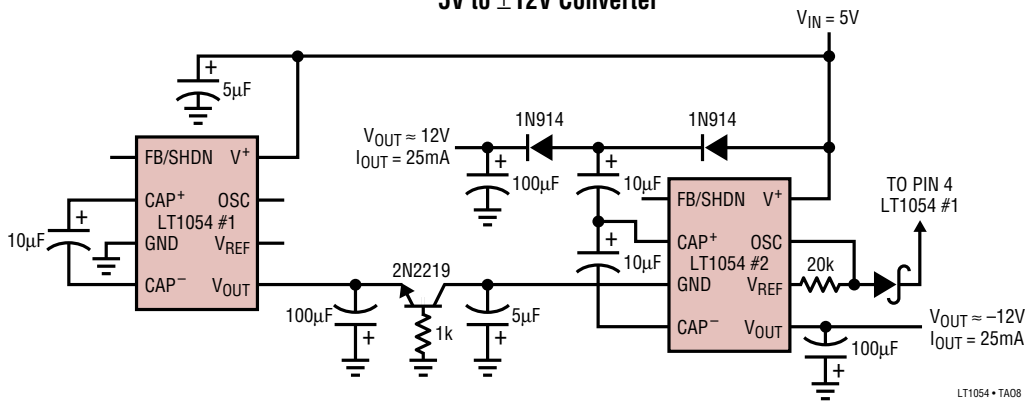

Strain Gauge Bridge Signal Conditioner

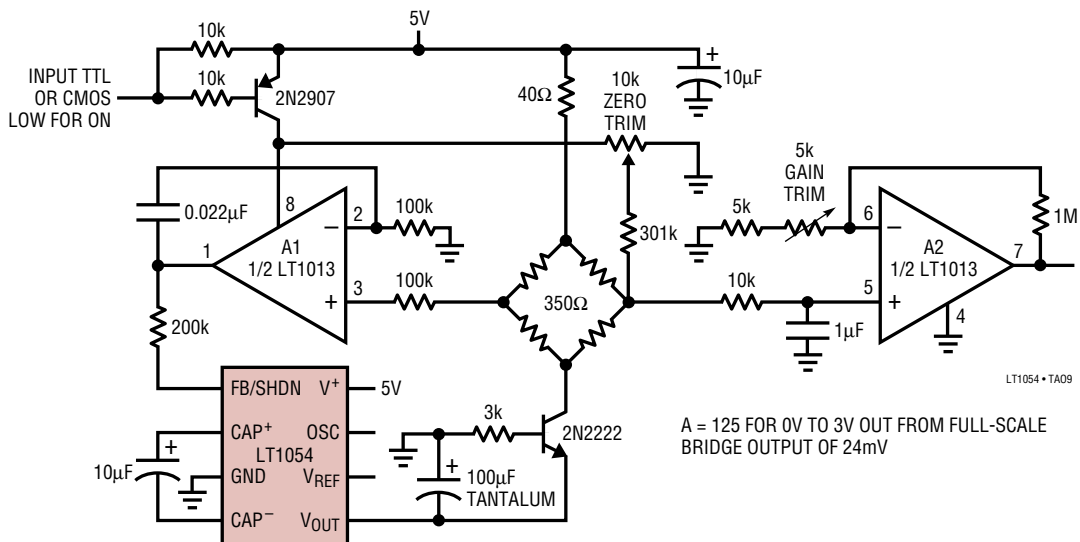

TYPICAL APPLICATIONS

3.5V to 5V Regulator

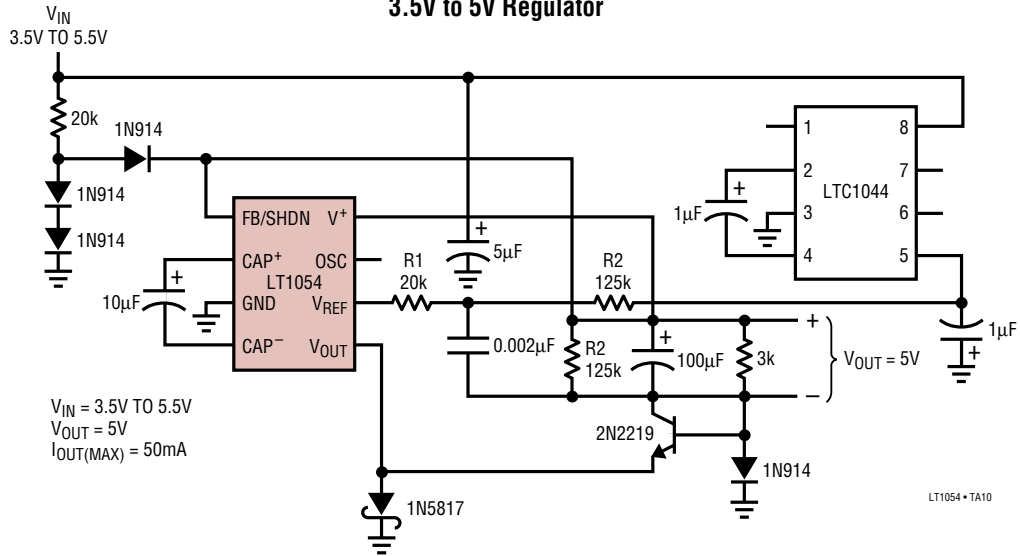

Regulating 200mA, 12V to -5V Converter

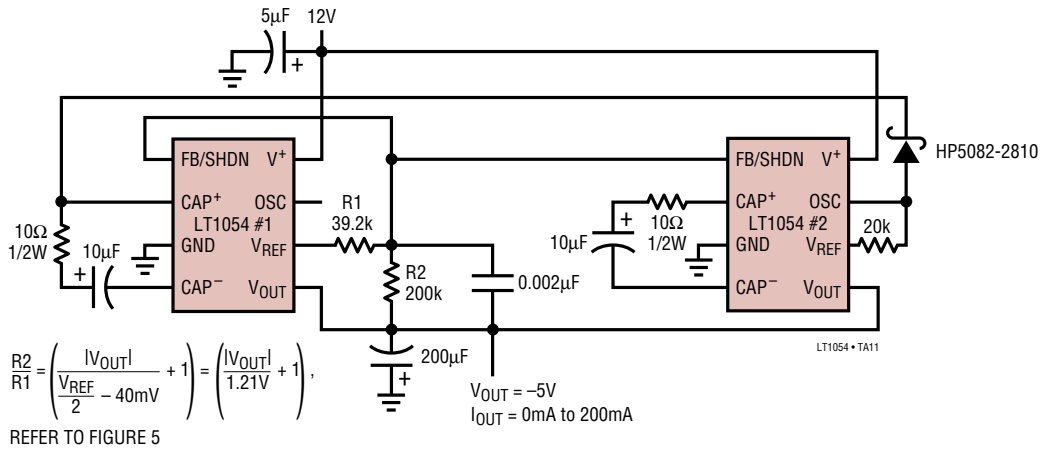

Digitally Programmable Negative Supply

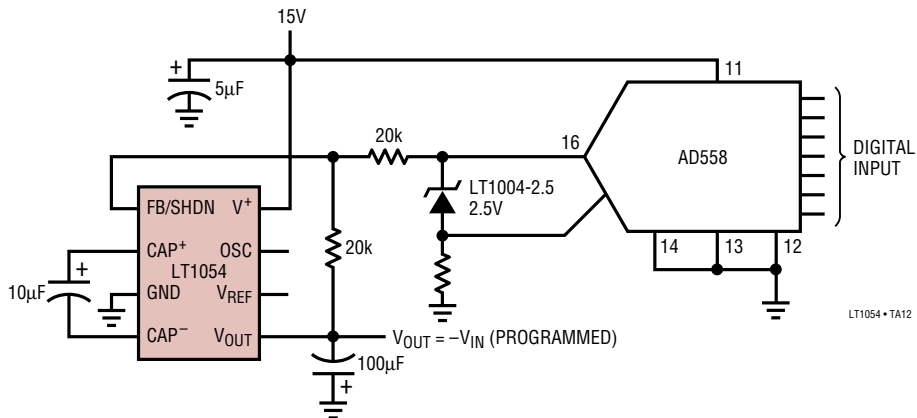

PACKAGE DESCRIPTION Dimensions in inches (millimeters) unless otherwise noted.

H Package
8-Lead TO-5 Metal Can (0.200 PCD)
 (LTC DWG # 05-08-1320)

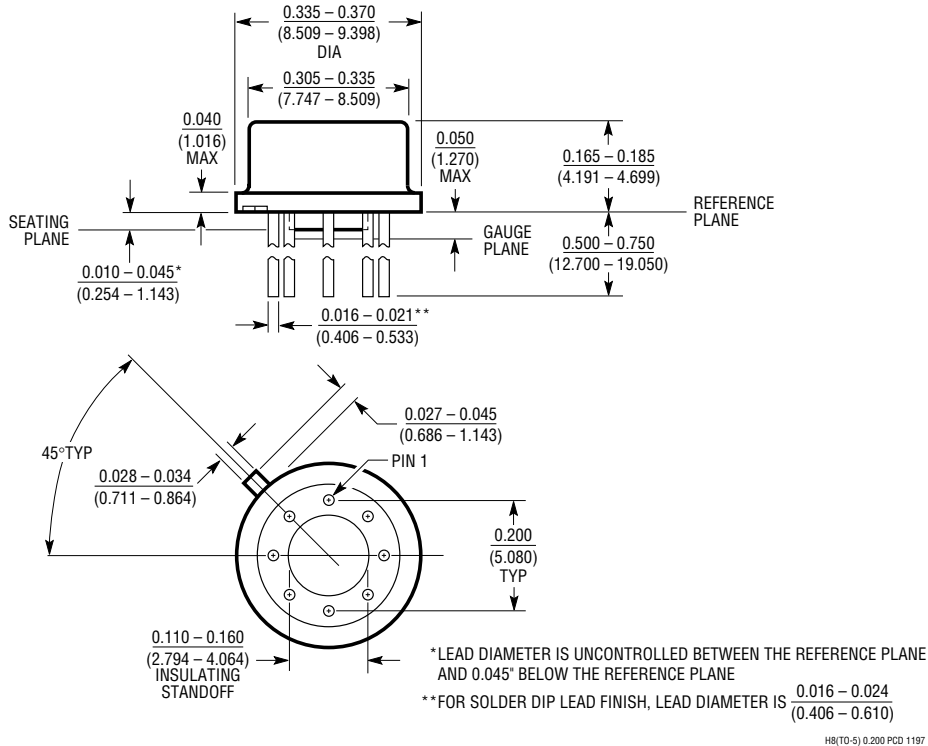

J8 Package
8-Lead Cerdip (Narrow 0.300, Hermetic)
 (LTC DWG # 05-08-1110)

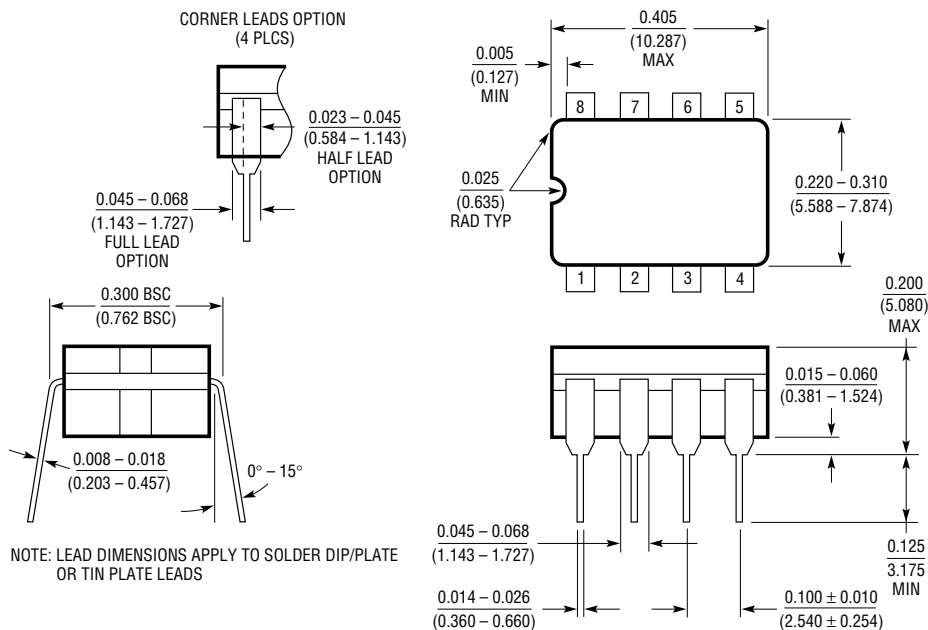

PACKAGE DESCRIPTION Dimensions in inches (millimeters) unless otherwise noted.

N8 Package
8-Lead PDIP (Narrow 0.300)
 (LTC DWG # 05-08-1510)

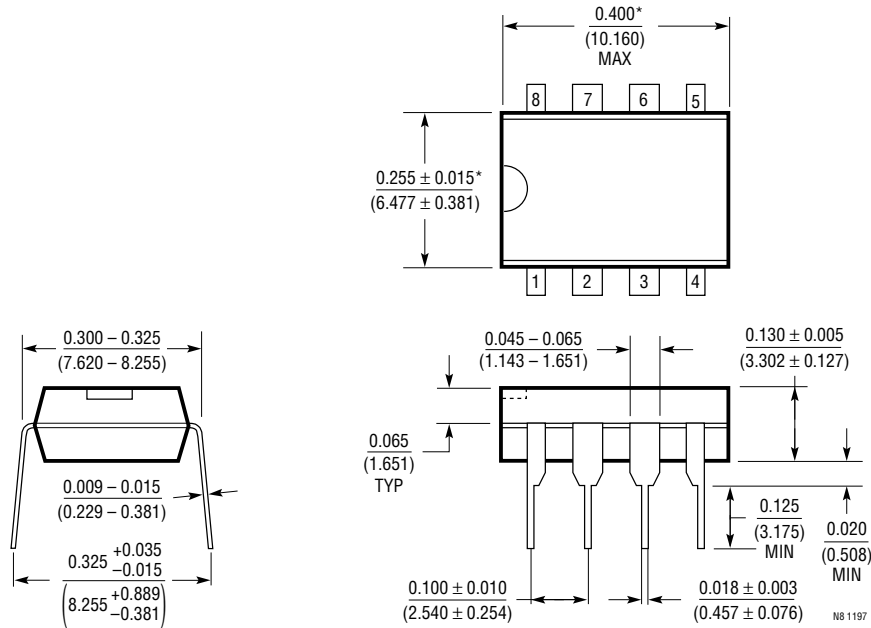

*THESE DIMENSIONS DO NOT INCLUDE MOLD FLASH OR PROTRUSIONS.
 MOLD FLASH OR PROTRUSIONS SHALL NOT EXCEED 0.010 INCH (0.254mm)

S8 Package
8-Lead Plastic Small Outline (Narrow 0.150)
 (LTC DWG # 05-08-1610)

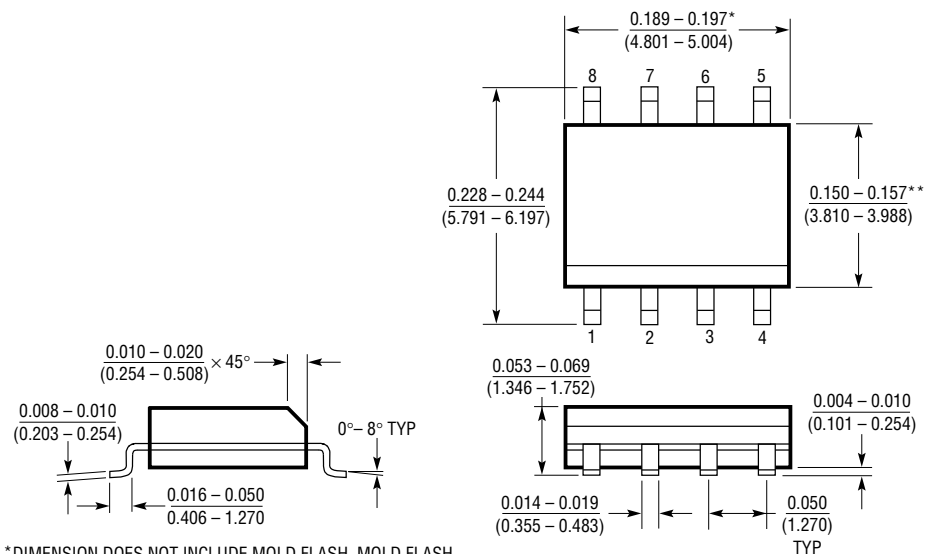

*DIMENSION DOES NOT INCLUDE MOLD FLASH. MOLD FLASH SHALL NOT EXCEED 0.006" (0.152mm) PER SIDE

**DIMENSION DOES NOT INCLUDE INTERLEAD FLASH. INTERLEAD FLASH SHALL NOT EXCEED 0.010" (0.254mm) PER SIDE

PACKAGE DESCRIPTION Dimensions in inches (millimeters) unless otherwise noted.

SW Package
16-Lead Plastic Small Outline (Wide 0.300)
 (LTC DWG # 05-08-1620)

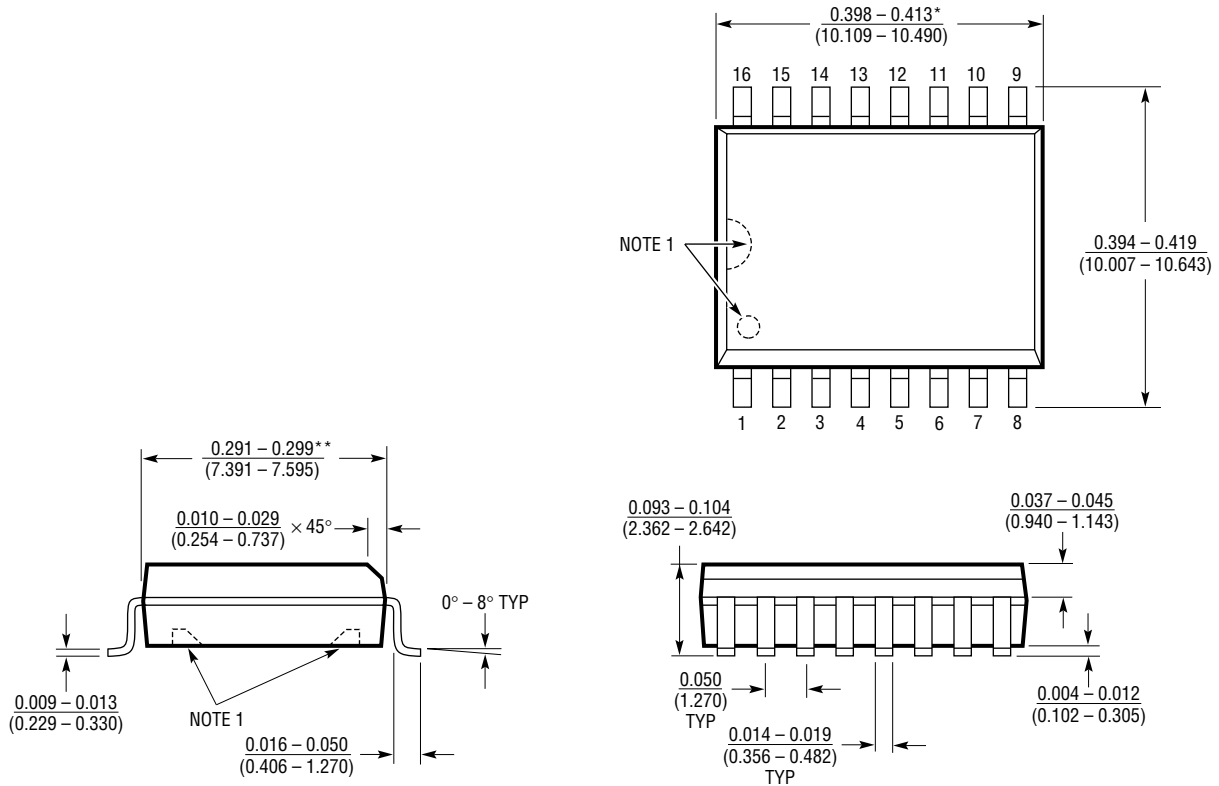

NOTE:
 1. PIN 1 IDENT, NOTCH ON TOP AND CAVITIES ON THE BOTTOM OF PACKAGES ARE THE MANUFACTURING OPTIONS.
 THE PART MAY BE SUPPLIED WITH OR WITHOUT ANY OF THE OPTIONS
 *DIMENSION DOES NOT INCLUDE MOLD FLASH. MOLD FLASH SHALL NOT EXCEED 0.006" (0.152mm) PER SIDE
 **DIMENSION DOES NOT INCLUDE INTERLEAD FLASH. INTERLEAD FLASH SHALL NOT EXCEED 0.010" (0.254mm) PER SIDE

S16 (WIDE) 0396

TYPICAL APPLICATIONS

Positive Doubler with Regulation

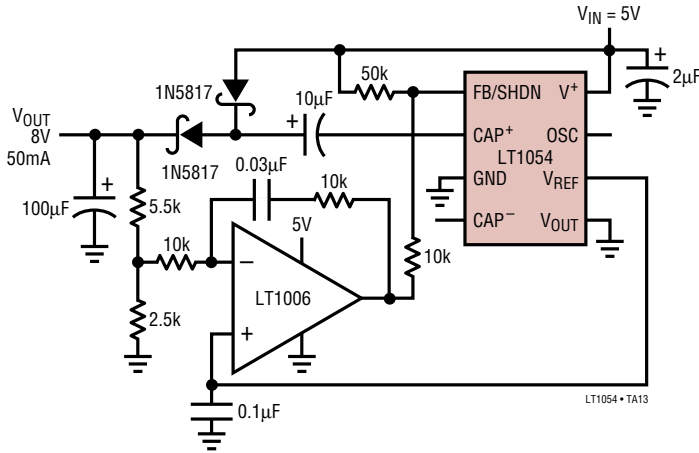

Negative Doubler with Regulator

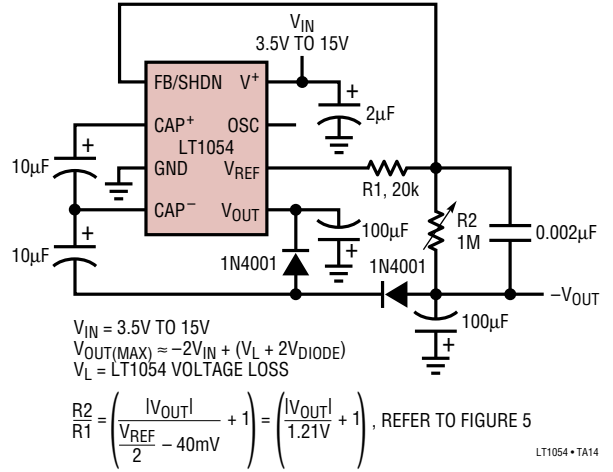

THE TYPICAL APPLICATIONS CIRCUITS WERE VERIFIED USING THE STANDARD LT1054. FOR S8 APPLICATIONS ASSISTANCE IN ANY OF THE UNUSUAL APPLICATIONS CIRCUITS PLEASE CONSULT THE FACTORY

RELATED PARTS

PART NUMBER	DESCRIPTION	COMMENTS
LTC1144	Switched-Capacitor Voltage Converter	Wide Input Voltage Range, 2V to 18V
LTC1514/LTC1515	Step-Up/Step-Down Switched Capacitor DC/DC Converters	Regulated 5V Doublers
LT1611	Micropower Inverting DC/DC Converter	150mA Output
LT1614	Micropower Inverting DC/DC Converter	250mA Output