

AN-9745

Design Guide for TRIAC Dimmable LED Driver Using FL7730

Introduction

An LED has become a promising light source for replacing conventional lighting systems, such as fluorescent and incandescent lights. Especially in the conventional TRIAC dimmer infrastructure, there has been much research into development of an LED bulb compatible with TRIAC dimmers. Because the incandescent light source consumes a hundred watt with short life time, an LED bulb can be the excellent substitute with considerably less power dissipation and longer life.

The biggest recent issue of TRIAC dimmable LED bulb is dimmer compatibility. The conventional TRIAC dimmer was originally designed to handle hundreds of watts induced by incandescent bulbs. An LED bulb consuming less than 20 W should interact with those dimmers composed of high-power devices. If the interaction between dimmer and LED bulb is not stabilized, visible flicker is perceptible.

To manage the interaction without flicker, some requirements for dimmer operation need to be considered. TRIAC dimmer needs latching current at firing and holding current during TRIAC turn-on after firing. If those two currents are not met, TRIAC dimmer misfires and LED light flickers. Figure 1 shows the connection of TRIAC dimmer and LED bulb. As shown in Figure 2, the TRIAC dimmer blocks input line in the beginning of line cycle, then connects input line and LED bulb after firing. The TRIAC dimmer turns off if latching or holding current flowing through the dimmer is inadequate, as shown in Figure 3.

The latching and holding currents are different from dimmer models. The typical range of latching and holding currents is around 5 ~ 50 mA. Those operating requirement do not cause problems using incandescent bulbs due to high power consumption. An LED bulb with less than 20 W output power cannot maintain this amount of current over the whole line cycle.

This application note provides a practical guideline of TRIAC dimmable LED bulb board design. Passive and active bleeder design guides detail how to maintain latching and holding current without visible flicker. Active damper design improves efficiency by minimizing the count of external components. The input filter design section covers the effect of filter components on PF, THD, and EMI.

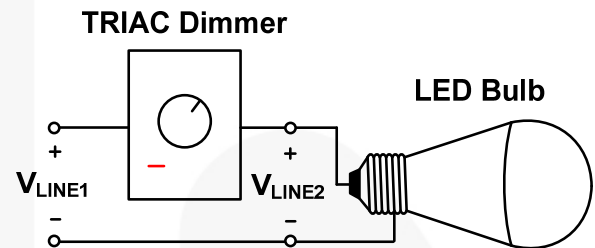

Figure 1. TRIAC Dimmer and LED Bulb

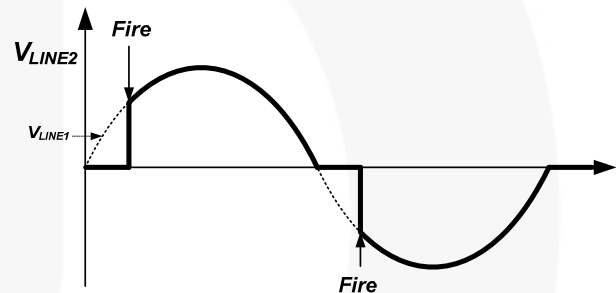

Figure 2. Dimmer Operation with Adequate Latching / Holding Current

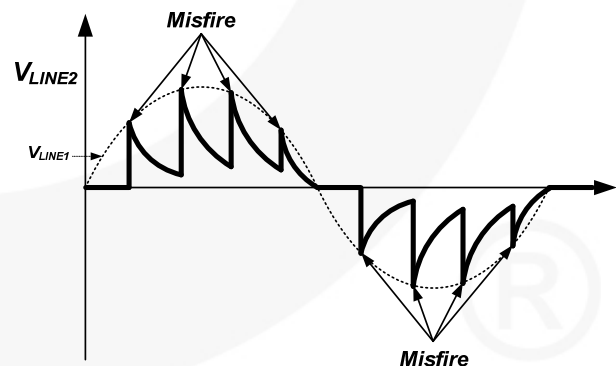

Figure 3. Dimmer Operation with Inadequate Latching / Holding Current

1. Passive Bleeder Design

The passive bleeder is designed to supply latching and holding current to eliminate misfire and flicker. Figure 4 shows a board schematic using a passive bleeder.

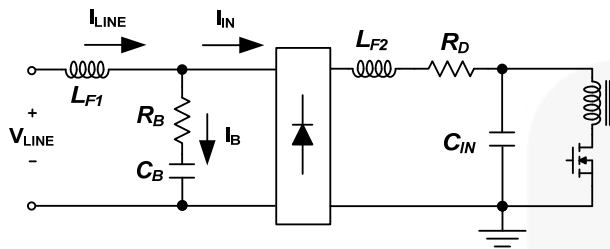

Figure 4. LED Driver Schematic with Passive Bleeder

A passive bleeder is composed of a resistor (R_B) and a capacitor (C_B). L_{F1} and L_{F2} are input filter inductors. C_{IN} is input filter capacitor and R_D is damper resistor.

In dimmable board design, a resistor (ex. R_B , R_D) needs to be connected in series with a capacitor (ex. C_B , C_{IN}) in case that the capacitor is located in between input lines. Without the series resistor, a large voltage and current spike occurs due to the quickly charged energy in the capacitor at dimmer firing. The current spike can damage the TRIAC dimmer, especially when LED bulbs are connected in parallel with the dimmer because the sum of the current spike from each LED bulb can be over the rated current of the TRIAC dimmer. Current ringing after the current spike can also cause the TRIAC dimmer to misfire due to negative current of less than the holding current in the oscillation. The voltage spike can destroy external components if it is over the rated breakdown voltage.

The passive bleeder includes a hundreds-of-nF capacitor (C_B) to provide latching and holding current. To remove the voltage and current spike described above, a bleeder resistor (R_B) is necessary to dampen the spike.

1.1 Passive Bleeder Capacitor (C_B) Selection

The capacity of C_B determines the bleeder current to retain TRIAC turn-on. In terms of TRIAC dimming, bigger C_B has better stability in dimming control due to large bleeder current. Figure 5 and Figure 6 show the line current of small and large bleeder capacitors. The input current (I_{IN}) is the current from the flyback converter behind the bridge diode. I_{IN} is in-phase with line voltage by power factor correction controlled by FL7730. I_B is bleeder current and line current (I_{LINE}) is the sum of I_{IN} and I_B .

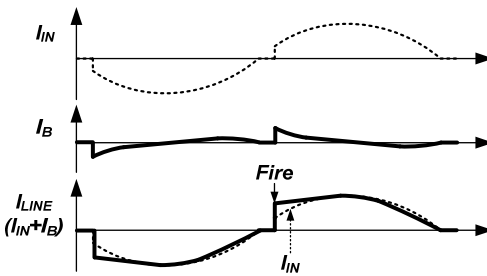

Figure 5. Line Current, Small Bleeder Capacitor (C_B)

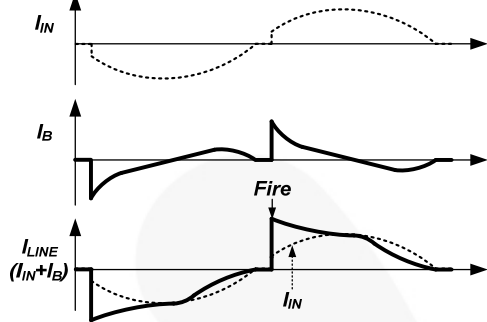

Figure 6. Line Current, Large Bleeder Capacitor (C_B)

I_{LINE} should be higher than latching and holding current because I_{LINE} directly flows through the TRIAC dimmer. In Figure 5, I_{LINE} at firing is not large enough due to the small C_B . The TRIAC dimmer can misfire right after firing, as shown in Figure 3. In Figure 6, I_{LINE} is higher at dimmer firing with the large C_B , which can maintain normal turn-on state of TRIAC, as shown in Figure 2. Therefore, a large C_B maintains dimmer firing better than a small C_B by supplying higher I_B .

However, a large C_B has a drawback in PF, THD, and efficiency. Table 1 shows the system performance comparison between 100 nF and 220 nF C_B . C_B has a significant influence on PF and power dissipation in R_B . Compared to 100 nF C_B , the 220 nF C_B seriously drops PF and increases power dissipation of R_B due to the larger charging and discharging current of C_B .

Table 1. C_B Effect on System Performance

TEST CONDITION: $V_{IN} = 230 V_{AC}$, $P_{OUT} = 8 W$, $R_B = 2 k\Omega$			
	PF	THD	P_D in R_B
C_B [100 nF]	0.93	13%	162 mW
C_B [220 nF]	0.85	11%	684 mW

Therefore, TRIAC dimming control and PF require balanced trade-off when selecting C_B in the passive bleeder. Especially in high-line bulb with high PF requirements; these two factors can make finding the proper C_B a challenge. In the C_B selection, the first step is to see I_B during dimmer firing by changing C_B to check if there is any misfire at dimmer firing due to inadequate I_B . In the range of C_B without abnormal operation in dimmer firing, choose the minimum C_B for higher PF and efficiency. The EMI is not affected by C_B because R_B is connected in series and interrupts noise filtering by C_B .

1.2 Passive Bleeder Resistor (R_B) Selection

R_B is the damper for reducing the spike current caused by quick charging of C_B at firing. Figure 7 shows line current with excessively large R_B . Too large R_B dampens I_B too much and limits I_B less than latching current at firing. Then, the TRIAC dimmer can misfire right after firing so that visible flicker is appears.

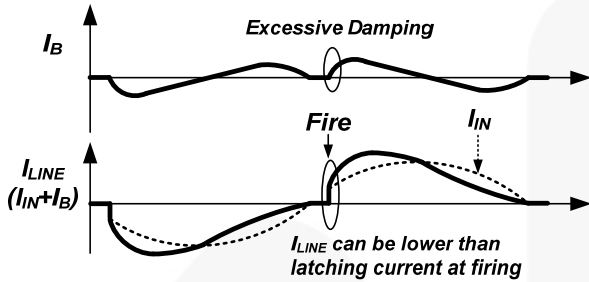

Figure 7. Line Current with Excessively Large R_B

Figure 8 shows I_{LINE} with excessively small R_B . If R_B is too small, R_B doesn't fully dampen the spike current and ringing current occurs. The ringing current fluctuates under the negative I_B , which causes misfire of the TRIAC dimmer and visible flicker.

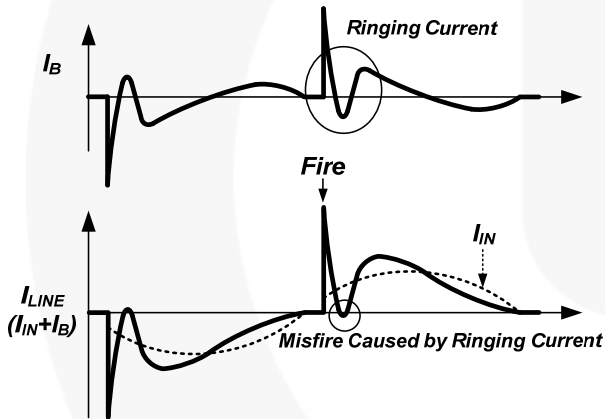

Figure 8. Line Current with Excessively Small R_B

Another consideration in R_B selection is power loss. Table 2 compares system performance using two different bleeder resistors. In the system specification, R_B doesn't affect PF and THD; however, large R_B makes increases power dissipation in R_B .

Table 2. R_B Effect on System Performance

TEST CONDITION: $V_{in} = 230 V_{AC}$, $P_{OUT} = 8 W$, $C_B = 100 nF$			
	PF	THD	P_D IN R_B
R_B [1 k Ω]	0.93	13%	100 mW
R_B [2 k Ω]	0.93	13%	162 mW

In R_B selection, the excessively large and small R_B values should be found first. Then, the minimum R_B can be selected in the proper range of R_B for better efficiency.

2. Active Bleeder Design

Another method to maintain TRIAC holding current is active bleeding technique. The active bleeder can cover a wider range of TRIAC turn-on in a line input cycle compared to passive bleeder. The proposed active bleeder retains TRIAC holding current by regulating input current, which minimizes power loss in the bleeder circuit.

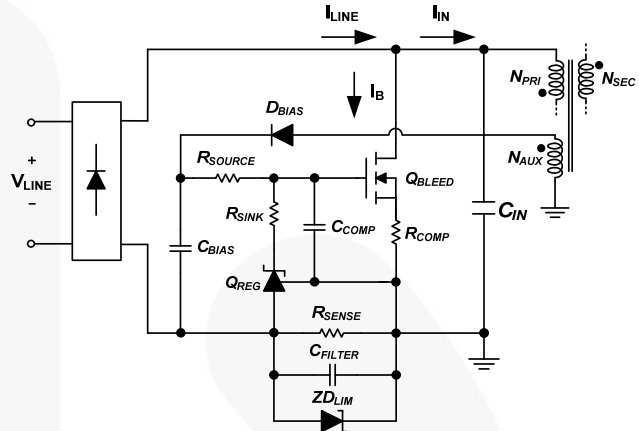

Figure 9. Active Bleeder Schematic

In Figure 9, I_{LINE} is the sum of I_B (active bleeder current) and I_{IN} (flyback input current). R_{SENSE} is sensing resistor detecting line current, I_{LINE} . C_{FILTER} is the filter capacitor to filter switching noise at R_{SENSE} voltage. Q_{REG} is a shunt regulator, such as KA431. At dimmer firing, a large current spike causes a large voltage drop at R_{SENSE} . ZD_{LIM} limits R_{SENSE} voltage to protect reference block of Q_{REG} . Biasing current to drive Q_{BLEED} (bleeder MOSFET) as a linear regulator is supplied by auxiliary winding. The biasing circuit consists of D_{BIAS} and C_{BIAS} . The gate of Q_{BLEED} is controlled by the C_{BIAS} biasing voltage and cathode of Q_{REG} . The amount of driving current is limited by R_{SOURCE} and R_{SINK} . C_{COMP} reduces response of the regulation loop. R_{COMP} compensates control loop as a negative feedback resistor.

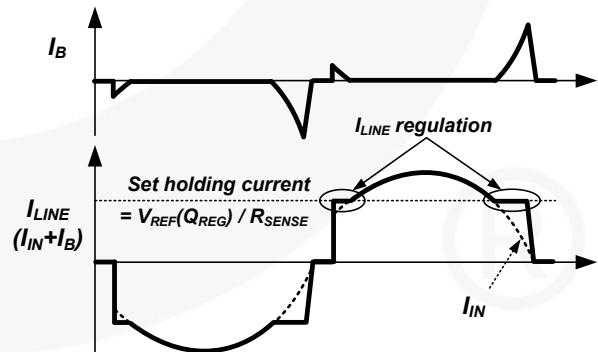

Figure 10. Line Current Using Active Bleeder

The functional operation is shown in Figure 10. In this active bleeder, V_{GS} (gate-source voltage) of Q_{BLEED} is increased and I_B becomes higher when R_{SENSE} voltage is less than V_{REF} of Q_{REG} . The holding current is given as:

$$I_{HOLD} = \frac{V_{REF}(Q_{REG})}{R_{SENSE}} \quad (1)$$

In the selection of the I_{HOLD} , there is a trade-off between dimmer compatibility and system efficiency. If I_{HOLD} is set high, the active bleeder is more compatible with more dimmers; but the amount of I_B increases with more power dissipation in the active bleeder.

R_{SOURCE} , R_{SINK} , C_{COMP} , R_{COMP} , and C_{FILTER} have a close relationship with the feedback response of the active bleeder. Smaller resistance (R_{SOURCE} , R_{SINK} , R_{COMP}) and capacitance (C_{COMP} , C_{FILTER}) increase the speed of the feedback loop. If feedback loop is too fast, I_B oscillates with a large current ripple.

The operation of the active bleeder should be synchronized with the normal IC operation period. When the IC is in an abnormal condition, such as an LED short and open, there is no I_{IN} due to shutdown gate signal. If active bleeder is still activated in this abnormal condition, the active bleeder should maintain holding current without I_{IN} and the power dissipation in the active bleeder is very high and Q_{BLEED} is thermally destroyed. Therefore, the biasing current should come from the auxiliary winding. Then, the active bleeder can be disabled when switching is shut down.

Figure 11 is a design example of an active bleeder. Probe ground is connected to V_{REF} of the shunt regulator (KA431). C1 is the R_{SENSE} voltage and C2 is the input voltage. C3 is the bleeder MOSFET source voltage, which is proportional to bleeder current. C4 is current probed line current.

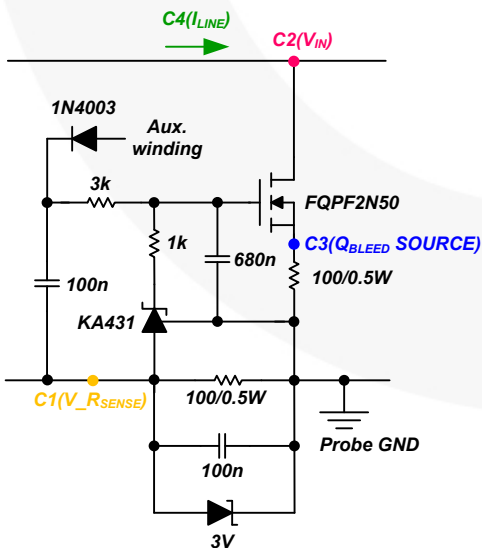

Figure 11. Example of Active Bleeder in 8 W Bulb

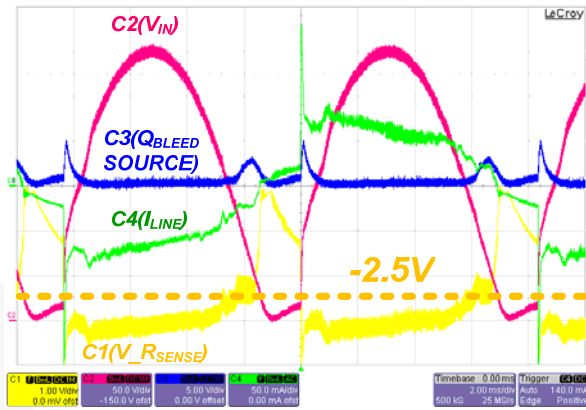

Figure 12. Measured Waveform at High Dimming Angle

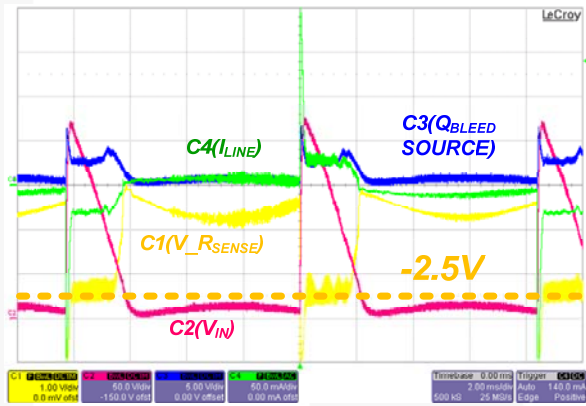

Figure 13. Measured Waveform at Low Dimming Angle

Figure 12 and Figure 13 show the waveforms of the active bleeder at high and low dimming angle. At low dimming angle, output current is reduced by the dimming function in FL7730. The active bleeder should compensate more I_B current due to the reduced I_{IN} (C3). That is why the power dissipation in the active bleeder is in the middle dimming angle range. To check the maximum bleeder temperature, the test condition should be a middle dimming angle and maximum line input voltage.

3. Active Damper Design

A resistive damper is necessary in series with input filter capacitor (C_{IN}) when TRIAC dimmer is fired. At dimmer firing, a large current spike is induced through input line to quickly charge C_{IN} . Without the resistive damper, the large spike creates line current oscillation, causing dimmer misfire and damage to the TRIAC dimmer with the excessive current. While the damper resistor suppresses the spike current, the power loss in the damper resistor is very high. The damper resistor not only dampens the spike current, but also handles the input current from the flyback.

Therefore, Fairchild’s proprietary active damper is proposed to reduce the power loss with minimized external components. In Figure 14, R_{AD} is the active damper resistor and Q_{AD} is damper MOSFET to reduce power loss of R_{AD} . R_D and C_D are delay circuit components and D_D is reset diode to discharge C_D .

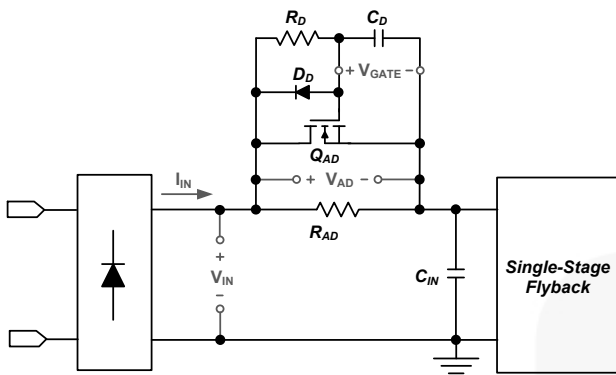

Figure 14. Active Damper Schematic

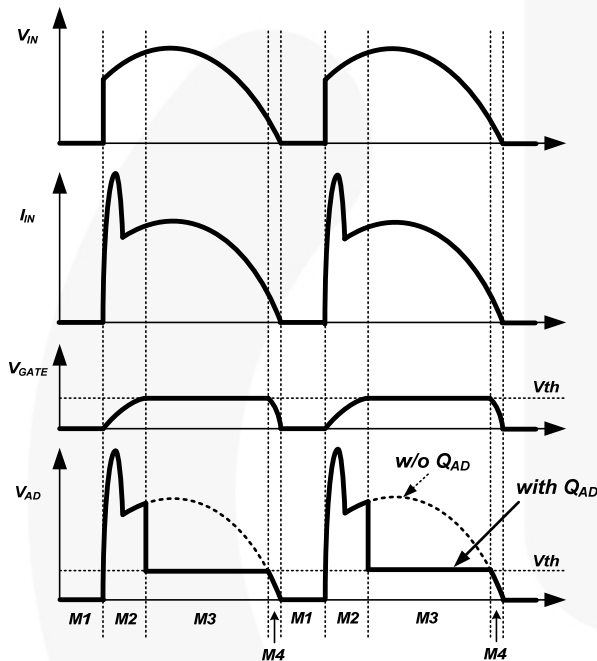

Figure 15. Active Damper Waveforms

Figure 15 shows the operational waveforms of the active damper. Mode analysis is as according to the sequence:

- M1: Dimmer turn-off period; Q_{AD} turns off.
- M2: Dimmer is fired and spike current occurs. V_{GATE} is gradually increased by the delay circuit (R_D and C_D)
- M3: Q_{AD} turns on by the charged V_{GATE} . V_{AD} is regulated as V_{TH} of Q_{AD} .
- M4: C_D is discharged by D_D and V_{GATE} is reset for the next line cycle. The discharging current path is $D_D - R_{AD} - C_D$.

During M3 period, Q_{AD} can considerably reduce power loss in R_{AD} by regulating V_{AD} as its threshold voltage (V_{TH}). Table 3 shows power dissipation of passive and active dampers. The power loss of active damper is much lower than passive damper resistor. At low line (110 V_{AC}), input current is high and the damper resistor handles the large

current. Therefore, the active damper is strongly recommended at low line model.

Table 3. Passive vs. Active Damper Power Loss

$P_{OUT} = 8W$	Damper Power Dissipation [mW]	
	$V_{IN}: 110 V_{AC}$	$V_{IN}: 220 V_{AC}$
PASSIVE DAMPER, 200 Ω	1200	290
ACTIVE DAMPER, 200 Ω + FQN1N50C ($V_{TH}: 2\sim 4 V$)	278	161
ACTIVE DAMPER, 200 Ω + FDD10N20LZ ($V_{TH}: 1\sim 2.5 V$)	171	113

3.1 Active Damper Resistor (R_{AD}) Selection

A voltage and current spike should be checked first when selecting R_{AD} . Voltage spikes can damage the MOSFET and filter capacitor over the rated voltage. Current spikes create current ringing at dimmer firing. As shown in Figure 16, I_{IN} ringing occurs at firing with small R_{AD} . This ringing current drops I_{IN} and the lowered I_{IN} can lead to misfire of the dimmer and visible flicker. Also, a large peak current spike by using small R_{AD} might damage the TRIAC dimmer, especially when the dimming LED bulbs are connected in parallel. Therefore, check points when selecting R_{AD} are:

- Voltage spike (should be less than the part's breakdown voltage.)
- Current spike (should be less than the TRIAC dimmer's rated current. If considering connecting bulbs in parallel, the current spike should be lower inversely proportional to the number of LED bulbs.)
- Current ringing (check the dropped I_{IN} at firing if it is enough higher than TRIAC holding current.)

After checking the above considerations, choose the minimum R_{AD} to maximize efficiency.

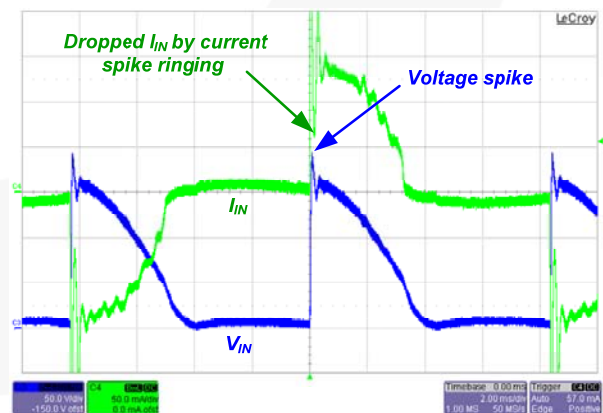
Figure 16. V_{IN} and I_{IN} with Small Damper Resistor (R_{AD})

3.2 Active Damper MOSFET (Q_{AD}) Selection

The maximum V_{AD} should be less than the breakdown voltage of Q_{AD} . After selecting R_{AD} , maximum V_{AD} can be checked at 90° dimming angle and the highest input line

voltage. Then, choose proper Q_{AD} with breakdown voltage margin. 1~2 A current rating is enough in the 8W LED bulb. As shown in Table 3, logic-level MOSFET with low threshold voltage can additionally reduce power loss because the regulated V_{AD} is Q_{AD} threshold voltage.

3.3 Active Damper Diode (D_D) Selection

The active damper diode discharges C_D to reset V_{GATE} . Diode with 1A rated forward current is enough to discharge C_D . Same as the Q_{AD} selection, maximum V_{AD} at 90° dimming angle and the highest input line voltage should be checked first to select D_D reverse voltage specification.

3.4 Active Damper Delay Circuit (R_D , C_D) Selection

The delay circuit (R_D , C_D) should create a long enough delay time before Q_{AD} turns on to let R_{AD} dampen the current spike. The worst case for the spike current is 90° dimming angle. Spike current ringing needs to be checked first at 90° dimming angle to determine how long the spike current is dampened. Then, adjust R_D and C_D to guarantee the dampened period. The recommended C_D and R_D values are hundreds of nF and tens of kΩ. If C_D is too large and R_D is very small, D_D cannot fully discharge C_D in M4, as shown in Figure 15.

Design Example

Figure 17 shows the design example of the active damper in an 8W LED bulb system. As shown in Figure 18 and Figure 19, the delay by 80 kΩ R_D and 100 nF C_D is around 1ms. During the delay, 220 Ω R_{AD} dampens voltage and current spike without current ringing or dimmer misfire.

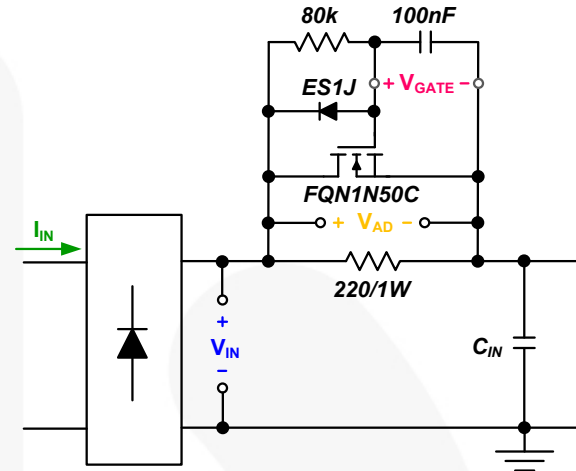

Figure 17. Design Example: Active Damper in 8W Bulb

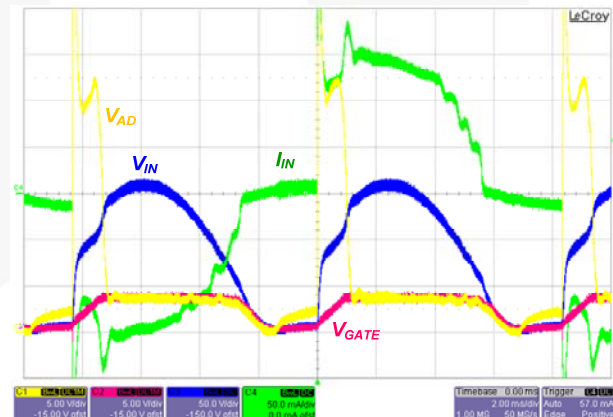

Figure 18. Measured Waveform at High Dimming Angle

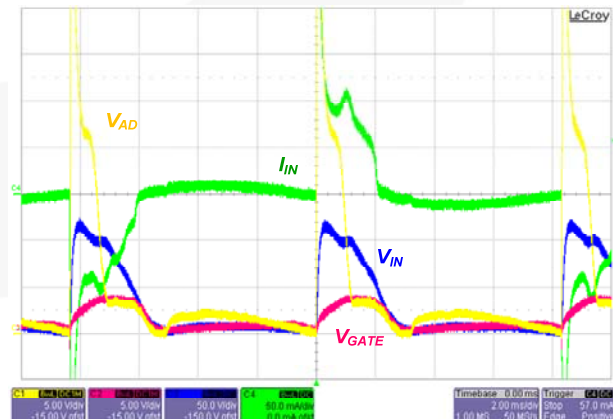

Figure 19. Measured Waveform at Low Dimming Angle

4. Features of FL7730

The FL7730 is an active power factor correction (PFC) controller using single-stage flyback topology. Dimming control with no flicker is implemented by the analog sensing method. Primary-side regulation and single-stage topology reduce external components, such as input bulk capacitor and feedback circuitry to minimize cost. To improve power factor and THD, constant on-time control is utilized with an internal error amplifier and low bandwidth compensator. Precise constant-current control regulates accurate output current, independent of input voltage and output voltage. Operating frequency is proportionally adjusted by output voltage to guarantee DCM operation with higher efficiency and simpler design. FL7730 provides protections such as open-LED, short-LED, and over-temperature protection.

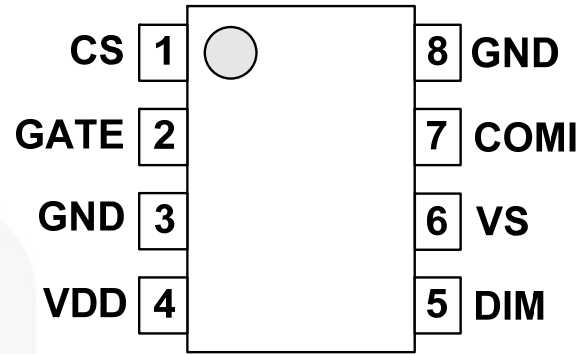

Figure 20. Package Diagram

Table 4. Pin Definitions

Pin #	Name	Description
1	CS	Current Sense. This pin connects a current-sense resistor to detect the MOSFET current for the output-current regulation in constant-current regulation.
2	GATE	PWM Signal Output. This pin uses the internal totem-pole output driver to drive the power MOSFET.
3	GND	Ground
4	VDD	Power Supply. IC operating current and MOSFET driving current are supplied using this pin.
5	DIM	Dimming. This pin controls the dimming operation of the LED lighting.
6	VS	Voltage Sense. This pin detects the output voltage information and discharge time for linear frequency control and constant-current regulation. This pin connects divider resistors from the auxiliary winding.
7	COMI	Constant-Current Loop Compensation. This pin is the output of the transconductance error amplifier.
8	GND	Ground

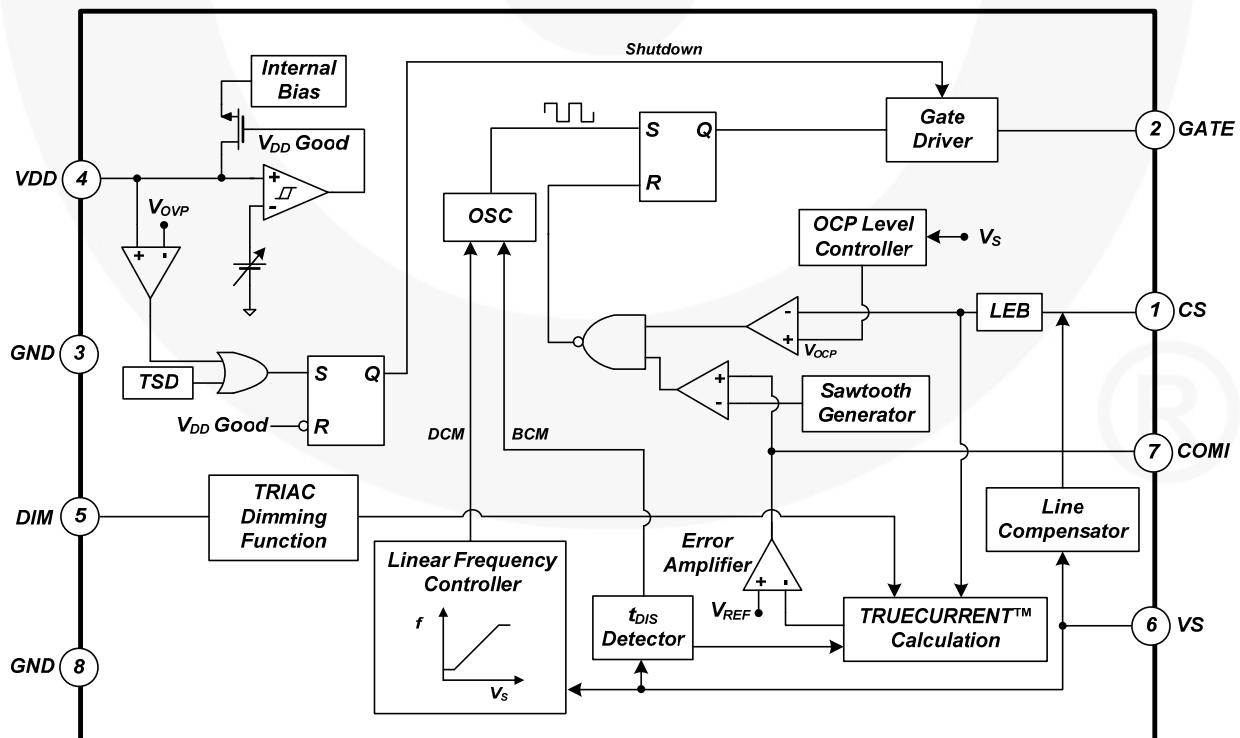

Figure 21. Functional Block Diagram

Design Summary

Figure 22 shows the schematic of the TRIAC dimmable LED driver using FL7730. This schematic is dedicated to low-line voltage (90~140 V_{AC}).

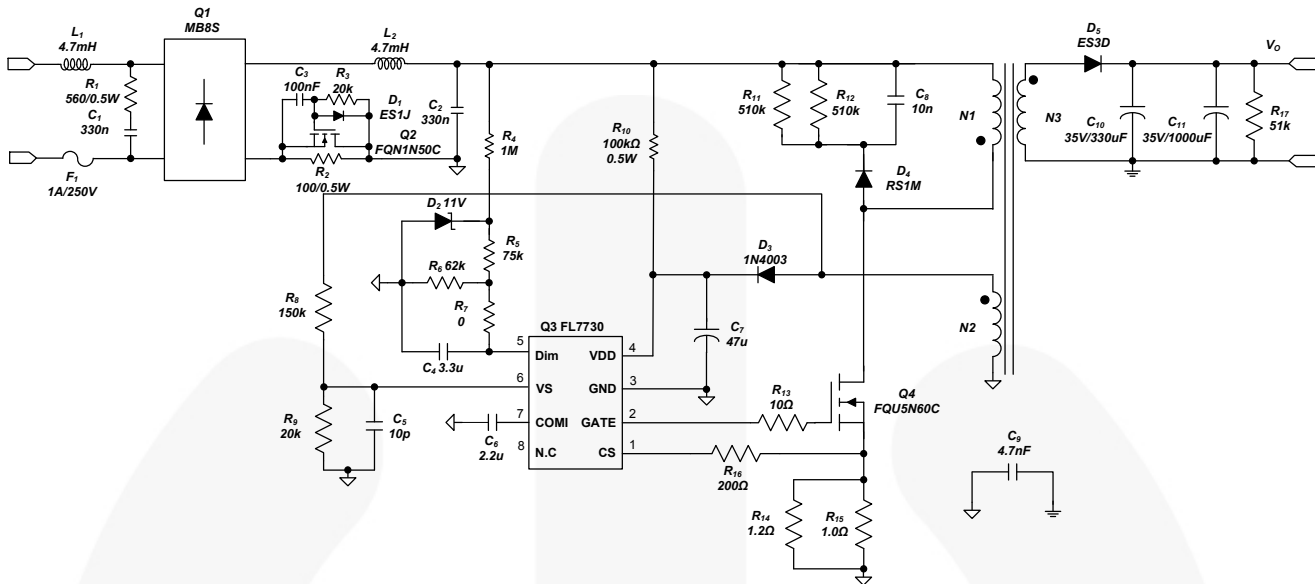

Figure 22. Schematic of TRIAC Dimmable LED Driver Using FL7730 (Low Line: 90~140 V_{AC})

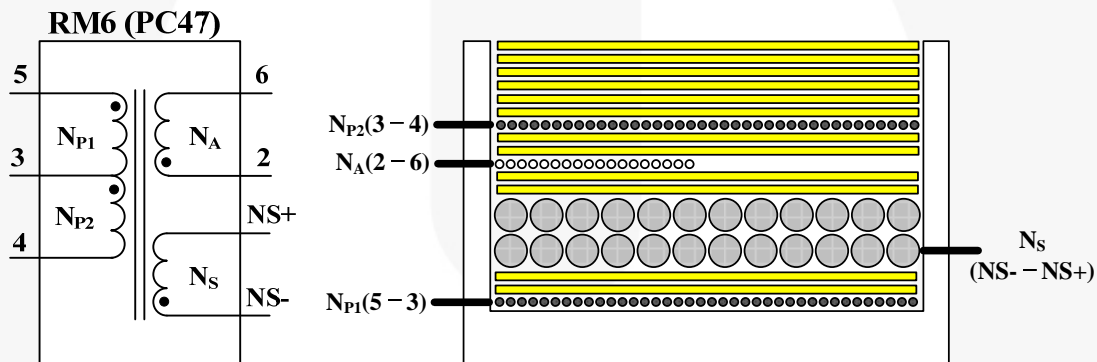

Figure 23. Transformer Structure

Table 5. Winding Specifications

No	Winding	Pin (S → F)	Wire	Turns	Winding Method
1	NP1	5 → 3	0.13φ	38 Ts	Solenoid Winding
2	Insulation: Polyester Tape t = 0.025 mm, 2-Layer				
3	NS	NS- → NS+	0.3φ (TIW)	24 Ts	Solenoid Winding
4	Insulation: Polyester Tape t = 0.025 mm, 2-Layer				
5	NA	2 → 6	0.13φ	18 Ts	Solenoid Winding
6	Insulation: Polyester Tape t = 0.025 mm, 2-Layer				
7	NP2	3 → 4	0.13φ	38 Ts	Solenoid Winding
8	Insulation: Polyester Tape t = 0.025 mm, 6-Layer				

Table 6. Electrical Characteristics

	Pin	Specification	Remark
Inductance	1 – 2	1 mH ±10%	50 kHz, 1 V
Leakage	1 – 2	8 μH	50kHz, 1 V Short All Output Pins

Experimental Verification

The design example with passive bleeder and active damper was experimentally verified in an 8 W LED lighting system.

Figure 24 shows constant current regulation at input voltage and output voltage change. Constant-current deviation in the wide output voltage range from 10 V to 28 V is less than 2.1% at each line input voltage. Line regulation at the rated output voltage (22 V) is less than 3.9%.

Operation waveforms are shown in Figure 25, Figure 26, and Figure 27. In this dimmable board, TRIAC dimmer firing is stabilized without any misfire. FL7730 keeps constant t_{ON} so V_{CS} is in phase with V_{IN} . The maximum spike current of I_{IN} is 1.2 A. Figure 28 shows the dimming curve. RMS input voltage indicates TRIAC dimming angle. LED current is smoothly controlled by the FL7730 dimming function and external circuits, such as the passive bleeder and active damper. Table 7 provides compatibility with common dimmers for a design without visible flicker. Maximum and minimum current vary because each dimmer's maximum and minimum angles are different.

System efficiency is from 80.7% to 82.9% at low line input voltage (90 ~ 140 V_{AC}). The active damper helps improve the efficiency with a compact and inexpensive design solution. Table 8 shows PF and THD in a low line input voltage range of 90~140 V_{AC}. PF is over 0.9 and THD is much less than 30% by constant t_{ON} and linear frequency control in the FL7730.

The performances obtained in the design example show a powerful LED lighting solution with accurate constant current regulation, stable dimming control, high efficiency, high PF, and low THD with low BOM cost.

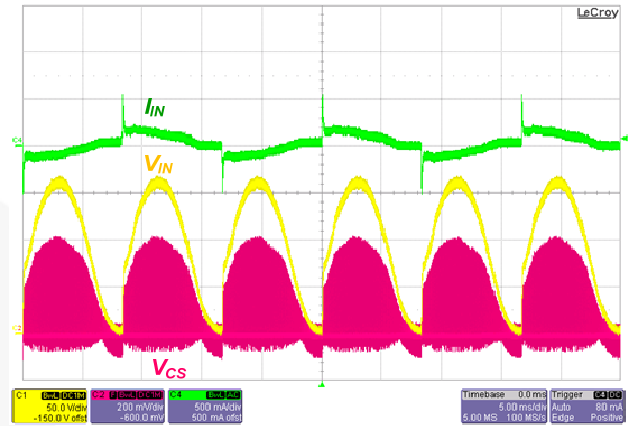

Figure 25. Waveforms at Maximum Dimming Angle

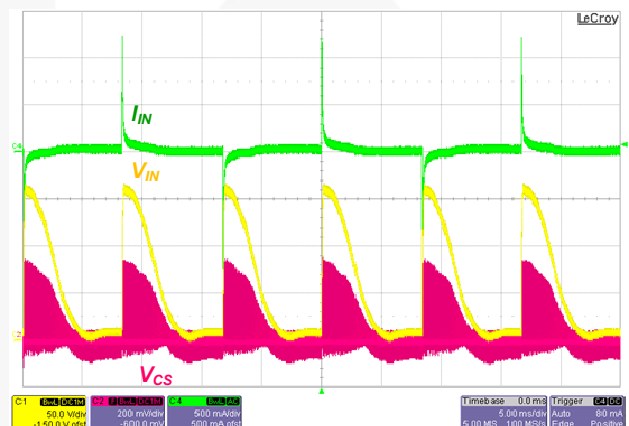

Figure 26. Waveforms at Half Dimming Angle

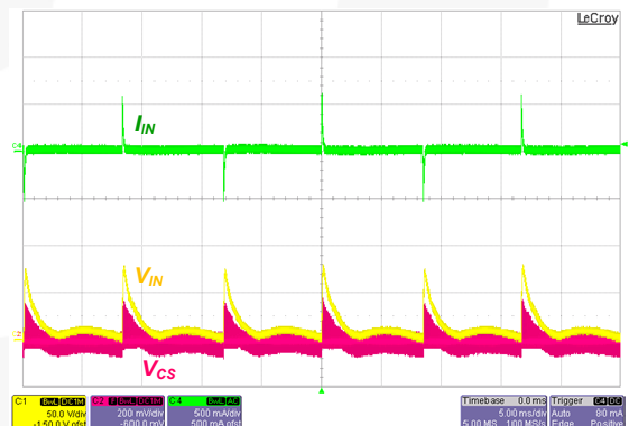

Figure 27. Waveforms at Minimum Dimming Angle

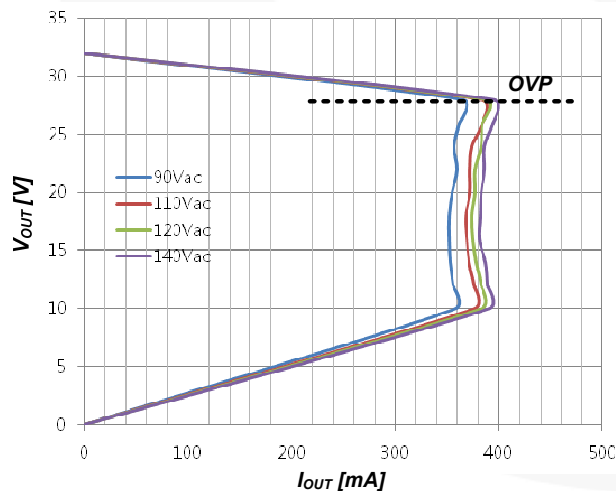

Figure 24. CC Regulation, Measured by CR-Load

Table 7. Dimmer Compatibility

Manufacturer	Dimmer	Maximum Current	Minimum Current	Flicker
LUTRON	S-600P-WH	330 mA	40 mA (12%)	No
LUTRON	CN-600P-WH	328 mA	11 mA (3.4%)	No
LUTRON	GL-600H	365 mA	8 mA (2.2%)	No
LUTRON	TG-603PGH-WH	252 mA	12 mA (4.8%)	No
LUTRON	TG-600PH-WH	333 mA	14 mA (4.2%)	No
LUTRON	LG-600P	327 mA	3 mA (0.9%)	No
LUTRON	CTCL-153PD	320 mA	58 mA (18%)	No
LEVITON	IP106	380 mA	36 mA (9.5%)	No
LEVITON	1C4005	344 mA	0 mA (0%)	No
LEVITON	6631-LW	340 mA	0 mA (0%)	No
Legrand	F 165H	344 mA	3 mA (0.9%)	No

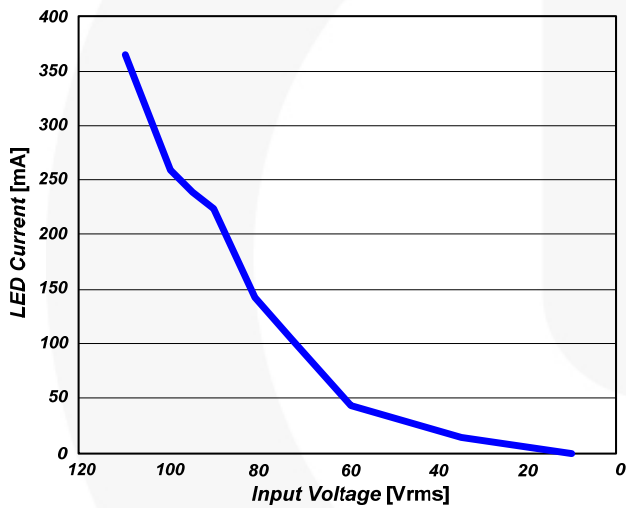

Figure 28. Dimming Curve (Input Voltage vs. LED Current)

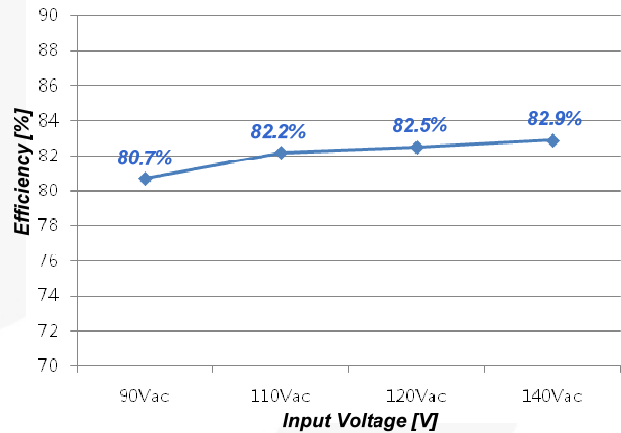

Figure 29. Efficiency

Table 8. Power Factor (PF) and Total Harmonic Distortion (THD)

Input Voltage	Output Current	Output Voltage	PF	THD
90 V _{AC}	360 mA	21.70 V	0.98	7.4%
110 V _{AC}	376 mA	21.77 V	0.96	9.5%
120 V _{AC}	380 mA	21.77 V	0.95	10.4%
140 V _{AC}	386 mA	21.79 V	0.91	12.4%

Related Datasheets

[FL7730MY — Single-Stage Primary-Side-Regulation PWM Controller for PFC and LED Dimmable Driving](#)

[KA431 — Programmable Shunt Regulator](#)

DISCLAIMER

FAIRCHILD SEMICONDUCTOR RESERVES THE RIGHT TO MAKE CHANGES WITHOUT FURTHER NOTICE TO ANY PRODUCTS HEREIN TO IMPROVE RELIABILITY, FUNCTION, OR DESIGN. FAIRCHILD DOES NOT ASSUME ANY LIABILITY ARISING OUT OF THE APPLICATION OR USE OF ANY PRODUCT OR CIRCUIT DESCRIBED HEREIN; NEITHER DOES IT CONVEY ANY LICENSE UNDER ITS PATENT RIGHTS, NOR THE RIGHTS OF OTHERS.

LIFE SUPPORT POLICY

FAIRCHILD'S PRODUCTS ARE NOT AUTHORIZED FOR USE AS CRITICAL COMPONENTS IN LIFE SUPPORT DEVICES OR SYSTEMS WITHOUT THE EXPRESS WRITTEN APPROVAL OF THE PRESIDENT OF FAIRCHILD SEMICONDUCTOR CORPORATION.

As used herein:

1. Life support devices or systems are devices or systems which, (a) are intended for surgical implant into the body, or (b) support or sustain life, or (c) whose failure to perform when properly used in accordance with instructions for use provided in the labeling, can be reasonably expected to result in significant injury to the user.
2. A critical component is any component of a life support device or system whose failure to perform can be reasonably expected to cause the failure of the life support device or system, or to affect its safety or effectiveness.