

# molex® Panel Grounding Clip

## 42172

### FEATURES AND SPECIFICATIONS

#### Features and Benefits

- Provides reliable ground to chassis without fasteners
- Simple to install
- Requires no secondary fasteners
- Accepts single and dual crimps
- Secondary grounding applications only
- Rust-resistant Stainless Steel

#### Physical

Contact: .020" Stainless Steel

#### Reference Information

UL File No.: E126412  
 CSA File No.: LR19980A  
 Designed In: Inches

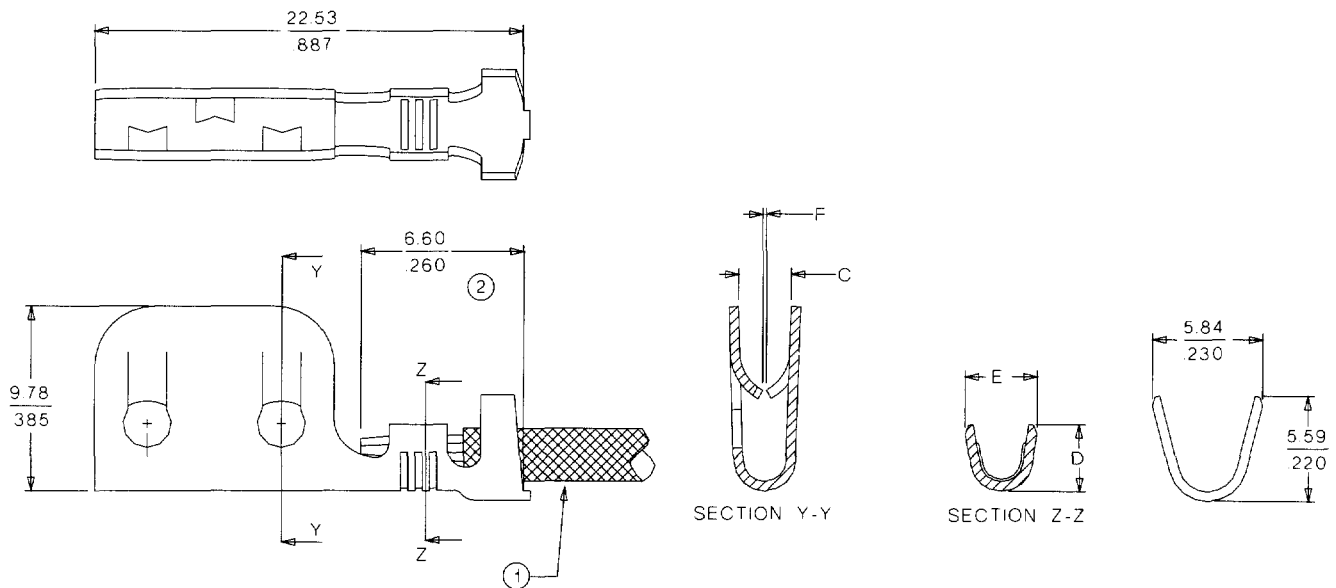
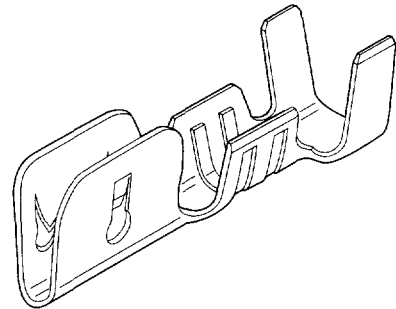

### ORDERING INFORMATION AND DIMENSIONS

Minimum Panel Thickness	Maximum Panel Thickness	Wire Range AWG	Dual Crimp Capabilities	Engineering No.	Order No.	Dimension				Application Tooling Mini-Mac
						C	D	E	F	
0.38 (.015)	0.89 (.035)	14	(2) 16 AWG	42172-CG1	40-06-2025	.110 (2.80)	4.10 (.160)	4.10 (.160)	.004 (0.10)	11-18-2139
0.38 (.015)	0.89 (.035)	14	(2) 16 AWG	42172-DD1	40-06-2018	.110 (2.80)	4.10 (.160)	4.10 (.160)	.004 (0.10)	11-18-2139
0.38 (.015)	0.89 (.035)	16-18	(2) 18 AWG, or (1) 18 and (1) 16 AWG	42172-G1	40-06-2024	.110 (2.80)	3.60 (.140)	3.80 (.150)	.004 (0.10)	11-18-2139
0.38 (.015)	0.89 (.035)	16-18	(2) 18 AWG, or (1) 18 and (1) 16 AWG	42172-D1	40-06-2019	.110 (2.80)	3.60 (.140)	3.80 (.150)	.004 (0.10)	11-18-2139
0.38 (.015)	0.89 (.035)	14	(2) 16 AWG	42172-AA1	40-06-2014	.110 (2.80)	4.10 (.160)	4.10 (.160)	.008 (0.20)	11-18-2139
0.38 (.015)	0.89 (.035)	16-18	(2) 18 AWG, or (1) 18 and (1) 16 AWG	42172-A1	40-06-2003	.110 (2.80)	3.60 (.140)	3.80 (.150)	.008 (0.20)	11-18-2139
0.51 (.020)	0.76 (.030)	16-18	(2) 18 AWG, or (1) 18 and (1) 16 AWG	42172-F1	40-06-2017	.110 (2.80)	3.60 (.140)	3.80 (.150)	.015 (0.38)	11-18-2139
0.89 (.035)	1.27 (.050)	14	(2) 16 AWG	42172-BB1	40-06-2015	.130 (3.30)	4.10 (.160)	4.10 (.160)	.025 (0.64)	11-18-2139
0.89 (.035)	1.27 (.050)	16-18	(2) 18 AWG, or (1) 18 and (1) 16 AWG	42172-B1	40-06-2005	.130 (3.30)	3.60 (.140)	3.80 (.150)	.025 (0.64)	11-18-2139
1.52 (.060)	1.91 (.075)	14	(2) 16 AWG	42172-CC1	40-06-2016	.130 (3.30)	4.10 (.160)	4.10 (.160)	.050 (1.27)	11-18-2139
1.52 (.060)	1.91 (.075)	16-18	(2) 18 AWG, or (1) 18 and (1) 16 AWG	42172-C1	40-06-2013	.130 (3.30)	3.60 (.140)	3.80 (.150)	.050 (1.27)	11-18-2139

Specialty Connectors

