

MAX3601

Laser Driver for Projectors

General Description

The MAX3601 laser driver for pico projectors supports video imaging with red, blue, and green lasers. Each output includes two 8-bit digital-to-analog converters (DACs) with programmable gain and up to 400mA driving capability per channel. DAC A has a full-scale current up to 320mA, while DAC B has full-scale current up to 80mA. All three channels can be combined into a single channel with up to 1.2A drive capability.

Maxim's patented technology allows pulsed current to operate lasers efficiently while reducing speckle. This feature operates from the video data clock. The driver is available in a 3.0mm x 3.5mm, 42-bump wafer-level package for commercial applications and a 5mm x 5mm, 40-pin TQFN package for industrial and automotive applications.

Applications

- RGB Pico Laser Projector
- Laser Light Source for LCOS Projectors
- High-Current LED or Laser Pulse Generator

Ordering Information appears at end of data sheet.

Benefits and Features

- ◆ **Integrates Three Current-Output Laser Drivers**
 - ◇ **Compatible with Most Red, Blue, and Green Lasers**
 - ◇ **8-Bit Video DACs, DC to 167MHz operation**
 - ◇ **Patented Pulsing Feature Reduces Laser Speckling**
 - ◇ **1ns Output Switching Time**
 - ◇ **Pulse Switching Speed Enhancer**
- ◆ **Minimizes PCB Area with Functional Integration**
 - ◇ **SPI or I²C Serial Port Control**
 - ◇ **1.8V to 3.3V Operation**
 - ◇ **8-Bit Gain Adjustment**
 - ◇ **Programmable Pulse Current**
 - ◇ **42-Bump WLP (3.0mm x 3.5mm) and 40-Pin TQFN (5mm x 5mm) Packages**
 - ◇ **Integrated Temperature Sensor**
- ◆ **Low Power Requirements**
 - ◇ **< 80mW for Black Video Images**
 - ◇ **Output Disable Using Video Marker**
 - ◇ **Output Voltage Sensor**
- ◆ **Laser Enable Function Supports Safety Compliance**

Simplified Functional Diagram

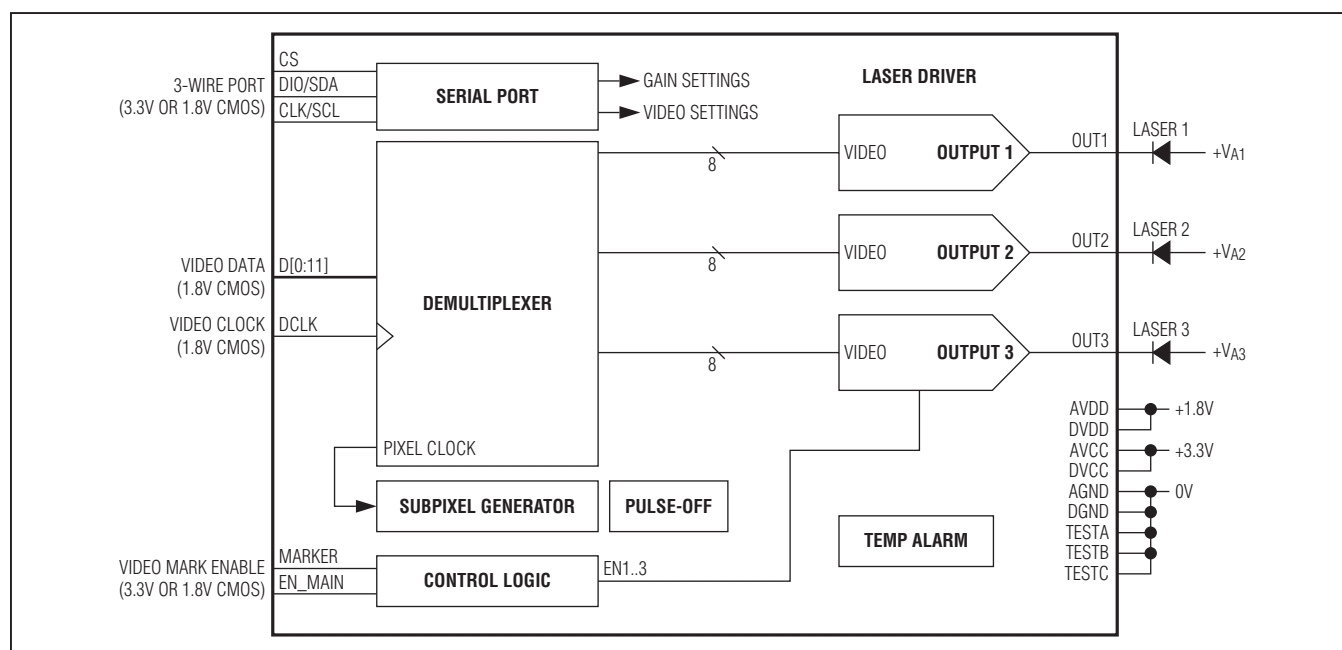

For related parts and recommended products to use with this part, refer to: www.maximintegrated.com/MAX3601.related

For pricing, delivery, and ordering information, please contact Maxim Direct at 1-888-629-4642, or visit Maxim Integrated's website at www.maximintegrated.com.

MAX3601

Laser Driver for Projectors

Typical Operating Circuits (continued)

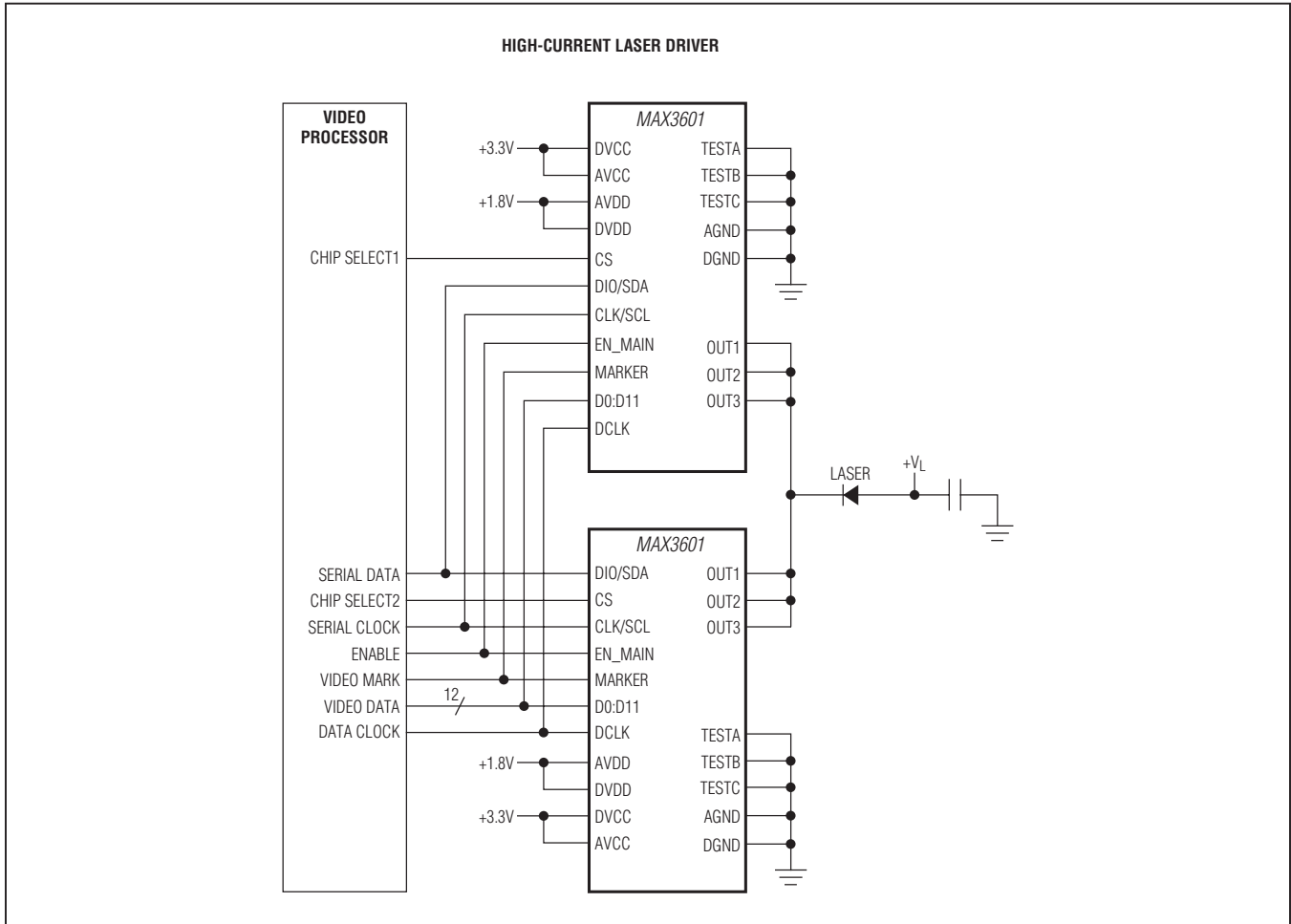

Ordering Information

PART	TEMP RANGE	PIN-PACKAGE
MAX3601GTL+	-40°C to +105°C	40 TQFN-EP*
MAX3601CWO+	0°C to +70°C	42 WLP

+Denotes a lead (Pb)-free/RoHS-compliant package.

*EP = Exposed pad.

Package Information

For the latest package outline information and land patterns (footprints), go to www.maximintegrated.com/packages. Note that a "+", "#", or "-" in the package code indicates RoHS status only. Package drawings may show a different suffix character, but the drawing pertains to the package regardless of RoHS status.

PACKAGE TYPE	PACKAGE CODE	OUTLINE NO.	LAND PATTERN NO.
40 TQFN-EP	T4055N+1	21-0140	90-0103
42 WLP	W423E3+1	21-0440	Refer to Application Note 1891