

IPT 00 A Front Panel Mount Square Flange Receptacle with Backshell

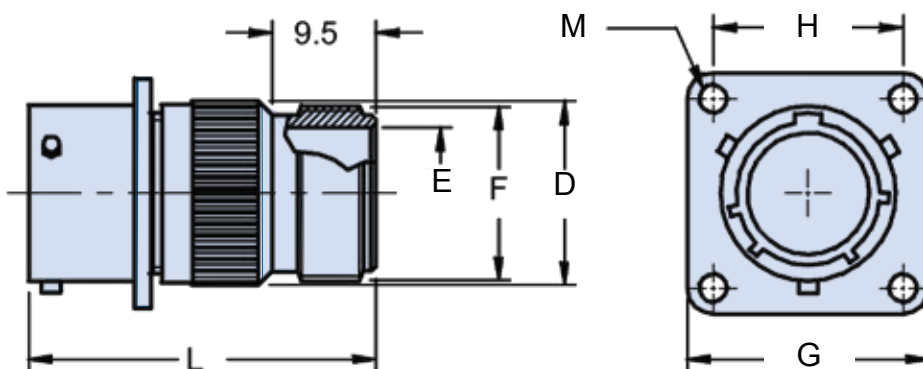
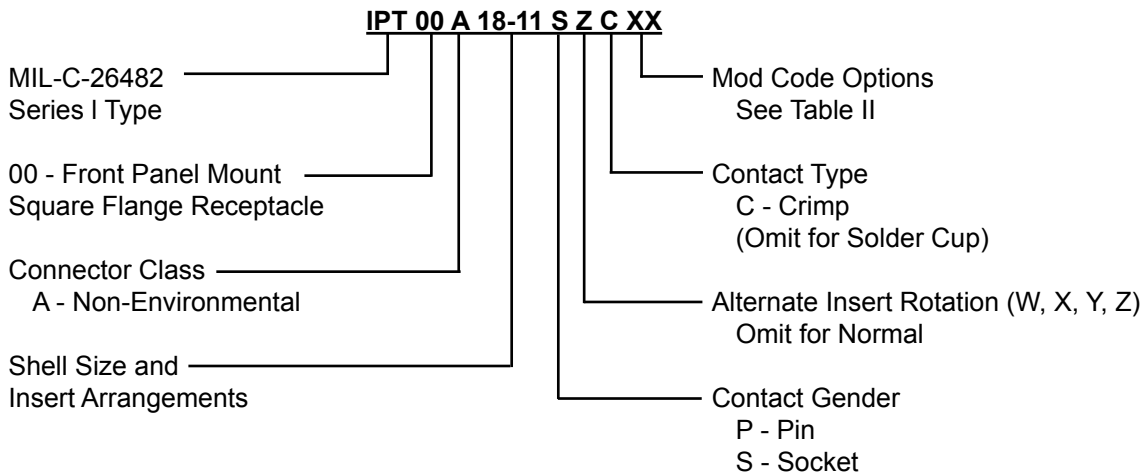

APPLICATION NOTES

1. Front panel wall mount receptacle with backshell for the attachment of additional accessories; through mounting holes.
2. Connector Class "A" (non-environmental)—no grommet supplied.
3. Standard materials configuration consists of aluminum alloy with stainless steel coupling pins.
4. Standard contact material consists of copper alloy with gold plating over nickel.
5. A broad range of other front and rear connector accessories are available. See our website and/or contact factory for complete information.
6. Standard insert is high insulation synthetic rubber.

IPT 00 A
Front Panel Mount Square Flange Receptacle
with Backshell



TABLE I: DIMENSIONS

Shell size	D Max.	E min.	F Thread in inches	G ±0.4	H ±0.1	L Max.	M ±0.12
8	15.00	7.55	.5000 - 28 UNEF	20.6	15.10	40.9	3.04
10	18.20	10.70	.6250 - 24 UNEF	23.8	18.25	40.9	3.04
12	21.20	13.85	.7500 - 20 UNEF	26.2	20.60	40.9	3.04
14	24.60	16.85	.8750 - 20 UNEF	28.6	23.00	40.9	3.04
16	27.60	20.00	1.0000 - 20 UNEF	31.0	24.60	40.9	3.04
18	30.90	22.30	1.1875 - 18 UNEF	33.3	27.00	40.9	3.04
20	33.80	25.75	1.1875 - 18 UNEF	36.5	29.35	45.0	3.04
22	37.10	28.80	1.4375 - 18 UNEF	39.7	31.75	45.0	3.04
24	40.25	32.00	1.4375 - 18 UNEF	42.9	39.40	45.0	3.73

TABLE II: MODIFICATION CODES

Shell Finish (Omit for Standard Cad/Olive Drab Finish)	Assembly with Accessories (Omit for Standard Version)
F2 - Bright Nickel Plating (RoHs)	Key Polarization (Omit for N version) W, X, Y, Z = Alternates
F6 - Black Electrodeposited Paint (RoHs)	N0 - Connector Less Backshell
F7 - Black Zn-Co Plating (RoHs)	GXXX - Custom Designed Connector
F8 - Olive Drab Zn-Co Plating	

STANDARD FINISHES (For QQ-A-591 Aluminum Shells)

Requirements	IAW RoHS			Not IAW RoHS	
	F2 Electrolytic Nickel	F6 Black Non Conductive	F7 Black Conductive	G3 Cadmium with Olive Drab Passivation	F8 Zinc Cobalt with Olive Drab Passivation
Thermal Shock	-40°C + 100°C	-55°C + 125°C	-55°C + 125°C	-55°C + 125°C	-40°C + 100°C
Salt Spray After Thermal Shock	24 hour	500 hour	500 hour	500 hour	200 hour
Electical Conductivity	Very Good	NO	Very Good	Very Good	Good
Abrasion Resistance	Very Good	Very Good	Good	Very Good	Good