

Absolute Maximum and Minimum Ratings ¹⁾				
Symbol	Rating	Value		Unit
		min.	max.	
V _{sup}	Driver supply voltage	–	18	V
V _j	Input signal voltage	– 0,3	V _{sup} + 0,3	V
V _{isol}	Input–Output	–	2500	V–
T _{case}	Case temperature ²⁾	– 40	+ 85	°C
T _{stg}	Storage temperature	– 40	+ 85	°C

Operating Conditions				
Symbol	Rating	Value		Unit
		min.	max.	
V _{sup}	Driver supply voltage	8	15	V
V _{iL}	Logic 0 input voltage (LOW)	–	0,14 · V _{sup}	V
V _{iH}	Logic 1 input voltage (HIGH)	0,86 · V _{sup}	–	V
f	Operating frequency	0	50 ⁴⁾	kHz
t _p	Input pulse duration	0,5 ⁵⁾	–	µs
t _{p(off)}	Input pulse off-time	0,5 ⁵⁾	–	µs

Electrical Characteristics @ T _{case} = 25 °C				
Symbol	Rating	Value		Unit
		min.	max.	
I _{sup}	Driver supply current quiescent; V _{sup} = 15 V operating	–	19	mA
I _i	Input signal current	–	1	µA

Switching times (see Fig. 62)

Module	Rating	Test conditions			Typical switching times			
	V _{DS} V	V _{DD} V	I _D A	t _{don} ns	t _r ns	t _{doff} µs	t _r ns	
SKM 111 ARC	100	50	130	280	500	1,5	600	
SKM 121 ARC	200	100	80	280	220	1,8	450	
SKM 141 C	400	200	60	250	120	2	450	
SKM 151 C	500	250	36	250	120	2	450	
SKM 151 FC	500	250	36	350	160	2	400	
SKM 181 C	800	400	23	350	130	2,3	400	
SKM 181 FC	800	400	23	330	120	2,5	430	
SKM 191 C	1000	500	17	350	150	2,5	450	
SKM 191 FC	1000	500	18	350	150	2,5	450	

SEMITRANS® M
Single Switch Power MOSFET Modules with Built-in Driver Circuit
SKM 111 ARC³⁾ SKM 181 C
SKM 121 ARC³⁾ SKM 181 FC
SKM 141 C SKM 191 C
SKM 151 C SKM 191 FC
SKM 151 FC

T-39-15

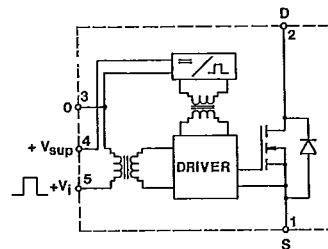
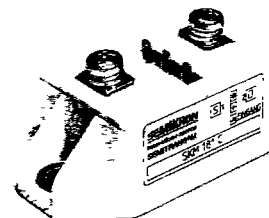

Features

- Internal isolation between input and output stages
- The power supply for the driver must not be isolated
- CMOS compatible input

Typical Applications

- DC choppers
- AC motor drives
- Power supplies for LASERs
- Uninterruptible power supplies
- Ultrasonic generator
- Plasma cutting
- Inductive heating
- Electronic welding

This is an electrostatic discharge sensitive device (ESDS). Please observe the international standard IEC 747-1, Chapter IX.

1) For the ratings and characteristics of the power MOSFET output stages see the corresponding tables and diagrams

2) The case temperature of the module is the ambient temperature of the built-in driver

3) These types contain gate resistors to reduce di/dt

4) For higher operating frequencies please consult your SEMIKRON service office

5) Important! See also the technical explanations in Part A

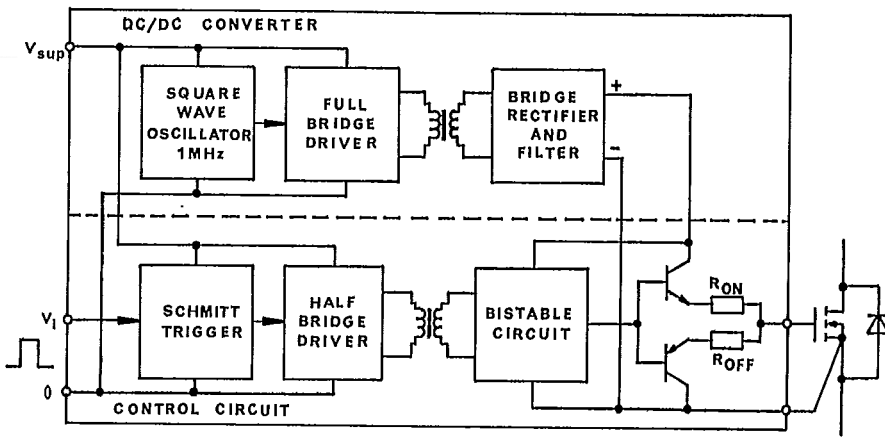

Fig. 61 Block diagram of the driver circuit

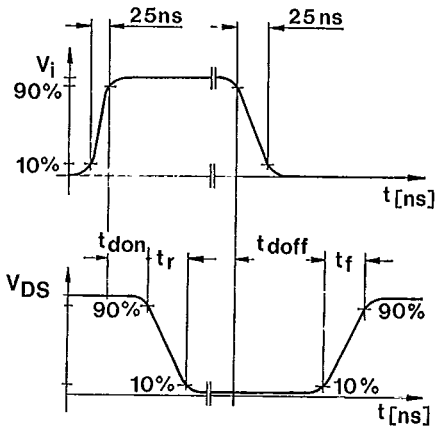

Fig. 62 Definitions of the switching times

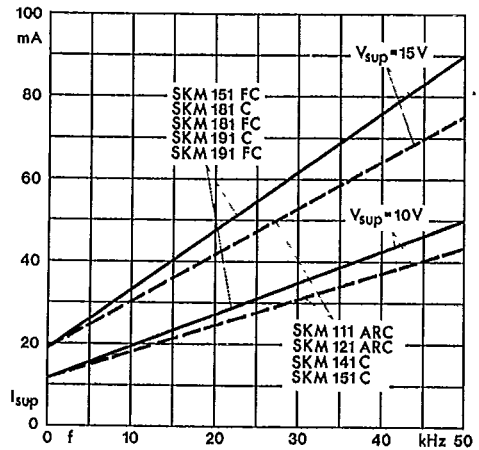

Fig. 63 Supply current vs. operating frequency

