

FEATURES AND SPECIFICATIONS

Features and Benefits

- Accommodate from 2 to 6 pods
- PCB retention clips hold shroud in place during soldering
- Fully customized
- Easy to assemble (no tools required)

Reference Information

Product Specification: PS-43510-00

Packaging Type: Tray

UL File No.: E29179

CSA File No.: LR19980

Mates With: [43838](#)Use With: [43952](#), [43954](#), [44032](#) Vertical Header Pods

Designed In: Millimeters

Mechanical

Pod Insertion Force: 5kg max.

Pod Retention to Housing: 10kg min.

Insertion force to PCB: 2.0kg max.

Physical

Housing: Glass-filled nylon, UL 94V-0

Operating Temperature: -40 to +105°C

PCB Thickness: 1.57, 2.36 or 3.18mm (.062, .093 or .125")

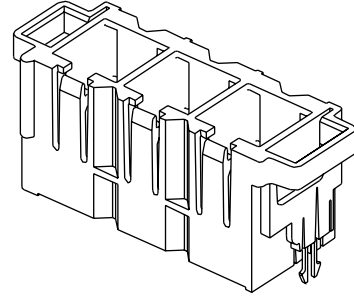
COMPODRE™
Wire-to-Board Header
44040**Header Shrouds**
Vertical

CATALOG DRAWING (FOR REFERENCE ONLY)

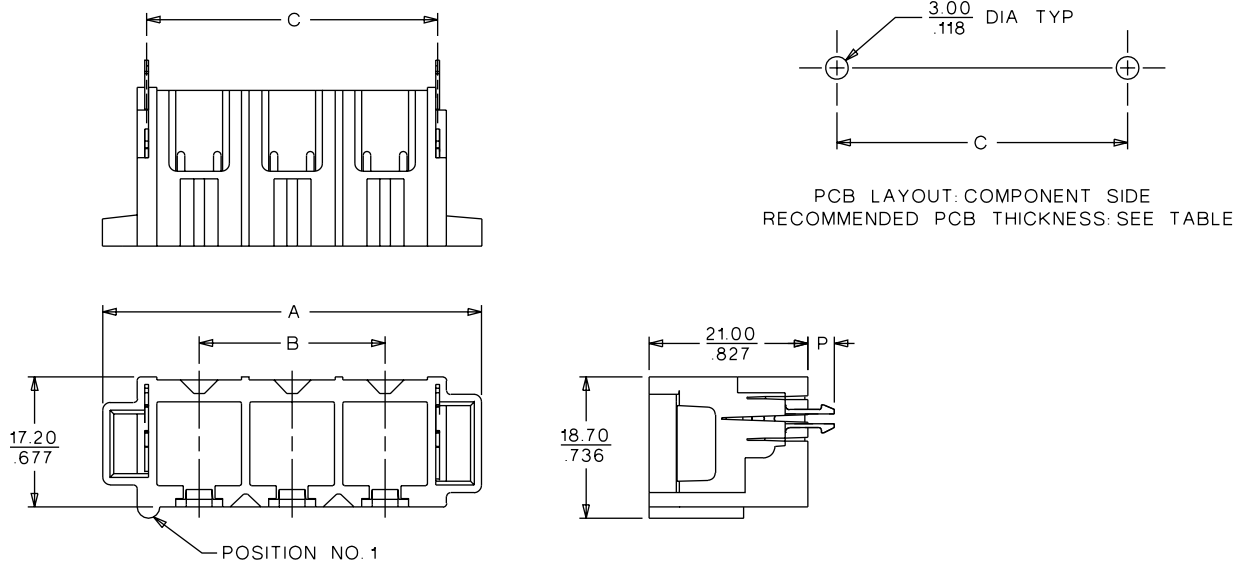

ORDERING INFORMATION AND DIMENSIONS

Description	Order No.	PCB Thickness	Dimensions			
			A	B	C	P
2 Position Vertical Header Shroud	44040-0001	1.57 (.062)	37.80 (1.488)	12.30 (.484)	26.16 (1.030)	3.55 (.140)
3 Position Vertical Header Shroud	44040-0002	1.57 (.062)	50.10 (1.972)	24.60 (.969)	38.46 (1.514)	3.55 (.140)
4 Position Vertical Header Shroud	44040-0003	1.57 (.062)	62.40 (2.457)	36.90 (1.453)	50.76 (1.998)	3.55 (.140)
5 Position Vertical Header Shroud	44040-0004	1.57 (.062)	74.70 (2.941)	49.20 (1.937)	63.06 (2.483)	3.55 (.140)
6 Position Vertical Header Shroud	44040-0005	1.57 (.062)	87.00 (3.425)	61.50 (2.421)	75.36 (2.967)	3.55 (.140)
2 Position Vertical Header Shroud	44040-0006	2.36 (.093)	37.80 (1.488)	12.30 (.484)	26.16 (1.030)	4.35 (.171)
3 Position Vertical Header Shroud	44040-0007	2.36 (.093)	50.10 (1.972)	24.60 (.969)	38.46 (1.514)	4.35 (.171)
4 Position Vertical Header Shroud	44040-0008	2.36 (.093)	62.40 (2.457)	36.90 (1.453)	50.76 (1.998)	4.35 (.171)
5 Position Vertical Header Shroud	44040-0009	2.36 (.093)	74.70 (2.941)	49.20 (1.937)	63.06 (2.483)	4.35 (.171)
6 Position Vertical Header Shroud	44040-0010	2.36 (.093)	87.00 (3.425)	61.50 (2.421)	75.36 (2.967)	4.35 (.171)
2 Position Vertical Header Shroud	44040-0011	3.18 (.125)	37.80 (1.488)	12.30 (.484)	26.16 (1.030)	5.15 (.203)
3 Position Vertical Header Shroud	44040-0012	3.18 (.125)	50.10 (1.972)	24.60 (.969)	38.46 (1.514)	5.15 (.203)
4 Position Vertical Header Shroud	44040-0013	3.18 (.125)	62.40 (2.457)	36.90 (1.453)	50.76 (1.998)	5.15 (.203)
5 Position Vertical Header Shroud	44040-0014	3.18 (.125)	74.70 (2.941)	49.20 (1.937)	63.06 (2.483)	5.15 (.203)
6 Position Vertical Header Shroud	44040-0015	3.18 (.125)	87.00 (3.425)	61.50 (2.421)	75.36 (2.967)	5.15 (.203)

MATERIAL NO.	MODULE QTY.	P.C. BOARD THICKNESS	DIM. "A"	DIM. "B"	DIM. "C"
44040-0001	2	1.57±.20 (.062±.008)	37.80/(1.488)	26.16/(1.030)	1.80/(.071)
44040-0002	3		50.10/(1.974)	38.46/(1.514)	
44040-0003	4		62.40/(2.457)	50.76/(1.998)	
44040-0004	5		74.70/(2.941)	63.06/(2.483)	
44040-0005	6	87.00/(3.425)	75.36/(2.967)		
44040-0006	2	2.36±.20 (.093±.008)	37.80/(1.488)	26.16/(1.030)	2.60/(.102)
44040-0007	3		50.10/(1.974)	38.46/(1.514)	
44040-0008	4		62.40/(2.457)	50.76/(1.998)	
44040-0009	5		74.70/(2.941)	63.06/(2.483)	
44040-0010	6	87.00/(3.425)	75.36/(2.967)		
44040-0011	2	3.18±.20 (.125±.008)	37.80/(1.488)	26.16/(1.030)	3.40/(.134)
44040-0012	3		50.10/(1.974)	38.46/(1.514)	
44040-0013	4		62.40/(2.457)	50.76/(1.998)	
44040-0014	5		74.70/(2.941)	63.06/(2.483)	
44040-0015	6	87.00/(3.425)	75.36/(2.967)		

NOTES:

- MATERIAL; HOUSING: NYLON, GLASS FILLED, UL 94V-0. COLOR: BLACK
MOUNTING CLIP: BRASS
- FINISH: NONE
- PRODUCT SPEC.: PS-435 IO-002.
- ALL DIMENSIONS ARE REFERENCE ONLY EXCEPT P.C. BOARD LAYOUT DIMENSIONS.
- PARTS ARE NOT TO BE MATED OR UNMATED WHILE CIRCUITS ARE LIVE.
- RIB INDICATES POD NO. LOCATION.
- PART MATES WITH 43838-0*** RECEPTACLE SHROUD.
- POD SHOWN LOADED INTO SHROUD FOR REFERENCE ONLY.
- THIS PART IS DESIGNED TO ACCEPT VERTICAL HEADER POD ASSEMBLIES AND BLIND MATE PODS.

APPLICATION NOTES:

- PLACE THE HIGH CURRENT MINI-FIT SR, PODS IN THE OUTER POSITIONS OF THE SHROUD TO MAXIMIZE CURRENT CARRYING CAPABILITY.
- IF MORE THAN ONE MINI-FIT SR, POD IS USED, PLACE THEM AS FAR APART AS POSSIBLE IN THE SHROUD TO MAXIMIZE CURRENT CARRYING CAPABILITY.
- REFER TO THE INDIVIDUAL PRODUCT'S PRODUCT SPECIFICATION FOR DETAILED PERFORMANCE CHARACTERISTICS OF EACH. (MINI-FIT JR., MINI-FIT SR., MICRO-FIT 3.0, ETC.)
- THE SHROUD PROVIDES SYSTEM POLARIZATION, PODS MUST NEVER BE APPLIED WITHOUT THE USE OF THE SHROUD, 'MALE' AND 'FEMALE' PODS CAN BE INSERTED INTO EITHER SHROUD FOR ADDITIONAL CONNECTOR POLARIZATION, WHEN MULTIPLE COMPODE SYSTEMS ARE USED IN A SINGLE APPLICATION, THE PODS MAY BE POSITIONED TO PROVIDE FOOLPROOF HARNESS TO HEADER POLARIZATION.
- FOR PROPER MATING OF SHROUDS, THE POD LOCKING FINGERS ON BOTH SHROUDS MUST BE ORIENTED SUCH THAT THEY ARE ON THE SAME PLANE WHEN MATING THE CONNECTORS. THE SIDE LATCHES OF THE SHROUD ARE DESIGNED TO PROVIDE POLARIZATION.
- EACH SHROUD POD BAY IS KEYS TO PROVIDE POLARIZATION, THE POD MUST BE INSTALLED IN THE DIRECTION SHOWN, WHEN INSERTING A POD INTO THE SHROUD, THE "U" SHAPED FEATURE ON THE SIDE OF THE POD MUST BE ORIENTED TO THE SAME FACE AS THE POD LOCKING FINGERS ON THE SHROUD.
- AS THE "FACE TO FACE" MATING OF THE PODS IS CRITICAL TO ASSURE THAT ALL CONTACTS ARE FULLY "WIPE", THE TOLERANCES OF THE SHROUD TO SHROUD MATING ARE TIGHTLY CONTROLLED, THEREFORE, WHEN SEATING A POD INTO A SHROUD, MAKE CERTAIN THAT THE SHROUD LOCKING FINGER IS FULLY SEATED INTO THE POD, IT MAY BE NECESSARY AT TIMES TO APPLY A SLIGHT VERTICAL FORCE TO THE LOCKING FINGER TO SEAT THE POD FULLY, ALSO, WHEN MATING TWO SHROUDS, ASSURE THAT THE SHROUD POSITIVE LOCKS, LOCATED ON THE SIDES OF THE SHROUD, ARE FULLY ENGAGED WITH THE MATING SHROUD.
- PODS MAY BE REMOVED FROM SHROUDS IF REQUIRED, TO REMOVE A POD, SIMPLY DEFLECT THE LOCKING FINGER AWAY FROM THE POD, USING A FINGER NAIL OR A SMALL STRAIGHT BLADE SCREWDRIVER, JUST FAR ENOUGH TO DISENGAGE THE POD. CAUTION: EXCESSIVE DEFLECTION MAY DAMAGE OR DESTROY THE LOCKING FINGER.
- THE SHROUD PROVIDES SYSTEM POLARIZATION, PODS MUST NEVER BE APPLIED WITHOUT THE USE OF A SHROUD.
- MATED CONNECTOR ASSEMBLIES MUST BE UNMATED WITH A STRAIGHT PULL IN THE DIRECTION SHOWN, TO PREVENT DAMAGE, AVOID ROTATING ASSEMBLY DURING UNMATING.

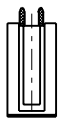

INSERT PODS IN THIS DIRECTION UNTIL FULLY LATCHED IN SHROUD, SEE APPLICATION NOTES 6 AND 7
PODS ARE KEYS TO PREVENT IMPROPER ASSEMBLY.

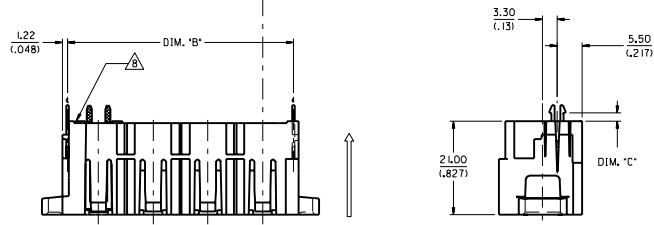

SEE APPLICATION NOTE 10

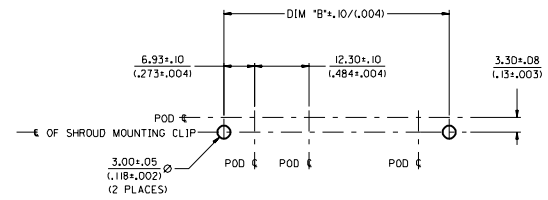
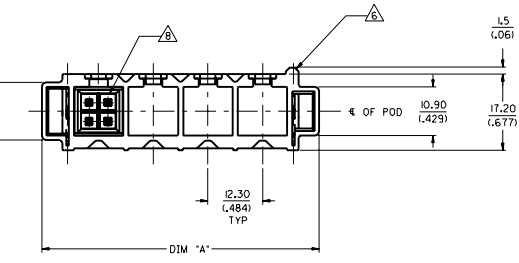

RECOMMENDED P.C. BOARD LAYOUT COMPONENT SIDE

43516-0001	BLIND-MATE POD
44032-0+01	6 CIRCUIT MICRO-FIT VERTICAL HEADER
43954-0+01	4 CIRCUIT MINI-FIT JR. VERTICAL HEADER
43952-0+01	1 CIRCUIT MINI-FIT SR. VERTICAL HEADER
MATERIAL NO.	DESCRIPTION

AVAILABLE PODS

REV. DKT. # I I.D. RIB	QUALITY SYMBOLS	GENERAL TOLERANCES: (UNLESS SPECIFIED)	SCALE 2:1	DESIGN UNITS mm INCH	DIMENSIONS: mm INCH	SHT REV	
EC NO. UCR 899-0744	MAJOR		DRAWN BY & DATE			REVISE ON CAD ONLY	
DRW/POL CAR 9900400	CRITICAL		POL CAR 98/01/23				
DRW/COMERC 9900400			CHECKED BY & DATE				
APPL/COMERC 9900400			COMERC I 98/01/28				
			APPROVED BY & DATE				
			COMERC I 98/01/28				
			ANGULAR: ± 1/2°				
			CAD FILENAME	MATERIAL NO.	DRAWING NO.	SHEET NO.	
			S4404001.DGN		SD-44040-001	1 OF 1	
			DRAFT WHERE APPLICABLE MUST REMAIN WITHIN DIMENSIONS				SIZE D
			THIS DRAWING CONTAINS INFORMATION THAT IS PROPRIETARY TO MOLEX INCORPORATED AND SHOULD NOT BE USED WITHOUT WRITTEN PERMISSION.				