

300mA Low Dropout Linear Regulator with Shutdown

■ Features

- Input voltage range is up to 7V
- Dropout voltage 400mV at 300mA output current
- Guaranteed 300mA output current.
- Internal $R_{on} = 1.5\Omega$ PMOS draws no base current
- Low quiescent current 50 μ A
- Output voltage: 1.5V/1.8V/2.0V/2.5V/2.8V/3.0V/3.3V/3.5V; accuracy 2%
- Active low shutdown function (EN pin).
- Fast transient response
- Good load regulation
- Current limit and thermal shutdown protection
- Short circuit current fold-back
- SOT89-5L, SOT23-5L and TSOT23-5L **Pb-Free** Package

■ Applications

- Wireless Communication
- Battery Powered device
- CD-ROM, DVD, and LAN Card
- PC peripheral

■ Pin Assignments

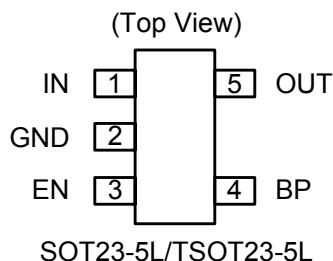
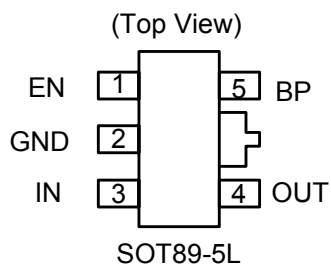

■ General Descriptions

The AP131 is a 300mA, fixed output voltage, low dropout linear regulator. The Device included pass element, error amplifier, band-gap, current limit and thermal shutdown circuitry. The device is ON when EN pin is set to logic high level.

The characteristics of low dropout voltage and less quiescent current make it good for some critical application, for example, some battery powered devices. The typical quiescent current is approximately 50 μ A from zero to maximum load. Due to internal flexible design, result in extensively fixed output voltage versions and make it convenient to use for applications. Built-in current-limit and thermal-shutdown functions prevent any fault condition from IC damage. An external capacitor can be connected to the BP pin and reduce the output noise.

■ Pin Descriptions

Name	Description
IN	Input voltage
GND	Ground
EN	Enable pin
BP	Bandgap
OUT	Output voltage

300mA Low Dropout Linear Regulator with Shutdown

■ Ordering Information

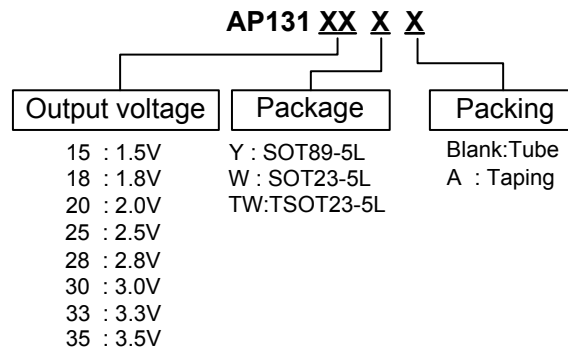

■ Block Diagram

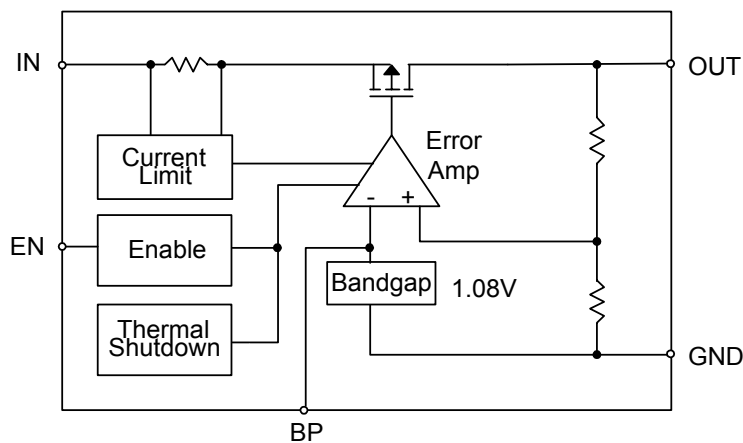

■ Absolute Maximum Ratings

Symbol	Parameter	Rating	Unit
V_{CC}	Input Voltage	-0.1 to +7	V
T_{OP}	Operating Junction Temperature Range	-40 to +125	°C
T_{ST}	Storage Temperature Range	-65 to +150	°C
P_D	Power Dissipation, P_D @ $T_A=25^\circ\text{C}$		
	SOT89-5L	+0.5	W
	SOT23-5L / TSOT23-5L	+0.25	W
θ_{JA}	Package Thermal Resistance		
	SOT89-5L	+100	°C/W
	SOT23-5L / TSOT23-5L	+250	°C/W

300mA Low Dropout Linear Regulator with Shutdown

■ Electrical Characteristics

$T_A=25^{\circ}\text{C}$, $C_{IN}=1\mu\text{F}$, $C_{OUT}=10\mu\text{F}$, unless otherwise specified.

Symbol	Parameter	Conditions	Min.	Typ.	Max.	Unit
V_{DROP}	Dropout Voltage (Note 1)	$I_L=300\text{mA}$	-	400	500	mV
I_{LIMIT}	Current Limit (Note 2)	$V_{\text{IN}}=5\text{V}$, $V_{\text{OUT}}=0\text{V}$	350	450	-	mA
I_{short}	Short Circuit Current	$V_{\text{OUT}}<1.05\text{V}$	-	150	300	mA
ΔV_{LINE}	Line Regulation	$I_L=1\text{mA}$, $V_{\text{IN}}=5\sim 7\text{V}$	-	0.1	0.3	%/V
ΔV_{LOAD}	Load Regulation (Note 3)	$I_L=1\sim 300\text{mA}$, $V_{\text{IN}}=5\text{V}$	-	30	35	mV
ΔV_{OUT}	Output Voltage Accuracy	$I_L=1\text{mA}$, $V_{\text{IN}}=5\text{V}$	-2	-	+2	%
	Output Voltage Temperature Coefficient (Note 4)		-	50	150	PPM/ $^{\circ}\text{C}$
PSRR	Ripple Rejection	$F=100\text{Hz}$, $C_{\text{IN}}=1\mu\text{F}$, $C_{\text{O}}=10\mu\text{F}$, $I_L=100\text{mA}$	-	60	-	dB
I_{SB}	Standby Current	$I_L=0\text{mA}$, $V_{\text{IN}}=5\text{V}$, $\text{EN}=0\text{V}$	-	-	5	μA
I_{Q}	Quiescent Current	$I_L=0\text{mA}$, $V_{\text{IN}}=5\text{V}$, $\text{EN}=5\text{V}$	-	50	100	μA
I_{EN}	Enable Pin Current		-	-	< 0.1	μA
V_{ENON}	Enable Pin Voltage	Output ON	1.5	-	V_{IN}	V
V_{ENOFF}		Output OFF	0	-	0.8	V
T_{DELAY}	Enable Delay Time	$C_{\text{BP}}=0.1\mu\text{F}$, $C_{\text{OUT}}=1\mu\text{F}$, $I_{\text{OUT}}=30\text{mA}$	-	8	-	μS

Note 1. Dropout voltage is defined as the input to output differential voltage. Dropout is measured at constant junction temperature by using pulsed ON time, and the criterion is V_{OUT} inside target value $\pm 2\%$. This test is skipped at the condition of $V_{\text{IN}}<3\text{V}$.

Note 2. Current limit is measured at constant junction temperature by using pulsed testing with a low ON time.

Note 3. Regulation is measured at constant junction temperature by using pulsed testing with a low ON time.

Note 4. Guaranteed by design.

■ Typical Application Circuit

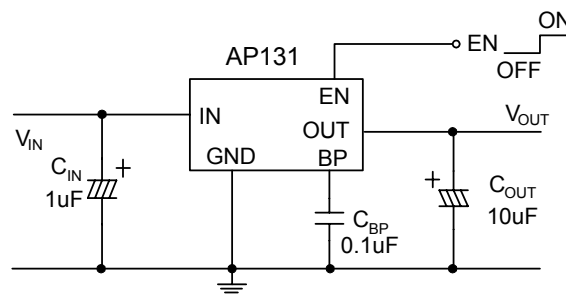

■ Typical Characteristics

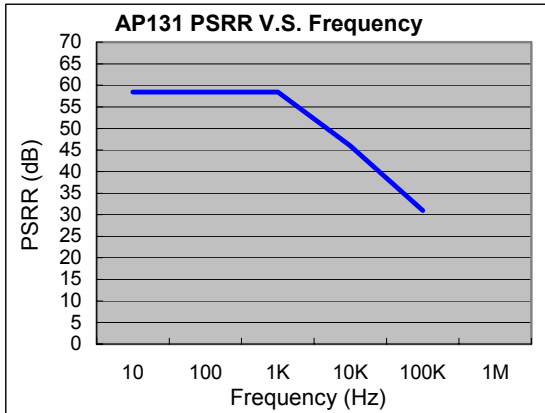

PSRR V.S. Frequency

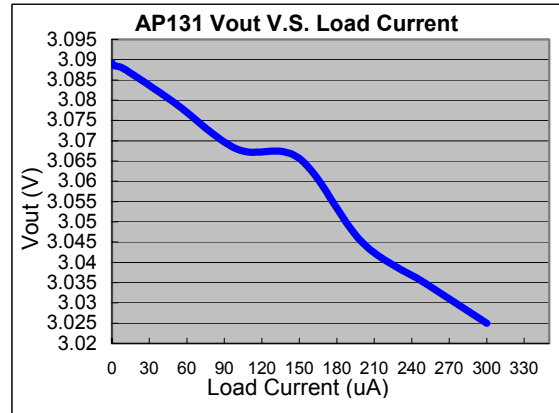

Vout V.S. Load Current

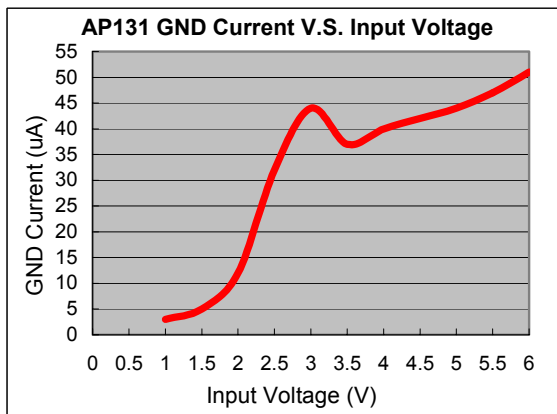

GND Current V.S. Input Voltage

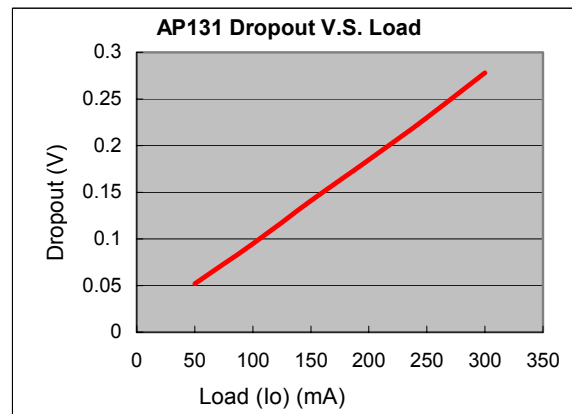

Dropout V.S. Load

■ Marking Information

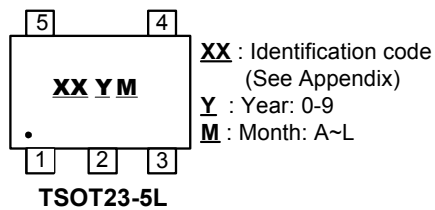
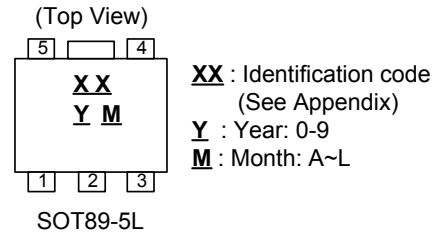
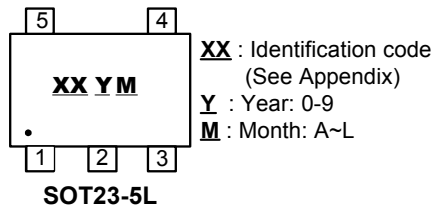

Appendix

Part Number		Identification code
SOT23-5/TSOT23-5	SOT89-5	
AP131-15W	AP131-15Y	DA
AP131-18W	AP131-18Y	DD
AP131-20W	AP131-20Y	DF
AP131-25W	AP131-25Y	DK
AP131-28W	AP131-28Y	DN
AP131-30W	AP131-30Y	DP
AP131-33W	AP131-33Y	DS
AP131-35W	AP131-35Y	DU

■ Package Information

(1) Package Type: SOT89-5L

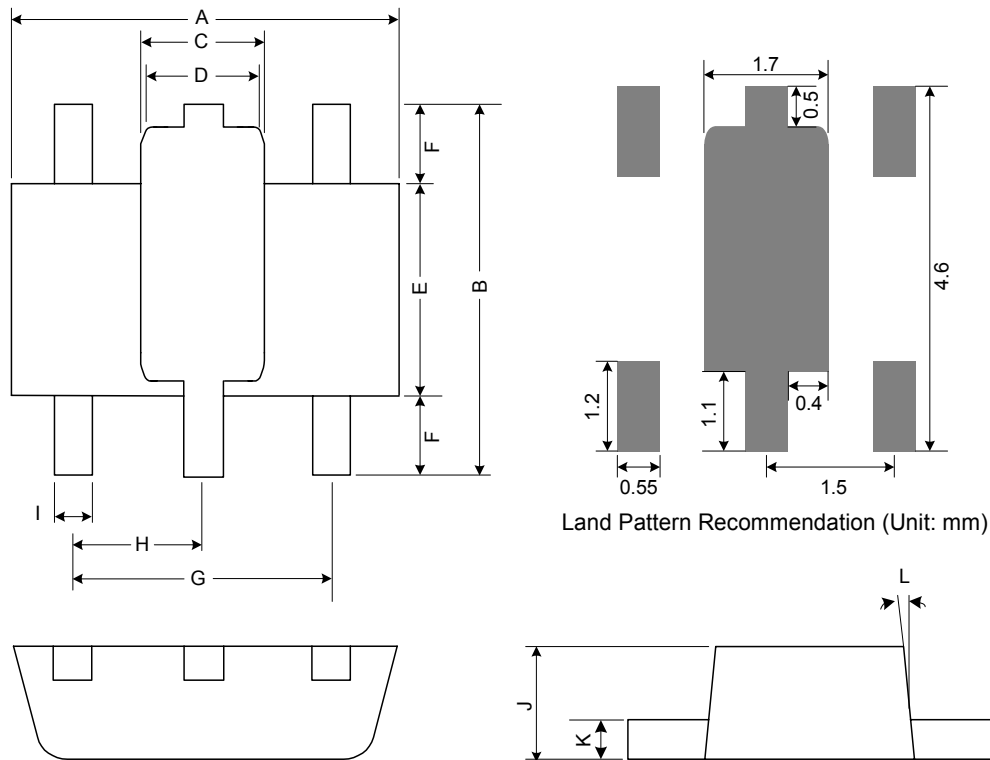

Symbol	Dimensions In Millimeters			Dimensions In Inches		
	Min.	Nom.	Max.	Min.	Nom.	Max.
A	4.40	4.50	4.60	0.173	0.177	0.181
B	4.05	4.15	4.25	0.159	0.163	0.167
C	1.50	1.60	1.70	0.059	0.063	0.067
D	1.30	1.40	1.50	0.051	0.055	0.059
E	2.40	2.50	2.60	0.094	0.098	0.102
F	0.80	-	-	0.031	-	-
G	3.00 Ref.			0.118 Ref.		
H	1.50 Ref.			0.059 Ref.		
I	0.40	0.46	0.52	0.016	0.018	0.020
J	1.40	1.50	1.60	0.055	0.059	0.063
K	0.35	0.39	0.43	0.014	0.015	0.017
L	5° Typ.			5° Typ.		

■ Package Information (Continued)

(2) Package Type: SOT23-5L

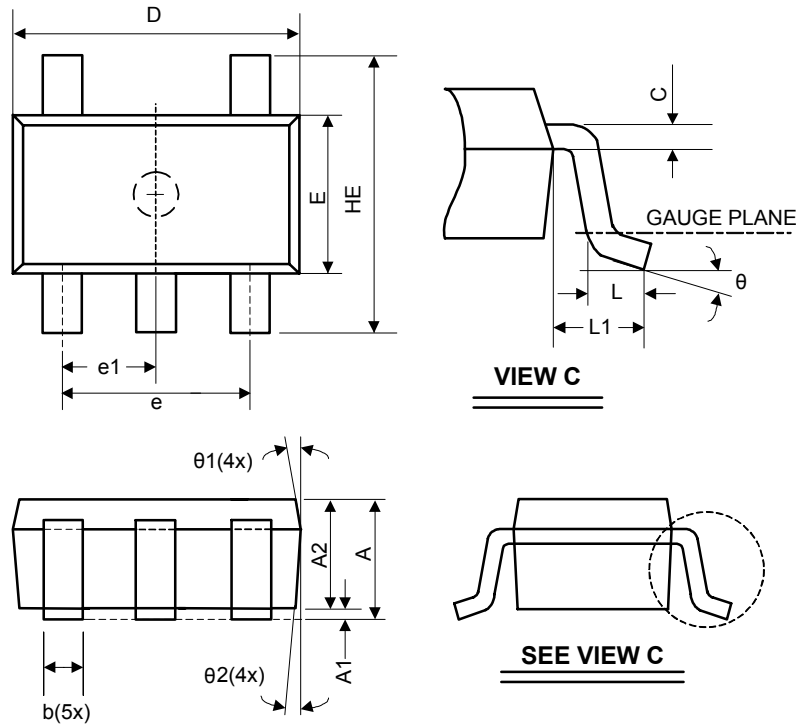

Symbol	Dimensions In Millimeters			Dimensions In Inches		
	Min.	Nom.	Max.	Min.	Nom.	Max.
A	1.05	-	1.35	0.041	-	0.053
A1	0.05	-	0.15	0.002	-	0.006
A2	1.00	1.10	1.20	0.039	0.043	0.047
b	0.25	-	0.50	0.010	-	0.020
C	0.08	-	0.20	0.003	-	0.008
D	2.70	2.90	3.00	0.106	0.114	0.118
E	1.50	1.60	1.70	0.059	0.063	0.067
HE	2.60	2.80	3.00	0.102	0.110	0.118
L	0.30	-	0.60	0.012	-	0.024
L1	0.50	0.60	0.70	0.020	0.024	0.028
e	1.80	1.90	2.00	0.071	0.075	0.079
e1	0.85	0.95	1.05	0.033	0.037	0.041
theta	0°	5°	10°	0°	5°	10°
theta1	3°	5°	7°	3°	5°	7°
theta2	6°	8°	10°	6°	8°	10°

300mA Low Dropout Linear Regulator with Shutdown

■ Package Information (Continued)

(3) Package Type: TSOT23-5L

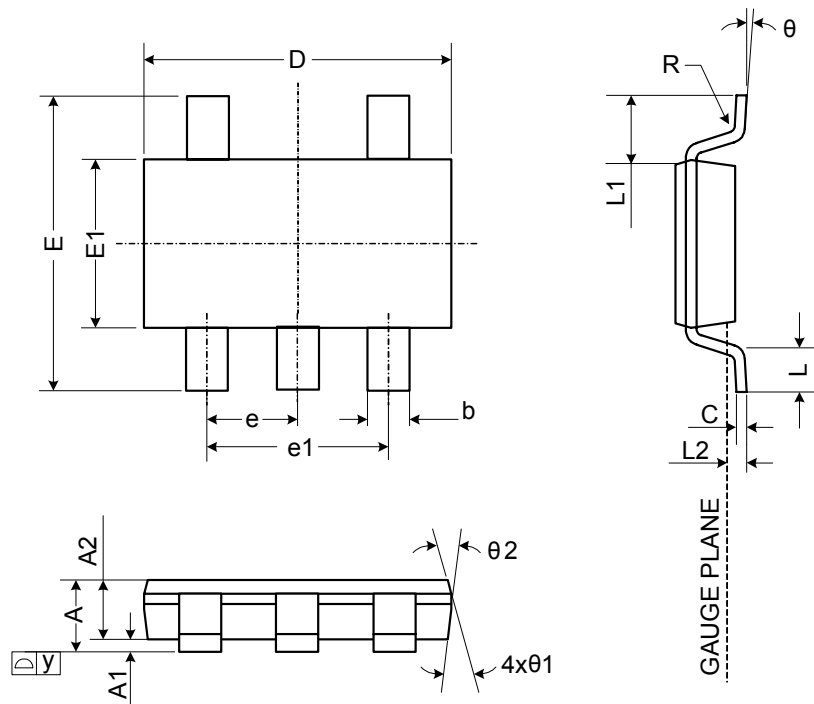

Symbol	Dimensions In Millimeters			Dimensions In Inches		
	Min.	Nom.	Max.	Min.	Nom.	Max.
A	0.75	-	0.90	0.030	-	0.035
A1	0.00	-	0.10	0.000	-	0.004
A2	0.70	0.75	0.80	0.028	0.030	0.031
b	0.35	-	0.51	0.014	-	0.020
C	0.10	-	0.25	0.004	-	0.010
D	2.80	2.90	3.00	0.110	0.114	0.118
E	2.60	2.80	3.00	0.102	0.110	0.118
E1	1.50	1.60	1.70	0.059	0.063	0.067
e	0.95 BSC.			0.037		
e1	1.90 BSC.			0.075		
L	0.37	-	-	0.015	-	-
L1	0.60 REF.			0.024		
L2	0.25 BSC.			0.010		
y	-	-	0.10	-	-	0.004
R	0.10	-	-	0.004	-	-
θ	0°	-	8°	0°	-	8°
θ1	7° NOM.			7° NOM.		
θ2	5° NOM.			5° NOM.		