

### Description

- 125°C maximum temperature operation
- Low profile surface mount inductor
- 8.3mm x 9.5mm x 3.0mm shielded drum core
- Ferrite core material
- Inductance range from 2.7µH to 100µH
- Current range from 6.6 Amps to 0.8 Amps
- Frequency range up to 1MHz

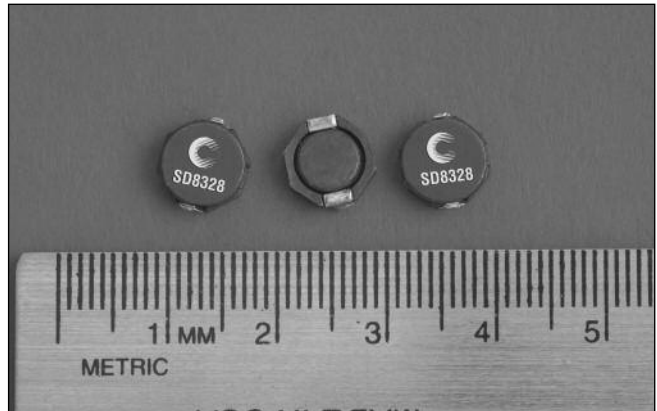

### Applications

- Buck or Boost inductor
- Noise filtering output filter chokes
- Notebook power/display
- LCD Monitors/Displays/Televisions
- Battery chargers, LCD bias supplies
- Battery and Industrial power systems
- Computer, DVD players
- Portable power devices, DC-DC converters

### Environmental Data

- Storage temperature range: -40°C to +125°C
- Operating temperature range: -40°C to +125°C (range is application specific)
- Solder reflow temperature: +260°C max. for 10 seconds maximum

### Packaging

- Supplied in tape and reel packaging, 1280 per reel

Part Number	Rated Inductance (µH)	OCL (1) µH±30%	Irms(2) Amperes	Isat (3) Amperes	DCR (Ω) mΩ @20°C (Typical)	DCR (Ω) mΩ @20°C (Maximum)	K-factor (4)
SD8328-2R5-R	2.5	2.7	6.6	4.5	12	15.6	43
SD8328-3R3-R	3.3	3.4	6.1	4.0	14	18.0	33
SD8328-4R7-R	4.7	5.0	4.5	3.6	19	24.7	23
SD8328-7R3-R	7.3	7.6	3.4	2.9	30	39	15
SD8328-100-R	10	9.1	3.3	2.6	36	45	11
SD8328-150-R	15	14.5	2.35	2.0	53	69	7.2
SD8328-220-R	22	21.1	1.85	1.7	76	99	4.9
SD8328-330-R	33	31.9	1.45	1.4	120	156	3.3
SD8328-470-R	47	44.9	1.30	1.2	150	194	2.3
SD8328-680-R	68	64.2	0.98	1.0	220	286	1.6
SD8328-101-R	100	97.0	0.80	0.8	330	430	1.1

- (1) Open Circuit Inductance Test Parameters: 100kHz, 0.1V, 0.0Adc.  
 (2) I<sub>rms</sub>: DC current for an approximate ΔT of 40°C without core loss. Derating is necessary for AC currents. PCB layout, trace thickness and width, air-flow, and proximity of other heat generating components will affect the temperature rise. It is recommended that the temperature of the part not exceed 125°C under worst case operating conditions verified in the end application.  
 (3) I<sub>sat</sub> Amperes peak for approximately 35% rolloff (@25°C)

- (4) K-factor: Used to determine B p-p for core loss (see graph).  
 B p-p = K\*L\*ΔI, B p-p(mT), K: (K factor from table), L: (Inductance in µH), ΔI (Peak to peak ripple current in Amps).  
 (5) Part Number Definition: SD8328-xxx-R  
 SD8328 = Product code and size; -xxx = Inductance value in uH;  
 R = decimal point; If no R is present, third character = # of zeros.  
 -R suffix = RoHS compliant

### Mechanical Diagrams

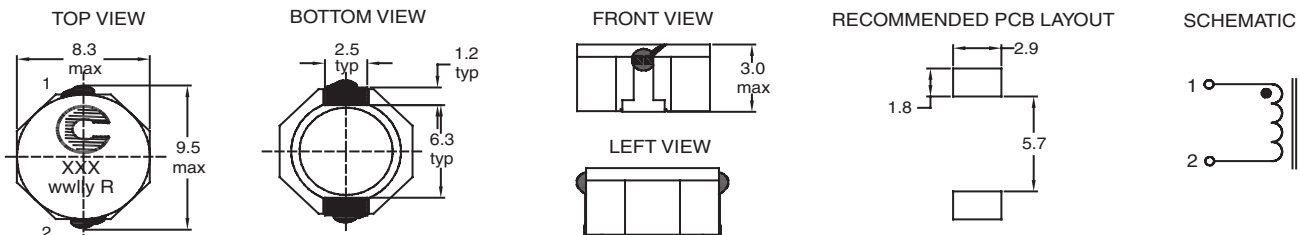

Dimensions are in millimeters.

xxx = Inductance value in uH. R = decimal point. If no R is present third character = # of zeros. wwlyy = Date code, R = Revision level.

## Packaging Information

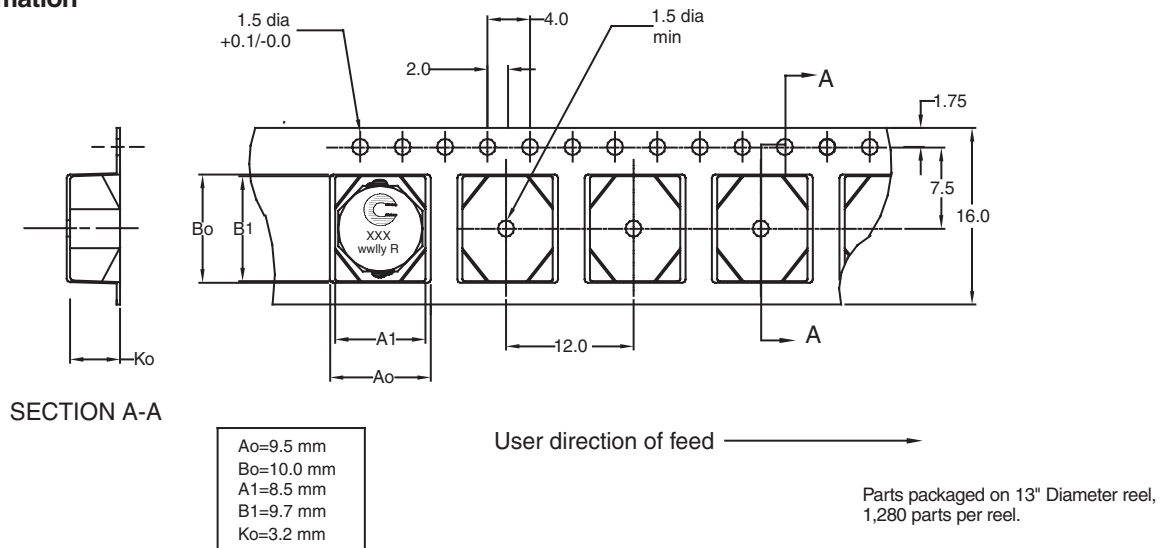

## Core Loss

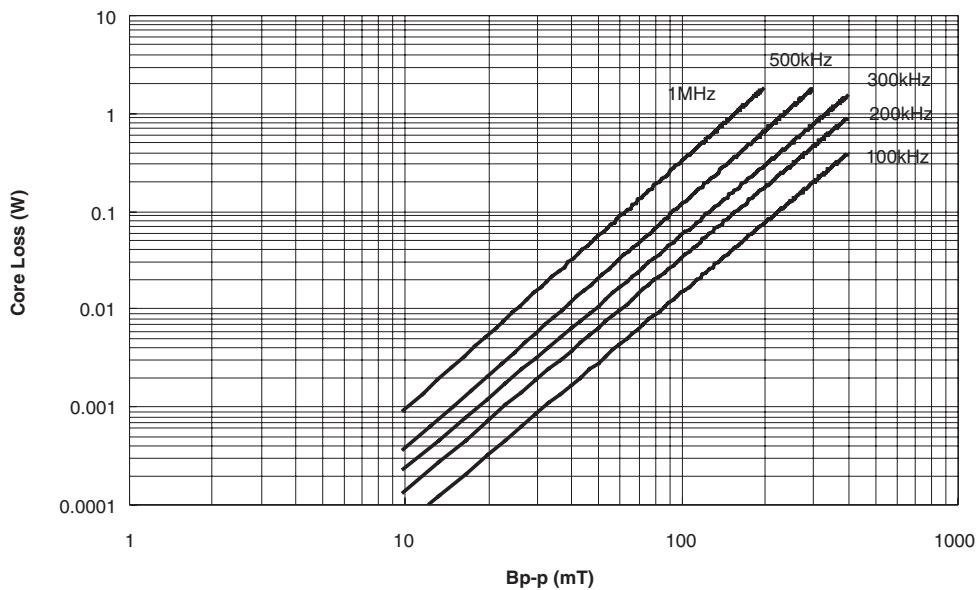

Temperature Rise vs. Loss

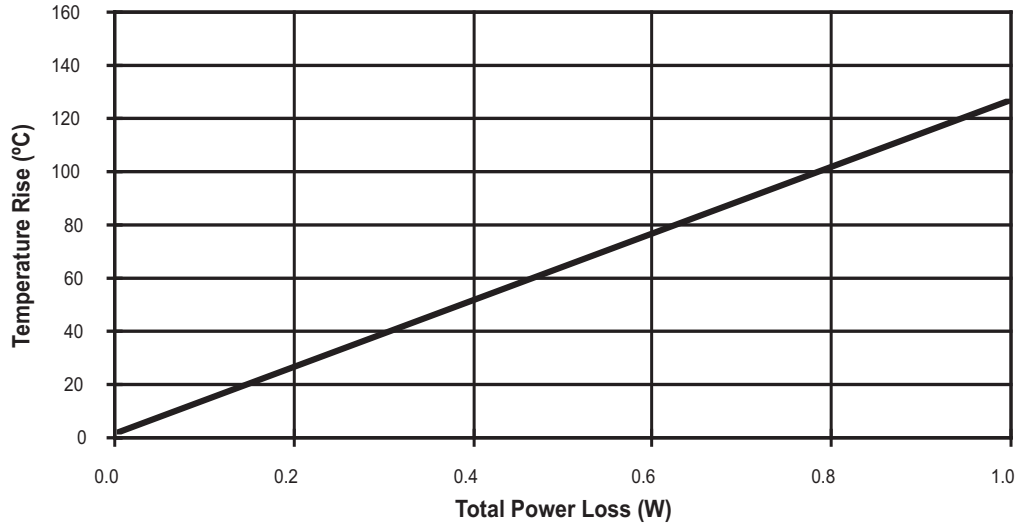

Inductance Characteristics

OCL Vs. Isat

