



UA6K

DUAL TRANSISTOR

GENERAL PURPOSE (DUAL DIGITAL TRANSISTOR)

FEATURES

- * Two DTA144T chips in a SOT-363 package.
- * Mounting cost and area can be cut in half.

EQUIVALENT CIRCUIT

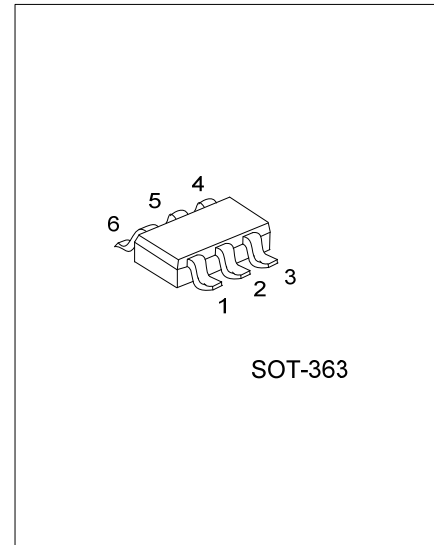
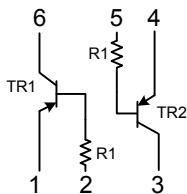

SOT-363

*Pb-free plating product number: UA6KL

ORDERING INFORMATION

Ordering Number		Package	Pin Assignment						Packing
Normal	Lead Free Plating		1	2	3	4	5	6	
UA6K-AL6-R	UA6KL-AL6-R	SOT-363	E1	B1	C2	E2	B2	C1	Tape Reel

<p>UA6KL-AL6-R</p> <ul style="list-style-type: none"> (1) Packing Type (2) Package Type (3) Lead Plating 	<ul style="list-style-type: none"> (1) R: Tape Reel (2) AL6: SOT-363 (3) L: Lead Free Plating, Blank: Pb/Sn
---	--

MARKING

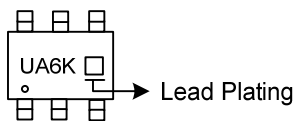

■ ABSOLUTE MAXIMUM RATINGS (T_A=25°C)

PARAMETER	SYMBOL	RATINGS	UNIT
Collector-Base Voltage	V _{CB0}	-50	V
Collector-Emitter Voltage	V _{CEO}	-50	V
Emitter-Base Voltage	V _{EBO}	-5	V
Collector Current	I _C	-100	mA
Collector Power dissipation	P _C	200	mW
Junction Temperature	T _J	150	°C
Storage Temperature	T _{STG}	-55~+150	°C

Note: Absolute maximum ratings are those values beyond which the device could be permanently damaged.

Absolute maximum ratings are stress ratings only and functional device operation is not implied.

■ ELECTRICAL CHARACTERISTICS (T_A=25°C, unless otherwise specified)

PARAMETER	SYMBOL	TEST CONDITIONS	MIN	TYP	MAX	UNIT
Collector-base breakdown voltage	BV _{CB0}	I _C = -50μA	-50			V
Collector-emitter breakdown voltage	BV _{CEO}	I _C = -1mA	-50			V
Emitter-base breakdown voltage	BV _{EBO}	I _E = -50μA	-5			V
Collector cutoff current	I _{CB0}	V _{CB} = -50V			-0.5	μA
Emitter cutoff current	I _{EBO}	V _{EB} = -4V			-0.5	μA
Collector-emitter saturation voltage	V _{CE(SAT)}	I _C = -5mA, I _B = -0.5mA			-0.3	V
DC current transfer ratio	h _{FE}	V _{CE} = -5V, I _C = -1mA	100	250	600	
Transition frequency	f _T	V _{CE} = -10V, I _E = 5mA, f = 100MHz (Note)		250		MHz
Input resistance	R ₁		32.9	47	61.1	kΩ

Note: Transition frequency of the device

■ TYPICAL CHARACTERISTICS

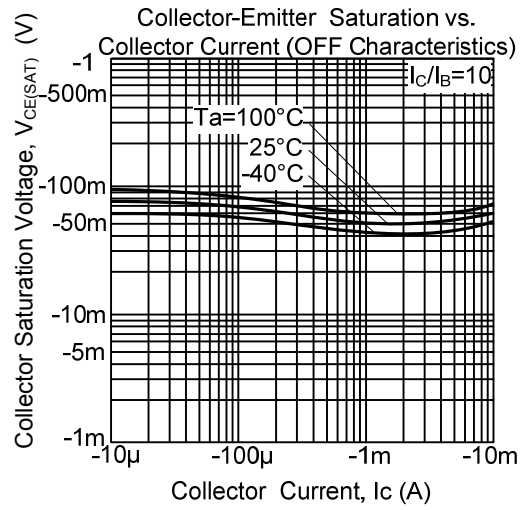
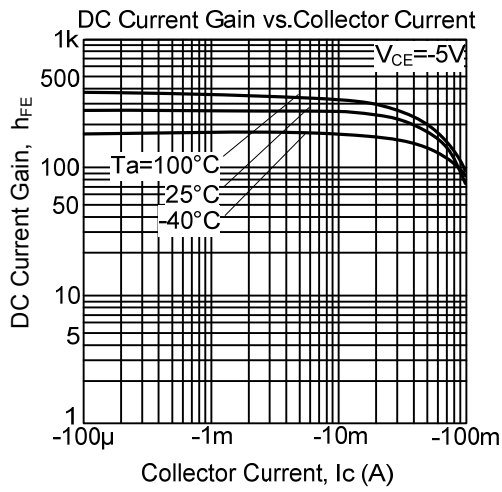

UTC assumes no responsibility for equipment failures that result from using products at values that exceed, even momentarily, rated values (such as maximum ratings, operating condition ranges, or other parameters) listed in products specifications of any and all UTC products described or contained herein. UTC products are not designed for use in life support appliances, devices or systems where malfunction of these products can be reasonably expected to result in personal injury. Reproduction in whole or in part is prohibited without the prior written consent of the copyright owner. The information presented in this document does not form part of any quotation or contract, is believed to be accurate and reliable and may be changed without notice.