

cPCI Series (2mm) Connectors

Interchangeable with cPCI COTS Systems

- Hi-Rel and Space Grade Versions
- Standard 2mm Footprint of cPCI PICMG 2.0
- Immune to Shock and Vibration
- LCP Insulator meets NASA Outgassing Requirements
- Compatible with IEC 1076-4 101
- Press-Fit Termination also available for Receptacle Assembly: Consult Factory
- NASA GSFC Qualified Part Numbers Available

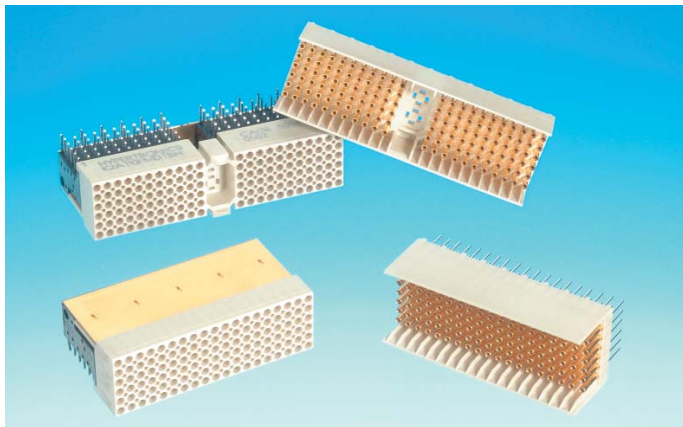

Subject to Export Control Procedure

Qualification Testing

The 2mm cPCI family of connectors meets MIL-DTL-55302, EEE-INST-002, GEVS-SE Rev. A, and NASA GSFC S-311-P-822 specifications.

Testing includes but is not limited to:

LLCR: Low Level Contact Resistance

DWV: Dielectric Withstanding Voltage

CRD: Contact Resistance

IR: Insulation Resistance

MFG: Mixed Flowing Gas

S & V: Shock and Vibration

General Specifications	QCI (Quality Conformance Inspections) K2 Series = MIL-DTL-55302 311P Series = NASA GSFC S-311-P-822					
3U / 6U Form Factor	P1 / P4	P2 / P5	P3	J1 / J4	J2 / J5	J3
Part Number Reference	K2A110FMD	K2B110FMD	K2B95FMD	K2A110FFD	K2B110FFD	K2B95FFD
Design Criteria	IEC 1076-4 101					
Contact Gender	Male Pin			Hypertac 0.40mm socket		
Contact Termination	Solder tail tin/lead (63/37) per MIL-P-81728					
Contact Spacing	2.00mm					
Number of Contacts	110 signal 22 ground		95 signal 19 ground	110 signal 22 ground		95 signal 19 ground
Contact Current Rating	1 Amp					
Temperature Range	-55° C to 125° C					
Insulator Material	30% Glass Filled LCP (meets NASA outgassing specification)					
Flammability Rating	94 V-O					
Insulation Resistance	> 5000 megohm					
Contact Material	Beryllium copper pin contacts			Beryllium copper Hypertac socket wires and brass body		
Mating Contact Plating	50µin gold / 50µin nickel					
Maximum Allowable Gap Between Mating Connectors	0.059 [1.50]					
Suggested Printed Circuit Board Hole Diameter	0.70mm after plating			0.60mm after plating		
Weight	0.55 oz.	0.53 oz.	0.38 oz.	0.38 oz.	0.45 oz.	0.31 oz.

Dimensions are in inches [mm]

Performance Specifications						
3U / 6U Form Factor	P1 / P4	P2 / P5	P3	J1 / J4	J2 / J5	J3
Part Number Reference	K2A110FMD	K2B110FMD	K2B95FMD	K2A110FFD	K2B110FFD	K2B95FFD
CRD (Resistance at Rated Current)	4.85 milliohms average					
LLCR (Low Level Contact Resistance)	7.20 milliohms average					
DWV (Dielectric Withstanding Voltage)	1000V RMS					
Contact Life (Mate / Demate)	> 4000 Cycles (per mated connector pair)					
Mating Force	16.38 LBF average (per mated connector pair)					
Demating Force	13.2 LBF average (per mated connector pair)					
Vibration (Sinusoidal)*	Frequency 10 to 2000 HZ at 15 G (MIL-DTL-55302)					
Vibration (Random)**	Flight chassis unit level vibration (NASA Goddard GEVS SE Rev A)					
Mechanical Shock*	100 G peak value (MIL-DTL-55302)					

* Testing was performed to determine if fretting occurs due to mechanical motion and to evaluate the integrity of the Hypertac contact system relative to severe shock. To validate the test, low nanosecond event detection was performed at 10 nanoseconds. **There were no events recorded.**

** Testing was performed using a 6U Flight Chassis to determine if fretting occurs due to mechanical motion and to evaluate the integrity of the test samples relative to severe mechanical environment. To validate the test, low nanosecond event detection was performed at 50 nanoseconds. **There were no events recorded.**

2mm Connector

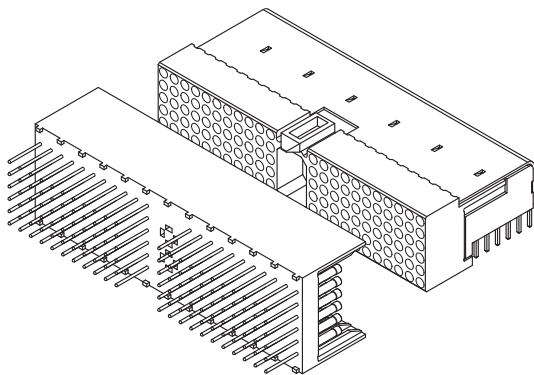

2mm Connector Mated Pair

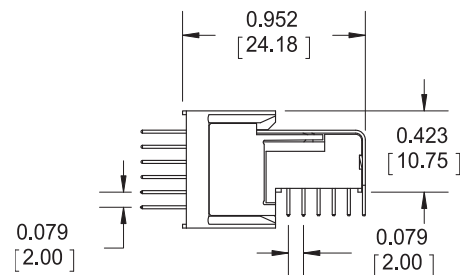

Dimensions are in inches [mm]

J0/P0 High Speed Electrical Performance

1. Differential S-parameter^{1,2}

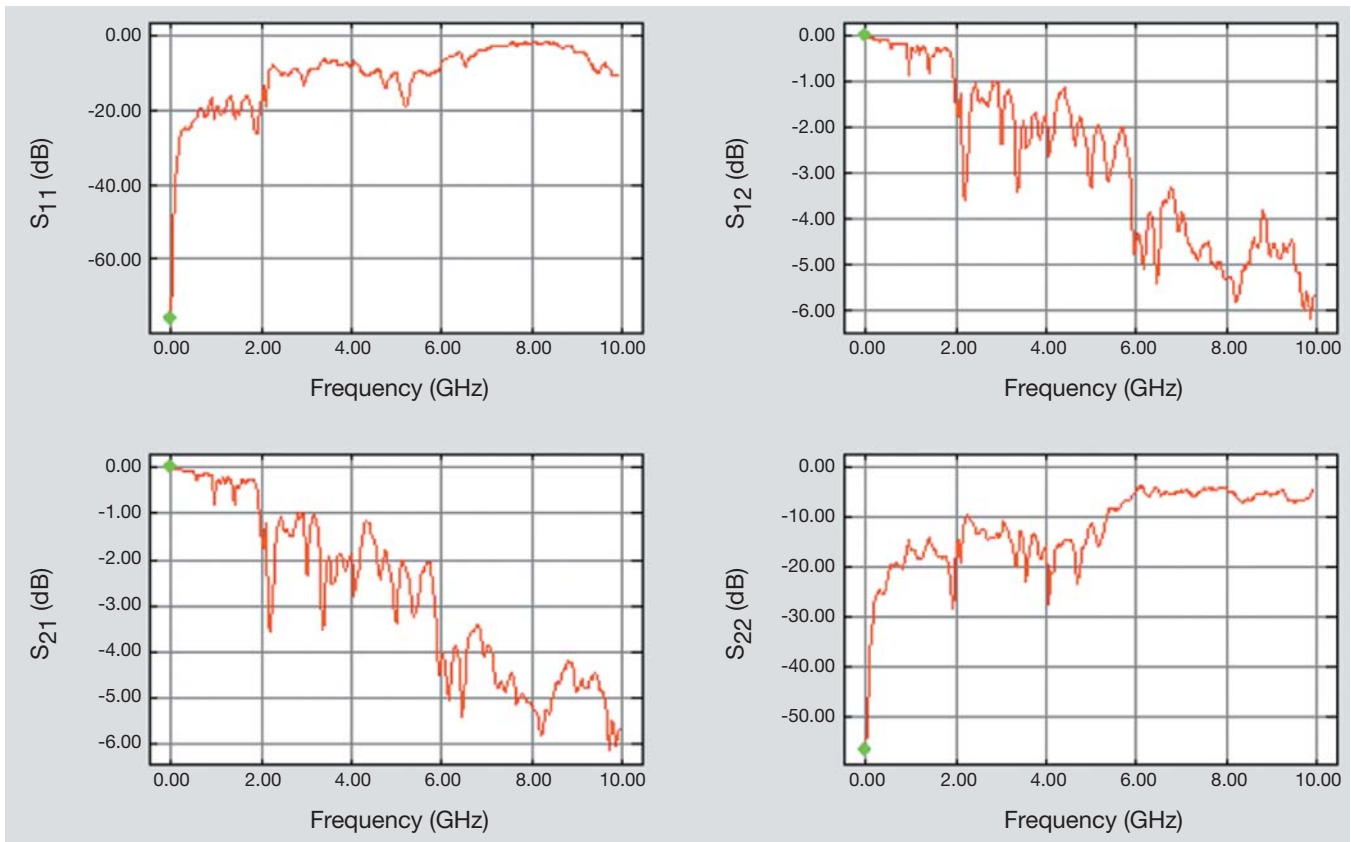

2. Propagation Delay and Skew

Propagation delay through the intrinsic connector assembly is estimated by making a measurement on the reflected signal received on the same broadband fixture that is used to obtain the full vector scattering parameters. In these measurements, there is no inclusion of any other pin lengths other than what is within the intrinsic connector.

Parameters	Connector Row				
	A	B	C	D	E
Propagation Delay (ps)	68	90	112	134	156
Skew (ps)	22	22	22	22	22
Maximum Data Rate ²	3.125 Gb/s				

NOTES:

- 1) Pattern illustrated in the figure on next page was used in the S-parameter and cross talk measurements.
- 2) Please refer to the full characterization test report for details.

Dimensions are in inches [mm]

3. Connector Eye-Pattern-Diagram^{1, 2}

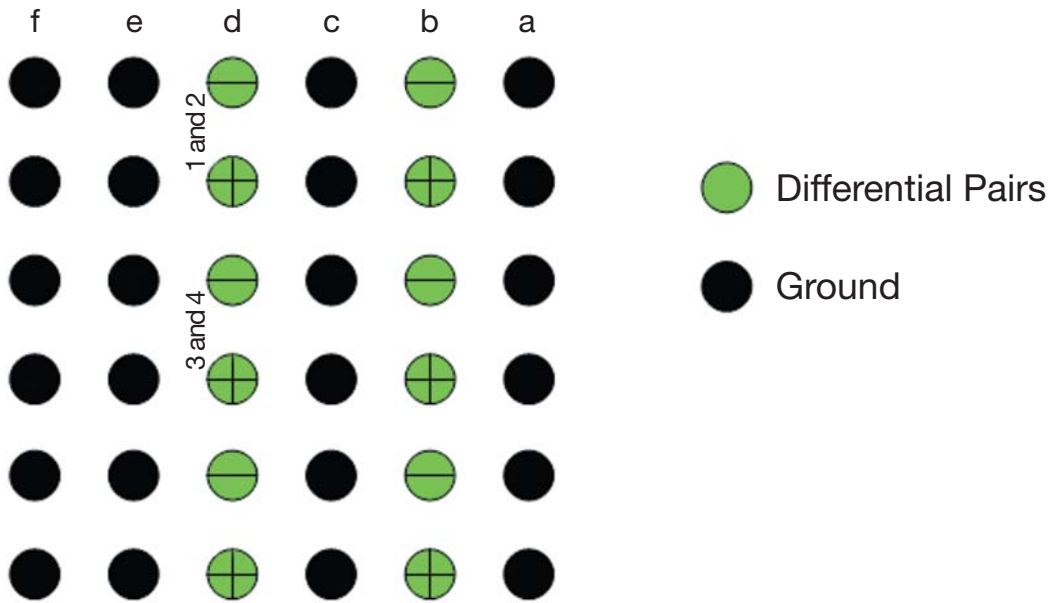
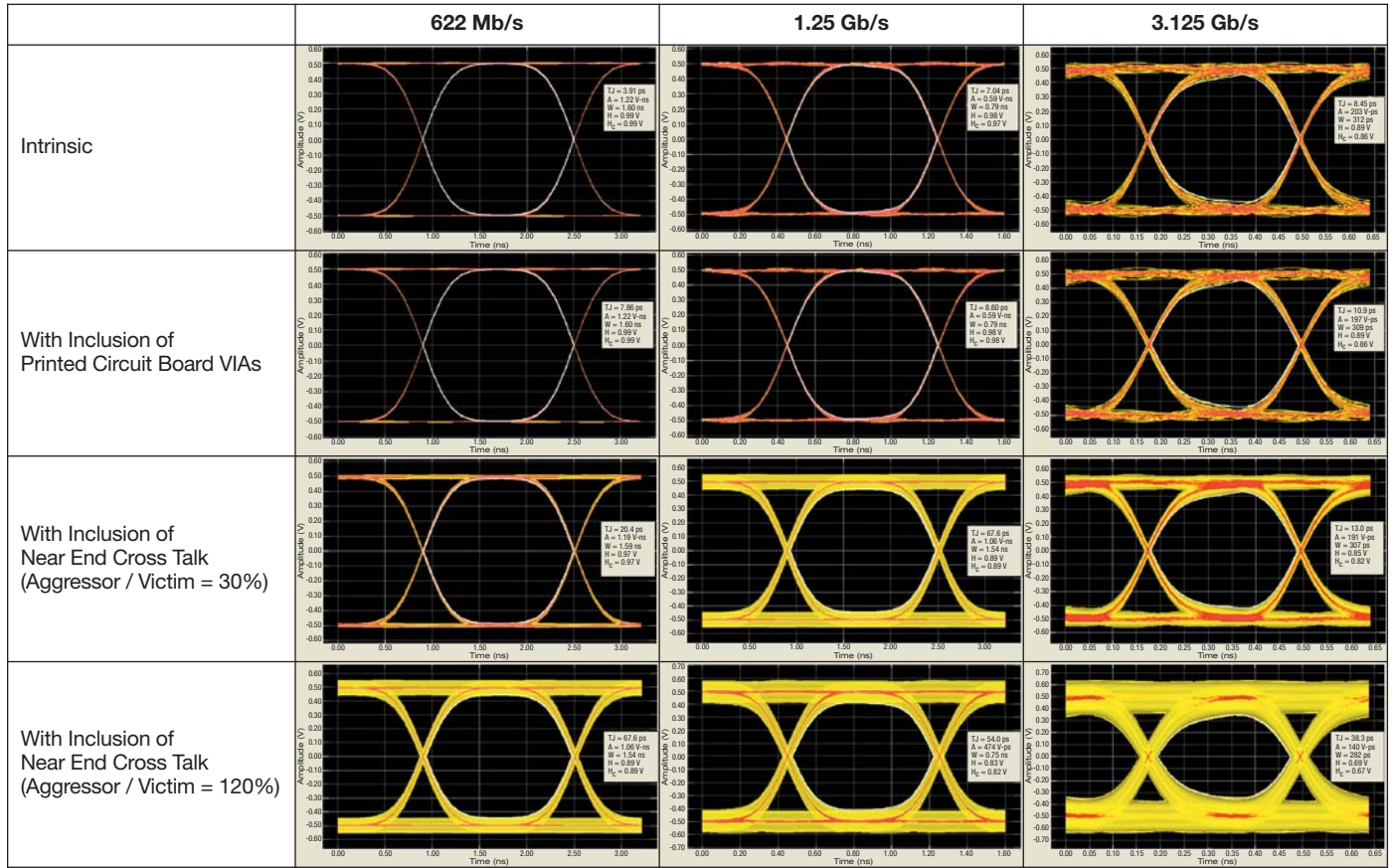

NOTES:
 1) Pattern illustrated in the figure above was used in the S-parameter and cross talk measurements.
 2) Please refer to the full characterization test report for details.

Dimensions are in inches [mm]

K2A Male - K2A110FMDTBH

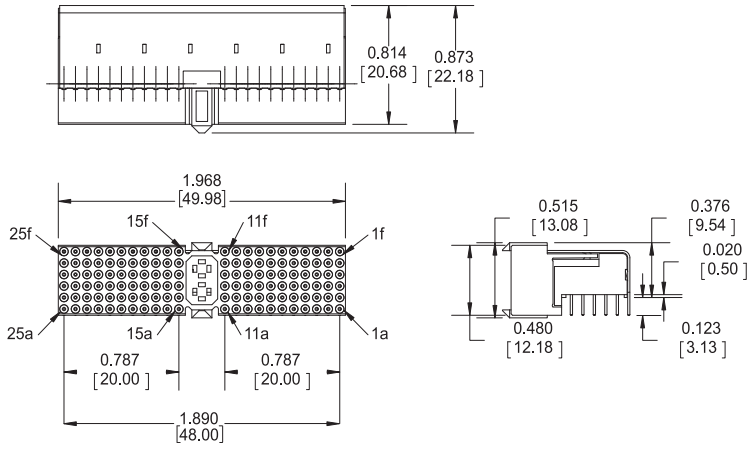

Printed Circuit Board Layout

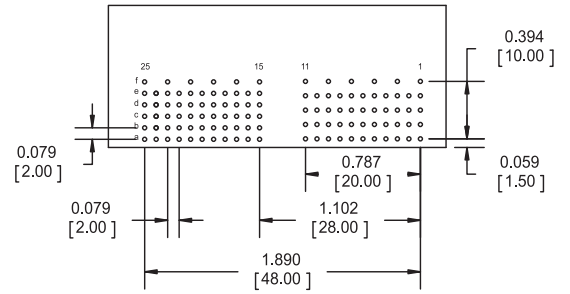

K2A Female - K2A110FFDTABH

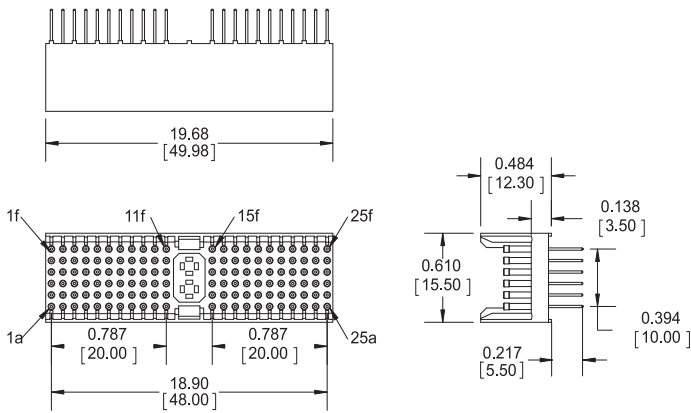

Printed Circuit Board Layout

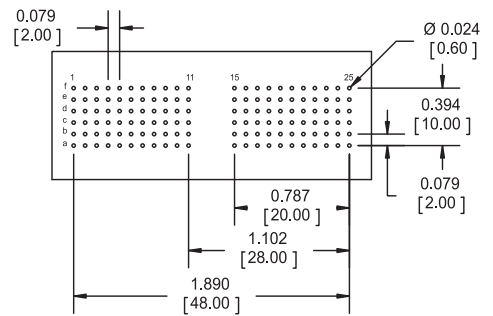

Dimensions are in inches [mm]

K2B Male

Printed Circuit Board Layout

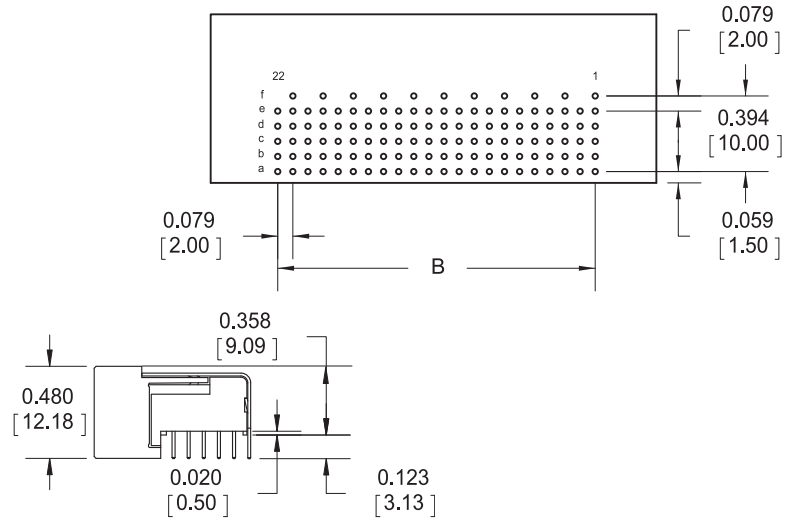
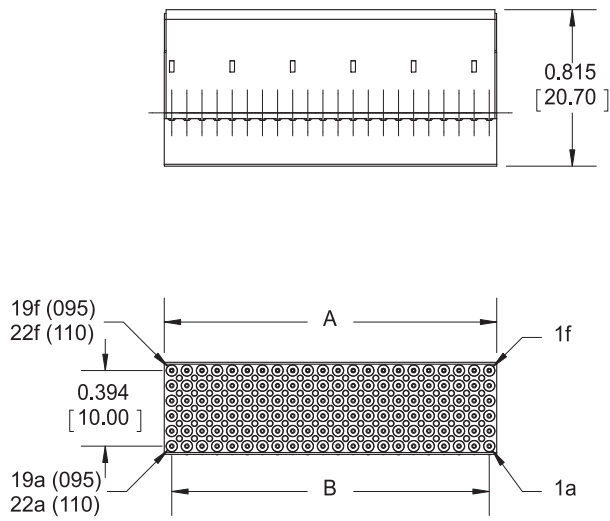

Connector Dimensions for K2B Male		
	K2B95FMD	K2B110FMD
A	1.495 [37.98]	1.731 [43.98]
B	1.417 [36.00]	1.654 [42.00]

Dimensions are in inches [mm]

K2B Female

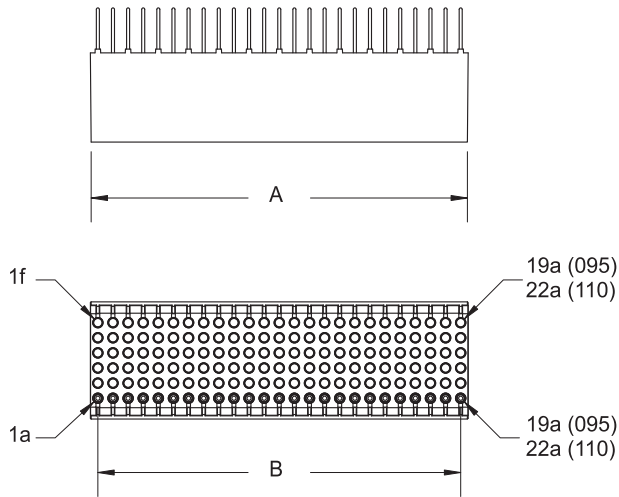

Printed Circuit Board Layout

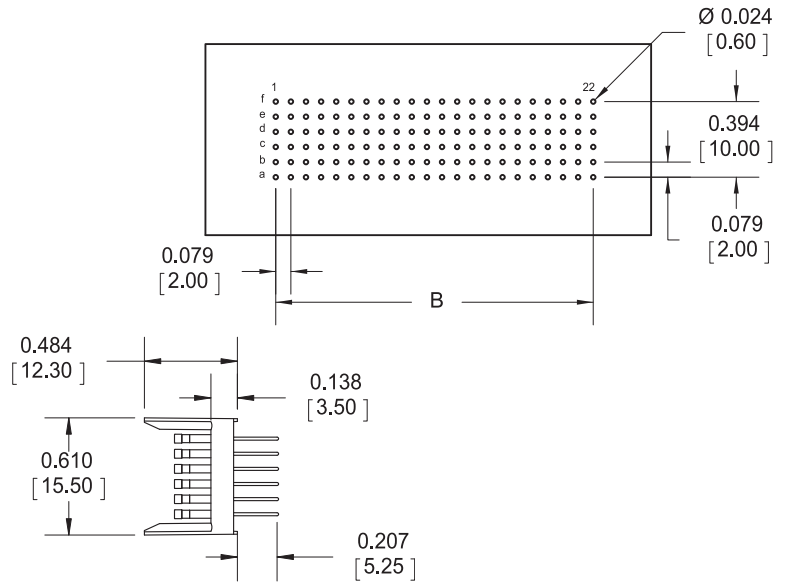

Connector Dimensions for K2B Female

	K2B95FFD	K2B110FFD
A	1.495 [37.98]	1.731 [43.98]
B	1.417 [36.00]	1.654 [42.00]

Dimensions are in inches [mm]

Ordering Information

K2
A
110
F
M
D
4
TBH

Connector Family	K2
Connector Style*	(Per IEC 1076-4-101) A = With multi-purpose center (MPC; polarization feature) B = Without MPC C = Extension module
Number of Signal Pins	110 = 110 contacts 095 = 95 contacts
Number of Rows	E = No shields (5 row) F = Top shield (6 row)
Contact Gender	M = Male F = Female
Terminal Styles	D = Straight dip solder C = Compliant (TBD) (backplane only)

Plating

TAH = 50µin gold over nickel (mating surface only)
Other surfaces gold flash over nickel (female contacts only)
TABH = Same as TAH with tin/lead (63/37) over nickel on contact terminations (female contacts only)
TH = 50µin gold over nickel (male contacts only)
TBH = Same as TH with tin/lead (63/37) over nickel on contact terminations (male contacts only)

Contact Terminal Length	Designation	Backplane Connector Tail Length	Daughter Board Connector Tail Length
	D	0.216 [5.50]	0.123 [3.12]
	D1	0.380 [9.65]	TBD
	D2	0.630 [16.00]	TBD
	D3	TBD	TBD
	D4	0.166 [4.22]	0.166 [4.22]
	D5	0.265 [6.73]	TBD

Quality Conformance Inspection = MIL-DTL 55302 Group A & B

* Pin one location per IEC 1076-4-101

NASA Goddard Part Numbers and Ordering Information

311P822
MC
110
AS
D4

Goddard Designator

Connector Gender Designation	MC = Male connector FC = Female connector MA = Male adapter FA = Female adapter FFA = Female-to-female adapter
Number of Contacts	110 = 110 contacts 095 = 95 contacts
Connector Style	A = With multi-purpose center (MPC; polarization feature) B = Without MPC

Solder Tail Length	Designation	Backplane Connector Tail Length	Daughter Board Connector Tail Length
	D	0.216 [5.50]	0.123 [3.12]
	D1	0.380 [9.65]	TBD
	D2	0.630 [16.00]	TBD
	D3	TBD	TBD
	D4	0.166 [4.22]	0.166 [4.22]
	D5	0.265 [6.73]	TBD

Solder Tail Finish

G = Gold flash over nickel
S = 63/37 tin/lead solder over nickel

Quality Conformance Inspection = NASA GSFC S-311-P-822 Table II

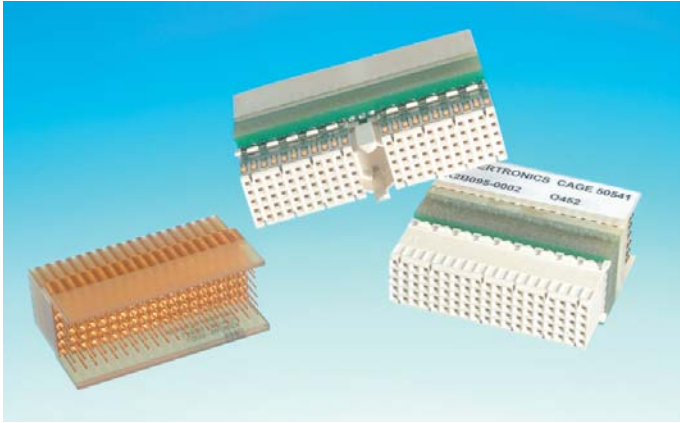

Subject to Export Control Procedure

cPCI Test Adapters and Solder Fixtures*

Designed to provide interface between commercial cPCI connectors and Hypertronics Hi-Rel cPCI connector series

- Hypertronics adapters provide a simple way to interface with commercial test equipment
- K2A110-0001, K2B110-0001 and K2B095-0001 adapt commercial cPCI daughter card connectors to Hypertronics backplane connectors
- K2A110-0002, K2B110-0002 and K2B095-0002 adapt commercial cPCI backplane connectors to Hypertronics daughter card connectors

*Adapters are not flight qualified

cPCI 1 Up Solder Fixtures - ZK2 Series

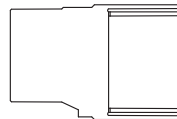
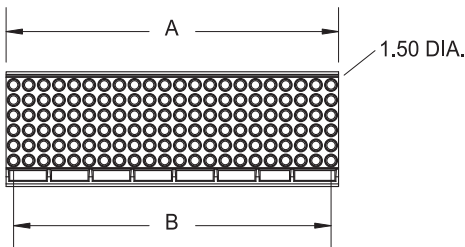
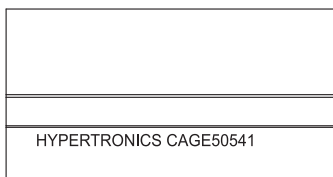

ZK2 series solder fixtures provide an economical method for stabilizing the socket contact during the hand soldering and reflow solder process for backplane connectors.

Marking to include fixture part number, cage code and date code.

Fixture Number	Used with K2A	A	B
ZK2095-005	K2B95FFDTABH	1.495 [37.98]	1.417 [36.00]
ZK2110-008	K2B110FFDTABH	1.731 [43.98]	1.654 [42.00]
ZK2110-007	K2A110FFDTABH	1.968 [49.98]	1.890 [48.00]

Recommended 6U Solder Alignment Fixturing and Tooling

Alignment Tool	Description	Work Instructions
T2066	Standard Backplane cPCI 6U	S50475
T2082	Standard 6U cPCI Daughtercard	S50476

Consult factory for alignment tool and work instructions information

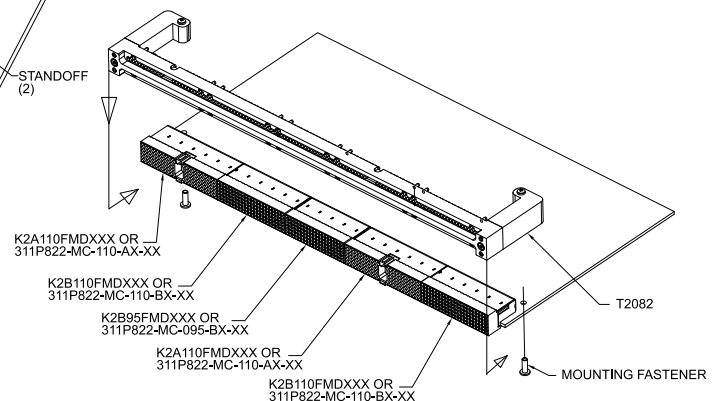
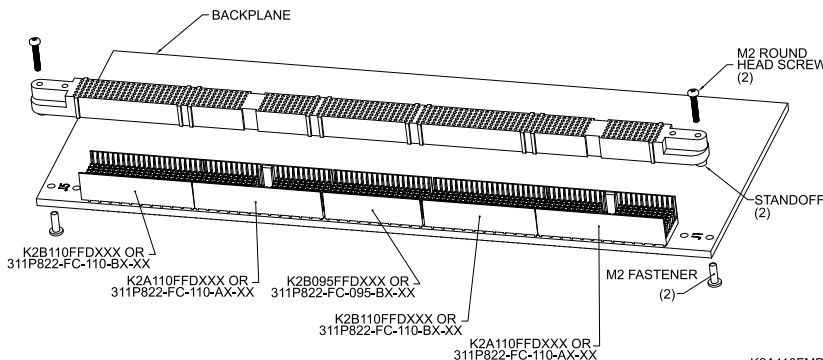

Dimensions are in inches [mm]

cPCI Mated Adapter - K2xxx-0001

Used to mate a commercial daughter board connector to a Hypertronics mother board connector.

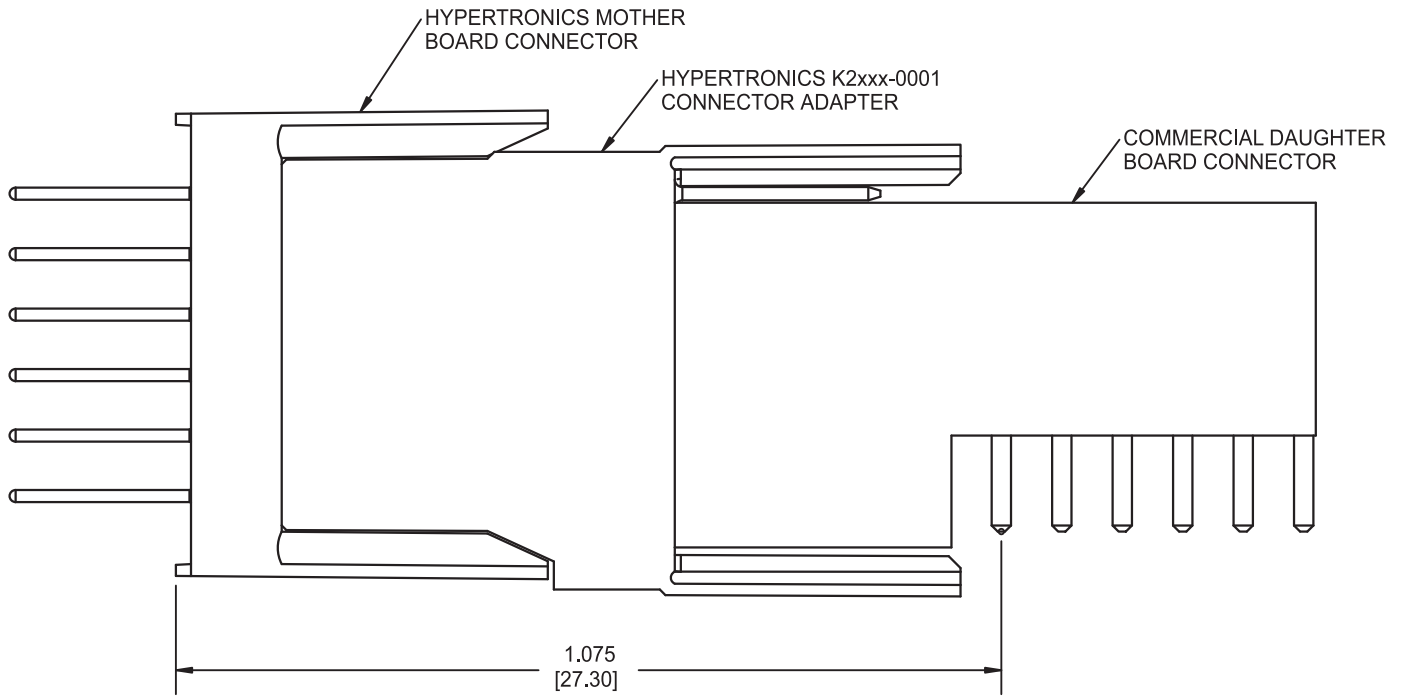

K2A110-0001

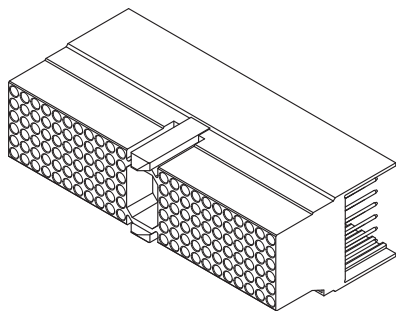

K2B110-0001

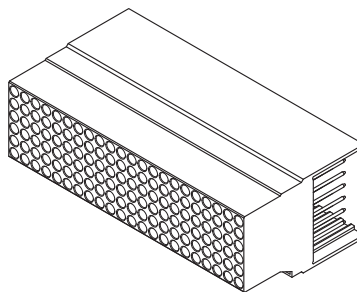

K2B095-0001

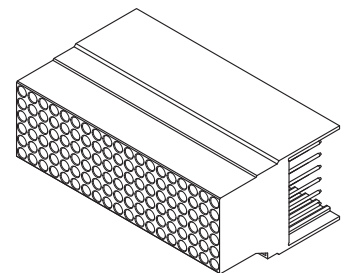

K2A110-0001, K2B110-0001 and K2B095-0001 adapt commercial cPCI daughter card connectors to Hypertronics backplane connectors.

K2A110-0001

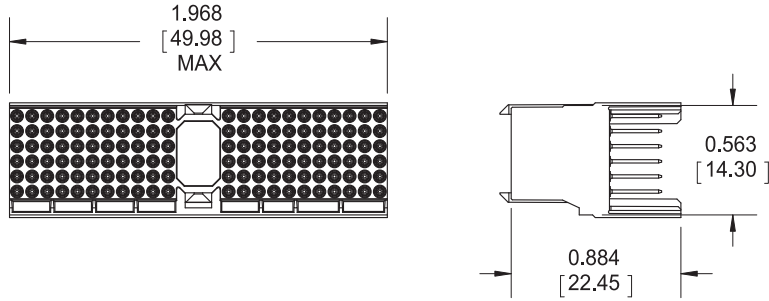

K2B110-0001

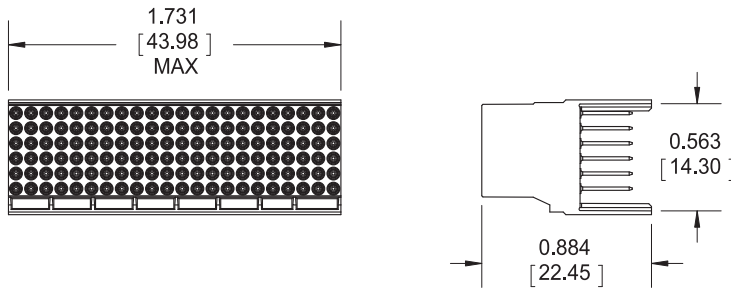

K2B095-0001

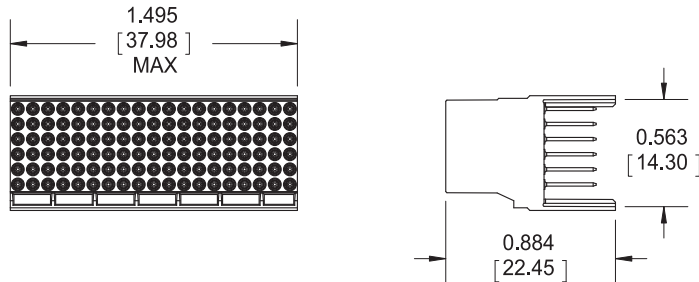

Dimensions are in inches [mm]

cPCI Mated Adapter – K2xxx-0002

Used to mate a commercial mother board connector to a Hypertronics daughter board connector.

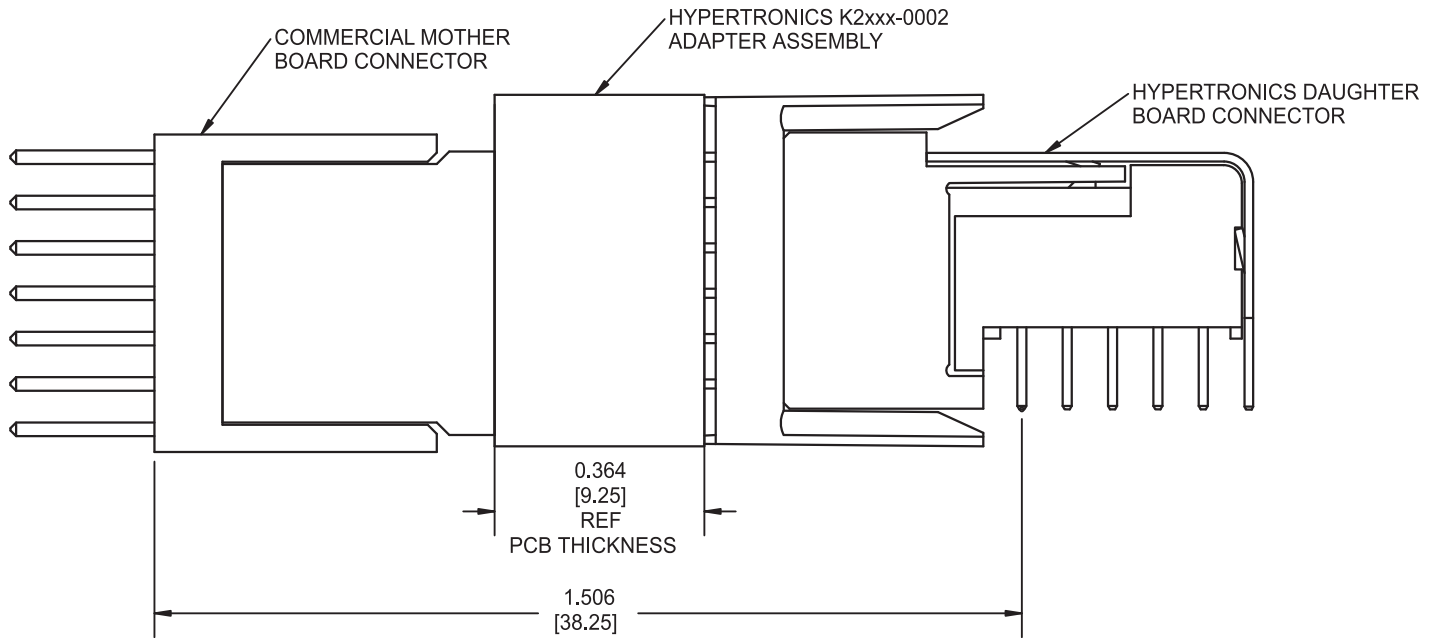

K2A110-0002

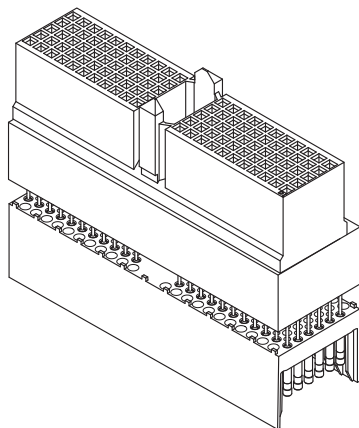

K2B110-0002

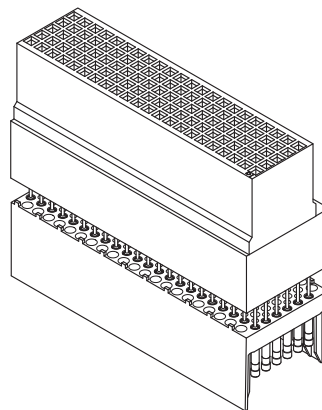

K2B095-0002

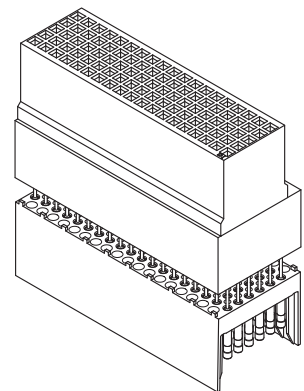

Dimensions are in inches [mm]

K2A110-0002, K2B110-0002 and K2B095-0002 adapt commercial cPCI backplane connectors to Hypertronics daughter card connectors.

K2A110-0002

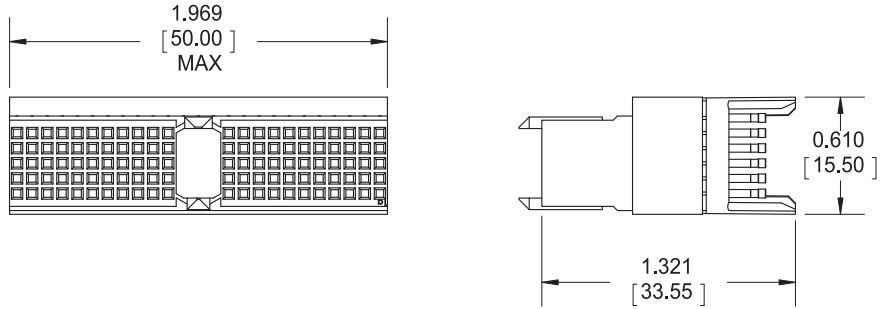

K2B110-0002

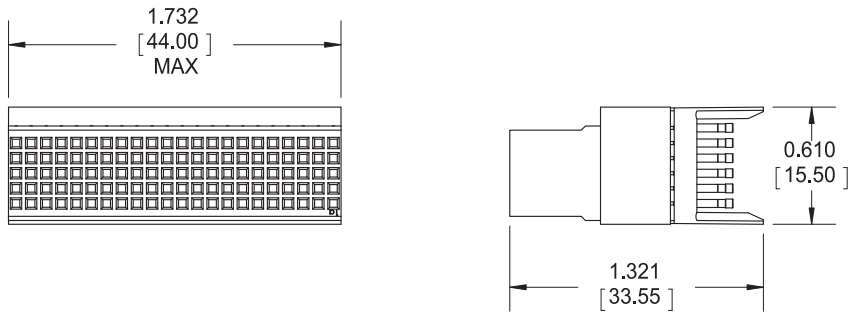

K2B095-0002

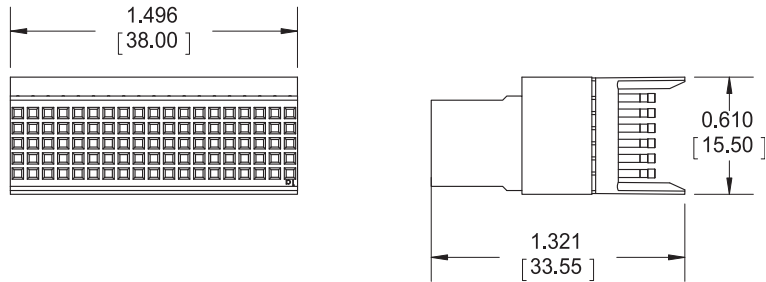

Dimensions are in inches [mm]

MPC (Multi-Purpose Center) Keying Options Available

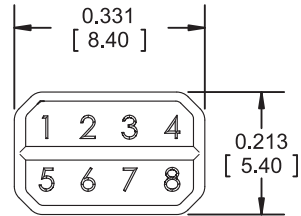
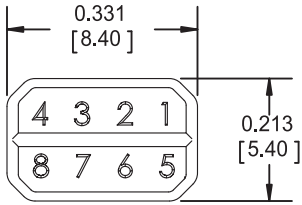
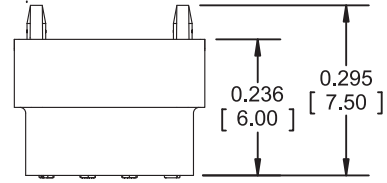
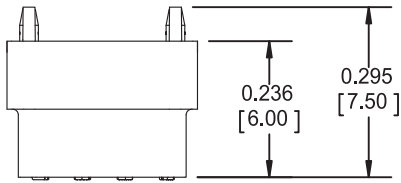

Matching Codes Male Side (PCB)	Keyset MPC Key P/N
1234	ZK2000-002-01
1236	ZK2000-002-03
1237	ZK2000-002-04
1238	ZK2000-002-05
1246	ZK2000-002-07
1247	ZK2000-002-08
1268	ZK2000-002-14
1345	ZK2000-002-16
1348	ZK2000-002-19
1357	ZK2000-002-21
1358	ZK2000-002-22
1378	ZK2000-002-25
1457	ZK2000-002-27
1467	ZK2000-002-29
1478	ZK2000-002-31
1568	ZK2000-002-33
1678	ZK2000-002-35
2346	ZK2000-002-37
3467	ZK2000-002-59
3478	ZK2000-002-61
4678	ZK2000-002-69

Matching Codes Female Side (Backplane)	Keyset MPC Key P/N
5678	ZK2000-001-01
4578	ZK2000-001-03
4568	ZK2000-001-04
4567	ZK2000-001-05
3578	ZK2000-001-07
3568	ZK2000-001-08
3457	ZK2000-001-14
2678	ZK2000-001-16
2567	ZK2000-001-19
2468	ZK2000-001-21
2467	ZK2000-001-22
2456	ZK2000-001-25
2368	ZK2000-001-27
2358	ZK2000-001-29
2356	ZK2000-001-31
2347	ZK2000-001-33
2345	ZK2000-001-35
1578	ZK2000-001-37
1258	ZK2000-001-59
1256	ZK2000-001-61
1235	ZK2000-001-69

Dimensions are in inches [mm]