

KA3027D2

4-Channel Motor Driver

Features

- 3-Channel Balanced TransformerLess(BTL) driver
- 1-Channel forward-Reverse control DC motor driver
- Built-in thermal shutdown circuit
- Built-in mute circuit
- Operating supply voltage: 4.5~5.5V
- Corresponds to 3.3V or 5V DSP

Description

The KA3027D2 is a monolithic IC, suitable for a 1-ch (forward.reverse) control DC motor driver and a 3-ch motor driver which drives the focus actuator,tracking actuator, and sled motor of a CD-media system.

28-SSOPH-300



Typical Applications

- Notebook compact disk ROM (CD-ROM)
- Other portable compact disk media

Ordering Information

Device	Package	Operating Temp.
KA3027D2	28-SSOPH-300	-35 °C ~ 85 °C
KA3027D2TF	28-SSOPH-300	-35 °C ~ 85 °C

Pin Assignments

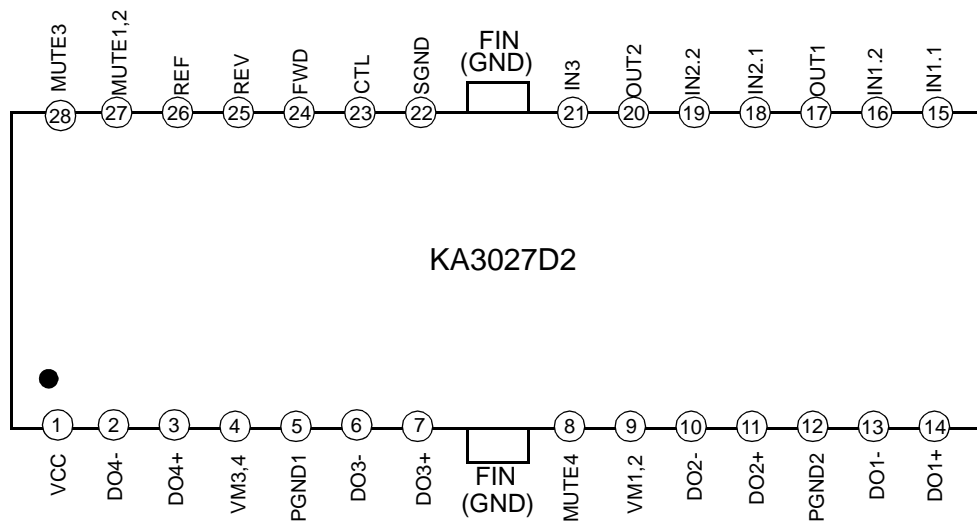

Pin Definitions

Pin Number	Pin Name	I/O	Pin Function Description
1	VCC	-	Signal VCC
2	DO4-	O	Drive4 Output (-)
3	DO4+	O	Drive4 Output (+)
4	VM3, 4	-	BTL CH3, 4 Power VCC
5	PGND1	-	CH3, 4 Power Ground
6	DO3-	O	Drive3 Output (-)
7	DO3+	O	Drive3 Output (+)
8	MUTE4	-	CH4 Mute
9	VM1,2	-	BTL CH1, 2 Power VCC
10	DO2-	O	Drive2 Output (-)
11	DO2+	O	Drive2 Output (+)
12	PGND2	-	CH1,2 Power Ground
13	DO1-	O	Drive1 Output (-)
14	DO1+	O	Drive1 Output (+)
15	IN1.1	I	OP-AMP CH1 Input (+)
16	IN1.2	I	OP-AMP CH1 Input (-)
17	OUT1	O	OP-AMP CH1 Output
18	IN2.1	I	OP-AMP CH2 Input (+)
19	IN2.2	I	OP-AMP CH2 Input (-)
20	OUT2	O	OP-AMP CH2 Output
21	IN3	I	OP-AMP CH3 Input
22	SGND	-	Signal Ground
23	CTL	I	CH4 Motor Speed Control
24	FWD	I	CH4 Forward
25	REV	I	CH4 Reverse
26	REF	I	Bias Voltage Input
27	MUTE1,2	I	CH1, 2 Mute
28	MUTE3	I	CH3 Mute

Internal Block Diagram

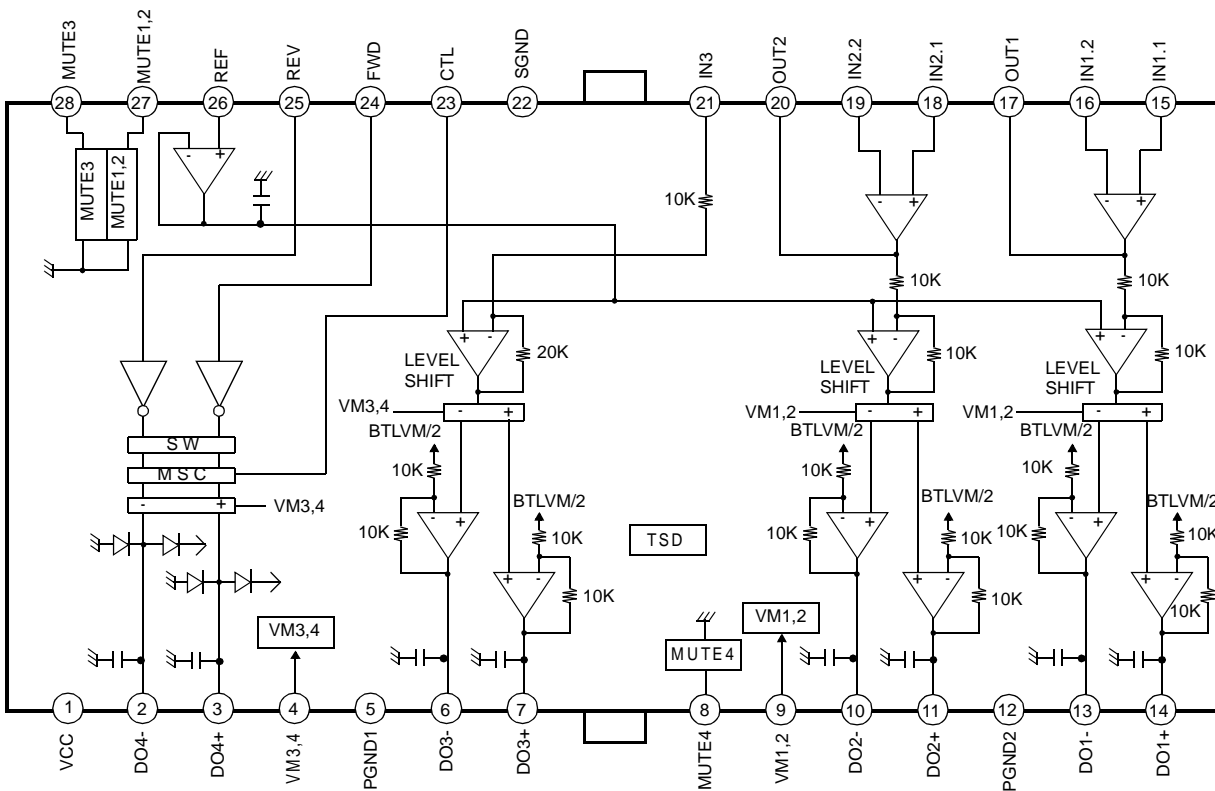

Equivalent Circuits

MUTE INPUT	POWER OUTPUT
CH3 LEVEL SHIFT INPUT	SIGNAL REFERENCE INPUT
ERROR AMP INPUT	LOADING CONTROL INPUT
ERROR AMP OUTPUT	LOADING LOGIC INPUT

Absolute Maximum Ratings (Ta = 25°C)

Parameter	Symbol	Value	Unit
Maximum supply voltage	V _{CCmax}	7	V
Power dissipation	P _D	1.4 ^{note}	W
Operating temperature range	T _{OPR}	-35 ~ +85	°C
Storage temperature range	T _{STG}	-55 ~ +150	°C

NOTE:

1. When mounted on a 76.2mm × 114mm × 1.57mm PCB (Phenolic resin material).
2. Power dissipation reduces 11.2mW/°C for using above Ta = 25°C
3. Do not exceed P_D and SOA(Safe operating area).

Power Dissipation Curve

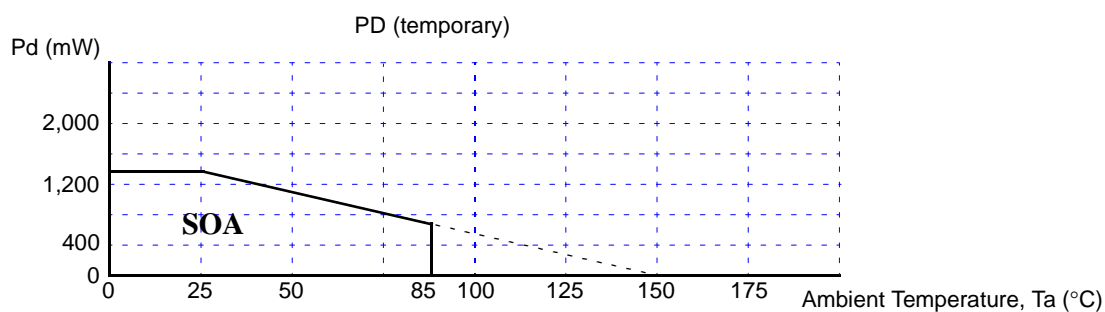

Recommended Operating Conditions (Ta = 25°C)

Parameter	Symbol	Min	Typ	Max	Unit
Supply Voltage	V _{CC}	4.5	-	5.5	V

Electrical Characteristics

(Unless otherwise specified, $T_a = 25\text{ }^\circ\text{C}$, $V_{CC} = V_{M1,2} = V_{M3,4} = 5\text{V}$)

Parameter	Symbol	Conditions	Min.	Typ.	Max.	Units
Quiescent Current	I_{CC}	$V_{in} = 0\text{V}$	-	8	12	mA
CH Mute On Current	I_{MUTEch}	Pin27, Pin28, Pin8 = GND	-	1	3	mA
CH Mute On Voltage	V_{MONch}	Pin27, Pin28, Pin8 = Variation	-	-	0.5	V
CH Mute Off Voltage	V_{MOFFch}	Pin27, Pin28, Pin8 = Variation	2	-	-	V
DRIVE CIRCUIT						
Input Offset Voltage	V_{IO}	-	-20	-	+20	mV
Output Offset Voltage	V_{OO}	$V_{IN} = 2.5\text{V}$	-40	-	+40	mV
Maximum Output Voltage1	V_{OM1}	$R_L = 8\Omega$ (CH1, 2)	2.7	3.4	-	V
Maximum Output Voltage2	V_{OM2}	$R_L = 24\Omega$ (CH3)	3	3.8	-	V
Closed Loop Voltage Gain1	G_{VC1}	$f = 1\text{kHz}$, $V_{in} = 0.1V_{RMS}$ (CH1, 2)	10.5	12	13.5	dB
Closed Loop Voltage Gain2	G_{VC2}	$f = 1\text{kHz}$, $V_{in} = 0.1V_{RMS}$ (CH3)	16	18	20	dB
Ripple Rejection Ratio	RR	$V_{IN} = 0.1V_{RMS}$, $f = 120\text{Hz}$	-	60	-	dB
Slew Rate	SR	$V_O = 2V_{P-P}$, $f = 120\text{kHz}$	-	0.8	-	V/us
ERROR OP AMP CIRCUIT						
Input Offset Voltage	V_{OFOP}	-	-7	-	+7	mV
Input Bias Current	I_{BOP}	-	-	-	300	nA
High Level Output Voltage	V_{OHOP}	-	4.5	4.8	-	V
Low Level Output Voltage	V_{OLOP}	-	-	0.2	0.5	V
Output Sink Current	I_{SINK}	$R_L = 1\text{K}\Omega$	2	4	-	mA
Output Source Current	I_{SOURCE}	$R_L = 1\text{K}\Omega$	2	4	-	mA
Open Loop Voltage Gain	G_{VO}	$V_{IN} = -75\text{dB}$, $f = 1\text{kHz}$	-	75	-	dB
Ripple Rejection Ratio	RR_{OP}	$V_{IN} = -20\text{dB}$, $f = 120\text{Hz}$	-	65	-	dB
Slew Rate	SR_{OP}	$f = 120\text{kHz}$, $2V_{p-p}$	-	1	-	V/us
Common Mode Rejection Ratio	CMRR	$V_{IN} = -20\text{dB}$, $f = 1\text{kHz}$	-	80	-	dB
Common Mode Input Range	V_{ICM}	-	-0.3	-	4.5	V
TRAY DRIVE CIRCUIT ($V_{CC} = V_{M3,4} = 5\text{V}$, $R_L = 45\Omega$)						
Input High Level Voltage	V_{IH}	-	2	-	-	V
Input Low Level Voltage	V_{IL}	-	-	-	0.5	V
Output Voltage	V_O	$V_{CTL} = 3.5\text{V}$	2.8	3.5	4.2	V
Output Load Regulation	ΔV_{RL}	-	-	300	700	mV
Output Offset Voltage1	V_{OO1}	$V_{IN} = 5\text{V}, 5\text{V}$	-10	-	+10	mV
Output Offset Voltage2	V_{OO2}	$V_{IN} = 0\text{V}, 0\text{V}$	-10	-	+10	mV

Application Information

1. REFERENCE INPUT

Pin 26 (REF) is a reference Input pin.

1) Reference Input

The applied voltage at the reference input pin must be between 1.5 (V) and 3.5 (V), when $V_{cc} = 5V$.

2. SEPARATED CHANNEL MUTE FUNCTION

These pins are used for individual channel mute operation.

- 1) When the mute pins (pin27, 28 and 8) are Low level, the mute circuits are enabled and the output circuits are muted.
- 2) When the voltages of the mute pins (pin27, 28 and 8) are High level, the mute circuits are disabled and the output circuits operate normally.
- 3) If the chip temperature rises above 175 °C, then the thermal shutdown (TSD) circuit is activated and the output circuits are muted.

Mute1, 2 (pin 27)-CH1, 2 mute control input pin.

Mute3 (pin 28)-CH3 mute control input pin. Mute4(pin8) - CH4 mute control input pin.

3. PROTECTION FUNCTION

Thermal Shutdown (TSD)

- 1) If the chip temperature rises above 175 °C the thermal shutdown (TSD) circuit is activated and the output circuit is in the Mute state, that is Off state.

The TSD circuit has a temperature hysteresis of 25 °C.

4. FOCUS, TRACKING ACTUATOR, SLED MOTOR DRIVE CIRCUIT

- 1) The reference voltage REF is given externally through pin 26.
- 2) The error amp output signal is amplified by $R2/R1$ and then fed to the level shift circuit.
- 3) The level shift circuit produces the differential output voltages and drives the two output power amplifiers.
Since the differential gain of the output amplifiers is equal to $2 \times (1 + R4/R3)$, the output signal of the error amp is amplified by $(R2/R1) \times 2 \times (1 + R4/R3)$.
- 4) If the total gain is insufficient, the input error amp can be used to increase the gain.
- 5) The bias voltage (V_r) is about a half of the supply voltage (V_M).

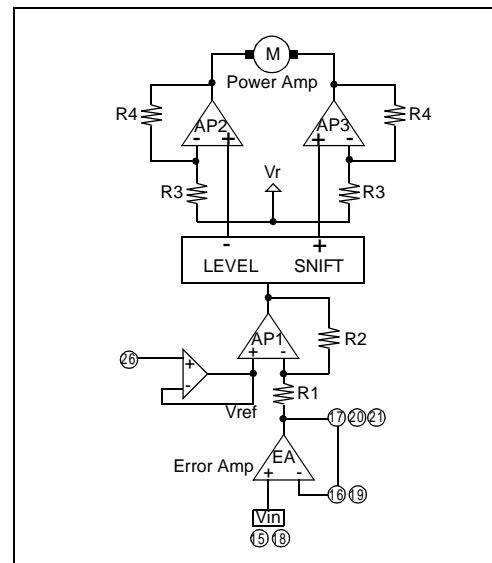

5. TRAY MOTOR DRIVE CIRCUIT

1) Rotational Direction Control

- The forward and reverse rotational direction is controlled by FWD (pin 24) and REV (pin 25) inputs. Conditions are as follows.
- V_r (Power reference voltage) is $(V_{M34} - V_{BE}) / 2$

Input		Output		
FWD	REV	DO4+	DO4-	State
H	H	V_r	V_r	Brake
H	L	H	L	Forward
L	H	L	H	Reverse
L	L	V_r	V_r	Brake

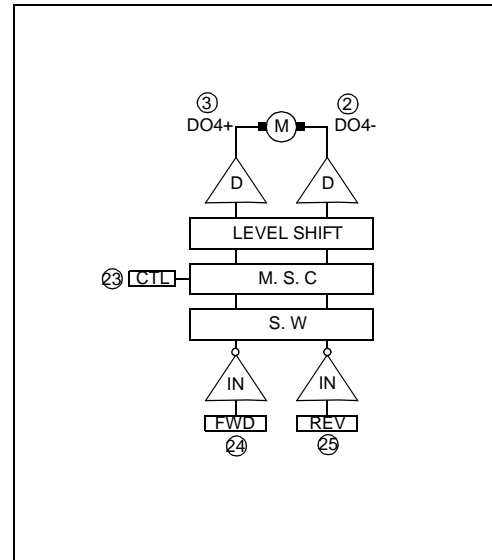

2) Motor Speed Control

- The motor speed is proportional to the differential voltage between the pin3(DO4+) and the pin2(DO4-).
- By applying the voltage to the pin23 of CTL, the motor speed can be controlled and it is linearly proportional to the applied control voltage.
- When both $V_{M3,4}$ and V_{cc} are 5V, and the applied control voltage is higher than 4V, the motor speed is not proportional to the control voltage but the motor speed becomes constant.
- If the pin23 is opened, the motor torque becomes maximum.
- The maximum output swing is 3.8V, when $V_{M3,4}$ and V_{cc} are 5V.

Typical Performance Characteristics

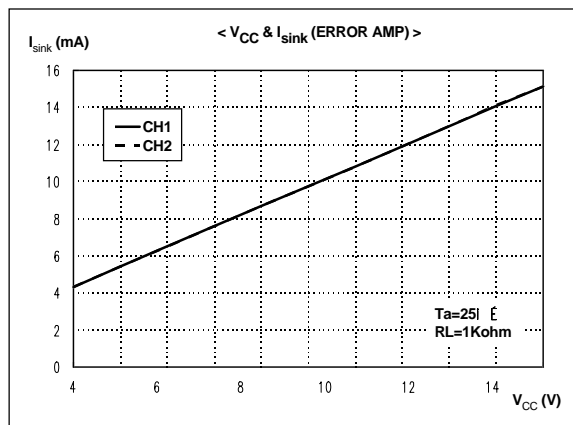
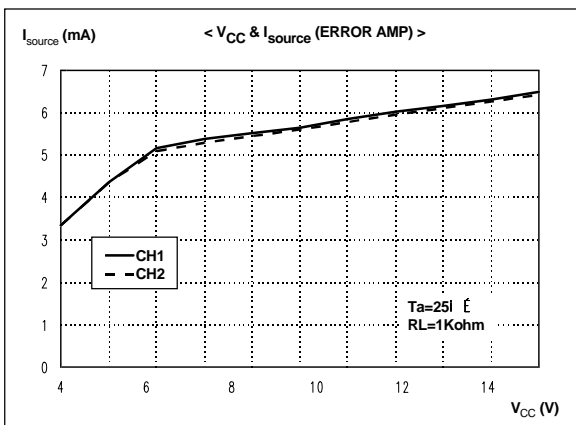
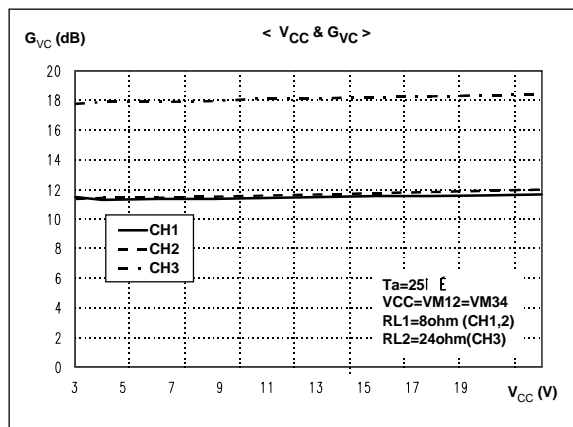
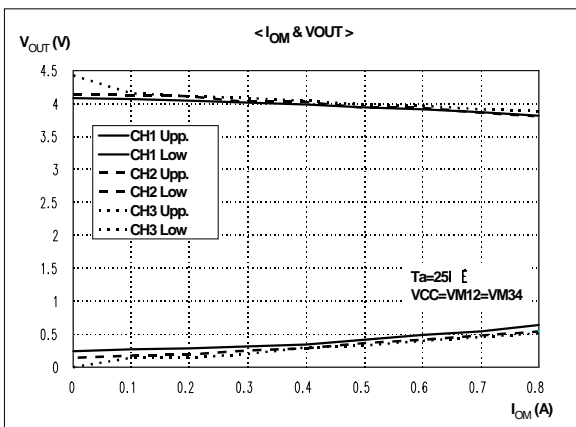
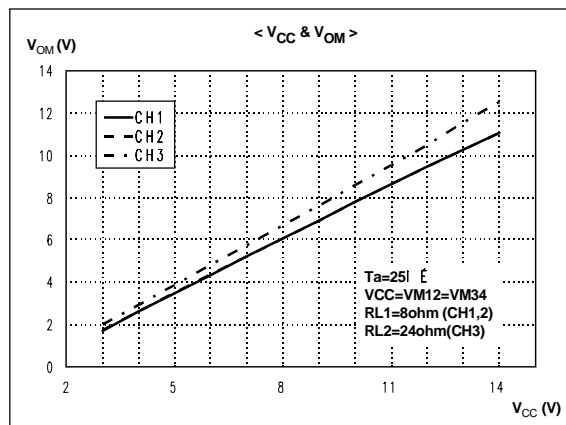
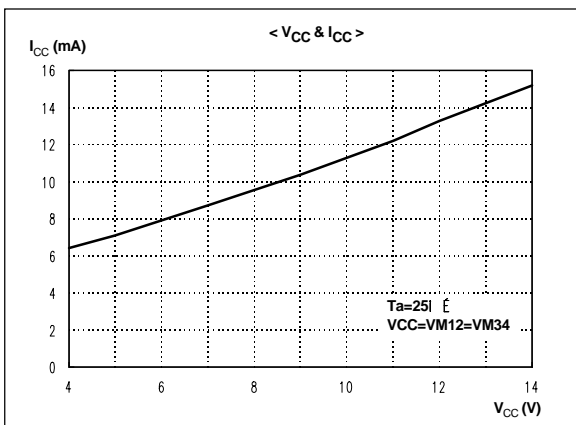

Typical Performance Characteristics (Continued)

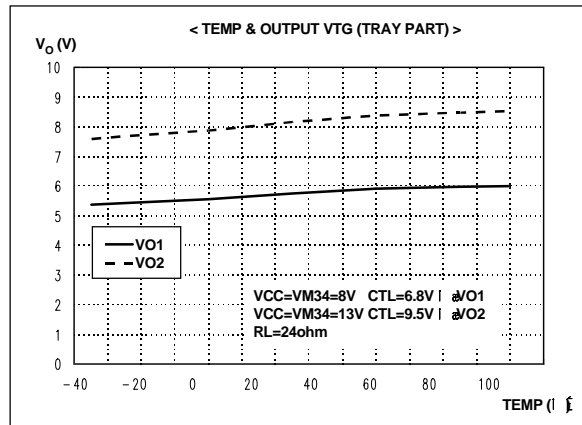
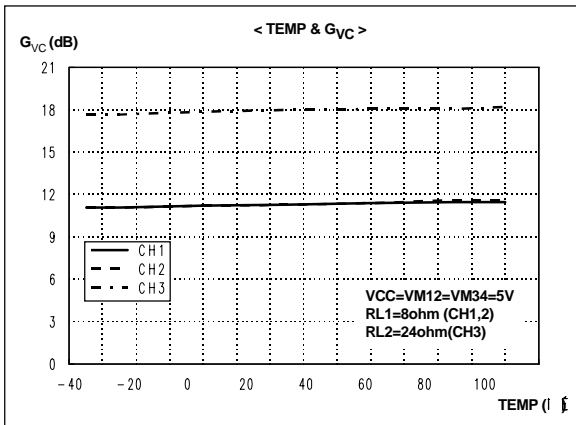
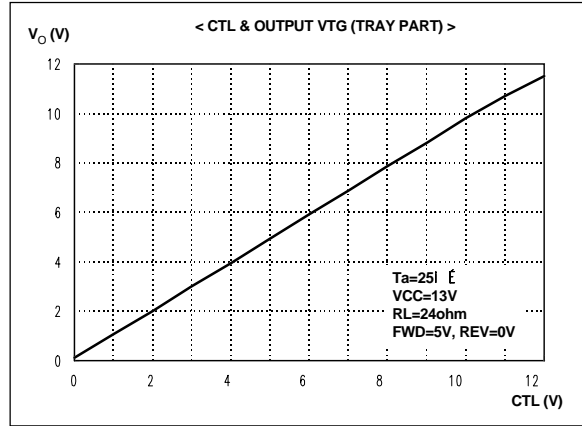
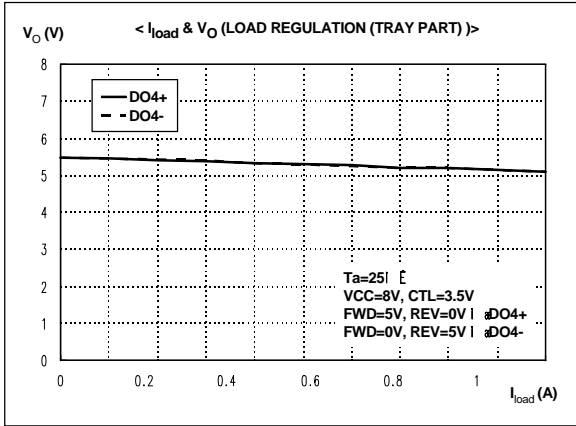

Typical Application Circuits 1

(Differential PWM Control Mode)

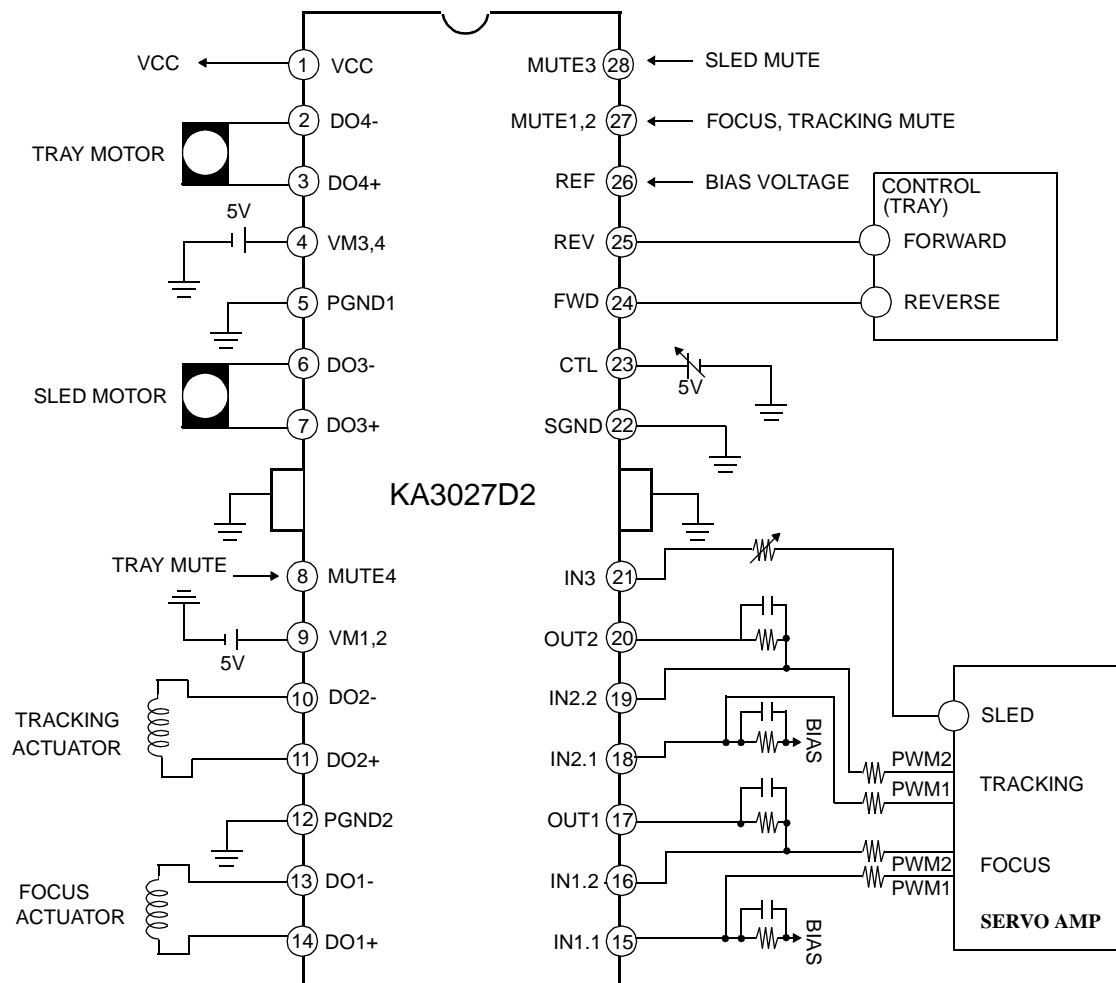

Thermal Shut Down Circuit

The IC overheats above 175°C and fails when overload condition continues for a long time. So, KA3027D2 has a thermal shut down circuit to prevent this condition.

Typical Application Circuits 2

(Voltage Control Mode)

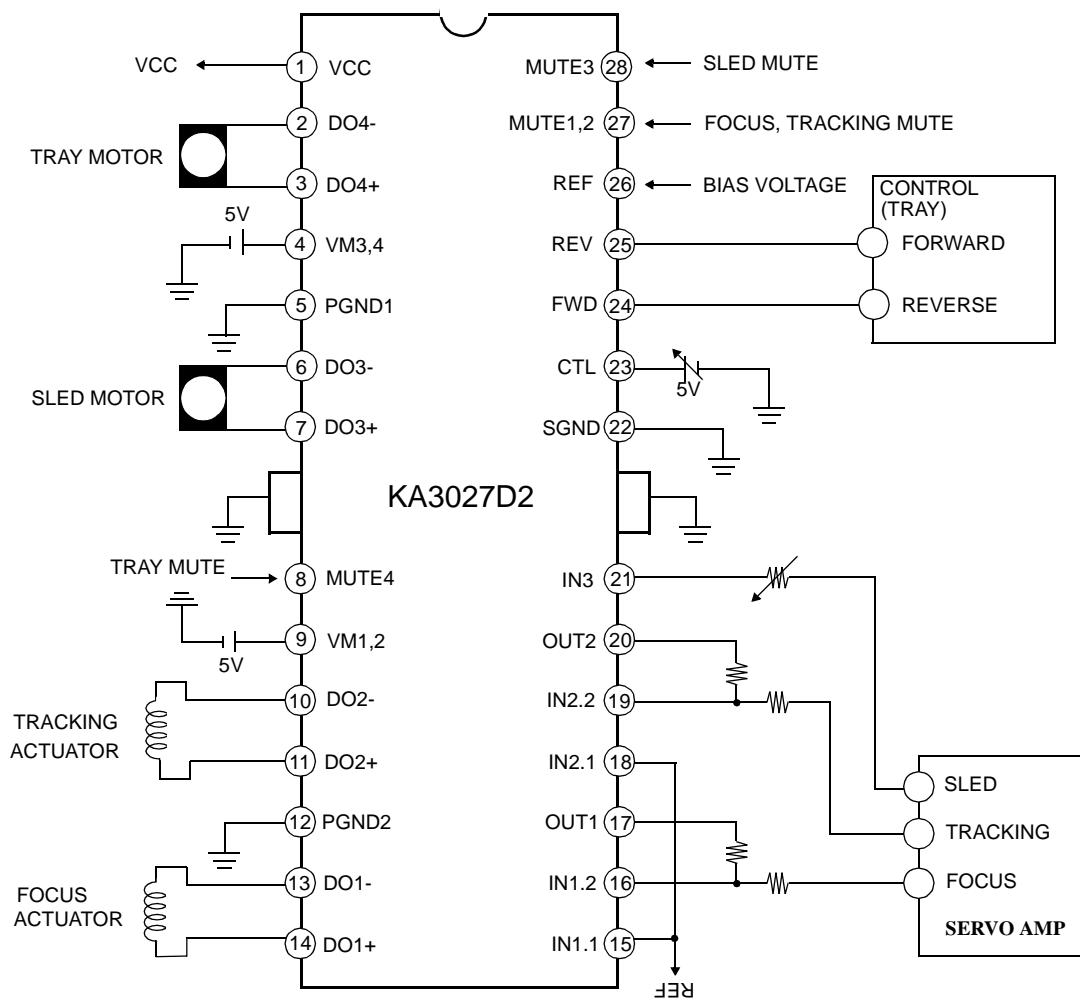

28-SSOPH-300

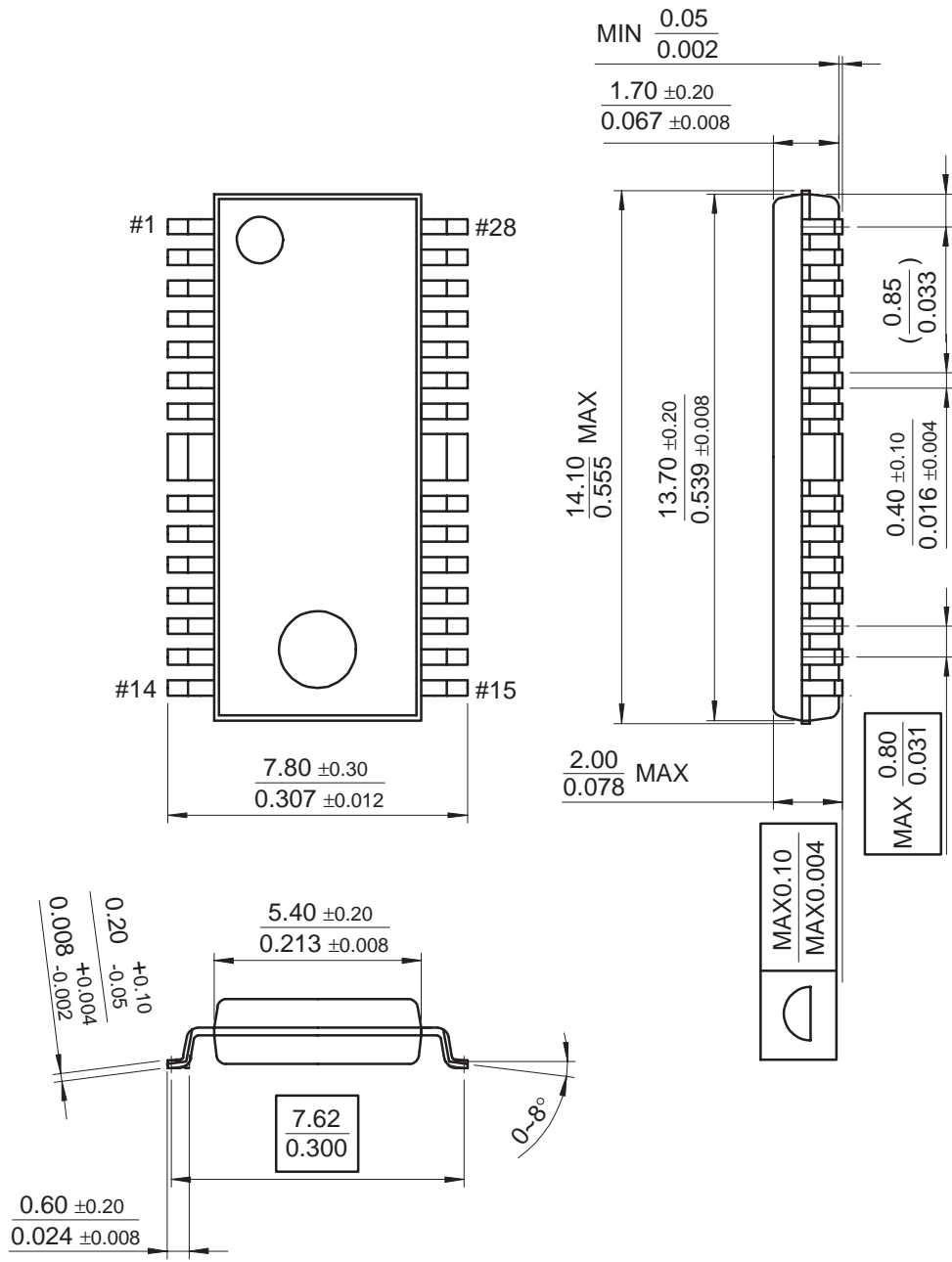

TRADEMARKS

The following are registered and unregistered trademarks Fairchild Semiconductor owns or is authorized to use and is not intended to be an exhaustive list of all such trademarks.

ACE ^x TM	FAST ^r TM	QFET TM	VCX TM
Bottomless TM	GlobalOptoisolator TM	QS TM	
CoolFET TM	GTO TM	QT Optoelectronics TM	
CROSSVOLT TM	HiSeC TM	Quiet Series TM	
DOME TM	ISOPANAR TM	SuperSOT TM -3	
E ² CMOS TM	MICROWIRE TM	SuperSOT TM -6	
EnSigna TM	OPTOLOGIC TM	SuperSOT TM -8	
FACT TM	OPTOPLANAR TM	SyncFET TM	
FACT Quiet Series TM	POP TM	TinyLogic TM	
FAST [®]	PowerTrench [®]	UHC TM	

DISCLAIMER

FAIRCHILD SEMICONDUCTOR RESERVES THE RIGHT TO MAKE CHANGES WITHOUT FURTHER NOTICE TO ANY PRODUCTS HEREIN TO IMPROVE RELIABILITY, FUNCTION OR DESIGN. FAIRCHILD DOES NOT ASSUME ANY LIABILITY ARISING OUT OF THE APPLICATION OR USE OF ANY PRODUCT OR CIRCUIT DESCRIBED HEREIN; NEITHER DOES IT CONVEY ANY LICENSE UNDER ITS PATENT RIGHTS, NOR THE RIGHTS OF OTHERS.

LIFE SUPPORT POLICY

FAIRCHILD'S PRODUCTS ARE NOT AUTHORIZED FOR USE AS CRITICAL COMPONENTS IN LIFE SUPPORT DEVICES OR SYSTEMS WITHOUT THE EXPRESS WRITTEN APPROVAL OF FAIRCHILD SEMICONDUCTOR CORPORATION. As used herein:

1. Life support devices or systems are devices or systems which, (a) are intended for surgical implant into the body, or (b) support or sustain life, or (c) whose failure to perform when properly used in accordance with instructions for use provided in the labeling, can be reasonably expected to result in significant injury to the user.
2. A critical component is any component of a life support device or system whose failure to perform can be reasonably expected to cause the failure of the life support device or system, or to affect its safety or effectiveness.

PRODUCT STATUS DEFINITIONS

Definition of Terms

Datasheet Identification	Product Status	Definition
Advance Information	Formative or In Design	This datasheet contains the design specifications for product development. Specifications may change in any manner without notice.
Preliminary	First Production	This datasheet contains preliminary data, and supplementary data will be published at a later date. Fairchild Semiconductor reserves the right to make changes at any time without notice in order to improve design.
No Identification Needed	Full Production	This datasheet contains final specifications. Fairchild Semiconductor reserves the right to make changes at any time without notice in order to improve design.
Obsolete	Not In Production	This datasheet contains specifications on a product that has been discontinued by Fairchild semiconductor. The datasheet is printed for reference information only.