

OUTLINE

The Rx5RZ Series are CMOS-based voltage regulator ICs with high output voltage accuracy, low supply current, low dropout voltage and high ripple rejection. Each of these voltage regulator ICs consists of a voltage reference unit, an error amplifier, output voltage setting resistors, a current limit circuit and a chip enable circuit. (Provided two types of chip enable circuit ; "H" active and "L" active, that can be selected when order.)for A/B version

The output voltage of these ICs is fixed with high accuracy.

In addition to low supply current from CMOS process, the Rx5RZ Series may lengthen battery life through low dropout voltage and chip enable function thanks to the built-in low ON resistance transistor. Also when compared with conventional regulators that employ CMOS process, these ICs have superior ripple rejection, input transient response characteristic and load transient response characteristic thus making these product suitable for power supply for hand-held communication equipment.

Since the package for these ICs are the SOT-23-5 package and SOT89, high density mounting of the ICs on boards is possible.

FEATURES

- Ultra-Low Supply Current.....Typ. 20 μ A
- Ultra-Low Supply Current (Standby).....Typ. 0.1 μ A (for A/B version)
- High Accuracy Output Voltage \pm 2.0%
- High Ripple RejectionTyp. 55dB (f=1kHz)
- Low Dropout VoltageTyp. 0.2V (I_{OUT}=60mA)
- Low Temperature-Drift Coefficient of Output Voltage.....Typ. \pm 100ppm/ $^{\circ}$ C
- Excellent Line Regulation.....Typ. 0.05%/V
- Output VoltageStepwise setting with a step of 0.1V in the range of 2.0V to 6.0V is possible (refer to Selection Guide).
- Built-in Short Current Limit Circuit.....Typ. 50mA
- Small PackageSOT-23-5 (Mini-mold), SOT89

APPLICATIONS

- Power source for battery-powered equipment.
- Power source for cellular phones, cameras, VCRs, camcorders, hand-held audio instruments and hand-held communication equipment.
- Power source for domestic appliances.

BLOCK DIAGRAMS

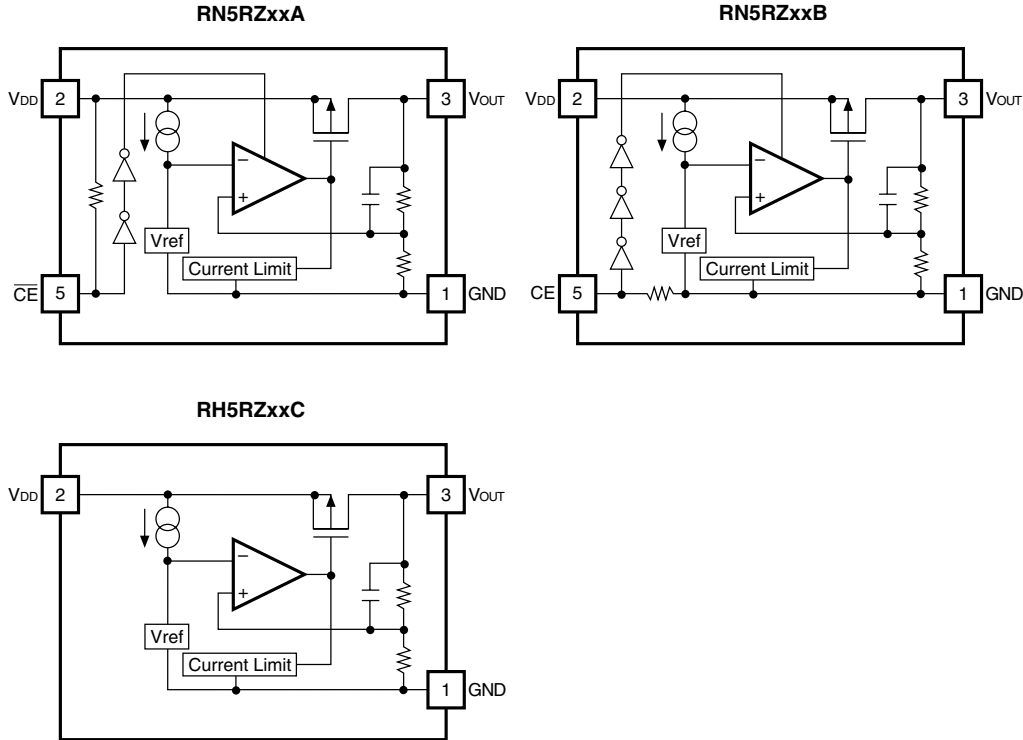

SELECTION GUIDE

The output voltage, the active type of the chip enable circuit, the packing type, and the taping type for the ICs can be selected at the user's request.

These selections can be made by designating the part number as shown below:

Rx5RZxxxx-xx ← Part Number
 ↑ ↑↑↑↑ ↑
 a b cd e

Code	Contents
a	Package type: N : SOT23-5 H : SOT89
b	Setting Output Voltage (V _{OUT}) : Stepwise setting with a step of 0.1V in the range of 2.0V to 6.0V is possible.
c	Designation of Active Type of The Chip Enable Circuit : A : "L" active type B : "H" active type C : no CE pin
d	Designation of Packing Type : A : Taping C : Antistatic bag (for Samples only)
e	Designation of Taping Type : Ex. TR, TL (refer to Taping Specifications ; TR type is the standard direction.)

For example, the product with Output Voltage of 5.0V, Specified Polarity of Chip Enable is "H" active and Taping Type TR is designated by Part Number RN5RZ50BA-TR.

PIN CONFIGURATION

• SOT-23-5

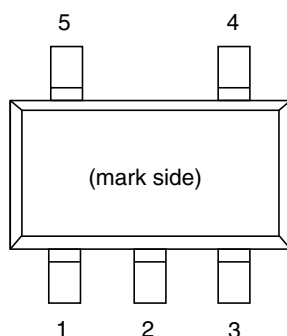

• SOT89

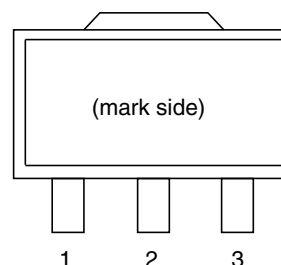

PIN DESCRIPTION

Pin No.	Symbol	Description
1	GND	Ground Pin
2	VDD	Input Pin
3	VOUT	Output Pin
4	NC	No Connection
5	CE or $\overline{\text{CE}}$	Chip Enable Pin

ABSOLUTE MAXIMUM RATINGS

Symbol	Item	Ratings	Unit
V _{IN}	Input Voltage	9	V
V _{CE}	Input Voltage (CE or $\overline{\text{CE}}$ Pin)	-0.3 to V _{IN} +0.3	V
V _{OUT}	Output Voltage	-0.3 to V _{IN} +0.3	V
I _{OUT}	Output Current	200	mA
P _D	Power Dissipation	250 (SOT23-5) 500 (SOT89)	mW
T _{opt}	Operating Temperature	-40 to +85	°C
T _{stg}	Storage Temperature	-55 to +125	°C

ABSOLUTE MAXIMUM RATINGS

Absolute Maximum ratings are threshold limit values that must not be exceeded even for an instant under any conditions. Moreover, such values for any two items must not be reached simultaneously. Operation above these absolute maximum ratings may cause degradation or permanent damage to the device. These are stress ratings only and do not necessarily imply functional operation below these limits.

ELECTRICAL CHARACTERISTICS

• RN5RZxxA Series

T_{opt}=25°C

Symbol	Item	Conditions	Min.	Typ.	Max.	Unit
V _{OUT}	Output Voltage	V _{IN} =V _{OUT} +1V, I _{OUT} =30mA	×0.98		×1.02	V
I _{OUT}	Output Current	V _{IN} =V _{OUT} +1V When V _{OUT} =V _{OUT} -0.1V	100			mA
$\frac{\Delta V_{OUT}}{\Delta I_{OUT}}$	Load Regulation	V _{IN} =V _{OUT} +1V 1mA≤I _{OUT} ≤80mA		20	40	mV
V _{DIF}	Dropout Voltage	I _{OUT} =60mA		0.2	0.3	V
I _{SS}	Supply Current	V _{IN} =V _{OUT} +1V		20	40	μA
I _{standby}	Supply Current (Standby)	V _{IN} =V _{CE} =V _{OUT} +1V		0.1	1.0	μA
$\frac{\Delta V_{OUT}}{\Delta V_{IN}}$	Line Regulation	I _{OUT} =30mA V _{OUT} +0.5V≤V _{IN} ≤8.0V		0.05	0.20	%/V
RR	Ripple Rejection	f=1kHz, Ripple 0.5V _{rms} V _{IN} =V _{OUT} +1V		55		dB
V _{IN}	Input Voltage				8	V
$\frac{\Delta V_{OUT}}{\Delta T_{opt}}$	Output Voltage Temperature Coefficient	I _{OUT} =30mA -40°C≤T _{opt} ≤85°C		±100		ppm/°C
I _{lim}	Short Current Limit	V _{OUT} =0V		50		mA
R _{PU}	\overline{CE} Pull-up Resistance		2.5	5.0	10.0	MΩ
V _{CEH}	\overline{CE} Input Voltage "H"		1.5			V
V _{CEL}	\overline{CE} Input Voltage "L"		0.00		0.25	V

• RN5RZxxB Series

T_{opt}=25°C

Symbol	Item	Conditions	Min.	Typ.	Max.	Unit
V _{OUT}	Output Voltage	V _{IN} =V _{OUT} +1V, I _{OUT} =30mA	×0.98		×1.02	V
I _{OUT}	Output Current	V _{IN} =V _{OUT} +1V When V _{OUT} =V _{OUT} -0.1V	100			mA
$\frac{\Delta V_{OUT}}{\Delta I_{OUT}}$	Load Regulation	V _{IN} =V _{OUT} +1V 1mA≤I _{OUT} ≤80mA		20	40	mV
V _{DIF}	Dropout Voltage	I _{OUT} =60mA		0.2	0.3	V
I _{SS}	Supply Current	V _{IN} =V _{OUT} +1V		20	40	μA
I _{standby}	Supply Current (Standby)	V _{IN} =V _{OUT} +1V, V _{CE} =GND		0.1	1.0	μA
$\frac{\Delta V_{OUT}}{\Delta V_{IN}}$	Line Regulation	I _{OUT} =30mA V _{OUT} +0.5V≤V _{IN} ≤8.0V		0.05	0.20	%/V
RR	Ripple Rejection	f=1kHz, Ripple 0.5V _{rms} V _{IN} =V _{OUT} +1V		55		dB
V _{IN}	Input Voltage				8	V
$\frac{\Delta V_{OUT}}{\Delta T_{opt}}$	Output Voltage Temperature Coefficient	I _{OUT} =30mA -40°C≤T _{opt} ≤85°C		±100		ppm/°C
I _{lim}	Short Current Limit	V _{OUT} =0V		50		mA
R _{PU}	CE Pull-down Resistance		2.5	5.0	10.0	MΩ
V _{CEH}	CE Input Voltage “H”		1.5			V
V _{CEL}	CE Input Voltage “L”		0.00		0.25	V

• RH5RZxxC Series

T_{opt}=25°C

Symbol	Item	Conditions	Min.	Typ.	Max.	Unit
V _{OUT}	Output Voltage	V _{IN} =V _{OUT} +1V, I _{OUT} =30mA	×0.98		×1.02	V
I _{OUT}	Output Current	V _{IN} =V _{OUT} +1V	100			mA
$\frac{\Delta V_{OUT}}{\Delta I_{OUT}}$	Load Regulation	V _{IN} =V _{OUT} +1V 1mA≤I _{OUT} ≤80mA		20	40	mV
V _{DIF}	Dropout Voltage	I _{OUT} =60mA		0.2	0.3	V
I _{SS}	Supply Current	V _{IN} =V _{OUT} +1V		20	40	μA
$\frac{\Delta V_{OUT}}{\Delta V_{IN}}$	Line Regulation	I _{OUT} =30mA V _{OUT} +0.5V≤V _{IN} ≤8.0V		0.05	0.20	%/V
RR	Ripple Rejection	f=1kHz, Ripple 0.5V _{rms} V _{IN} =V _{OUT} +1V		55		dB
V _{IN}	Input Voltage				8	V
$\frac{\Delta V_{OUT}}{\Delta T_{opt}}$	Output Voltage Temperature Coefficient	I _{OUT} =30mA -40°C≤T _{opt} ≤85°C		±100		ppm/°C
I _{lim}	Short Current Limit	V _{OUT} =0V		50		mA

OPERATION

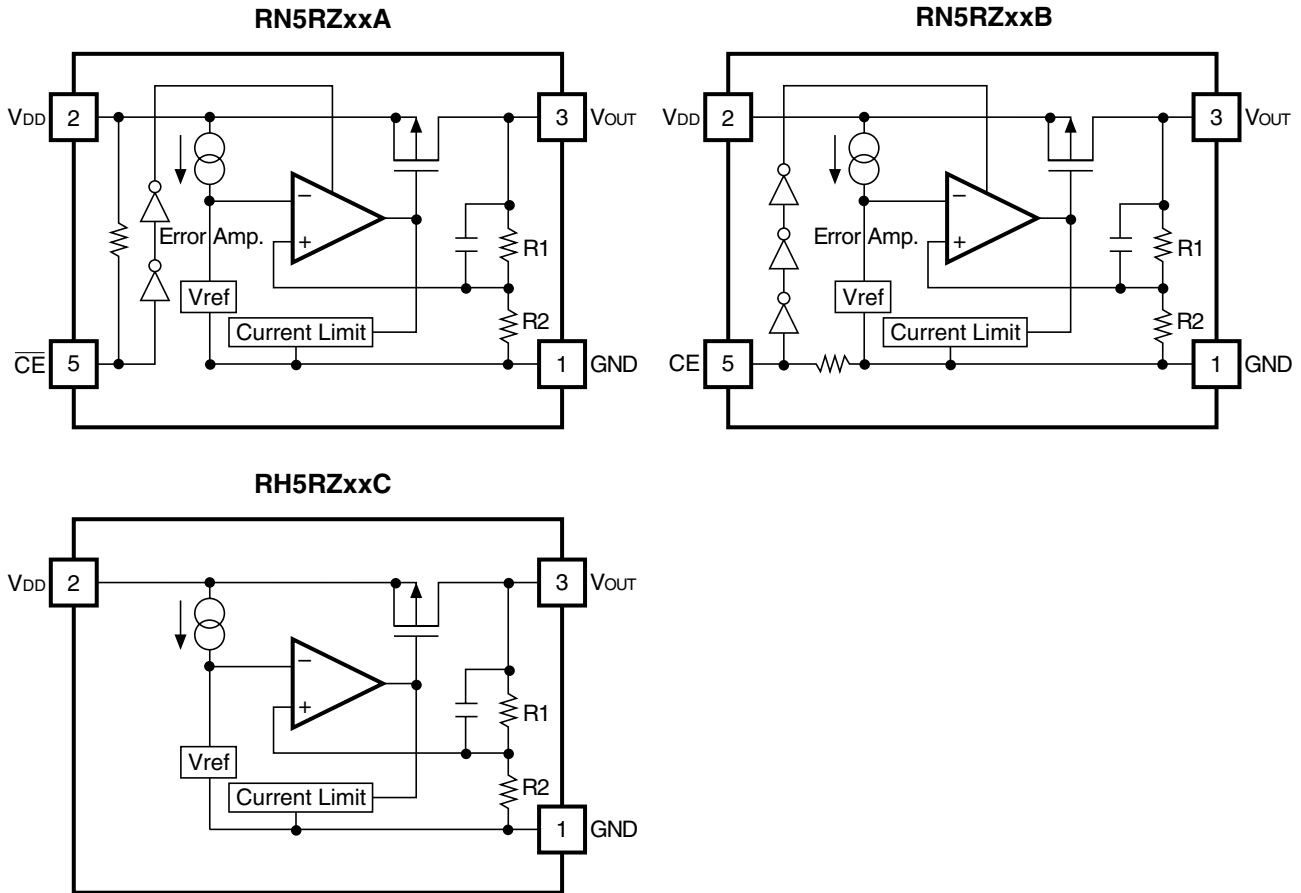

In these ICs, the output voltage V_{OUT} is detected by feed-back registers R₁, R₂, and the detected output voltage is compared with a reference voltage by an error amplifier, so that a constant voltage is output.

A current limit circuit working for short protection and a chip enable circuit for standby function are included.

TEST CIRCUITS

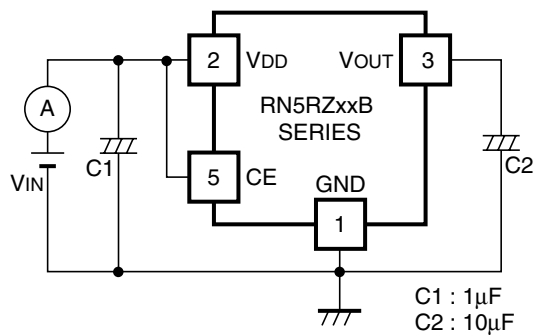
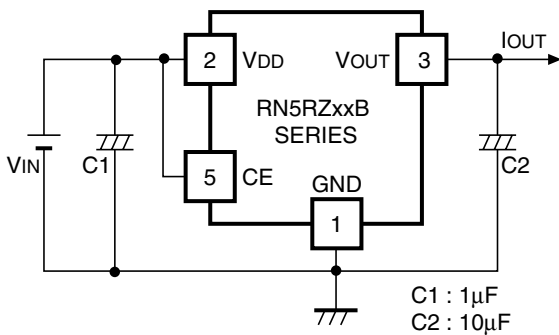

Fig.1 Standard Test Circuit

Fig.2 Supply Current Test Circuit

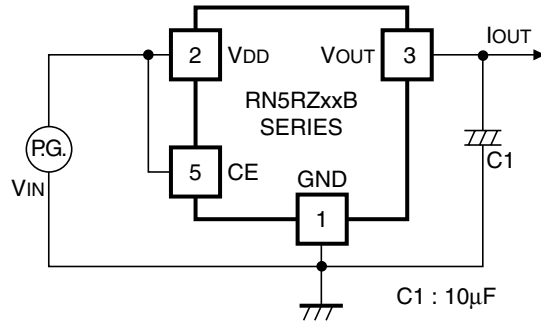

Fig.3 Line Transient Response Test Circuit

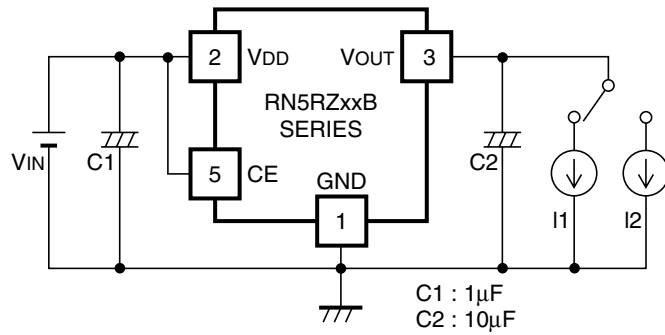

Fig.4 Load Transient Response Test Circuit

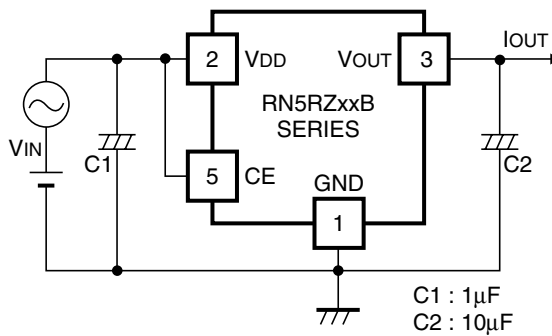
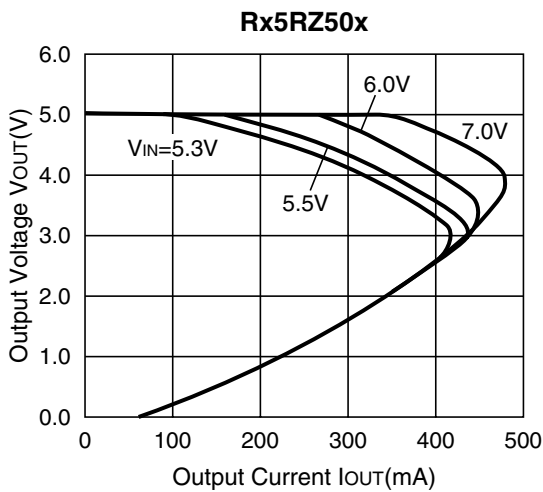
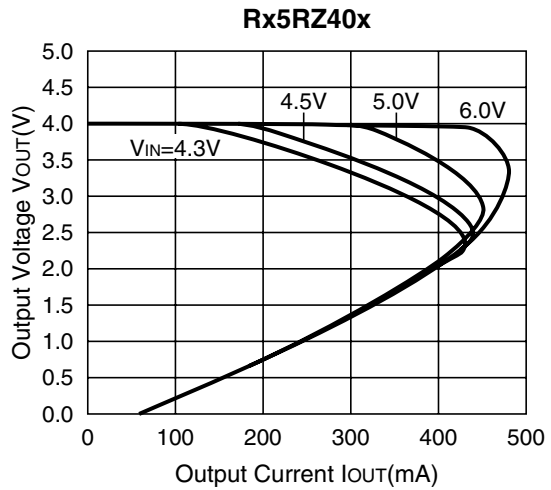
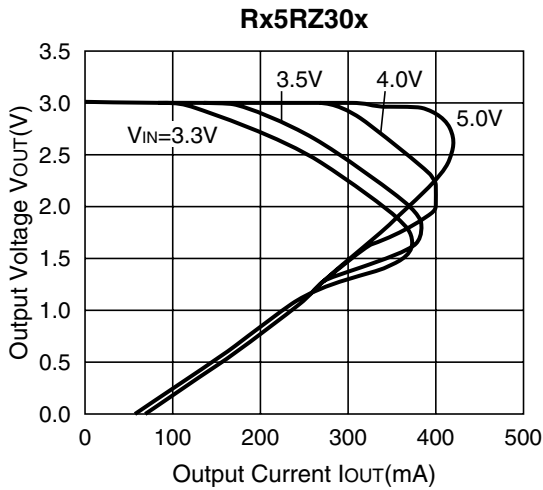

Fig.5 Ripple Rejection Test Circuit

TYPICAL CHARACTERISTICS

1) Output Voltage vs. Output Current



2) Output Voltage vs. Input Voltage

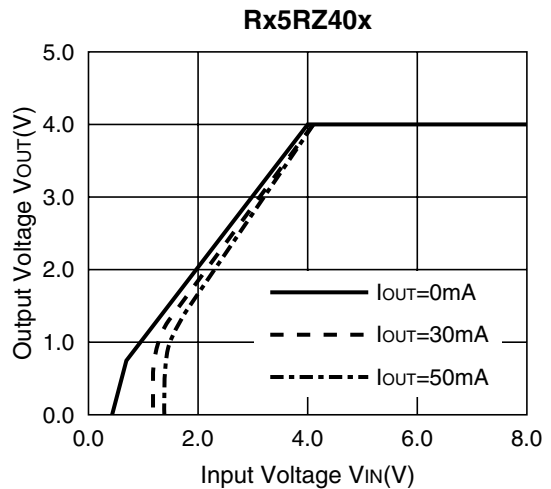
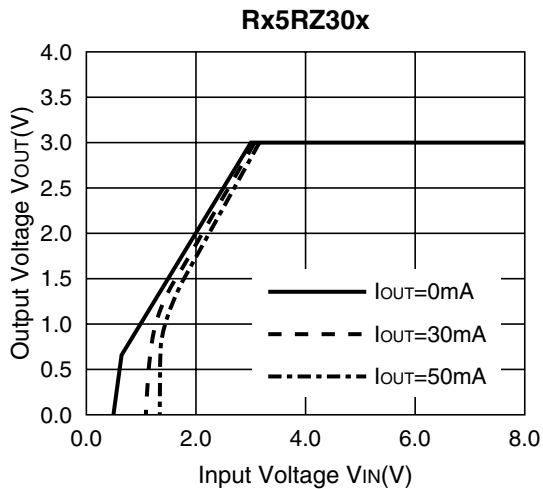

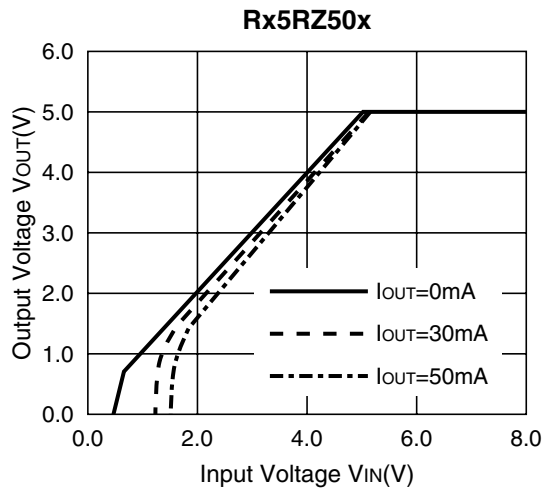

3) Dropout Voltage vs. Output Current

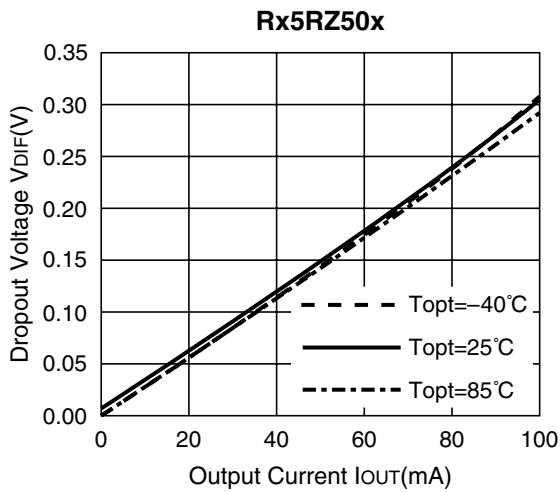
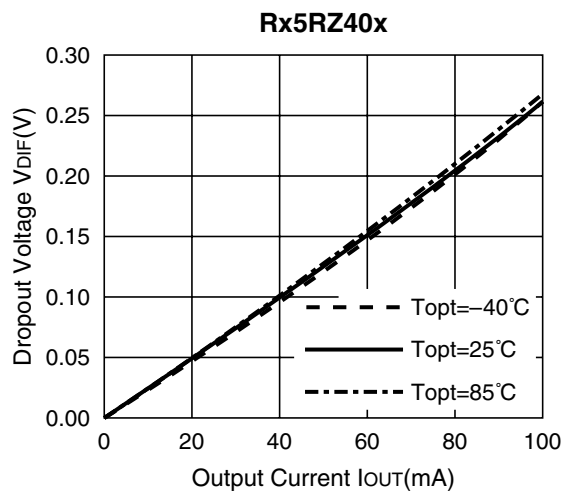
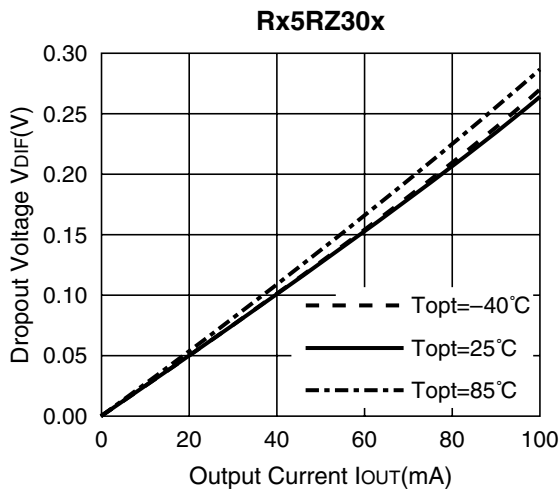

4) Output Voltage vs. Temperature

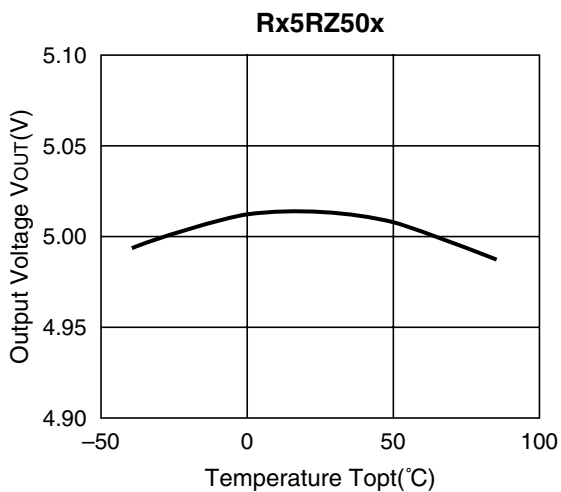
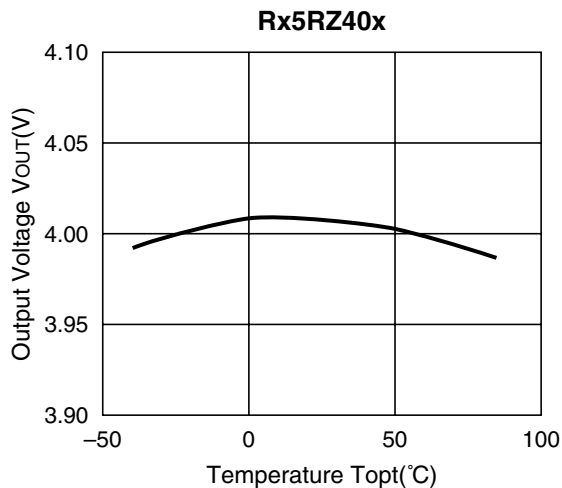
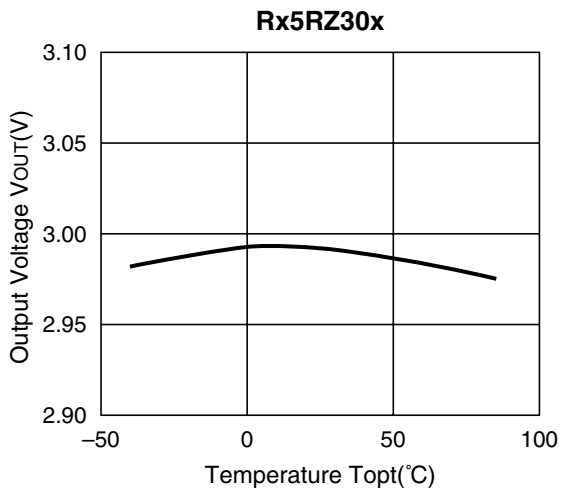

5) Supply Current vs. Input Voltage

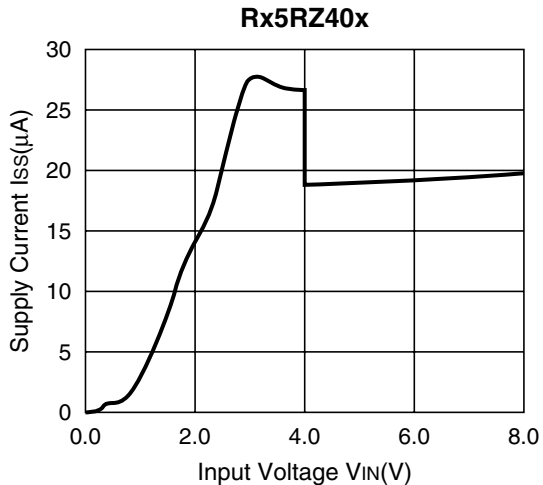
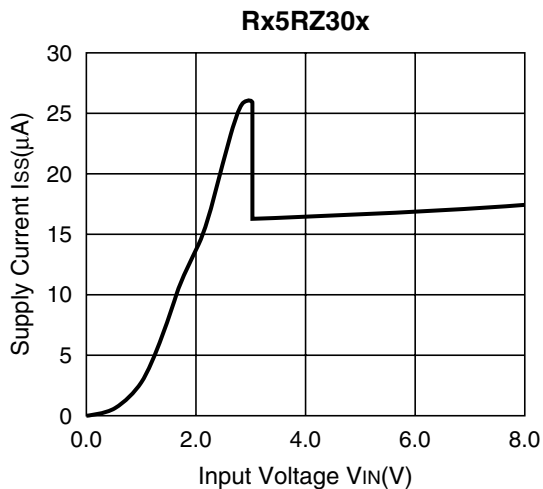

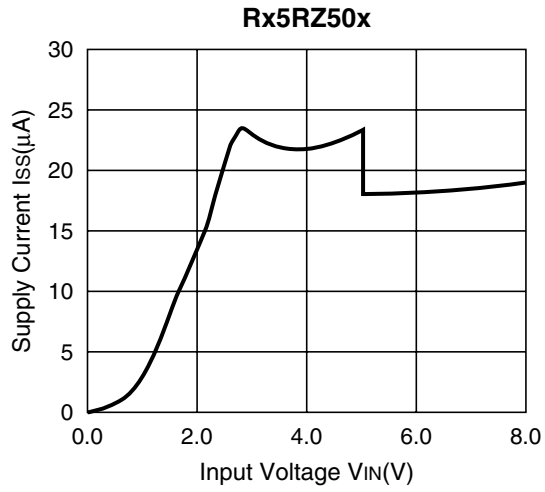

6) Supply Current vs. Temperature

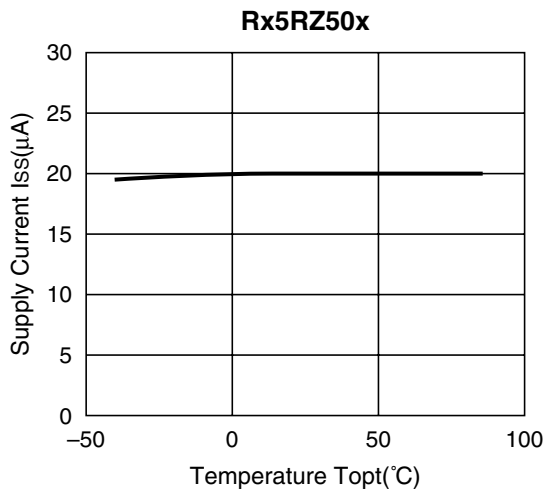
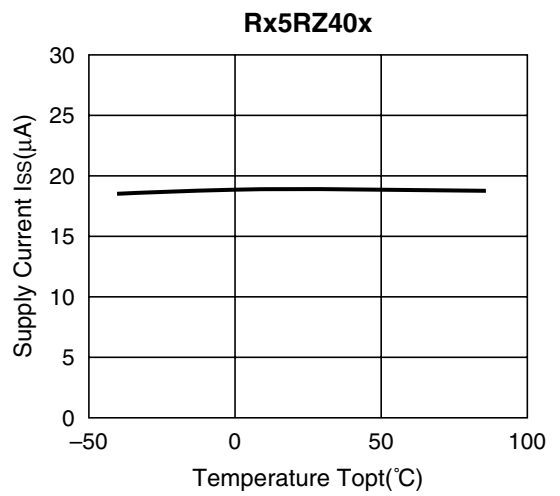
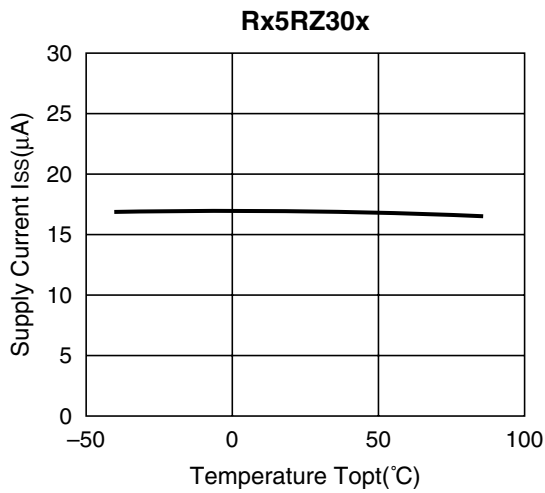

7) Dropout Voltage vs. Set Output Voltage

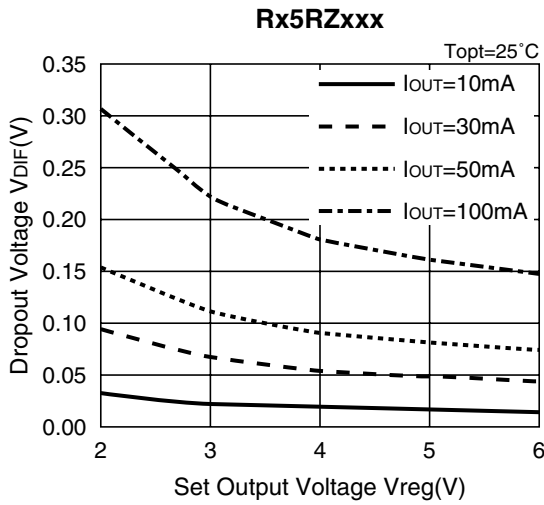

8) Ripple Rejection vs. Frequency

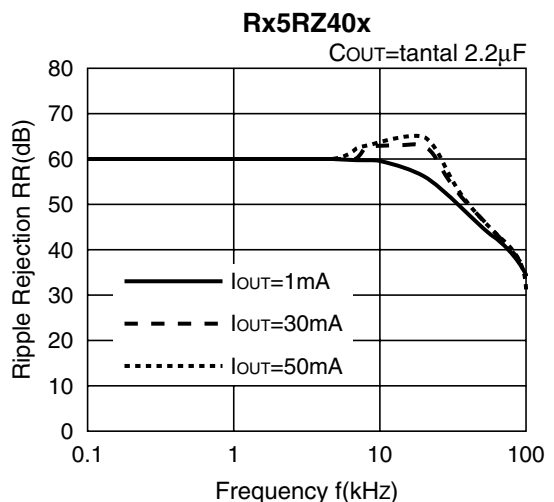
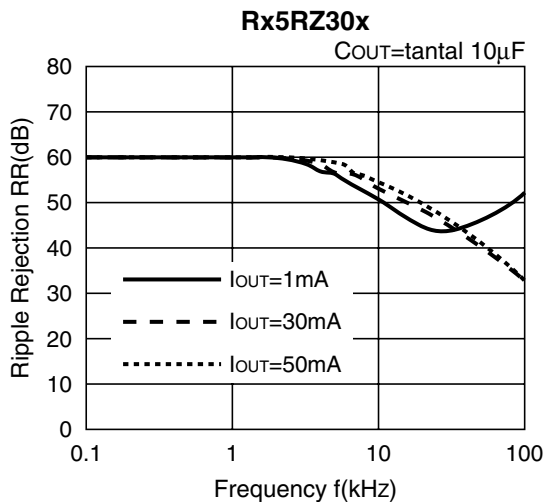
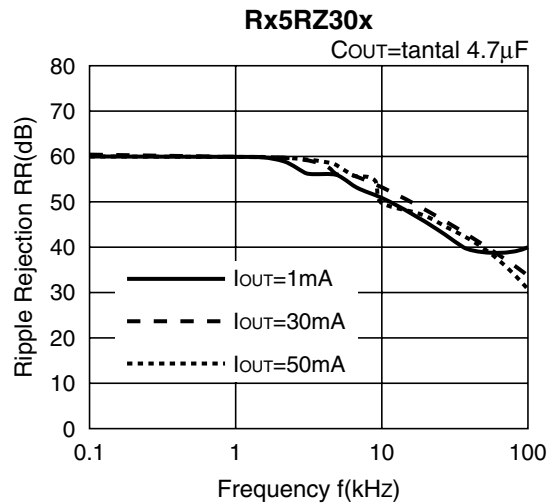
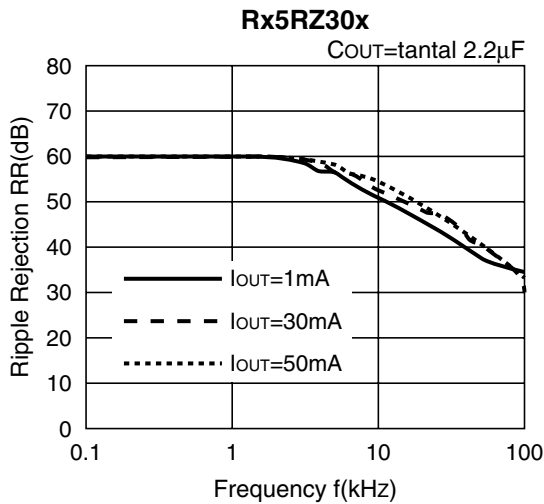

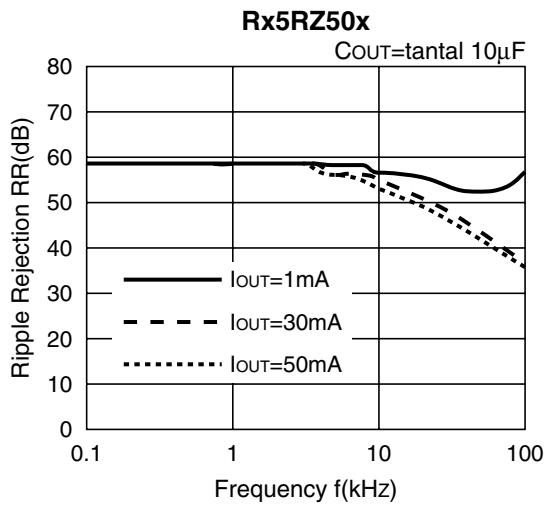
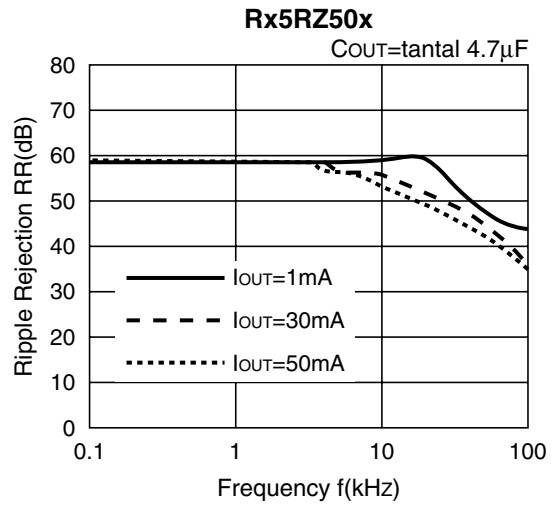
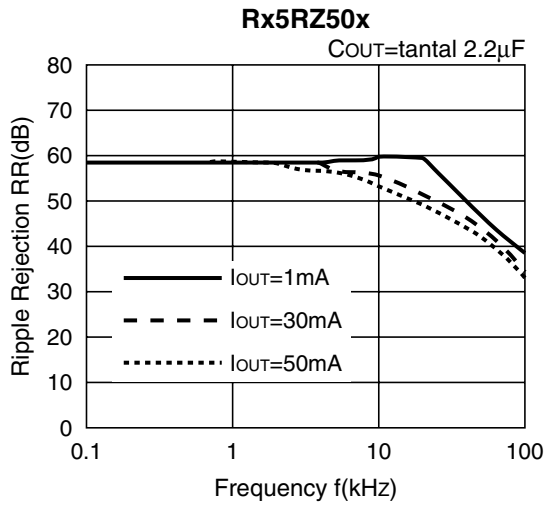
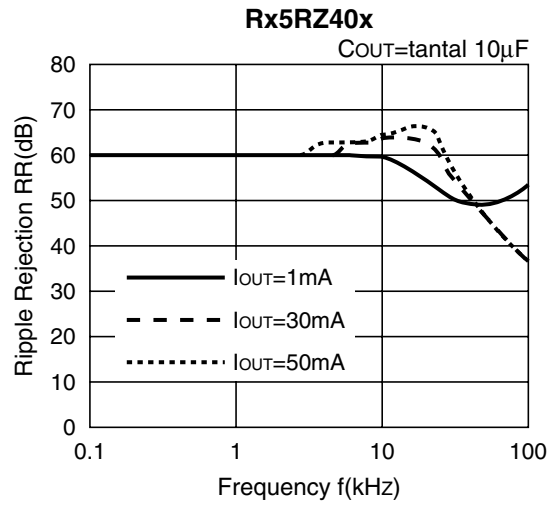
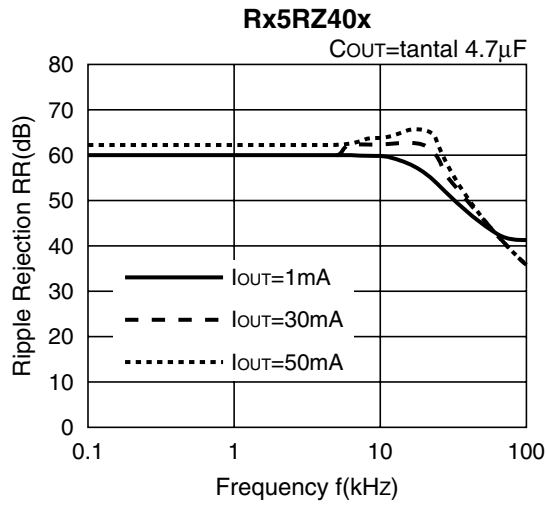

9) Ripple Rejection vs. Input Voltage (DC bias)

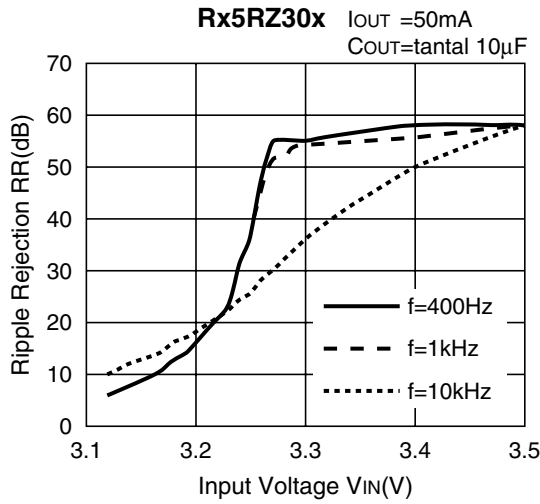
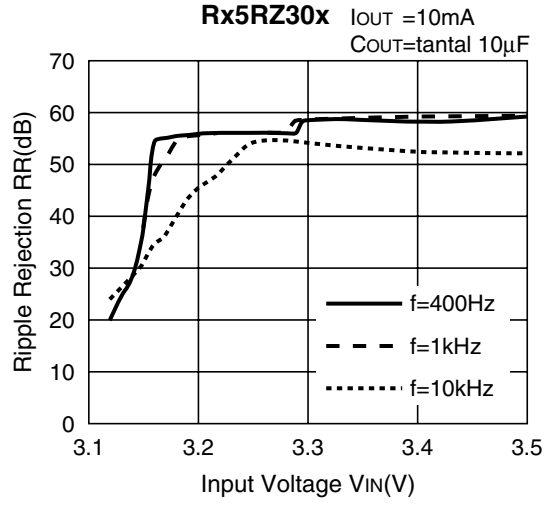
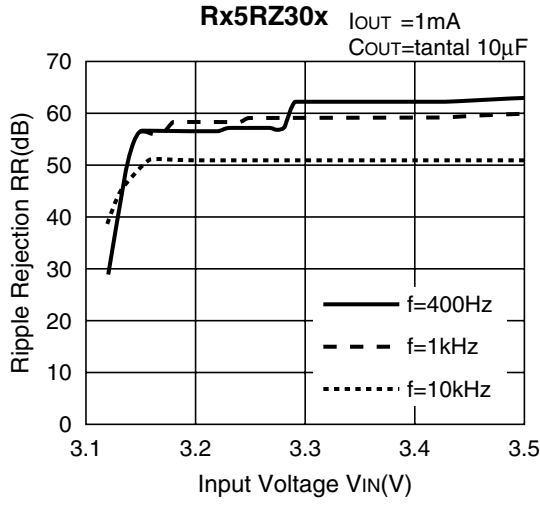

10) Line Transient Response

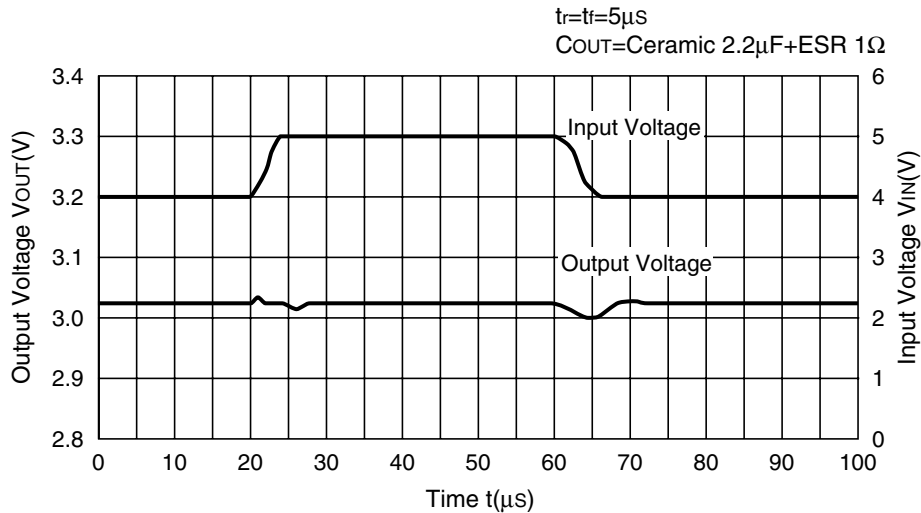

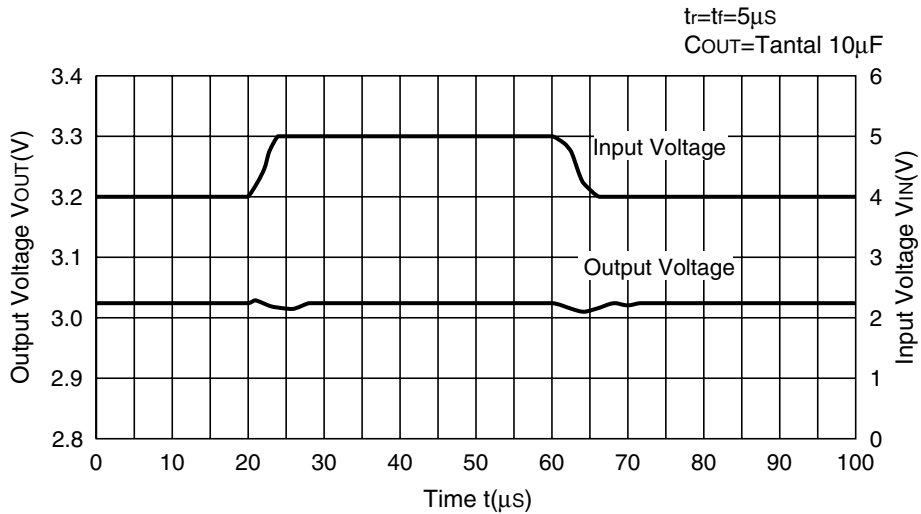
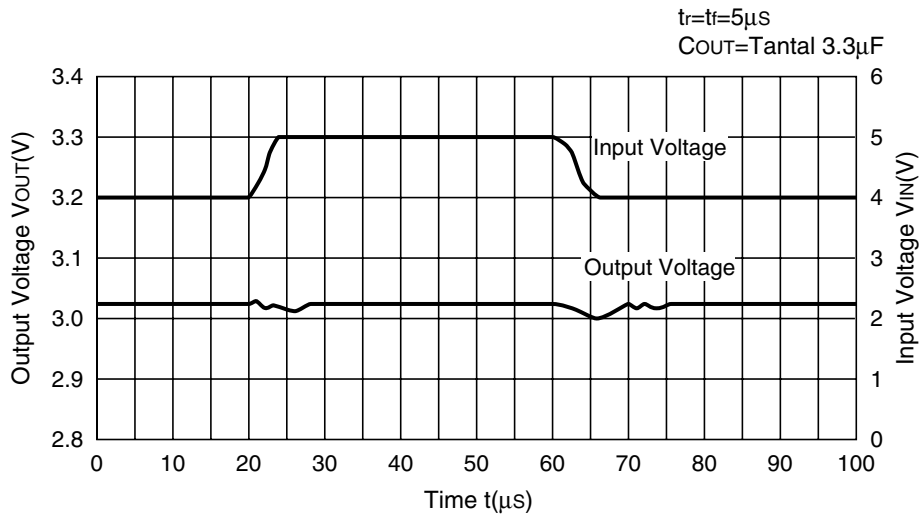

11) Load Transient Response

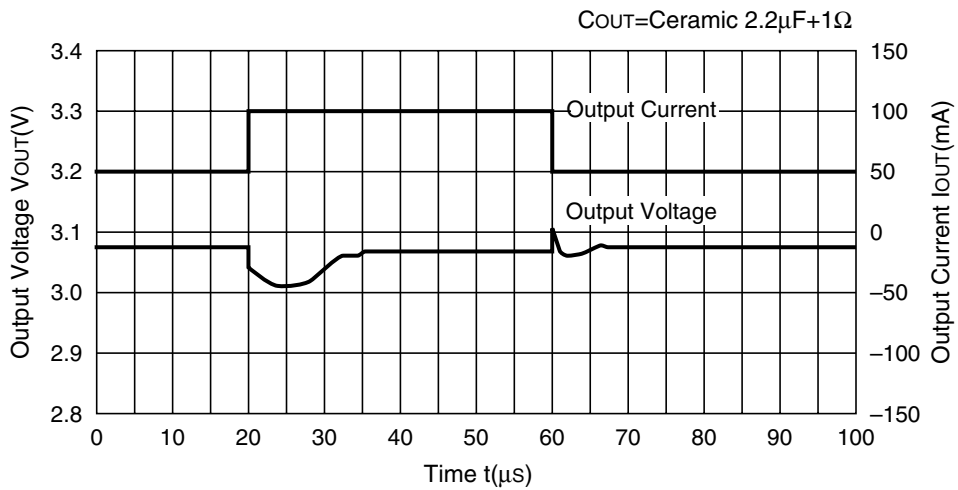

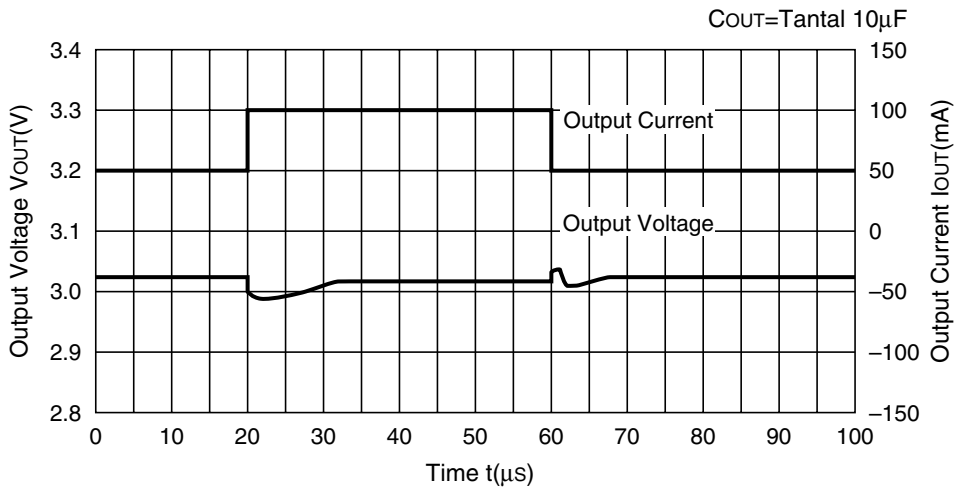
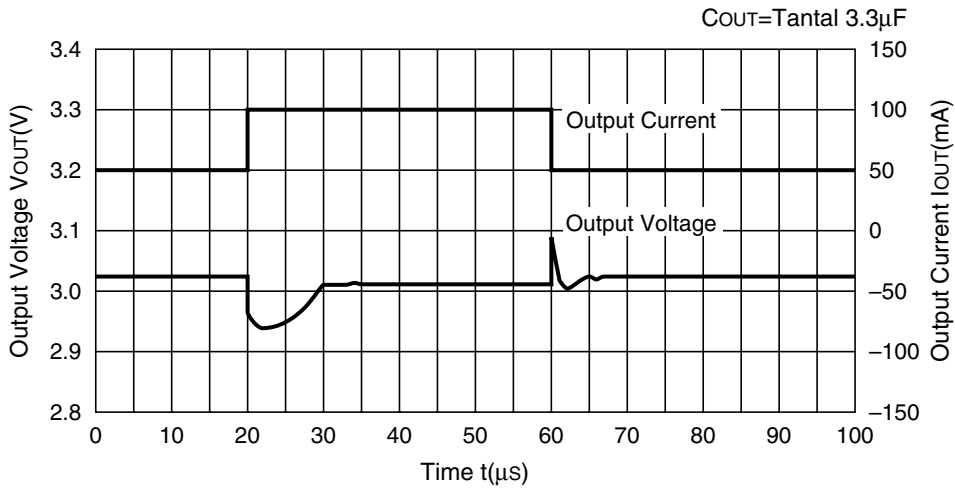
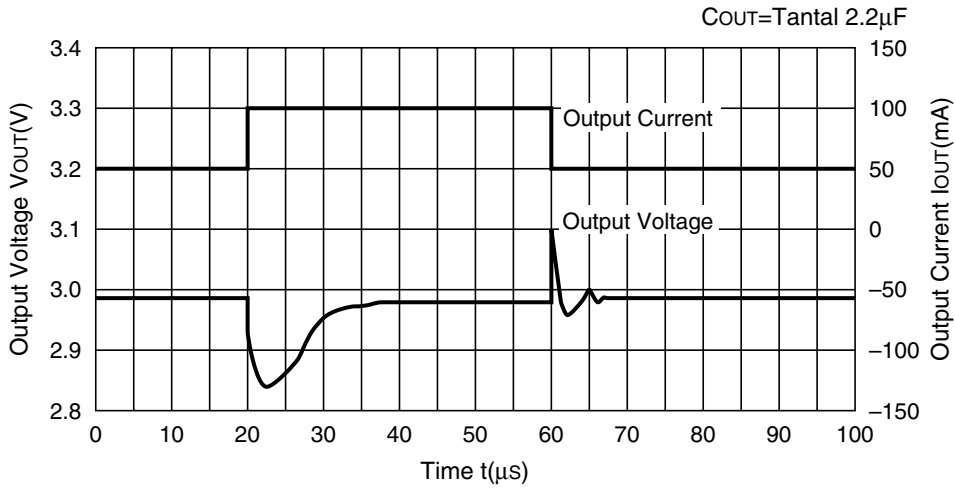

FOR STABLE OPERATION

• Countermeasure for Noise

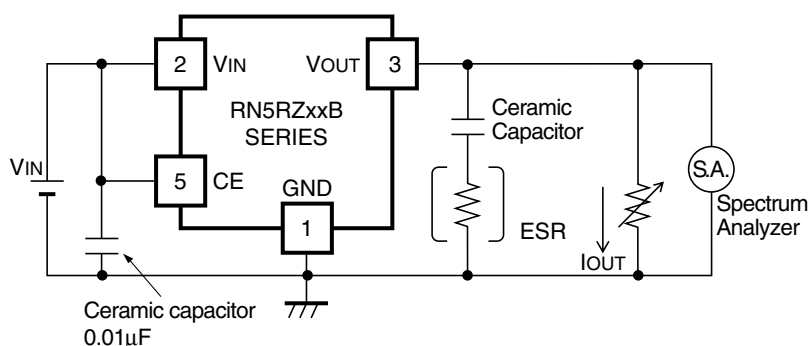

Measuring circuit for white noise ; RN5RZ30B

The relationship between output current (I_{OUT}) and Equivalent Series Resistance (ESR) in the output capacitor is described in the graphs below. The conditions when the noise level is under $40\mu\text{V}$ (Avg.) are indicated by the hatched area in the graph.

[Measuring conditions]

Frequency band : 0Hz to 1MHz

Temperature : 25°C

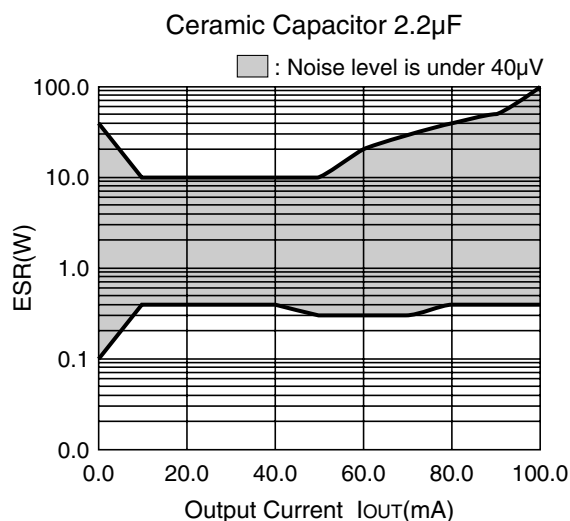
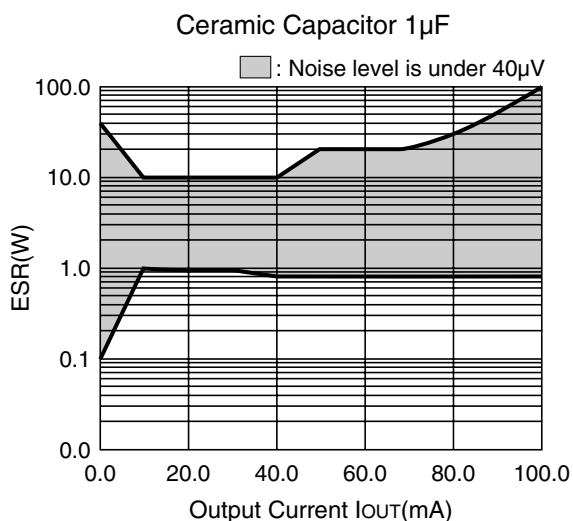

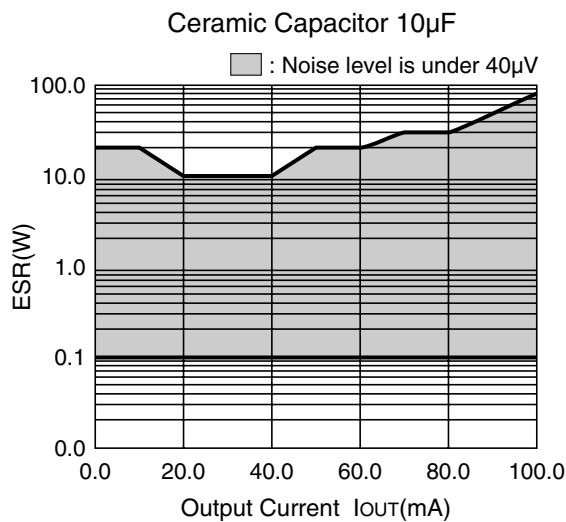
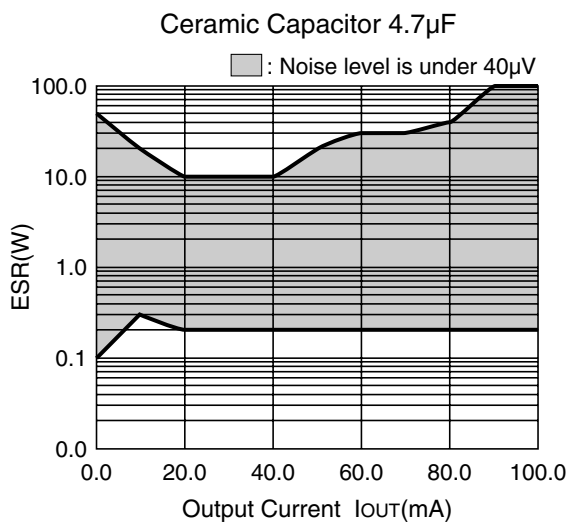

APPLICATION HINTS

When using these ICs, be sure to take care regarding the following points :

- In these ICs, phase compensation is made for securing stable operation even when the load current is varied. For this purpose, be sure to use a capacitor C_{OUT} with good frequency characteristics and ESR in the range described above.
- Make V_{DD} and GND lines sufficient. If their impedance is high, the noise picked up or unstable operation may result.
- Connect the capacitor with a capacitance of about 1 μ F between V_{DD} and GND with wiring as short as possible.
- Set external components as close as possible to the ICs and make wiring as short as possible.

- SOT-23-5 (SC-74A)

Unit: mm

PACKAGE DIMENSIONS

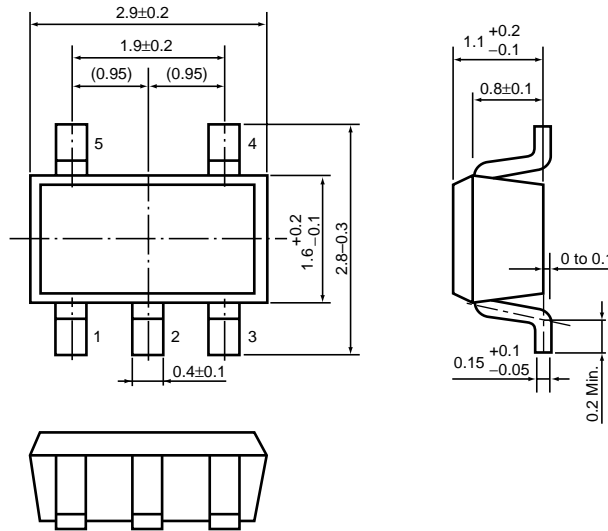

TAPING SPECIFICATION

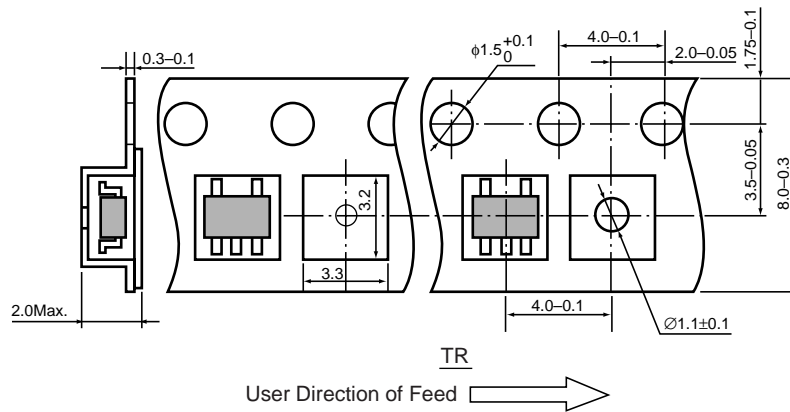

TAPING REEL DIMENSIONS REUSE REEL (EIAJ-RRM-08Bc)

(1reel=3000pcs)

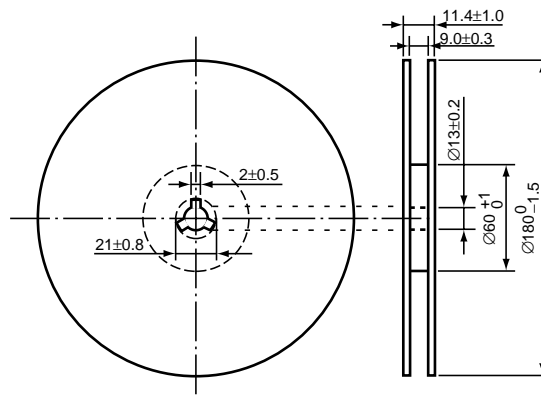

POWER DISSIPATION (SOT-23-5)

This specification is at mounted on board. Power Dissipation (P_D) depends on conditions of mounting on board.

This specification is based on the measurement at the condition below:

(Power Dissipation (SOT-23-5) is substitution of SOT-23-6.)

Measurement Conditions

	Standard Land Pattern
Environment	Mounting on Board (Wind velocity=0m/s)
Board Material	Glass cloth epoxy plastic (Double sided)
Board Dimensions	40mm × 40mm × 1.6mm
Copper Ratio	Top side : Approx. 50% , Back side : Approx. 50%
Through-hole	φ0.5mm × 44pcs

Measurement Result

($T_{opt}=25^{\circ}C$, $T_{jmax}=125^{\circ}C$)

	Standard Land Pattern	Free Air
Power Dissipation	420mW	250mW
Thermal Resistance	$\theta_{ja}=(125-25^{\circ}C)/0.42W=238^{\circ}C/W$	400 $^{\circ}C/W$

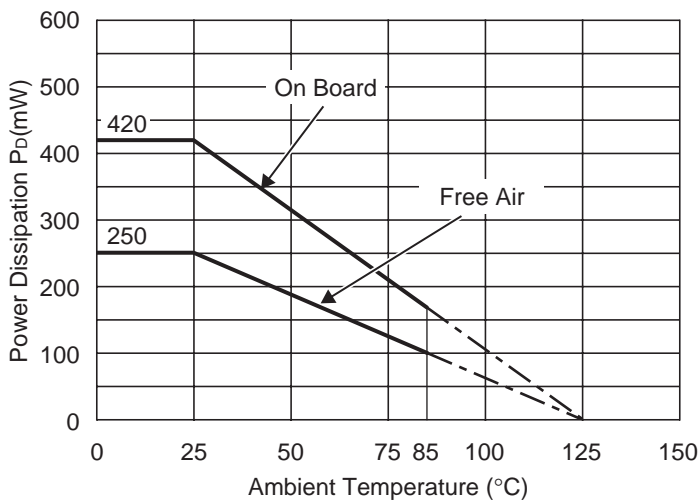

Power Dissipation

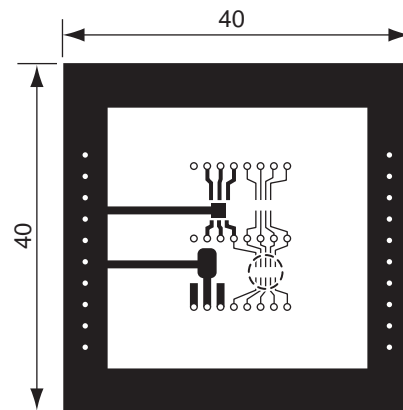

Measurement Board Pattern

○ IC Mount Area Unit : mm

RECOMMENDED LAND PATTERN

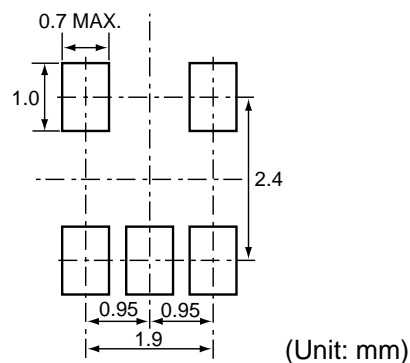

- SOT-89 (SC-62)

Unit: mm

PACKAGE DIMENSIONS

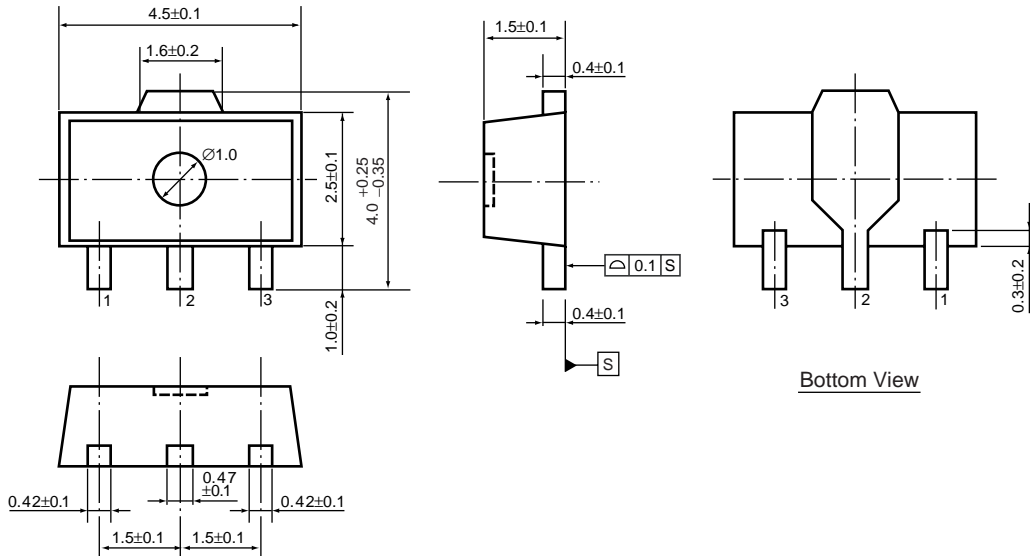

TAPING SPECIFICATION (T1: Standard Type)

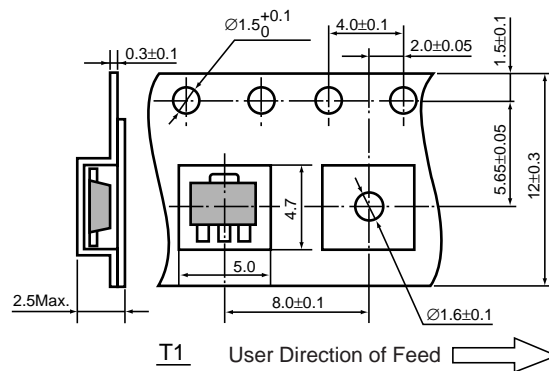

TAPING REEL DIMENSIONS

(1reel=1000pcs)

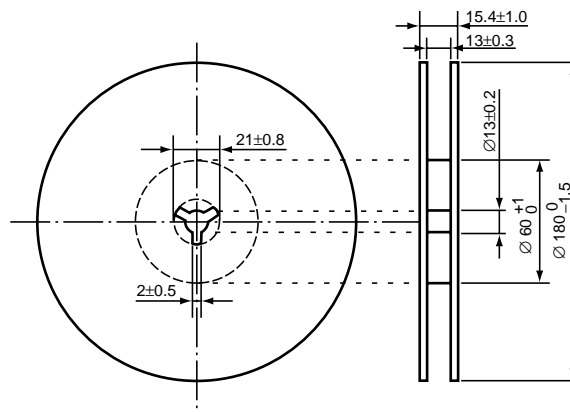

POWER DISSIPATION (SOT-89)

This specification is at mounted on board. Power Dissipation (P_D) depends on conditions of mounting on board. This specification is based on the measurement at the condition below:

Measurement Conditions

	Standard Land Pattern
Environment	Mounting on Board (Wind velocity=0m/s)
Board Material	Glass cloth epoxy plastic (Double sided)
Board Dimensions	50mm × 50mm × 1.6mm
Copper Ratio	Top side : Approx. 10% , Back side : Approx. 100%
Through-hole	-

Measurement Result

($T_{opt}=25^{\circ}C, T_{jmax}=125^{\circ}C$)

	Standard Land Pattern	Free Air
Power Dissipation	900mW	500mW
Thermal Resistance	$\theta_{ja}=(125-25^{\circ}C)/0.9W=111^{\circ}C/W$	200 $^{\circ}C/W$

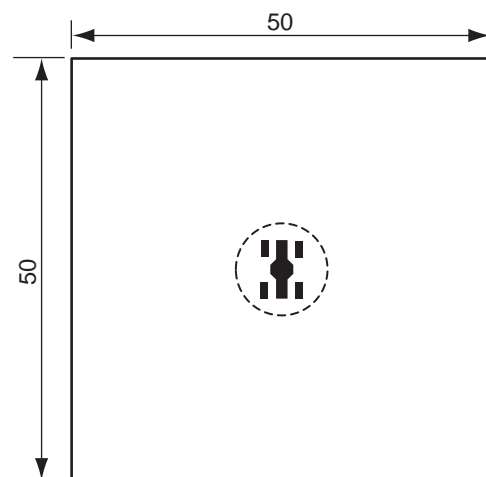
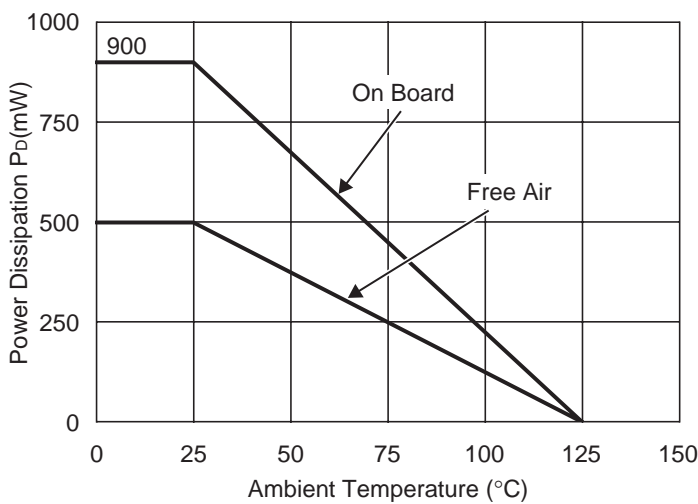

Measurement Board Pattern

○ IC Mount Area (Unit : mm)

RECOMMENDED LAND PATTERN (SOT-89)

