



DEVICES CORPORATION

# LF43168

## Dual 8-Tap FIR Filter

### FEATURES

- ❑ 66 MHz Data and Computation Rate
- ❑ Two Independent 8-Tap or Single 16-Tap FIR Filters
- ❑ 10-bit Data and Coefficient Inputs
- ❑ 32 Programmable Coefficient Sets
- ❑ Supports Interleaved Coefficient Sets
- ❑ User Programmable Decimation up to 16:1
- ❑ Maximum of 256 FIR Filter Taps, 16 x 16 2-D Kernels, or 10 x 20-bit Data and Coefficients
- ❑ Replaces Harris HSP43168
- ❑ DECC SMD No. 5962-97504
- ❑ Available 100% Screened to MIL-STD-883, Class B
- ❑ Package Styles Available:
  - 84-pin Plastic LCC, J-Lead
  - 100-pin Plastic Quad Flatpack
  - 84-pin Ceramic PGA

### DESCRIPTION

The LF43168 is a high-speed dual FIR filter capable of filtering data at real-time video rates. The device contains two FIR filters which may be used as two separate filters or cascaded to form one filter. The input and coefficient data are both 10-bits and can be in unsigned, two's complement, or mixed mode format.

The filter architecture is optimized for symmetric coefficient sets. When symmetric coefficient sets are used, each filter can be configured as an 8-tap FIR filter. If the two filters are cascaded, a 16-tap FIR filter can be implemented. When asymmetric coefficient sets are used, each filter is configured as a 4-tap FIR filter. If both filters are cascaded, an 8-tap filter can

be implemented. The LF43168 can decimate the output data by as much as 16:1. When the device is programmed to decimate, the number of clock cycles available to calculate filter taps increases. When configured for 16:1 decimation, each filter can be configured as a 128-tap FIR filter (if symmetric coefficient sets are used). By cascading these two filters, the device can be configured as a 256-tap FIR filter.

There is on-chip storage for 32 different sets of coefficients. Each set consists of eight coefficients. Access to more than one coefficient set facilitates adaptive filtering operations. The 28-bit filter output can be rounded from 8 to 19 bits.

### LF43168 BLOCK DIAGRAM

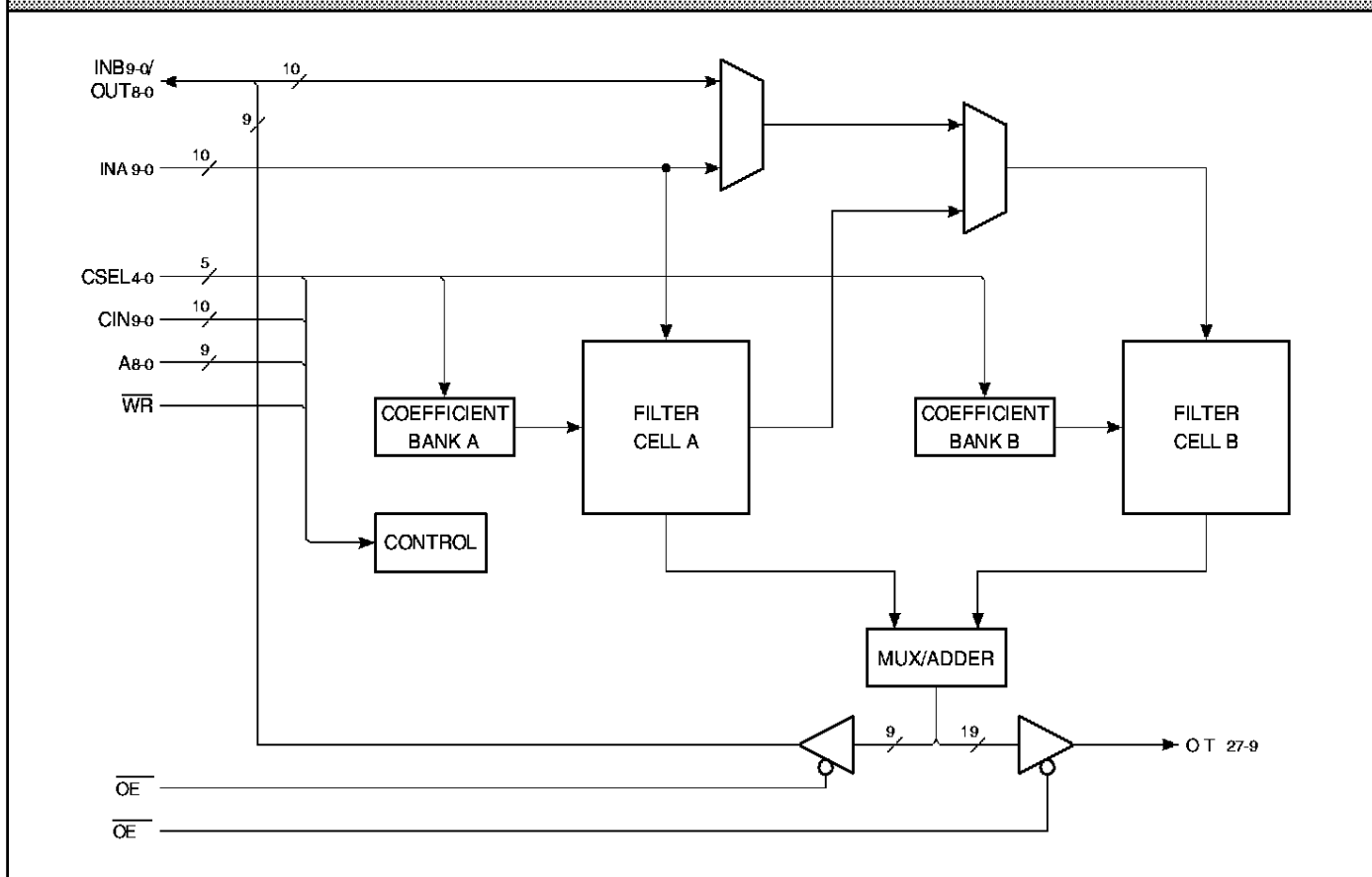

**FIGURE 1. LF43168 FUNCTIONAL BLOCK DIAGRAM**

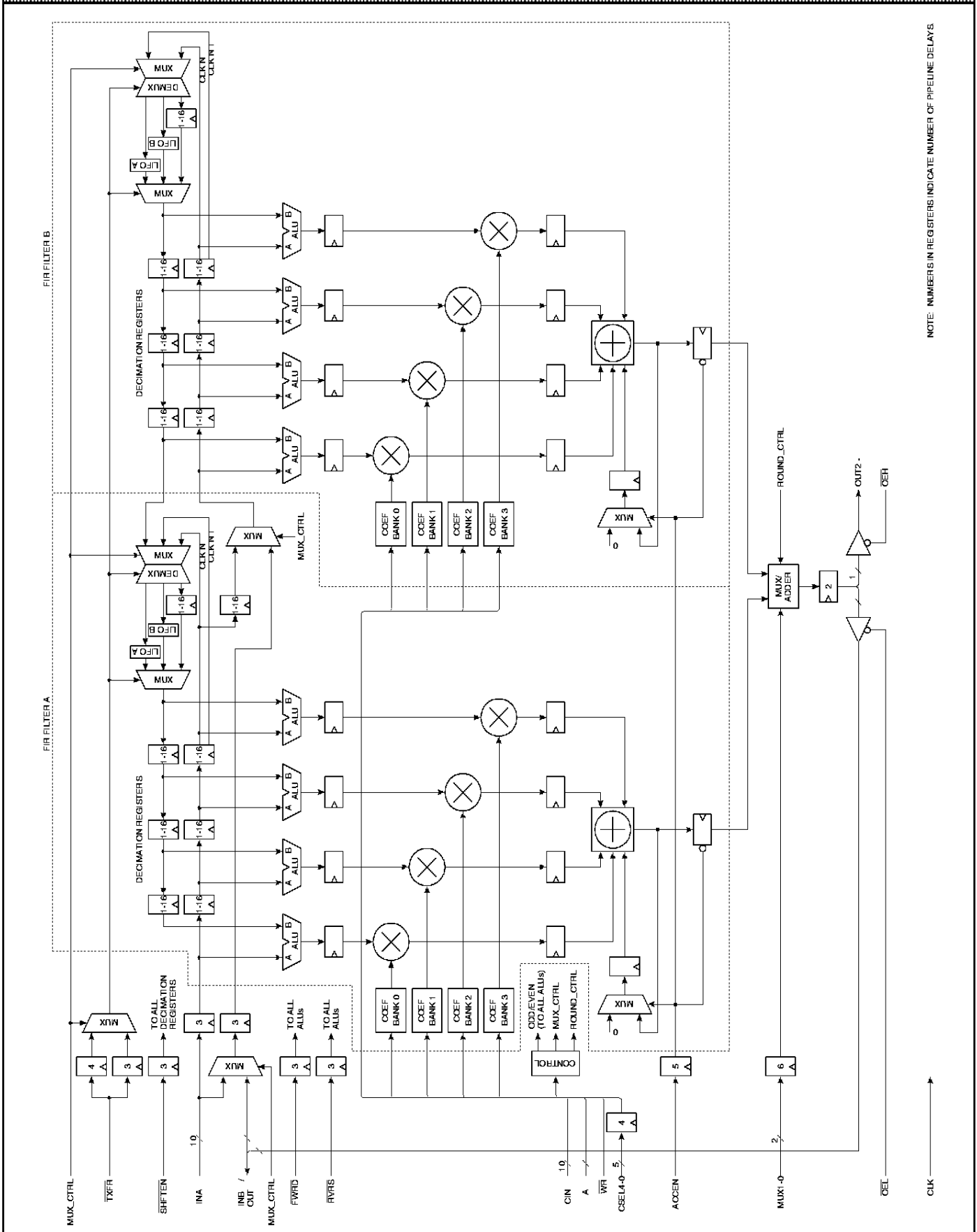

**SIGNAL DEFINITIONS**

**Power**

*VCC and GND*

+5 V power supply. All pins must be connected.

**Clock**

*CLK — Master Clock*

The rising edge of CLK strobes all enabled registers.

**Inputs**

*INA9-0 — Data Input (FIR Filter A)*

INA9-0 is the 10-bit registered data input port for FIR Filter A. INA9-0 can also be used to send data to FIR Filter B. Data is latched on the rising edge of CLK.

*INB9-0 — Data Input (FIR Filter B)*

INB9-0 is the 10-bit registered data input port for FIR Filter B. Data is latched on the rising edge of CLK. INB9-1 is also used as OUT8-0, the nine least significant bits of the data output port (see OUT27-0 section).

*CIN9-0 — Coefficient/Control Data Input*

CIN9-0 is the data input port for the coefficient and control registers. Data is latched on the rising edge of  $\overline{WR}$ .

*A8-0 — Coefficient/Control Address*

A8-0 provides the write address for data on CIN9-0. Data is latched on the falling edge of  $\overline{WR}$ .

$\overline{WR}$  — *Coefficient/Control Write*

The rising edge of  $\overline{WR}$  latches data on CIN9-0 into the coefficient/control register addressed by A8-0.

*CSEL4-0 — Coefficient Select*

CSEL4-0 determines which set of coefficients is sent to the multipliers in both FIR filters. Data is latched on the rising edge of CLK.

**FIGURE 2A. INPUT FORMATS**

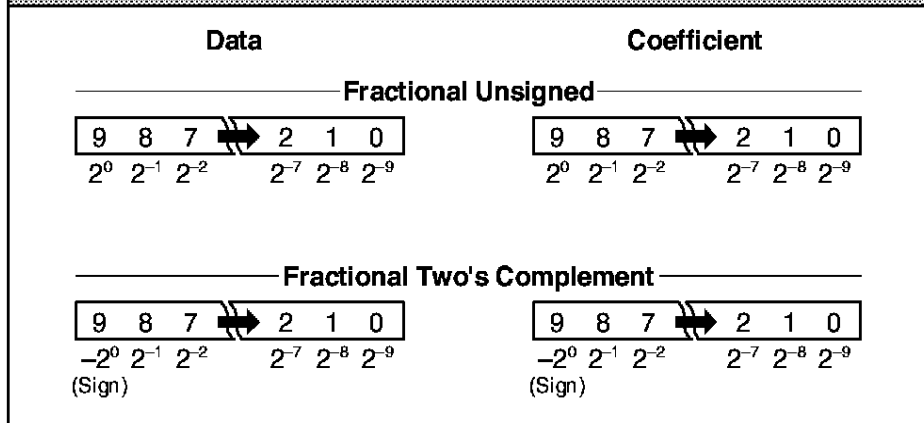

**FIGURE 2B. OUTPUT FORMATS**

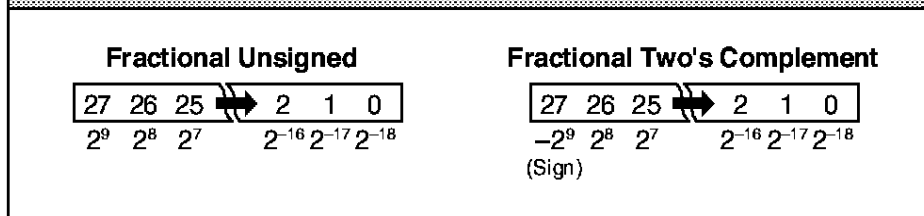

**Outputs**

*OUT27-0 — Data Output*

OUT27-0 is the 28-bit registered data output port. OUT8-0 is also used as INB9-1, the nine most significant bits of the FIR Filter B data input port (see INB9-0 section). If both filters are configured for even-symmetric coefficients, and both input and coefficient data is unsigned, the filter output data will be unsigned. Otherwise, the output data will be in two's complement format.

**Controls**

$\overline{SHFTEN}$  — *Shift Enable*

When  $\overline{SHFTEN}$  is LOW, data on INA9-0 and INB9-0 can be latched into the device and data can be shifted through the decimation registers. When  $\overline{SHFTEN}$  is HIGH, data on INA9-0 and INB9-0 can not be latched into the device and data in the input and decimation registers is held. This signal is latched on the rising edge of CLK.

$\overline{FWRD}$  — *Forward ALU Input*

When  $\overline{FWRD}$  is LOW, data from the forward decimation path is sent to the "A" inputs on the ALUs. When  $\overline{FWRD}$  is HIGH, "0" is sent to the "A" inputs on the ALUs. This signal is latched on the rising edge of CLK.

$\overline{RVRS}$  — *Reverse ALU Input*

When  $\overline{RVRS}$  is LOW, data from the reverse decimation path is sent to the "B" inputs on the ALUs. When  $\overline{RVRS}$  is HIGH, "0" is sent to the "B" inputs on the ALUs. This signal is latched on the rising edge of CLK.

$\overline{TXFR}$  — *LIFO Transfer Control*

When  $\overline{TXFR}$  goes LOW, the LIFO sending data to the reverse decimation path becomes the LIFO receiving data from the forward decimation path, and the LIFO receiving data from the forward decimation path becomes the LIFO sending data to the reverse decimation path. The device must see a HIGH to LOW transition of  $\overline{TXFR}$  in order to switch LIFOs. This signal is latched on the rising edge of CLK.

**ACCEN** — Accumulate Enable

When ACCEN is HIGH, both accumulators are enabled for accumulation and writing to the accumulator output registers is disabled (the registers hold their values). When ACCEN goes LOW, accumulation is halted (by sending zeros to the accumulator feedback inputs) and writing to the accumulator output registers is enabled. This signal is latched on the rising edge of CLK.

**MUX1-0** — Mux/Adder Control

MUX1-0 controls the Mux/Adder as shown in Table 3. Data is latched on the rising edge of CLK.

**OE $\bar{L}$**  — Output Enable Low

When OE $\bar{L}$  is LOW, OUT8-0 is enabled for output and INB9-1 can not be used. When OE $\bar{L}$  is HIGH, OUT8-0 is placed in a high-impedance state and INB9-1 is available for data input.

**OE $\bar{H}$**  — Output Enable High

When OE $\bar{H}$  is LOW, OUT27-9 is enabled for output. When OE $\bar{H}$  is HIGH, OUT27-9 is placed in a high-impedance state.

**FUNCTIONAL DESCRIPTION**

**Control Registers**

There are two control registers which determine how the LF43168 is configured. Tables 1 and 2 show how each register is organized. Data on CIN9-0 is latched into the addressed control register on the rising edge of  $\bar{WR}$ . Address data is input on A8-0. Control Register 0 is written to using address 000H. Control Register 1 is written to using address 001H (Note that addresses 002H to 0FFH are reserved and should not be written to). When a control register is written to, a reset occurs which lasts for 6 CLK cycles from when  $\bar{WR}$  goes HIGH. This reset does not alter any data in the coefficient banks. Control data can be loaded asynchronously to CLK.

**TABLE 1. CONTROL REGISTER 0 — ADDRESS 000H**

<b>BITS</b>	<b>FUNCTION</b>	<b>DESCRIPTION</b>
0-3	Decimation Factor/ Decimation Register Delay Length	0000 = No Decimation, Delay by 1 0001 = Decimate by 2, Delay by 2 0010 = Decimate by 3, Delay by 3 0011 = Decimate by 4, Delay by 4 0100 = Decimate by 5, Delay by 5 0101 = Decimate by 6, Delay by 6 0110 = Decimate by 7, Delay by 7 0111 = Decimate by 8, Delay by 8 1000 = Decimate by 9, Delay by 9 1001 = Decimate by 10, Delay by 10 1010 = Decimate by 11, Delay by 11 1011 = Decimate by 12, Delay by 12 1100 = Decimate by 13, Delay by 13 1101 = Decimate by 14, Delay by 14 1110 = Decimate by 15, Delay by 15 1111 = Decimate by 16, Delay by 16
4	Filter Mode Select	0 = Single Filter Mode 1 = Dual Filter Mode
5	Coefficient Symmetry Select	0 = Even-Symmetric Coefficients 1 = Odd-Symmetric Coefficients
6	FIR Filter A: Odd/Even Taps	0 = Odd Number of Filter Taps 1 = Even Number of Filter Taps
7	FIR Filter B: Odd/Even Taps	0 = Odd Number of Filter Taps 1 = Even Number of Filter Taps
8	FIR Filter B Input Source	0 = Input from INA9-0 1 = Input from INB9-0
9	Interleaved/Non-Interleaved Coefficient Sets	0 = Non-Interleaved Coefficient Sets 1 = Interleaved Coefficient Sets

Bits 0-3 of Control Register 0 control the decimation registers. The decimation factor and decimation register delay length is set using these bits. Bit 4 determines if FIR filters A and B operate separately as two filters or together as one filter. Bit 5 is used to select even or odd-symmetric coefficients. Bits 6 and 7 determine if there are an even or odd number of taps in filters A and B respectively. When the FIR filters are set to operate as two separate filters, bit 8 selects either INA9-0 or INB9-0 as the filter B input source. Bit 9 determines if the coefficient set used is interleaved or non-interleaved (see Interleaved Coefficient Filters section). Most applications use non-interleaved coefficient sets (bit 9 set to "0").

Bits 0 and 1 of Control Register 1 determine the input and coefficient data formats respectively for filter A. Bits 2 and 3 determine the input and coefficient data formats respectively for filter B. Bit 4 is used to enable or disable data reversal on the reverse decimation path. When data reversal is enabled, the data order is reversed before being sent to the reverse decimation path. Bits 5-8 select where rounding will occur on the output data (See Mux/Adder section). Bit 9 enables or disables output rounding.

**Coefficient Banks**

The coefficient banks supply coefficient data to the multipliers in both FIR filters. The LF43168 can store 32 different coefficient sets. A coefficient

TABLE 2. CONTROL REGISTER 1 – ADDRESS 001H		
BITS	FUNCTION	DESCRIPTION
0	FIR Filter A Input Data Format	0 = Unsigned 1 = Two's Complement
1	FIR Filter A Coefficient Format	0 = Unsigned 1 = Two's Complement
2	FIR Filter B Input Data Format	0 = Unsigned 1 = Two's Complement
3	FIR Filter B Coefficient Format	0 = Unsigned 1 = Two's Complement
4	Data Order Reversal Enable	0 = Enabled 1 = Disabled
5–8	Output Round Position	0000 = $2^{-10}$ 0001 = $2^{-9}$ 0010 = $2^{-8}$ 0011 = $2^{-7}$ 0100 = $2^{-6}$ 0101 = $2^{-5}$ 0110 = $2^{-4}$ 0111 = $2^{-3}$ 1000 = $2^{-2}$ 1001 = $2^{-1}$ 1010 = $2^0$ 1011 = $2^1$
9	Output Round Enable	0 = Enabled 1 = Disabled

set consists of 8 coefficient values. Each bank can hold 32 10-bit values. CSEL4-0 is used to select which coefficient set is sent to the filter multipliers. The coefficient set fed to the multipliers may be switched every CLK cycle if desired.

Data on CIN9-0 is latched into the addressed coefficient bank on the rising edge of WR. Address data is input on A8-0 and is decoded as follows: A1-0 determines the bank number ("00", "01", "10", and "11" correspond to banks 0, 1, 2, and 3 respectively), A2 determines which filter ("0" = filter A, "1" = filter B), A7-3 determines which set number the coefficient is in, and A8 must be set to "1". For example, an address of "100111011" will load coefficient set 7 in bank 3 of filter A with data. Coefficient data can be loaded asynchronously to CLK.

**Decimation Registers**

The decimation registers are provided to take advantage of symmetric filter coefficients and to provide data storage for 2-D filtering. The outputs of the registers are fed into the ALUs. Both inputs to an ALU need to be multiplied by the same filter coefficient. By adding or subtracting the two data inputs together before being sent to the filter multiplier, the number of filter taps needed is cut in half. Therefore, an 8-tap FIR filter can be made with only four multipliers. The decimation registers are divided into two groups, the forward and reverse decimation registers. As can be seen in Figure 1, data flows left to right through the forward decimation registers and right to left through the reverse decimation registers. The decimation registers can be pro-

grammed to decimate by 2 to 16 (see Decimation section and Table 1). SHFTEN enables and disables the shifting of data through the decimation registers. When SHFTEN is LOW, data on INA9-0 and INB9-0 can be latched into the device and data can be shifted through the decimation registers. When SHFTEN is HIGH, data on INA9-0 and INB9-0 can not be latched into the device and data in the input and decimation registers is held.

Data feedback circuitry is positioned between the forward and reverse decimation registers. It controls how data from the forward decimation path is fed to the reverse decimation path. The feedback circuitry can either reverse the data order or pass the data unchanged to the reverse decimation path. The mux/demux sends incoming data to one of the LIFOs or the data feedback decimation register. The LIFOs and decimation register feed into a mux. This mux determines if one of the LIFOs or the decimation register sends data to the reverse decimation path.

If the data order needs to be reversed before being sent to the reverse decimation path (for example, when decimating), Data Reversal Mode should be enabled by setting bit 4 of Control Register 1 to "0". When Data Reversal is enabled, data from the forward decimation path is written into one of the LIFOs in the data feedback section while the other LIFO sends data to the reverse decimation path. When TXFR goes LOW, the LIFO sending data to the reverse decimation path becomes the LIFO receiving data from the forward decimation path, and the LIFO receiving data from the forward decimation path becomes the LIFO sending data to the reverse decimation path. The device must see a HIGH to LOW transition of TXFR in order to switch LIFOs. The size of data blocks sent to the reverse decimation path is determined by how often TXFR goes LOW. To send data blocks of size 8 to

the reverse decimation path,  $\overline{\text{TXFR}}$  would have to be set LOW once every 8 CLK cycles. Once a data block size has been established (by asserting  $\overline{\text{TXFR}}$  at the proper frequency), changing the frequency or phase of  $\overline{\text{TXFR}}$  assertion will cause unknown results.

If data should be passed to the reverse decimation path with the order unchanged, Data Reversal Mode should be disabled by setting bit 4 of Control Register 1 to "1" and  $\overline{\text{TXFR}}$  must be set LOW. When Data Reversal is disabled, data from the forward decimation path is written into the data feedback decimation register. The output of this register sends data to the reverse decimation path. The delay length of this register is the same as the forward and reverse decimation register's delay length.

When the LF43168 is configured to operate as a single FIR filter, the forward and reverse decimation paths in filters A and B are cascaded together. The data feedback section in filter B routes data from the forward decimation path to the reverse decimation path. The configuration of filter B's feedback section determines how data is sent to the reverse decimation path. Data going through the feedback section in filter A is sent through the decimation register.

The point at which data from the forward decimation path is sent to the data feedback section is determined by whether the filter is set to have an even or odd number of filter taps. If the filter is set to have an even number of taps, the output of the third forward decimation register is sent to the feedback section. If the filter is set to have an odd number of taps, the data that will be output from the third forward decimation register on the next CLK cycle is sent to the feedback section.

**Decimation**

Decimation by N is accomplished by only reading the LF43168's output once every N clock cycles. For example, to decimate by 10, the output should only be read once every 10 clock cycles. When not decimating, the maximum number of taps possible with a single filter in dual filter mode is eight. When decimating by N, there are N - 1 clock cycles between output readings when the filter output is not read. These extra clock cycles can be used to calculate more filter taps. As the decimation factor increases, the number of available filter taps increases also. When programmed to decimate by N, the number of filter taps for a single filter in dual filter mode increases to 8N.

**Arithmetic Logic Units**

The ALUs can perform the following operations: B + A, B - A, pass A, pass B, and negate A (-A). If  $\overline{\text{FWRD}}$  is LOW, the forward decimation path provides the A inputs to the ALUs. If  $\overline{\text{FWRD}}$  is HIGH, the A inputs are set to "0". If  $\overline{\text{RVRS}}$  is LOW, the reverse decimation path provides the B inputs to the ALUs. If  $\overline{\text{RVRS}}$  is HIGH, the B inputs are set to "0".  $\overline{\text{FWRD}}$ ,  $\overline{\text{RVRS}}$ , and the filter configuration determine which ALU operation is performed. If  $\overline{\text{FWRD}}$  and  $\overline{\text{RVRS}}$  are both set LOW, and the filter is set for even-symmetric coefficients, the ALU will perform the B + A operation. If  $\overline{\text{FWRD}}$  and  $\overline{\text{RVRS}}$  are both set LOW, and the filter is set for odd-symmetric coefficients, the ALU will perform the B - A operation. If  $\overline{\text{FWRD}}$  is set LOW,  $\overline{\text{RVRS}}$  is set HIGH, and the filter is set for even-symmetric coefficients, the ALU will perform the pass A operation. If  $\overline{\text{FWRD}}$  is set LOW,  $\overline{\text{RVRS}}$  is set HIGH, and the filter is set for odd-symmetric coefficients, the ALU will perform the negate A operation. If  $\overline{\text{FWRD}}$  is set HIGH,  $\overline{\text{RVRS}}$  is set LOW, and the filter is set for either even or odd-symmetric coefficients, the ALU will perform the pass B operation.

**Accumulators**

The multiplier outputs are fed into an accumulator. Each filter has its own accumulator. The accumulator can be set to accumulate the multiplier outputs or sum the multiplier outputs and send the result to the accumulator output register. When ACCEN is HIGH, both accumulators are enabled for accumulation and writing to the accumulator output registers is disabled (the registers hold their values). When ACCEN goes LOW, accumulation is halted (by sending zeros to the accumulator feedback inputs) and writing to the accumulator output registers is enabled.

**Mux/Adder**

When the LF43168 is configured as two FIR filters, the Mux/Adder is used to determine which filter drives the output port. When the LF43168 is configured as a single FIR filter, the Mux/Adder is used to sum the outputs of the two filters and send the result to the output port. If 10-bit data and 20-bit coefficients or 20-bit data and 10-bit coefficients are required, the Mux/Adder can facilitate this by scaling filter B's output by  $2^{-10}$  before being added to filter A's output. MUX1-0 determines what function the Mux/Adder performs (see Table 3).

The Mux/Adder is also used to round the output data before it is sent to the output port. Output data is rounded by adding a "1" to the bit position selected using bits 5-8 of Control Register 1 (see Table 2). For example, to round the

TABLE 3. MUX1-0 FUNCTION	
MUX1-0	FUNCTION
00	Filter A + Filter B (Filter B Scaled by $2^{-10}$ )
01	Filter A + Filter B
10	Filter A
11	Filter B

**FIGURE 3. SYMMETRIC COEFFICIENT SET EXAMPLES**



Even-Tap, Even-Symmetric  
Coefficient Set

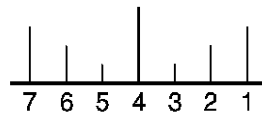

Odd-Tap, Even-Symmetric  
Coefficient Set

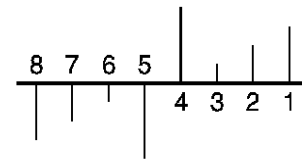

Even-Tap, Odd-Symmetric  
Coefficient Set

**FIGURE 4. EVEN-SYMMETRIC COEFFICIENT FILTER CONFIGURATIONS (NO DECIMATION)**

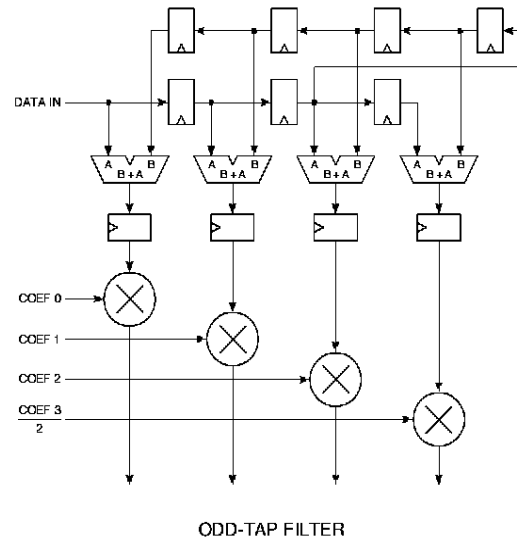
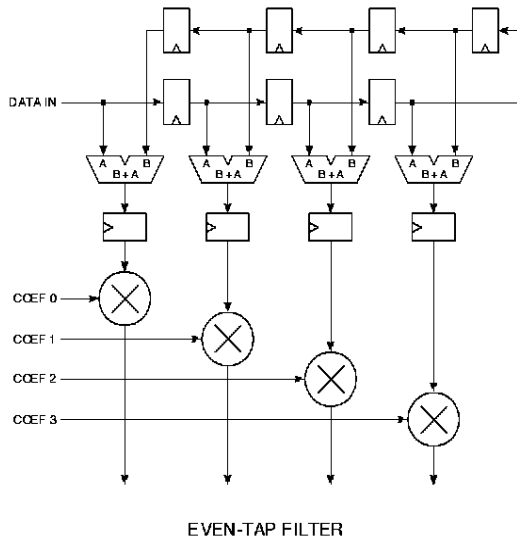

output to 16 bits, bits 5-8 of Control Register 1 should be set to "0011". This will cause a "1" to be added to bit position 2<sup>-7</sup>.

**Symmetric Coefficients**

The LF43168 filter architecture is optimized for symmetric filter coefficient sets. Figure 3 shows examples of the different types of symmetric coefficient sets. In even-symmetric sets, each coefficient value appears twice (except in odd-tap sets where the middle value appears only once). In odd-symmetric sets, each coefficient appears twice, but one value is positive and one is negative. If the

two data input values that will be multiplied by the same coefficient are added or subtracted before being sent to the filter multiplier, the number of multipliers needed for an N-tap filter is cut in half. Therefore, an 8-tap filter can be implemented with four multipliers if a symmetric coefficient set is used.

**FILTER CONFIGURATIONS**

Figures 4-6 show the data paths from filter input to filter multipliers for all symmetric coefficient filters. Figure 7 shows the interleaved coefficient filter configuration. Each diagram shows

one of the two FIR filters when the device is configured for dual filter mode. The diagrams can be expanded to include both filters when the device is configured for single filter mode.

**Even-Symmetric Coefficient Filters**

Figure 4 shows the two possible configurations when the device is programmed for even-symmetric coefficients and no decimation. Note that coefficient 3 on the odd-tap filter must be divided by two to get the correct result (The coefficient must be input to the device already divided by two).

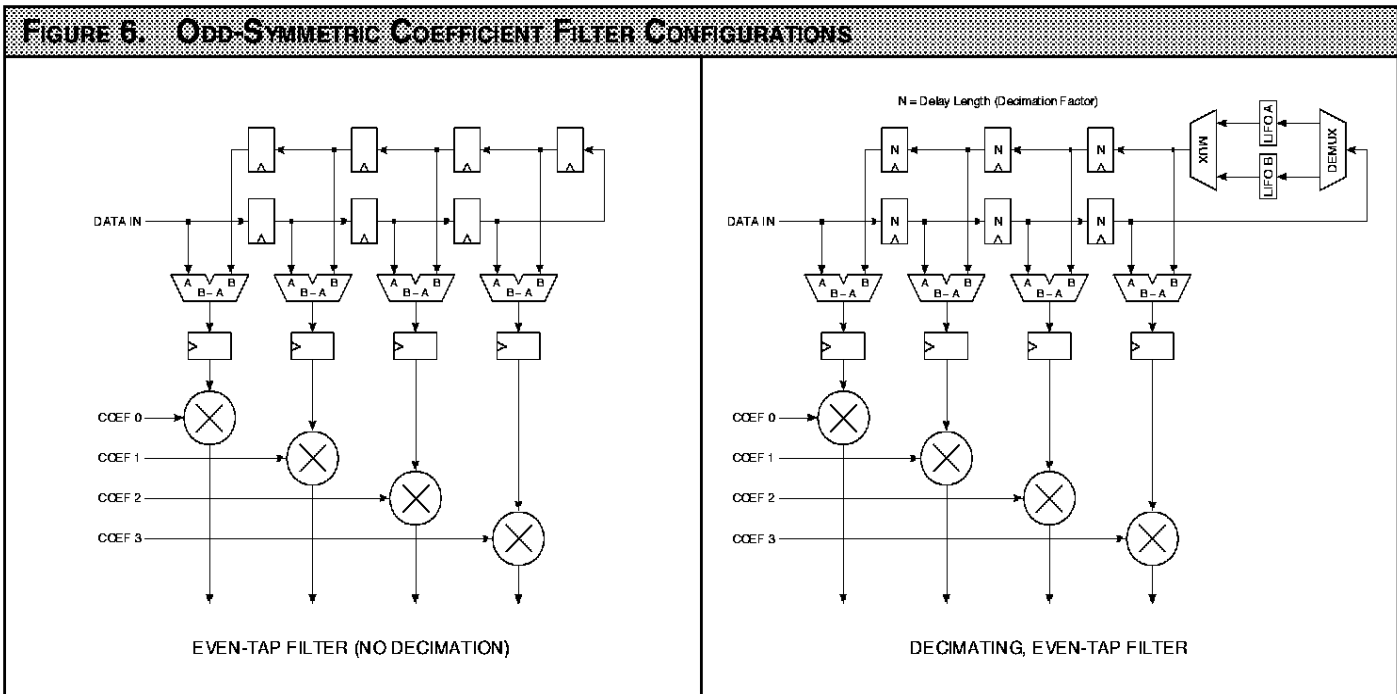
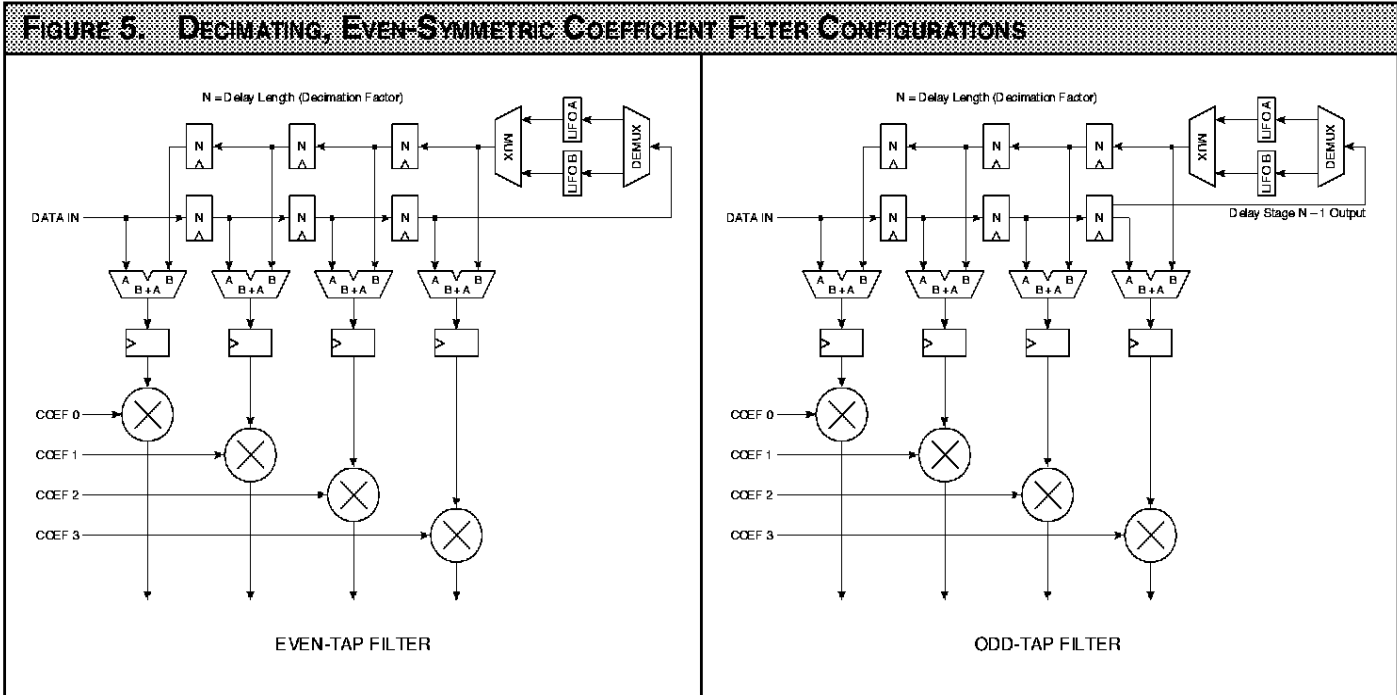

Figure 5 shows the two possible configurations when the device is programmed as a decimating, even-symmetric coefficient filter. The delay length of the decimation registers will be equal to the decimation factor that the device is programmed for. Since only four coefficients (effectively eight) can be sent to the filter multipli-

ers on a clock cycle, it may be necessary (depending on the coefficient set) to change the coefficients fed to the multipliers on different CLK cycles for filters with more than eight taps. Note that for the odd-tap filter, the middle coefficient of the coefficient set must be divided by two to get the correct result.

**Odd-Symmetric Coefficient Filters**

Figure 6 shows the two possible configurations when the device is programmed for odd-symmetric coefficients. Note that odd-tap, odd-symmetric coefficient filters are not possible.



**Interleaved Coefficient Filters**

Figure 7 shows the filter configuration when the device is programmed for interleaved coefficients. An interleaved coefficient set contains two separate odd-tap, even-symmetric coefficient sets which have been interleaved together (see Figure 8). If two data sets are interleaved into the same serial data stream, they can both be filtered by different coefficient sets if the two coefficient sets are also interleaved. The LF43168 is configured as an interleaved coefficient filter by programming the device for interleaved coefficient sets, even-symmetric coefficients, odd number of filter taps, and data reversal disabled. Note that coefficient 3, in Figure 7, must be divided by two to get the correct result.

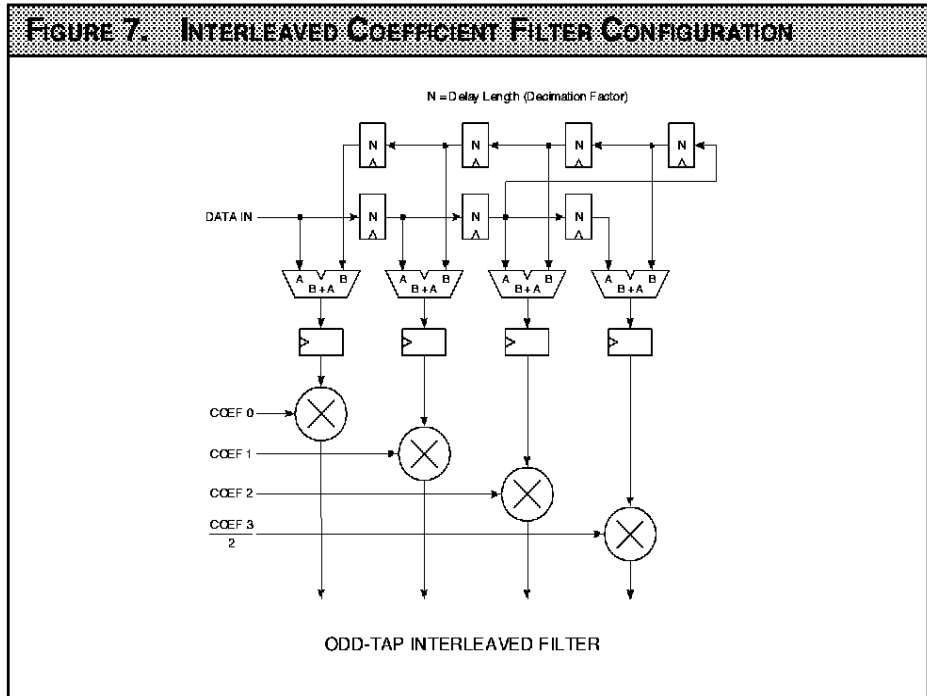

**Asymmetric Coefficient Filters**

It is possible to have asymmetric coefficient filters. Asymmetric coefficient sets do not exhibit even or odd symmetric properties. A 4-tap asymmetric filter is possible by putting the device in even-tap, pass A mode and then feeding the asymmetric coefficient set to the multipliers. An 8-tap asymmetric filter is possible if the device is clocked twice as fast as the input data rate. It will take two CLK cycles to calculate the output. On the first CLK cycle, the reverse decimation path is selected to feed data to the filter multipliers. On the second CLK cycle, the coefficients sent to the multipliers are changed (if necessary) and the forward decimation path is selected to feed data to the filter multipliers.

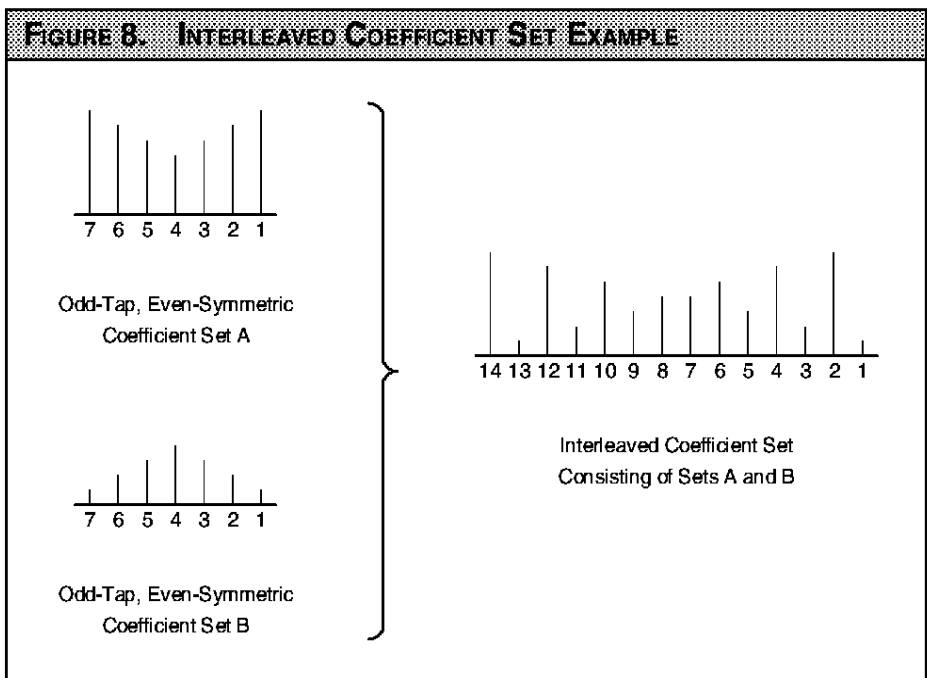

**MAXIMUM RATINGS** *Above which useful life may be impaired (Notes 1, 2, 3, 8)*

Storage temperature .....	-65°C to +150°C
Operating ambient temperature .....	-55°C to +125°C
V <sub>CC</sub> supply voltage with respect to ground .....	-0.5 V to +7.0 V
Input signal with respect to ground .....	-0.5 V to V <sub>CC</sub> + 0.5 V
Signal applied to high impedance output .....	-0.5 V to V <sub>CC</sub> + 0.5 V
Output current into low outputs .....	25 mA
Latchup current .....	> 400 mA

**OPERATING CONDITIONS** *To meet specified electrical and switching characteristics*

Mode	Temperature Range (Ambient)	Supply Voltage
Active Operation, Commercial	0°C to +70°C	4.75 V ≤ V <sub>CC</sub> ≤ 5.25 V
Active Operation, Military	-55°C to +125°C	4.50 V ≤ V <sub>CC</sub> ≤ 5.50 V

**ELECTRICAL CHARACTERISTICS** *Over Operating Conditions (Note 4)*

Symbol	Parameter	Test Condition	Min	Typ	Max	Unit
V <sub>OH</sub>	Output High Voltage	V <sub>CC</sub> = Min., I <sub>OH</sub> = -2.0 mA	2.6			V
V <sub>OL</sub>	Output Low Voltage	V <sub>CC</sub> = Min., I <sub>OL</sub> = 4.0 mA			0.4	V
V <sub>H</sub>	Input High Voltage		2.0		V <sub>CC</sub>	V
V <sub>L</sub>	Input Low Voltage	(Note 3)	0.0		0.8	V
I <sub>IX</sub>	Input Current	Ground ≤ V <sub>IN</sub> ≤ V <sub>CC</sub> (Note 12)			±10	μA
I <sub>OZ</sub>	Output Leakage Current	Ground ≤ V <sub>OUT</sub> ≤ V <sub>CC</sub> (Note 12)			±10	μA
I <sub>CC1</sub>	V <sub>CC</sub> Current, Dynamic	(Notes 5, 6)			300	mA
I <sub>CC2</sub>	V <sub>CC</sub> Current, Quiescent	(Note 7)			500	μA
C <sub>IN</sub>	Input Capacitance	T <sub>A</sub> = 25°C, f = 1 MHz			12	pF
C <sub>OUT</sub>	Output Capacitance	T <sub>A</sub> = 25°C, f = 1 MHz			12	pF

**SWITCHING CHARACTERISTICS**
**COMMERCIAL OPERATING RANGE** *Notes 9, 10 (ns)*

Symbol	Parameter	LF43168-					
		30		22		15	
		Min	Max	Min	Max	Min	Max
t <sub>CYC</sub>	Cycle Time	30		22		15	
t <sub>PW</sub>	Clock Pulse Width	12		8		7	
t <sub>S</sub>	Input Setup Time	15		12		5	
t <sub>H</sub>	Input Hold Time	0		0		0	
t <sub>WP</sub>	Write Period	30		22		15	
t <sub>WPW</sub>	Write Pulse Width	12		10		7	
t <sub>WHCH</sub>	Write High to Clock High	5		3		2	
t <sub>CWS</sub>	CIN <sub>9-0</sub> Setup Time	12		10		5	
t <sub>CWH</sub>	CIN <sub>9-0</sub> Hold Time	0		0		0	
t <sub>AWS</sub>	Address Setup Time	10		8		5	
t <sub>AWH</sub>	Address Hold Time	0		0		0	
t <sub>D</sub>	Output Delay		14		12		11
t <sub>ENA</sub>	Three-State Output Enable Delay (Note 11)		12		12		12
t <sub>DIS</sub>	Three-State Output Disable Delay (Note 11)		12		12		12

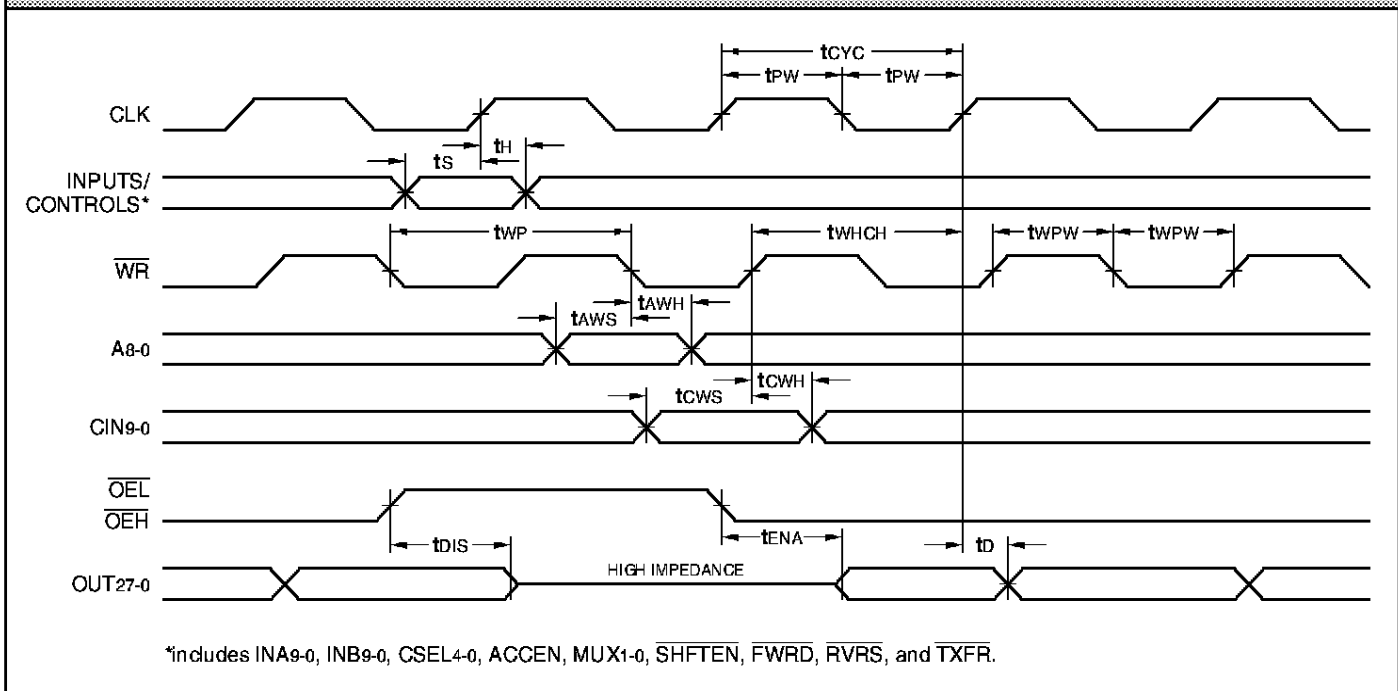
**SWITCHING WAVEFORMS**

**SWITCHING CHARACTERISTICS**
**MILITARY OPERATING RANGE** *Notes 9, 10 (ms)*

Symbol	Parameter	LF43168-					
		39		30		22	
		Min	Max	Min	Max	Min	Max
t <sub>CYC</sub>	Cycle Time	39		30		22	
t <sub>PW</sub>	Clock Pulse Width	15		12		8	
t <sub>S</sub>	Input Setup Time	17		15		12	
t <sub>H</sub>	Input Hold Time	0		0		0	
t <sub>WP</sub>	Write Period	39		30		22	
t <sub>WPW</sub>	Write Pulse Width	15		12		10	
t <sub>WHCH</sub>	Write High to Clock High	8		5		3	
t <sub>CWS</sub>	CIN <sub>9-0</sub> Setup Time	15		12		10	
t <sub>CWH</sub>	CIN <sub>9-0</sub> Hold Time	0		0		0	
t <sub>AWS</sub>	Address Setup Time	10		10		8	
t <sub>AWH</sub>	Address Hold Time	0		0		0	
t <sub>D</sub>	Output Delay		17		15		12
t <sub>ENA</sub>	Three-State Output Enable Delay (Note 11)		12		12		12
t <sub>DIS</sub>	Three-State Output Disable Delay (Note 11)		12		12		12

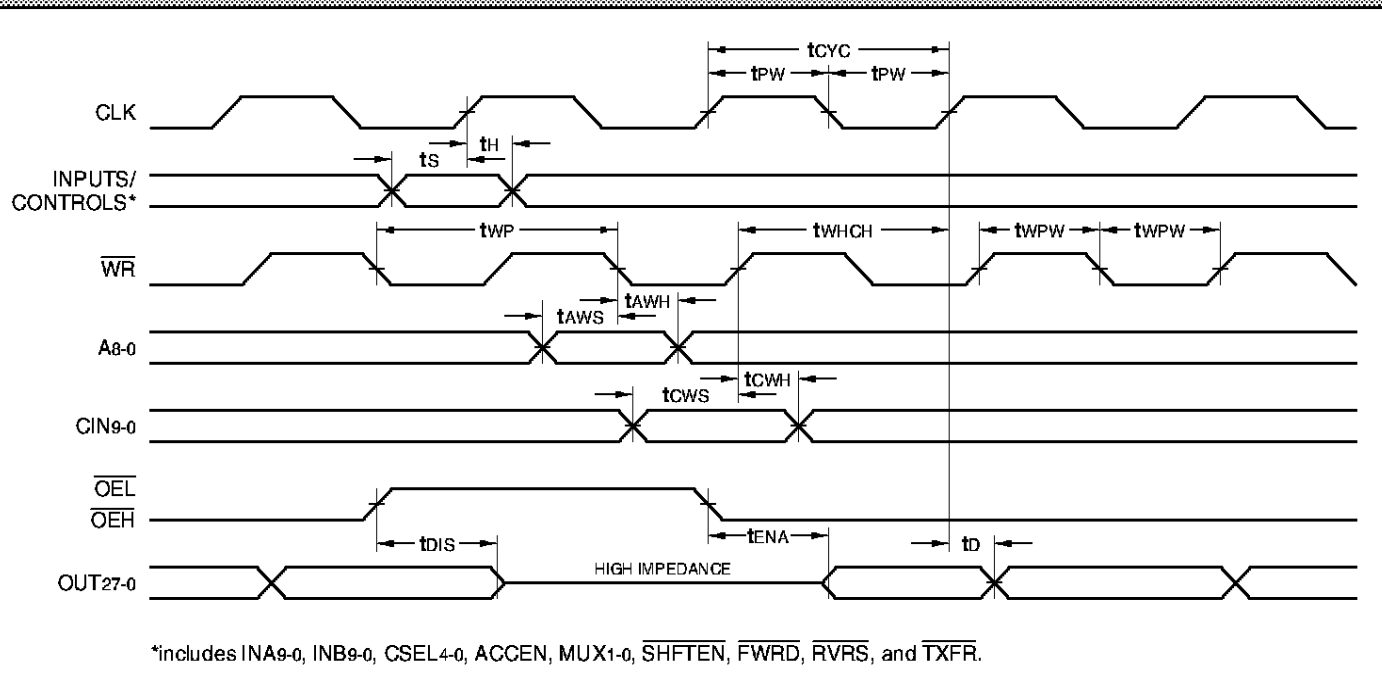
**SWITCHING WAVEFORMS**

**NOTES**

1. Maximum Ratings indicate stress specifications only. Functional operation of these products at values beyond those indicated in the Operating Conditions table is not implied. Exposure to maximum rating conditions for extended periods may affect reliability.

2. The products described by this specification include internal circuitry designed to protect the chip from damaging substrate injection currents and accumulations of static charge. Nevertheless, conventional precautions should be observed during storage, handling, and use of these circuits in order to avoid exposure to excessive electrical stress values.

3. This device provides hard clamping of transient undershoot and overshoot. Input levels below ground or above VCC will be clamped beginning at -0.6 V and VCC + 0.6 V. The device can withstand indefinite operation with inputs in the range of -0.5 V to +7.0 V. Device operation will not be adversely affected, however, input current levels will be well in excess of 100 mA.

4. Actual test conditions may vary from those designated but operation is guaranteed as specified.

5. Supply current for a given application can be accurately approximated by:

$$\frac{NCV^2F}{4}$$

where

4

N = total number of device outputs

C = capacitive load per output

V = supply voltage

F = clock frequency

6. Tested with all outputs changing every cycle and no load, at a 20 MHz clock rate.

7. Tested with all inputs within 0.1 V of VCC or Ground, no load.

8. These parameters are guaranteed but not 100% tested.

9. AC specifications are tested with input transition times less than 3 ns, output reference levels of 1.5 V (except tDIS test), and input levels of nominally 0 to 3.0 V. Output loading may be a resistive divider which provides for specified IOH and IOL at an output voltage of VOH min and VOL max respectively. Alternatively, a diode bridge with upper and lower current sources of IOH and IOL respectively, and a balancing voltage of 1.5 V may be used. Parasitic capacitance is 30 pF minimum, and may be distributed.

This device has high-speed outputs capable of large instantaneous current pulses and fast turn-on/turn-off times. As a result, care must be exercised in the testing of this device. The following measures are recommended:

a. A 0.1 μF ceramic capacitor should be installed between VCC and Ground leads as close to the Device Under Test (DUT) as possible. Similar capacitors should be installed between device VCC and the tester common, and device ground and tester common.

b. Ground and VCC supply planes must be brought directly to the DUT socket or contactor fingers.

c. Input voltages should be adjusted to compensate for inductive ground and VCC noise to maintain required DUT input levels relative to the DUT ground pin.

10. Each parameter is shown as a minimum or maximum value. Input requirements are specified from the point of view of the external system driving the chip. Setup time, for example, is specified as a minimum since the external system must supply at least that much time to meet the worst-case requirements of all parts. Responses from the internal circuitry are specified from the point of view of the device. Output delay, for example, is specified as a maximum since worst-case operation of any device always provides data within that time.

11. For the tENA test, the transition is measured to the 1.5 V crossing point with datasheet loads. For the tDIS test, the transition is measured to the ±200mV level from the measured steady-state output voltage with ±10mA loads. The balancing voltage, VTH, is set at 3.5 V for Z-to-0 and 0-to-Z tests, and set at 0 V for Z-to-1 and 1-to-Z tests.

12. These parameters are only tested at the high temperature extreme, which is the worst case for leakage current.

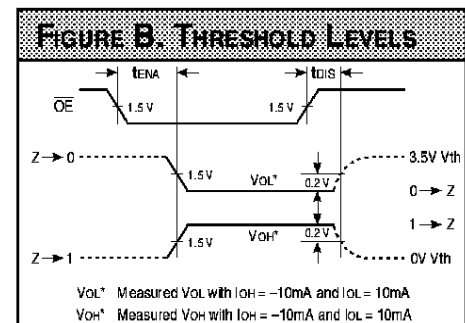
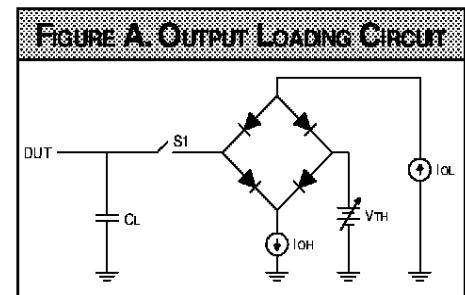

**ORDERING INFORMATION**

84-pin

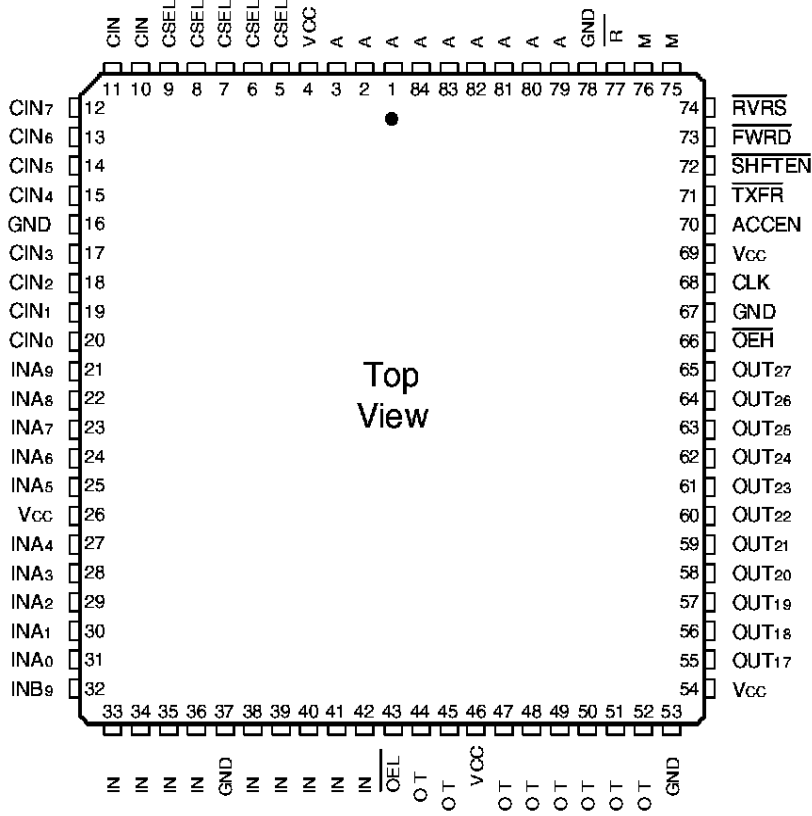

Speed	Plastic J-Lead Chip Carrier (J3)	
<b>0°C to +70°C — COMMERCIAL SCREENING</b>		
30 ns		LF43168JC30
22 ns		LF43168JC22
15 ns		LF43168JC15
<b>-40°C to +85°C — COMMERCIAL SCREENING</b>		
30 ns		LF43168JI30
22 ns		LF43168JI22
15 ns		LF43168JI15

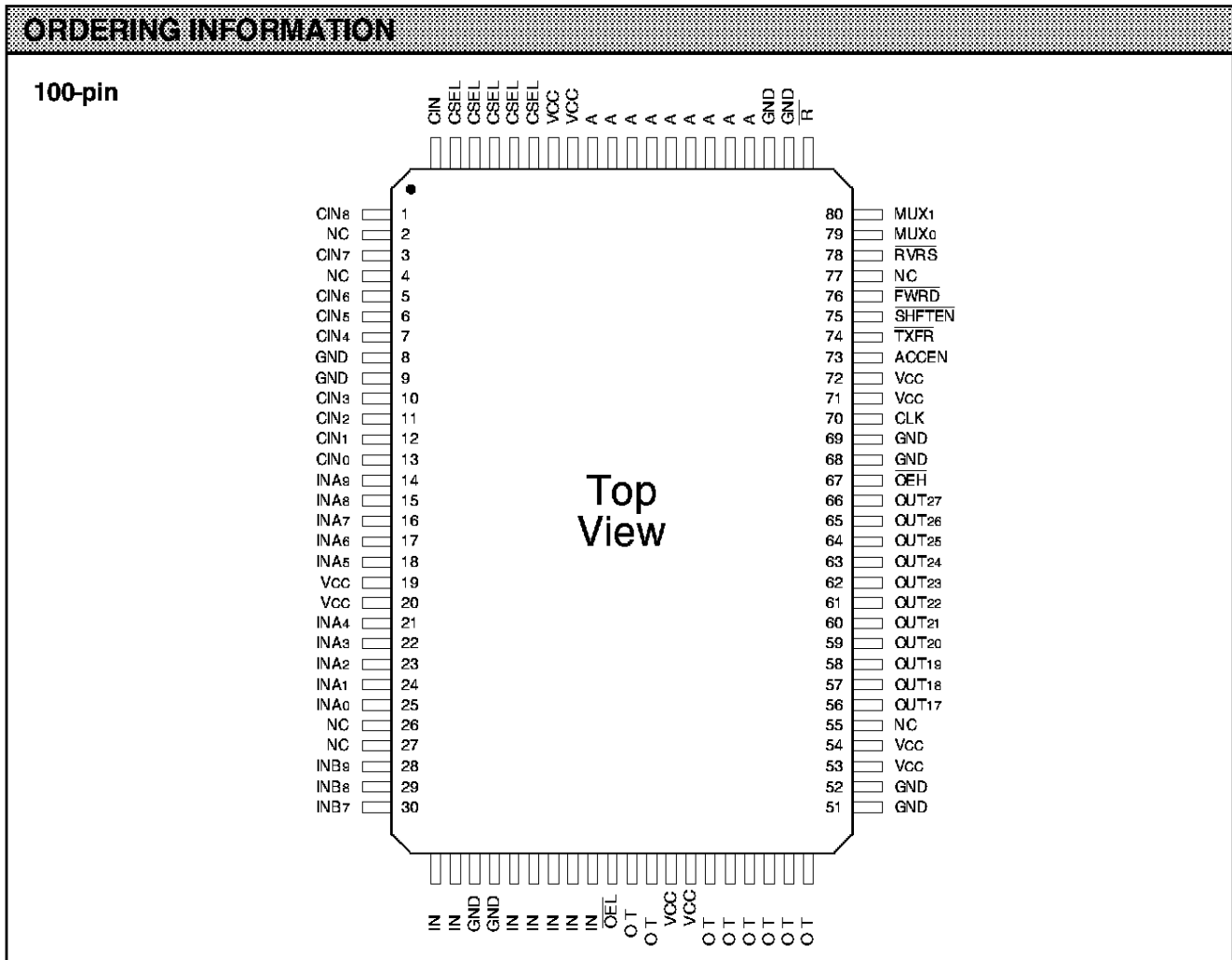

<b>Plastic Quad Flatpack (Q2)</b>		
<b>Speed</b>		
	<b>0°C to +70°C — COMMERCIAL SCREENING</b>	
30 ns	LF43168QC30	
22 ns	LF43168QC22	
15 ns	LF43168QC15	
	<b>-40°C to +85°C — COMMERCIAL SCREENING</b>	
30 ns	LF43168QI30	
22 ns	LF43168QI22	
15 ns	LF43168QI15	

#### ORDERING INFORMATION

84-pin

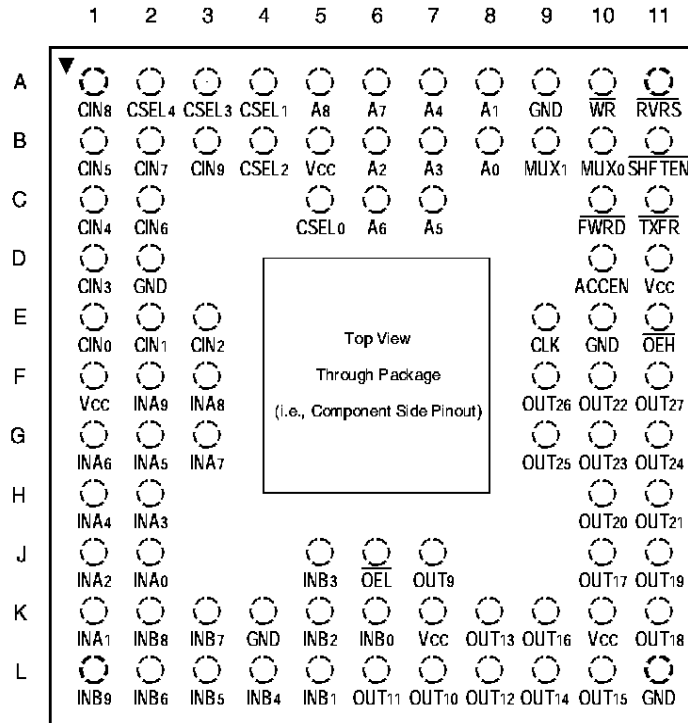

Speed	Ceramic Pin Grid Array (G6)
<b>0°C to +70°C — COMMERCIAL SCREENING</b>	
30 ns	LF43168GC30
22 ns	LF43168GC22
15 ns	LF43168GC15
<b>-55°C to +125°C — COMMERCIAL SCREENING</b>	
39 ns	
30 ns	
22 ns	
<b>-55°C to +125°C — MIL-STD-883 COMPLIANT</b>	
39 ns	LF43168GMB39
30 ns	LF43168GMB30
22 ns	LF43168GMB22