

## Half-Bridge N-Channel MOSFET Driver With Break-Before-Make

### DESCRIPTION

The SiP41101 is a high speed half-bridge driver, with make-before-break, for use in high frequency, high current multiphase dc-to-dc power supplies for supply voltages as high as 30 V. It is designed to operate at frequencies up to 1 MHz. The high-side driver is bootstrapped to allow driving an N-Channel high-side MOSFET. The bootstrap diode is internal. The output drivers provide currents up to 4 A, allowing use of low  $R_{DS(on)}$  power MOSFETs.

The SiP41101 comes with internal break-before-make circuitry to prevent shoot-through current in the external MOSFETs. The  $\overline{SD}$  control pin is provided to enable the drivers. A Synchronous Enable control pin is provided to disable the the low-side or synchronous MOSFET to maximize efficiency under low output current conditions.

The SiP41101 is available in both standard and lead (Pb)-free 16-pin TSSOP packages for operation over the industrial temperature range of - 40 to 85 °C.

### FEATURES

- 5 V gate drive
- Undervoltage lockout
- Sub 1  $\Omega$  gate drivers
- Internal bootstrap diode
- Drive MOSFETs In 4.5 V to 30 V systems
- Switching frequency: 250 kHz to 1 MHz
- Synchronous enable/disable option

### APPLICATIONS

- Multi-phase dc-to-dc
- High current synchronous buck converters
- High frequency synchronous buck converters
- Asynchronous-to-synchronous adaptations
- Mobile computer dc-to-dc converters
- Desktop computer dc-to-dc converters

### TYPICAL APPLICATION CIRCUIT

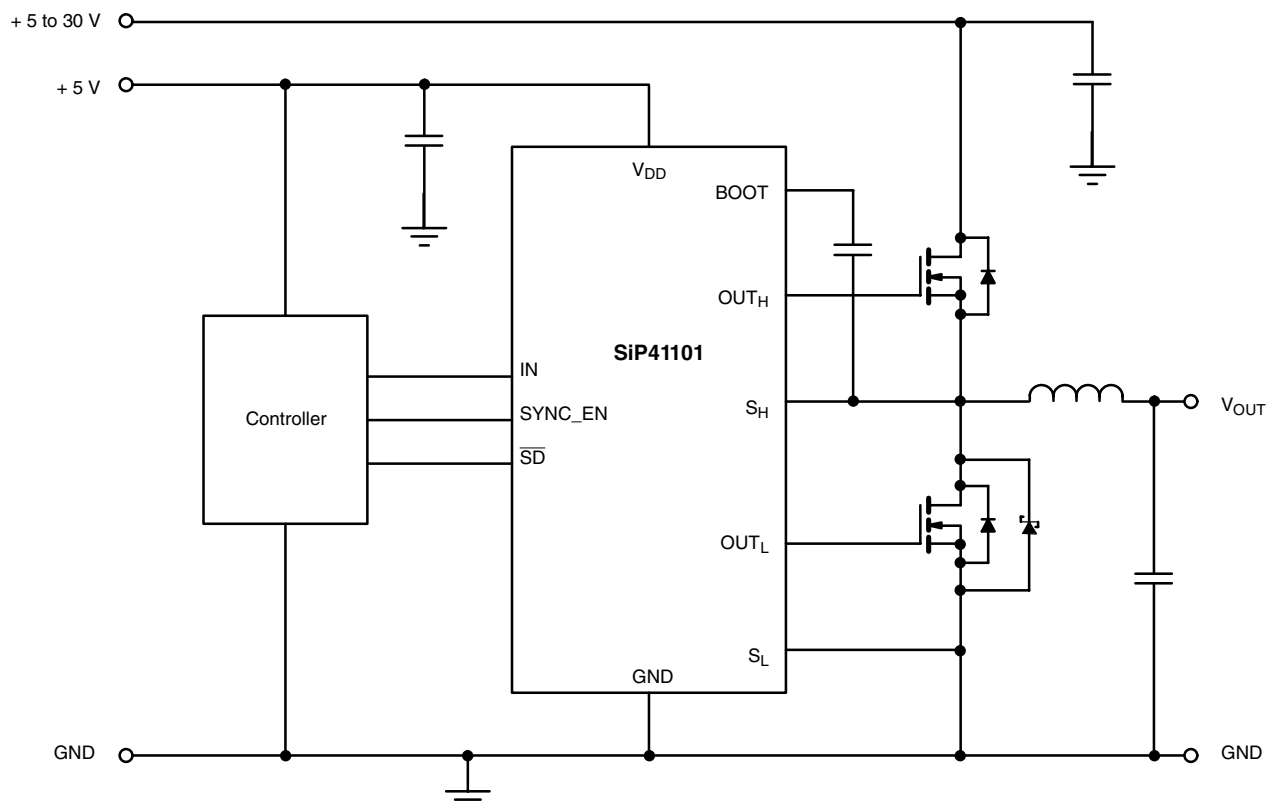

<b>ABSOLUTE MAXIMUM RATINGS</b> all voltages referenced to GND = 0 V			
Parameter	Limit	Unit	
$V_{DD}$	7	V	
$V_{IN}$	- 0.3 to $V_{DD} + 0.3$		
$V_{SH}$	30		
$V_{BOOT}$	$V_{SH} + 7$		
Storage Temperature	- 40 to 150	°C	
Operating Junction Temperature	125		
Power Dissipation <sup>a</sup>	TSSOP-16	925	mW
Thermal Impedance ( $\Theta_{JA}$ ) <sup>a</sup>		135	°C/W

Notes:

a. Device Mounted with all leads soldered or welded to PC board.

Stresses beyond those listed under "Absolute Maximum Ratings" may cause permanent damage to the device. These are stress ratings only, and functional operation of the device at these or any other conditions beyond those indicated in the operational sections of the specifications is not implied. Exposure to absolute maximum rating conditions for extended periods may affect device reliability.

<b>RECOMMENDED OPERATING RANGE</b> all voltages referenced to GND = 0 V		
Parameter	Limit	Unit
$V_{DD}$	4.5 V to 5.5 V	V
$V_{BOOT}$	4.5 V to 30 V	
$C_{BOOT}$	100 nF to 1 $\mu$ F	
Operating Temperature Range	- 40 to 85	°C

<b>SPECIFICATIONS<sup>a</sup></b>						
Parameter	Symbol	Test Conditions Unless Specified $V_{DD} = 4.5$ V to 5.5 V, $V_{BOOT} = 4.5$ to 30 V, $T_A = -40$ to 85 °C	Limits			Unit
			Min. <sup>a</sup>	Typ. <sup>b</sup>	Max. <sup>a</sup>	
<b>Power Supplies</b>						
Supply Voltage	$V_{DD}$		4.5		5.5	V
Supply Current	$I_{DD}$	$f_{IN} = 300$ kHz, $\overline{SD} = H$ , Sync_en = H see Figure 1		25	40	mA
Quiescent Current	$I_{DDQ}$	IN = L, $\overline{SD} = H$ , Sync_en = H, No Load		1.4	2.5	
<b>Reference Voltage</b>						
Break-Before-Make	$V_{BBM}$	$V_{DD} = 5.5$ V		2.5		V
<b>Logic Inputs - IN, Sync En, <math>\overline{SD}</math></b>						
Input High	$V_{IH}$		2.5			V
Input Low	$V_{IL}$				1.0	
<b>Undervoltage Lockout</b>						
$V_{DD}$ Undervoltage	$V_{UVL}$	$V_{DD}$ Rising	2.5	3.6	4.4	V
Undervoltage Hysteresis	$V_{HYST}$			400		mV
<b>Bootstrap Diode</b>						
Forward Voltage	$V_F$	$I_F = 10$ mA		0.65		V
<b>MOSFET Drivers</b>						
High Side Drive Current <sup>c</sup>	$I_{PKH(source)}$	$V_{BOOT} - V_{SH} = 4.5$ V, $V_{OUTH} - V_{SA} = 2.25$ V		3.0		A
	$I_{PKH(sink)}$			3.0		
Low Side Drive Current <sup>c</sup>	$I_{PKL(source)}$	$V_{DD} = 4.5$ V, $V_{OUTL} = 2.25$ V		4.1		
	$I_{PKL(sink)}$			4.1		
High Side Driver Impedance	$R_{DH(source)}$	$V_{DD} = 4.5$ V SH = GND		0.75	1.3	$\Omega$
	$R_{DH(sink)}$			0.75	1.3	
Low Side Driver Impedance	$R_{DL(source)}$	$V_{DD} = 4.5$ V		0.55	1.1	
	$R_{DL(sink)}$			0.55	1.1	

<b>SPECIFICATIONS<sup>a</sup></b>						
Parameter	Symbol	Test Conditions Unless Specified $V_{DD} = 4.5\text{ V to }5.5\text{ V}, V_{BOOT} = 4.5\text{ to }30\text{ V}, T_A = -40\text{ to }85\text{ }^\circ\text{C}$	Limits			Unit
			Min. <sup>a</sup>	Typ. <sup>b</sup>	Max. <sup>a</sup>	
<b>MOSFET Drivers</b>						
High-Side Rise Time <sup>c</sup>	$t_{rH}$	10 % - 90 %		15		ns
High-Side Fall Time <sup>c</sup>	$t_{fH}$	90 % - 10 %		15		
High Side Propagation Delay <sup>c</sup>	$t_{d(off)H}$	50 % - 50 %		25		
	$\Delta t_{H-L}$			5		
Low-Side Rise Time <sup>c</sup>	$t_{rL}$	10 % - 90 %		25		
Low-Side Fall Time <sup>c</sup>	$t_{fL}$	90 % - 10 %		15		
Low Side Propagation Delay <sup>c</sup>	$t_{d(off)L}$	50 % - 50 %		10		
	$\Delta t_{L-H}$			25		

Notes:

a. The algebraic convention whereby the most negative value is a minimum and the most positive a maximum (-40° to 85 °C).

b. Typical values are for DESIGN AID ONLY, not guaranteed nor subject to production testing.

c. Guaranteed by design.

### TIMING WAVEFORMS

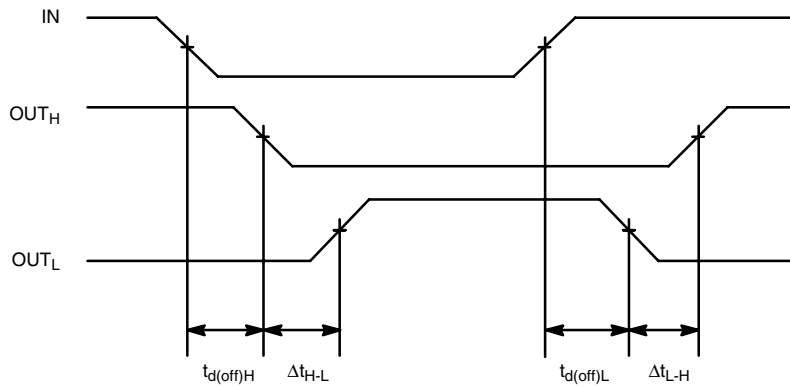

### TEST SETUP

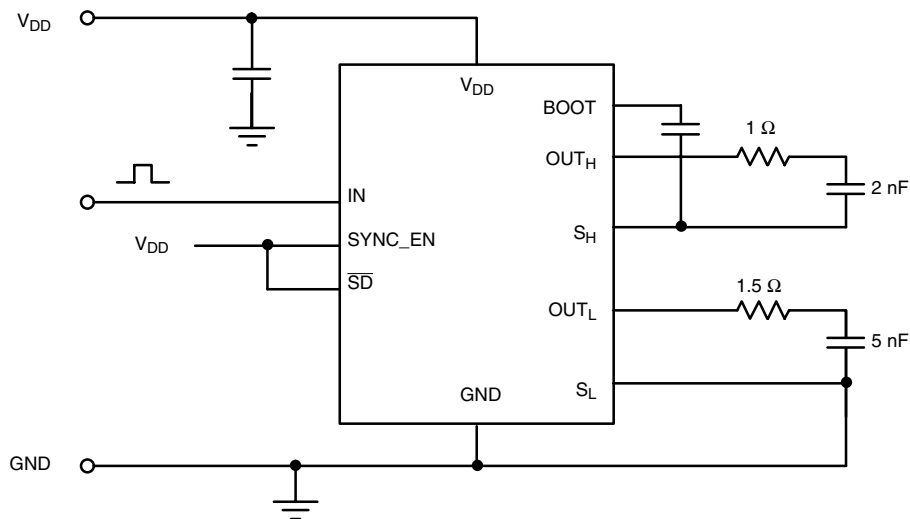
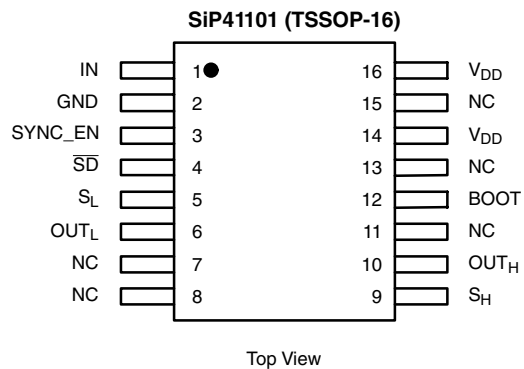

Figure 1.

## PIN CONFIGURATION, ORDERING INFORMATION, AND TRUTH TABLE



## ORDERING INFORMATION

Part Number	Temperature Range	Marking
SiP41101DQ-T1	- 40 to 85 °C	41101
SiP41101DQ-T1-E3		

Eval Kit	Temperature Range
SiP41101DB	- 40 to 85 °C

## TRUTH TABLE

$\overline{SD}$	SYNC_EN	IN	OUT <sub>H</sub>	OUT <sub>L</sub>
H	H	L	L	H
H	H	H	H	L
H	L	L	L	L
H	L	H	H	L
L	X	X	L	L

## PIN DESCRIPTION

Pin	Name	Function
1	IN	Input signal to the MOSFET drivers
2	GND	Ground
3	SYNC_EN	Synchronous MOSFET enable
4	$\overline{SD}$	Shutdown
5	S <sub>L</sub>	Connection to source of low-side MOSFET
6	OUT <sub>L</sub>	Synchronous or low-side MOSFET gate drive
7, 8, 11, 13, 15	NC	No Connect
9	S <sub>H</sub>	Connection to source of high-side MOSFET
10	OUT <sub>H</sub>	Control or high-side MOSFET gate drive
12	BOOT	Connection for the bootstrap capacitor
14, 16	V <sub>DD</sub>	+ 5 V supply

**FUNCTIONAL BLOCK DIAGRAM**

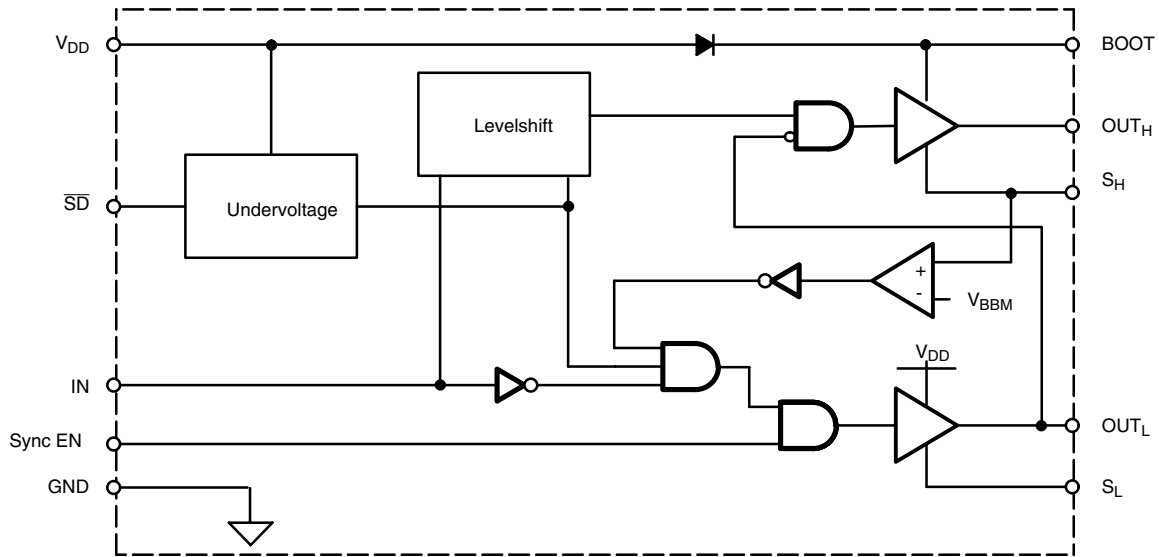

Figure 2.

**DETAILED OPERATION**

**Break-Before-Make Function**

The SiP41101 has an internal break-before-make function to ensure that both high-side and low-side MOSFETs are not turned on at the same time. The high-side drive ( $OUT_H$ ) will not turn on until the low-side gate drive voltage (measured at the  $OUT_L$  pin) is less than  $V_{BBM}$ , thus ensuring that the low-side MOSFET is turned off. The low-side drive ( $OUT_L$ ) will not turn on until the voltage at the MOSFET half-bridge output (measured at the  $S_L$  pin) is less than  $V_{BBM}$ , thus ensuring that the high-side MOSFET is turned.

**Under Voltage Lockout Function**

The SiP41101 has an internal under-voltage lockout feature to prevent driving the MOSFET gates when the supply voltage (at  $V_{DD}$ ) is less than the under-voltage lockout specification ( $V_{UVL}$ ). This prevents the output MOSFETs from being turned on without sufficient gate voltage to ensure they are fully on. There is hysteresis included in this feature to prevent lockout from cycling on and off.

**TYPICAL CHARACTERISTICS** 25 °C, unless otherwise noted

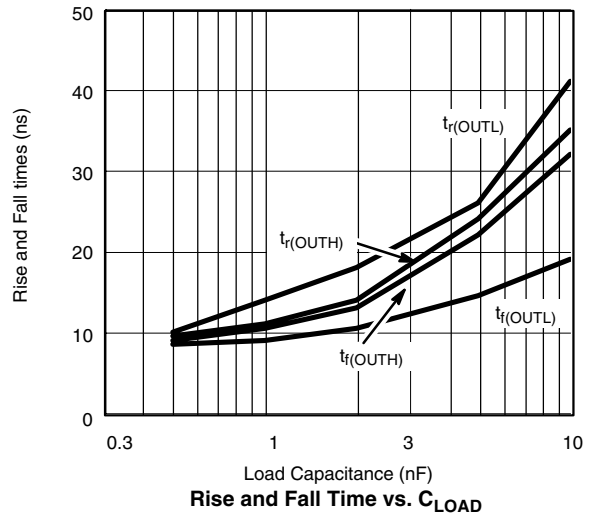
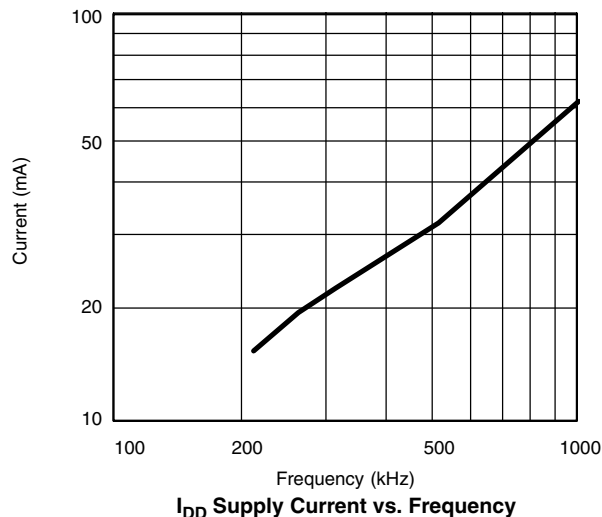

## TYPICAL WAVEFORMS

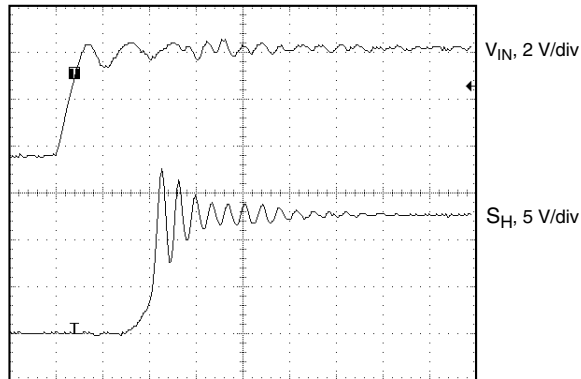

25 ns/div

**V<sub>IN</sub> Rising vs. SH**

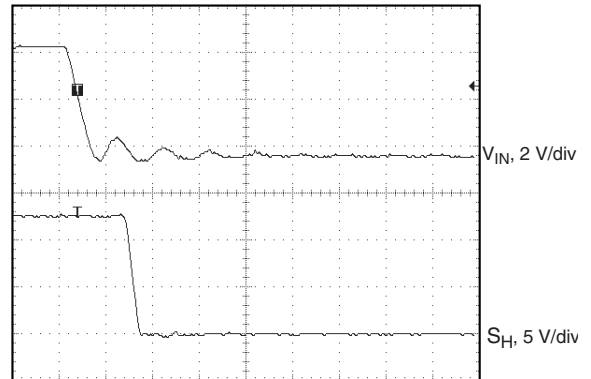

25 ns/div

**V<sub>IN</sub> Falling vs. SH**

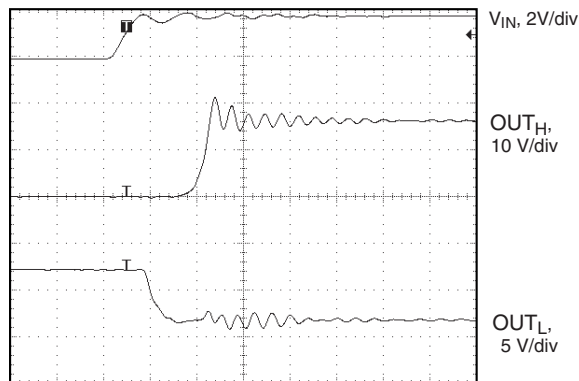

25 ns/div

**V<sub>IN</sub> Rising vs. OUT<sub>H</sub> and OUT<sub>L</sub>**

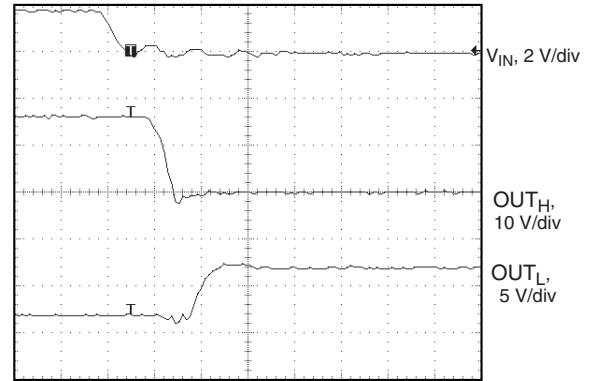

25 ns/div

**V<sub>IN</sub> Falling vs. OUT<sub>H</sub> and OUT<sub>L</sub>**

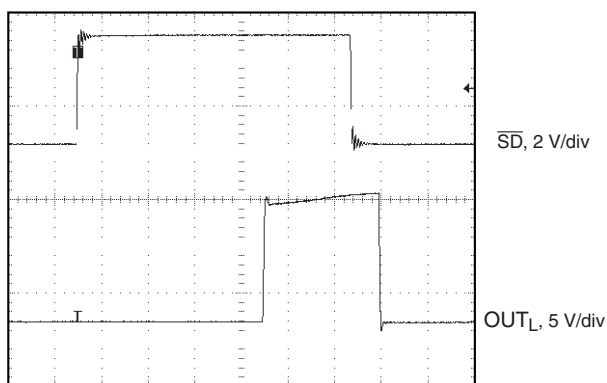

400 ns/div  
**SD vs. OUT<sub>L</sub>**

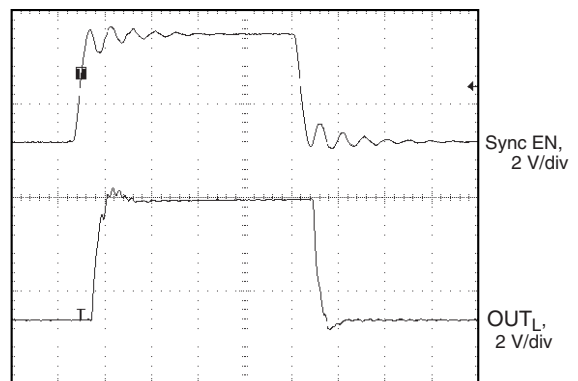

50 ns/div  
**Sync EN vs. OUT<sub>L</sub>**

Vishay Siliconix maintains worldwide manufacturing capability. Products may be manufactured at one of several qualified locations. Reliability data for Silicon Technology and Package Reliability represent a composite of all qualified locations. For related documents such as package/tape drawings, part marking, and reliability data, see <http://www.vishay.com/ppg?72377>.



## Disclaimer

All product specifications and data are subject to change without notice.

Vishay Intertechnology, Inc., its affiliates, agents, and employees, and all persons acting on its or their behalf (collectively, "Vishay"), disclaim any and all liability for any errors, inaccuracies or incompleteness contained herein or in any other disclosure relating to any product.

Vishay disclaims any and all liability arising out of the use or application of any product described herein or of any information provided herein to the maximum extent permitted by law. The product specifications do not expand or otherwise modify Vishay's terms and conditions of purchase, including but not limited to the warranty expressed therein, which apply to these products.

No license, express or implied, by estoppel or otherwise, to any intellectual property rights is granted by this document or by any conduct of Vishay.

The products shown herein are not designed for use in medical, life-saving, or life-sustaining applications unless otherwise expressly indicated. Customers using or selling Vishay products not expressly indicated for use in such applications do so entirely at their own risk and agree to fully indemnify Vishay for any damages arising or resulting from such use or sale. Please contact authorized Vishay personnel to obtain written terms and conditions regarding products designed for such applications.

Product names and markings noted herein may be trademarks of their respective owners.