

Fig. 1

- Series 3XX are available with straight and right angle solder tails.
- Series 350 & 399...009 use MM# 3404 & 5011 pins. (See pages 170 & 172 for details)
- Series 310 & 399...003 use MM# 1001 & 1103 receptacles (see pages 134 & 135 for details)
- Receptacles use Hi-Rel, 4-finger #30 contact rated at 3 amps.
- Hi-Temp thermoplastic insulator available upon request.



Ordering Information

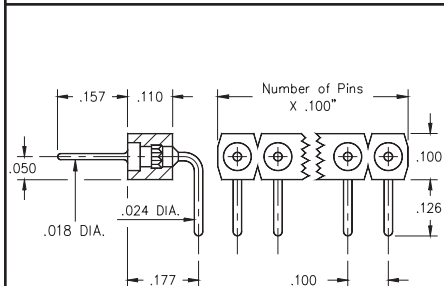

Fig. 2

Fig. 1	Series 350...006	Straight Pin Header
	350-XX-1__-00-006 Specify # of pins → 01-64	
Fig. 2	Series 399...009	Right Angle Pin Header
	399-XX-1__-10-009 Specify # of pins → 01-64	

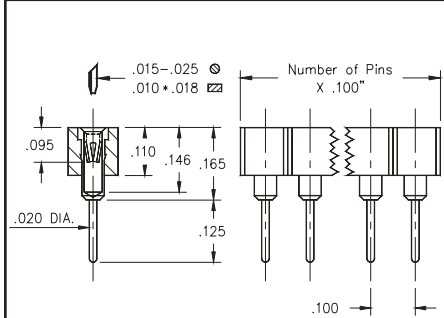

Fig. 3

XX= Plating Code See Below

SPECIFY PLATING CODE XX=	10	90		
Pin Plating	10μ" Au	200μ" Sn/Pb		

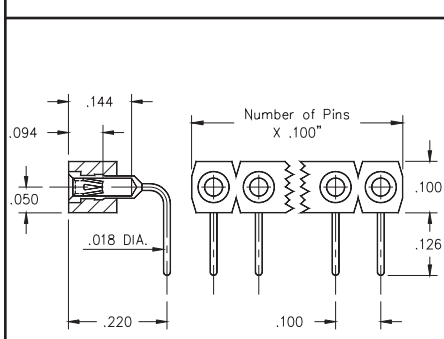

Fig. 4

Fig. 3	Series 310...001	Straight Socket
	310-XX-1__-41-001 Specify # of pins → 01-64	
Fig. 4	Series 399...003	Right Angle Socket
	399-XX-1__-10-003 Specify # of pins → 01-64	

XX= Plating Code See Below

SPECIFY PLATING CODE XX=	13	91	93	99
Sleeve (Pin)	10μ" Au	200μ" Sn/Pb	200μ" Sn/Pb	200μ" Sn/Pb
Contact (Clip)	30μ" Au	10μ" Au	30μ" Au	200μ" Sn/Pb