

Dot Matrix LED Unit for Indoor/Outdoor Use LT1455M/LT1456M(Lamp Type)

■ Features

- No. of dots : 16X16dots
- Outline dimensions : 96.0X96.0mm
- Dot size : φ5.0mm
- Dot pitch : 6.0mm
- Radiation color : Yellow-green+Red(High-luminosity)dichromatic type
- Driving method : 1/8 duty dynamic drive

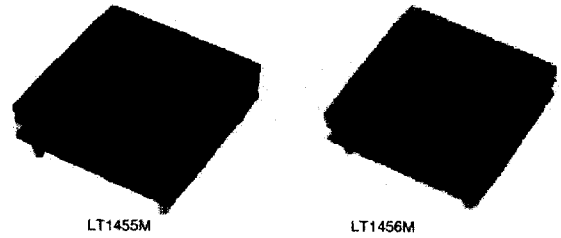

■ Absolute Maximum Ratings

(Ta=25°C)

Supply voltage for IC	VCC	-0.3 to +6.0	V
Supply voltage for LED	VLED	-0.3 to +5.5	V
Input voltage	VI	-0.3 to VCC+0.3	V
Turn-on time	ton	1	ms
Operating temperature	Topr	-10 to +65	°C
Storage temperature	Tstg	-20 to +85	°C
Power dissipation	P	22	W

■ Optical Characteristics

(VCC=5V, VLED=5V, Ta=25°C)

Viewing angle	2θ1/2	50/40	°
Peak emission wavelength	Red	660	nm
	Yellow-green	565	

Each figure in the table is the one of LT1455M/LT1456M in sequence.

■ Luminance

Luminance is classified into 2 ranks shown below.

(VCC=5V, VLED=5V, Ta=25°C)

Red	450/700	550/1000	cd/m ²
Yellow-green	330/700	450/1000	

Each figure in the table is the one of LT1455M/LT1456M in sequence.

■ Terminal Functions

Power supply (CN1)	VLED	Supply voltage for LED(+5V)
	VCC	Supply voltage for IC(+5V)
	GND1	Ground for IC
	GND2	Ground for LED
Input signal (CN2)	A0 to A2	Address specification signal for column driver
	RENABLE GENABLE	Controls ON/OFF of each color of LED (H: LED OFF)
	RDATA	Serial data input for red(H=ON, L=OFF) Shift from up to down in the unit HD16→HD31→HD0→HD15
	GDATA	Serial data input for yellow-green(H=ON, L=OFF) Shift from up to down in the unit HD16→HD31→HD0→HD15
	LATCH	Latch signal of display data H: Serial data is converted to parallel data.L: Contents are latched.
	CLOCK	Clock signal for data transmission in the shift-register.(L→H: serial data is shifted.)
	GND1	Ground for signal (Connected to ground for IC)
Output signal (CN3)	A0 to A2	Buffered input signal
	RENABLE	Buffered input signal
	RDATA	Input signal generated through 32-bit shift register
	GDATA	Input signal generated through 32-bit shift register
	LATCH	Buffered input signal
	GENABLE	Buffered input signal
	CLOCK	Buffered input signal
GND1	Ground for signal (Connected to ground for IC)	

Each signal is used as input signal for next unit.

* As for the terminal number, refer to the outline dimensions

- (Notice) • In the absence of confirmation by device specification sheets, SHARP takes no responsibility for any defects that may occur in equipment using any SHARP devices shown in catalogs, data books, etc. Contact SHARP in order to obtain the latest device specification sheets before using any SHARP device.
- (Internet) • Data for sharp's optoelectronic/power device is provided for internet.(Address <http://www.sharp.co.jp/ecg/>)

■ Electrical Characteristics

(VCC=5V, VLED=5V, Ta=25°C)

Supply voltage for IC	VCC	4.75	5.0	5.25	V
Supply voltage for LED	VLED	4.5	5.0	5.25	V
IC current dissipation	ICC	—	15	40	mA
LED current dissipation*1	ILED	—	3.5	3.9	A
Signal input voltage	VIL	3.5	—	—	V
	VIH	—	—	1.5	V
Signal input current	IIL	—	—	0.1	μA
	IiH	—	—	0.12	mA
Clock frequency	fCLK	—	—	3.0	MHz
Frame frequency	fFR	125	200	400	Hz

*1 Under the condition that dichromatic all dots are lit.

■ Timing Chart

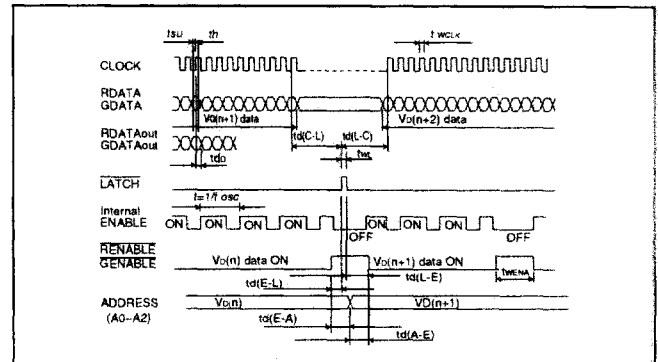

■ Block Diagram

