

N-Channel Enhancement Mode Power MOSFET

■ Features

- Capable of 2.5V Gate Drive
- Small Package Outline
- Surface Mount Package

■ General Description

The advanced power MOSFET provides the designer with the best combination of fast switching, low on-resistance and cost-effectiveness.

■ Product Summary

BV_{DSS} (V)	$R_{DS(ON)}$ (m Ω)	I_D (A)
20	85	3.2

■ Pin Assignments

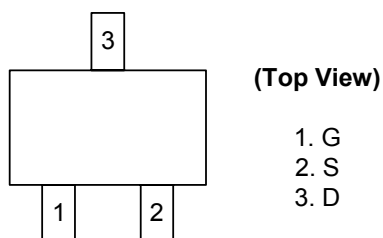

■ Pin Descriptions

Pin No.	Pin Name	Description
1	G	Gate
2	S	Source
3	D	Drain

■ Ordering information

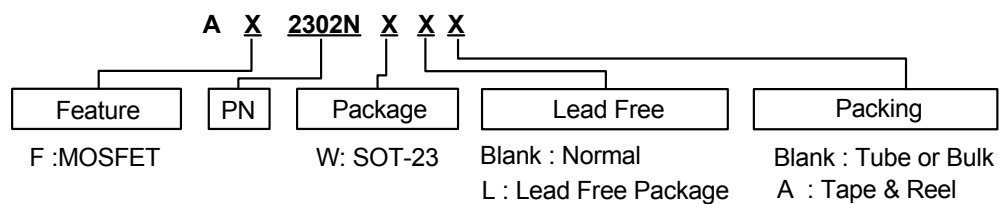

■ Block Diagram

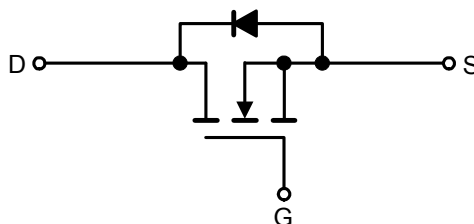



N-Channel Enhancement Mode Power MOSFET

■ Absolute Maximum Ratings

Symbol	Parameter	Rating	Units
V_{DS}	Drain-Source Voltage	20	V
V_{GS}	Gate-Source Voltage	± 12	V
I_D	Continuous Drain Current, $V_{GS}=4.5V$ (Note 1)	$T_A=25^\circ C$	3.2
		$T_A=70^\circ C$	2.6
I_{DM}	Pulsed Drain Current (Note 2, 3)	10	A
P_D	Total Power Dissipation	$T_A=25^\circ C$	1.38
	Linear Derating Factor		0.01
T_{STG}	Storage Temperature Range	-55 to +150	$^\circ C$
T_J	Operating Junction Temperature Range	-55 to +150	$^\circ C$

■ Thermal Data

Symbol	Parameter	Limit	Units
$R_{\theta JA}$	Thermal Resistance Junction-Ambient (Note 1) Max.	90	$^\circ C/W$

■ Electrical Characteristics ($T_J=25^\circ C$ unless otherwise specified)

Symbol	Parameter	Test Conditions	Limits			Unit
			Min.	Typ.	Max.	
BV_{DSS}	Drain-Source Breakdown Voltage	$V_{GS}=0V, I_D=250\mu A$	20	-	-	V
$\frac{\Delta BV_{DSS}}{\Delta T_J}$	Breakdown Voltage Temperature Coefficient	Reference to $25^\circ C$, $I_D=1mA$	-	0.1	-	$V/^\circ C$
$R_{DS(ON)}$	Static Drain-Source On-Resistance (Note 3)	$V_{GS}=4.5V, I_D=3.6A$	-	-	85	m Ω
		$V_{GS}=2.5V, I_D=3.1A$	-	-	115	
$V_{GS(th)}$	Gate Threshold Voltage	$V_{DS}=V_{GS}, I_D=250\mu A$	0.5	-	1.2	V
g_{fs}	Forward Transconductance	$V_{DS}=5V, I_D=3.6A$	-	6	-	S
I_{DSS}	Drain-Source Leakage Current	$T_J=25^\circ C$	-	-	1	μA
		$T_J=70^\circ C$	-	-	10	
I_{GSS}	Gate-Source Leakage	$V_{GS}=\pm 12V$	-	-	± 100	nA
Q_g	Total Gate Charge (Note 3)	$V_{DS}=10V, I_D=3.6A,$ $V_{GS}=4.5V$	-	4.4	-	nC
Q_{gs}	Gate-Source Charge		-	0.6	-	
Q_{gd}	Gate-Drain ("Miller") Charge		-	1.9	-	
$t_{d(on)}$	Turn-On Delay Time (Note 3)	$V_{DS}=10V, R_D=2.8\Omega,$ $I_D=3.6A, V_{GS}=5V,$ $R_G=6\Omega$	-	5.2	-	nS
t_r	Turn-On Rise Time		-	37	-	
$t_{d(off)}$	Turn-Off Delay Time		-	15	-	
t_f	Turn-Off Fall-Time		-	5.7	-	
C_{iss}	Input Capacitance	$V_{DS}=10V, V_{GS}=0V,$ $f=1.0MHz$	-	145	-	pF
C_{oss}	Output Capacitance		-	100	-	
C_{rss}	Reverse Transfer Capacitance		-	50	-	

■ Source-Drain Diode

Symbol	Parameter	Test Conditions	Min.	Typ.	Max.	Unit
I_S	Continuous Source Current (Body Diode)	$V_D=V_G=0V, V_S=1.2V$	-	-	1	A
I_{SM}	Pulsed Source Current (Body Diode) (Note 2)		-	-	10	A
V_{SD}	Forward On Voltage (Note 3)	$I_S=1.6A, V_{GS}=0V$	-	-	1.2	V

Note 1: Surface mounted on 1 in² copper pad of FR4 board; 270 $^\circ C/W$ when mounted on min. copper pad.

Note 2: Pulse width limited by Max. junction temperature.

Note 3: Pulse width $\leq 300\mu s$, duty cycle $\leq 2\%$.

N-Channel Enhancement Mode Power MOSFET

■ Typical Performance Characteristics

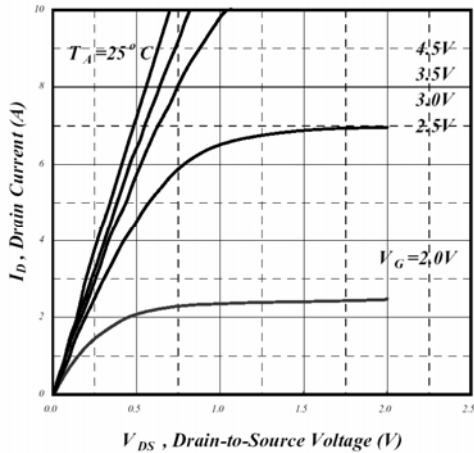

Fig 1. Typical Output Characteristics

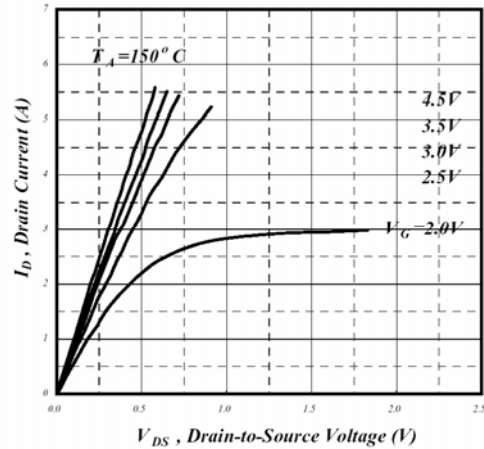

Fig 2. Typical Output Characteristics

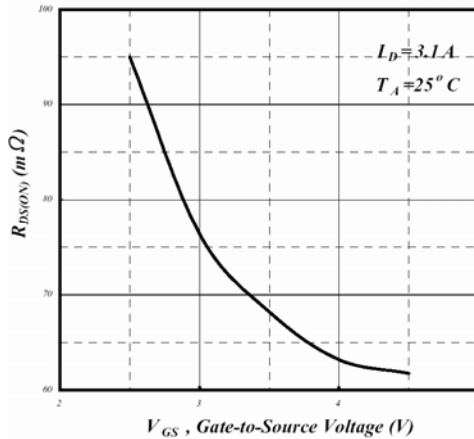

Fig 3. On-Resistance v.s. Gate Voltage

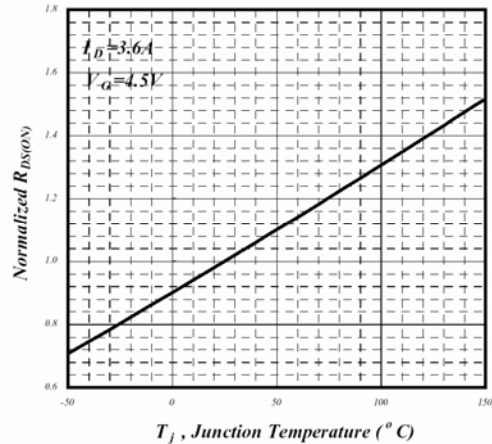

Fig 4. Normalized On-Resistance v.s. Junction Temperature

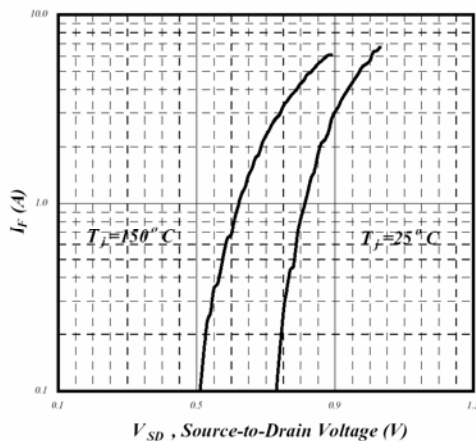

Fig 5. Forward Characteristic of Reverse Diode

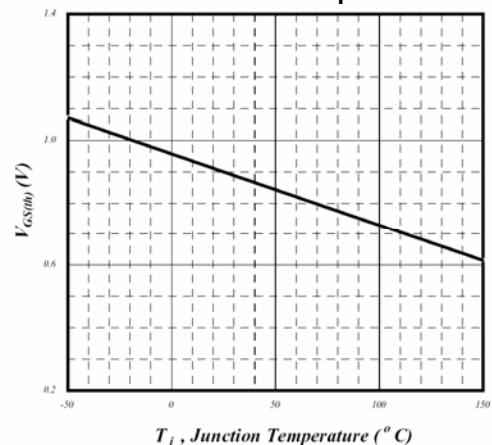

Fig 6. Gate Threshold Voltage v.s. Junction Temperature

N-Channel Enhancement Mode Power MOSFET

■ Typical Performance Characteristics (Continued)

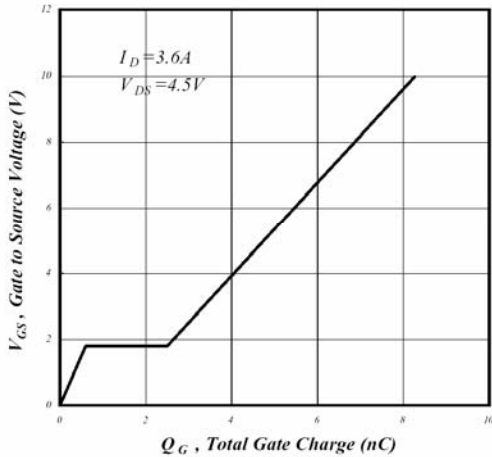

Fig 7. Gate Charge Characteristics

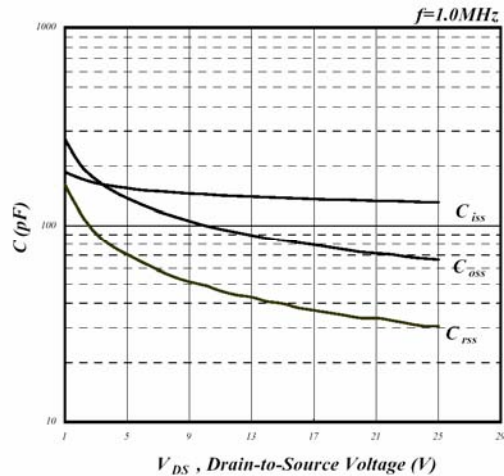

Fig 8. Typical Capacitance Characteristics

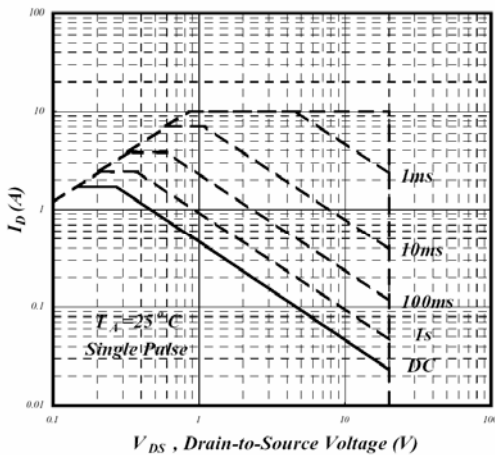

Fig 9. Maximum Safe Operating Area

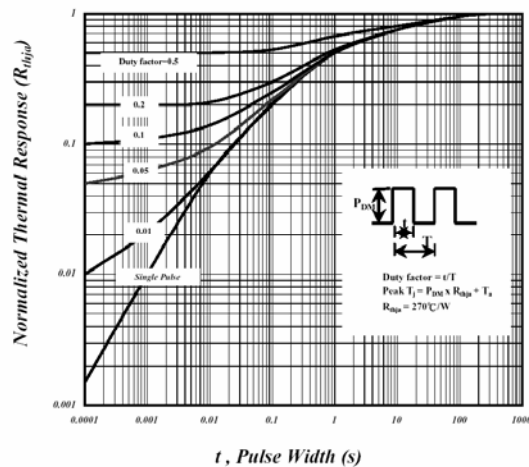

Fig 10. Effective Transient Thermal Impedance

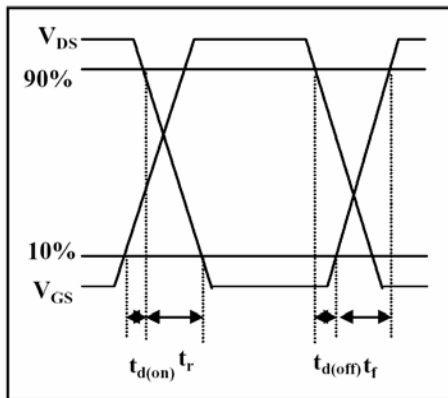

Fig 11. Switching Time Waveform

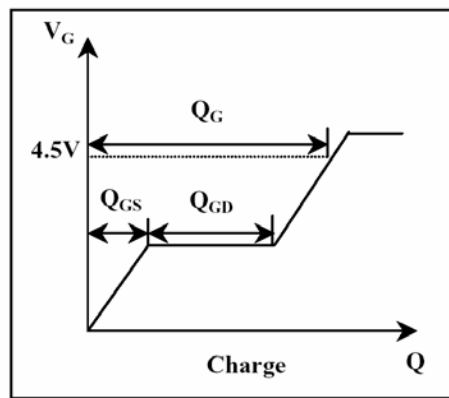
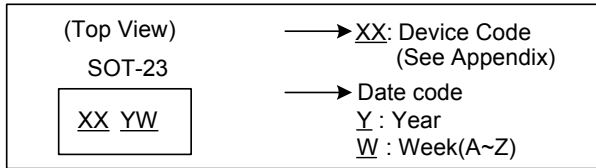

Fig 12. Gate Charge Waveform

N-Channel Enhancement Mode Power MOSFET

■ Marking Information



Appendix

Part Number	Package	Device Code
AF2302N	SOT-23	02

■ Package Information

Package Type: SOT-23

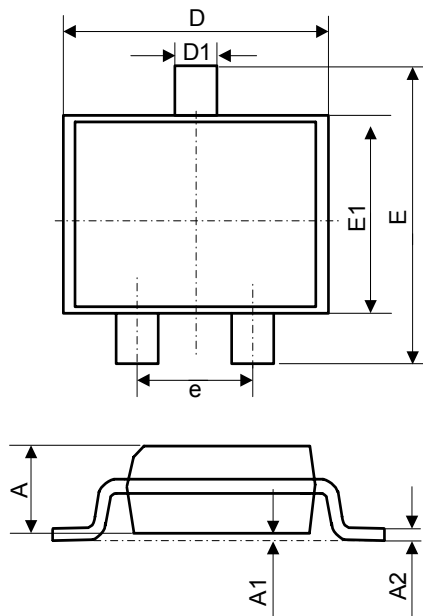

1. All Dimensions Are in Millimeters.
2. Dimension Does Not Include Mold Protrusions.

Symbol	Dimensions In Millimeters		
	Min.	Nom.	Max.
A	1.00	1.15	1.30
A1	0.00	-	0.10
A2	0.10	0.15	0.20
D	2.70	2.90	3.10
D1	0.30	0.40	0.50
e	1.70	2.00	2.30
E	2.40	2.65	2.90
E1	1.40	1.50	1.60