



Peak EMI Reducing Solution

Features

- FCC approved method of EMI attenuation.
- Generates a 1X low EMI spread spectrum clock of the input frequency.
- Input frequency range: 12MHz to 22MHz.
- Internal loop filter minimizes external components and board space.
- Frequency deviation: - 0.8%(Typ) @ 20MHz.
- Low cycle-to-cycle jitter.
- 5.0V \pm 5% operating voltage range.
- TTL or CMOS compatible outputs.
- Available in 8-pin TSSOP and SOIC package.

Product Description

The ASM3P2107A is a versatile spread spectrum frequency modulator designed specifically for input clock frequencies from 12MHz to 22MHz. The ASM3P2107A can generate an EMI reduced clock from crystal, ceramic resonator, or system clock.

The ASM3P2107A reduces electromagnetic interference (EMI) at the clock source, allowing system wide reduction of EMI of down stream clock and data dependent signals. The ASM3P2107A allows significant system cost savings

by reducing the number of circuit board layers ferrite beads, shielding and other passive components that are traditionally required to pass EMI regulations.

The ASM3P2107A uses the most efficient and optimized modulation profile approved by the FCC and is implemented in a proprietary all digital method.

The ASM3P2107A modulates the output of a single PLL in order to “spread” the bandwidth of a synthesized clock, and more importantly, decreases the peak amplitudes of its harmonics. This results in significantly lower system EMI compared to the typical narrow band signal produced by oscillators and most frequency generators. Lowering EMI by increasing a signal’s bandwidth is called ‘spread spectrum clock generation.’

Applications

The ASM3P2107A is targeted towards EMI management for high speed digital applications such as PC peripheral devices, consumer electronics and embedded controller systems.

Block Diagram

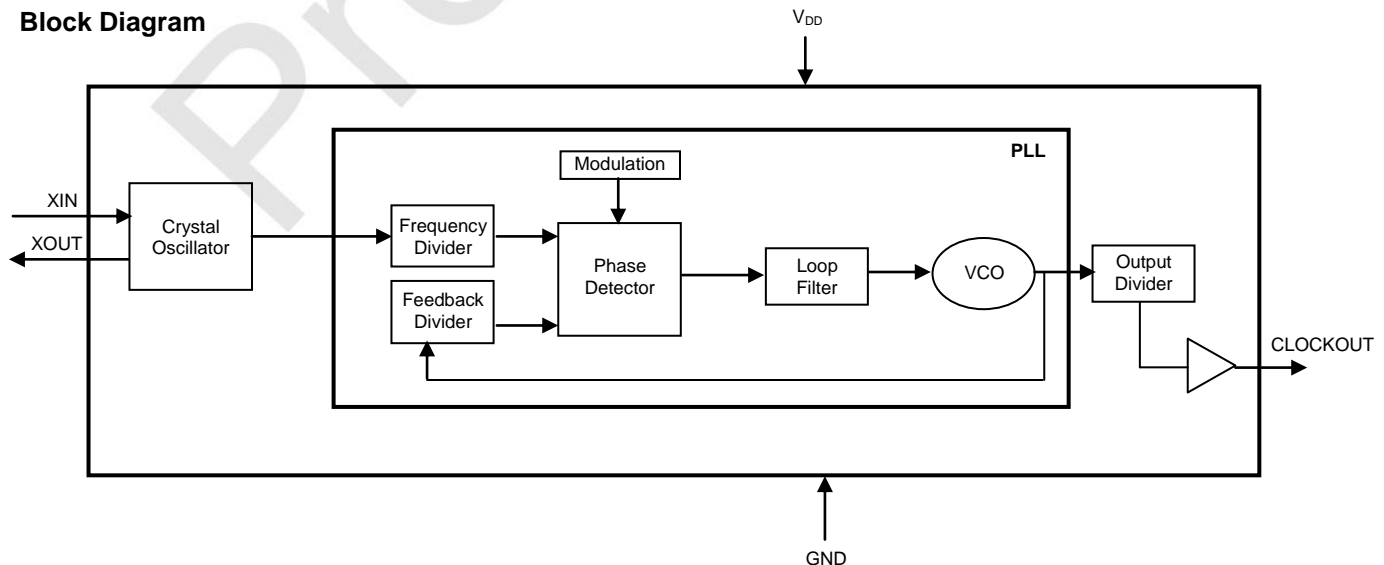

Pin Configuration

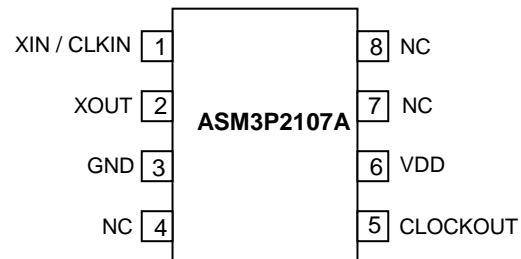

Pin Description

Pin#	Pin Name	Type	Description
1	XIN / CLKIN	I	Crystal connection or external reference frequency input. This pin has dual functions. It can be connected to either an external crystal or an external reference clock.
2	XOUT	O	Crystal connection. If using an external reference, this pin must be left unconnected.
3	GND	P	Ground to entire chip.
4	NC	-	No connect.
5	CLOCKOUT	O	Spread spectrum low EMI output.
6	VDD	P	Power supply for the entire chip (5V).
7	NC	-	No connect.
8	NC	-	No connect.

Absolute Maximum Ratings

Symbol	Parameter	Rating	Unit
V_{DD}, V_{IN}	Voltage on any pin with respect to Ground	-0.5 to +7.0	V
T_{STG}	Storage temperature	-65 to +125	°C
T_A	Operating temperature	0 to 70	°C
T_s	Max. Soldering Temperature (10 sec)	260	°C
T_J	Junction Temperature	150	°C
T_{DV}	Static Discharge Voltage (As per JEDEC STD22- A114-B)	2	KV

Note: These are stress ratings only and are not implied for functional use. Exposure to absolute maximum ratings for prolonged periods of time may affect device reliability.

DC Electrical Characteristics

Symbol	Parameter	Min	Typ	Max	Unit
V _{IL}	Input low voltage	GND – 0.3	-	0.8	V
V _{IH}	Input high voltage	2.0	-	V _{DD} + 0.3	V
I _{IL}	Input low current	-	44	-	μA
I _{IH}	Input high current	-	66	-	μA
I _{XOL}	X _{OUT} output low current (@ 0.4, V _{DD} = 5V)	-	3	-	mA
I _{XOH}	X _{OUT} output high current (@2.5V, V _{DD} = 5V)	-	3	-	mA
V _{OL}	Output low voltage (V _{DD} = 5V, I _{OL} = 20mA)	-	-	0.4	V
V _{OH}	Output high voltage (V _{DD} = 5V, I _{OH} = 20mA)	2.5	-	-	V
I _{CC}	Dynamic supply current normal mode (5V, 18MHz and 15pF loading)	-	40	-	mA
I _{DD}	Static supply current standby mode	-	40	-	μA
V _{DD}	Operating voltage	4.75	5.0	5.25	V
t _{ON}	Power up time (first locked clock cycle after power up)	-	0.18	-	mS
Z _{OUT}	Clock out impedance	-	50	-	Ω

AC Electrical Characteristics

Symbol	Parameter	Min	Typ	Max	Unit	
f _{IN}	Input frequency	12	-	22	MHz	
MODOUT	Output frequency	12	-	22	MHz	
f _d	Frequency Deviation	Input Frequency = 12MHz	-	-2.13	-	%
		Input Frequency = 22MHz	-	-0.62	-	
t _{LH} *	Output rise time (measured at 0.8V to 2.0V)	-	440	-	pS	
t _{HL} *	Output fall time (measured at 2.0V to 0.8V)	-	300	-	pS	
t _{JC}	Jitter (cycle to cycle)	-	-	360	pS	
t _D	Output duty cycle	45	50	55	%	

* V_{DD} = +5V, Input Frequency = 18MHz, t_{LH} and t_{HL} are measured into a capacitive load of 15pF

Package Information

8-Pin SOIC Package

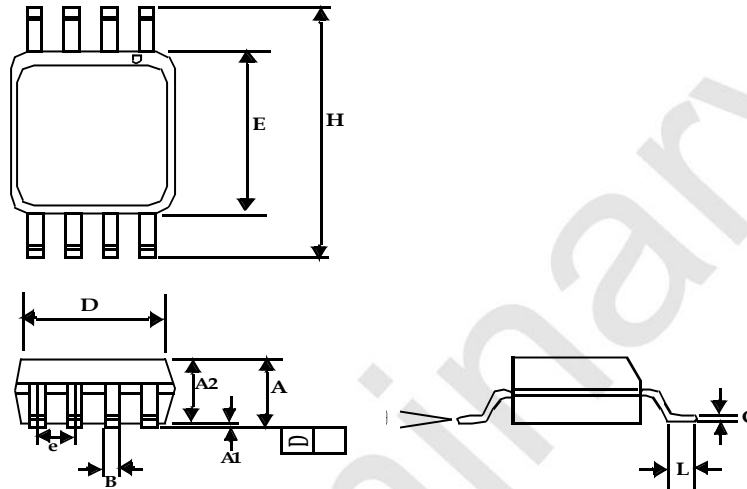

Symbol	Dimensions			
	Inches		Millimeters	
	Min	Max	Min	Max
A1	0.004	0.010	0.10	0.25
A	0.053	0.069	1.35	1.75
A2	0.049	0.059	1.25	1.50
B	0.012	0.020	0.31	0.51
C	0.007	0.010	0.18	0.25
D	0.193 BSC		4.90 BSC	
E	0.154 BSC		3.91 BSC	
e	0.050 BSC		1.27 BSC	
H	0.236 BSC		6.00 BSC	
L	0.016	0.050	0.41	1.27
θ	0°	8°	0°	8°

8-Pin TSSOP

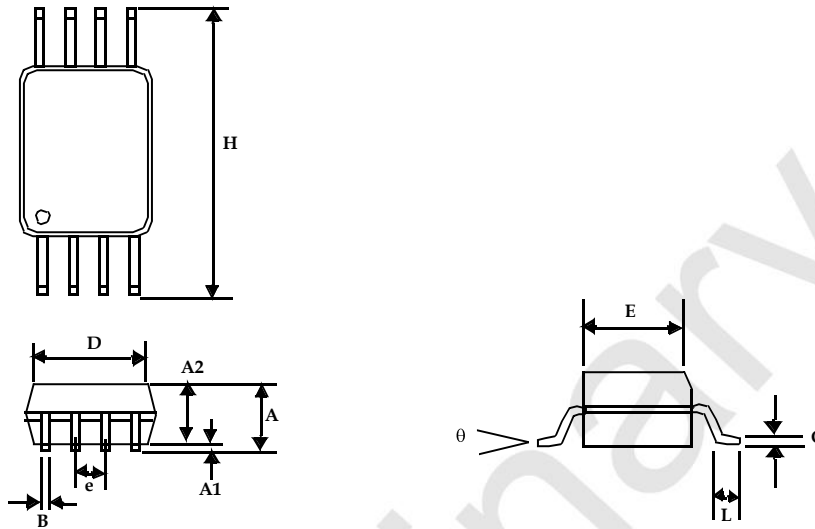

Symbol	Dimensions			
	Inches		Millimeters	
	Min	Max	Min	Max
A		0.043		1.10
A1	0.002	0.006	0.05	0.15
A2	0.033	0.037	0.85	0.95
B	0.008	0.012	0.19	0.30
c	0.004	0.008	0.09	0.20
D	0.114	0.122	2.90	3.10
E	0.169	0.177	4.30	4.50
e	0.026 BSC		0.65 BSC	
H	0.252 BSC		6.40 BSC	
L	0.020	0.028	0.50	0.70
θ	0°	8°	0°	8°

Ordering Codes

Part Number	Marking	Package	Temperature
ASM3P2107AF-08-SR	3P2107AF	8-PIN SOIC, TAPE AND REEL, Pb Free	Commercial
ASM3P2107AF-08-ST	3P2107AF	8-PIN SOIC, TUBE, Pb Free	Commercial
ASM3P2107AF-08-TR	3P2107AF	8-PIN TSSOP, TAPE AND REEL, Pb Free	Commercial
ASM3P2107AF-08-TT	3P2107AF	8-PIN TSSOP, TUBE, Pb Free	Commercial
ASM3P2107AG-08-SR	3P2107AG	8-PIN SOIC, TAPE AND REEL, Green	Commercial
ASM3P2107AG-08-ST	3P2107AG	8-PIN SOIC, TUBE, Green	Commercial
ASM3P2107AG-08-TR	3P2107AG	8-PIN TSSOP, TAPE AND REEL, Green	Commercial
ASM3P2107AG-08-TT	3P2107AG	8-PIN TSSOP, TUBE, Green	Commercial

Device Ordering Information

A S M 3 P 2 1 0 7 A G - 0 8 - S T

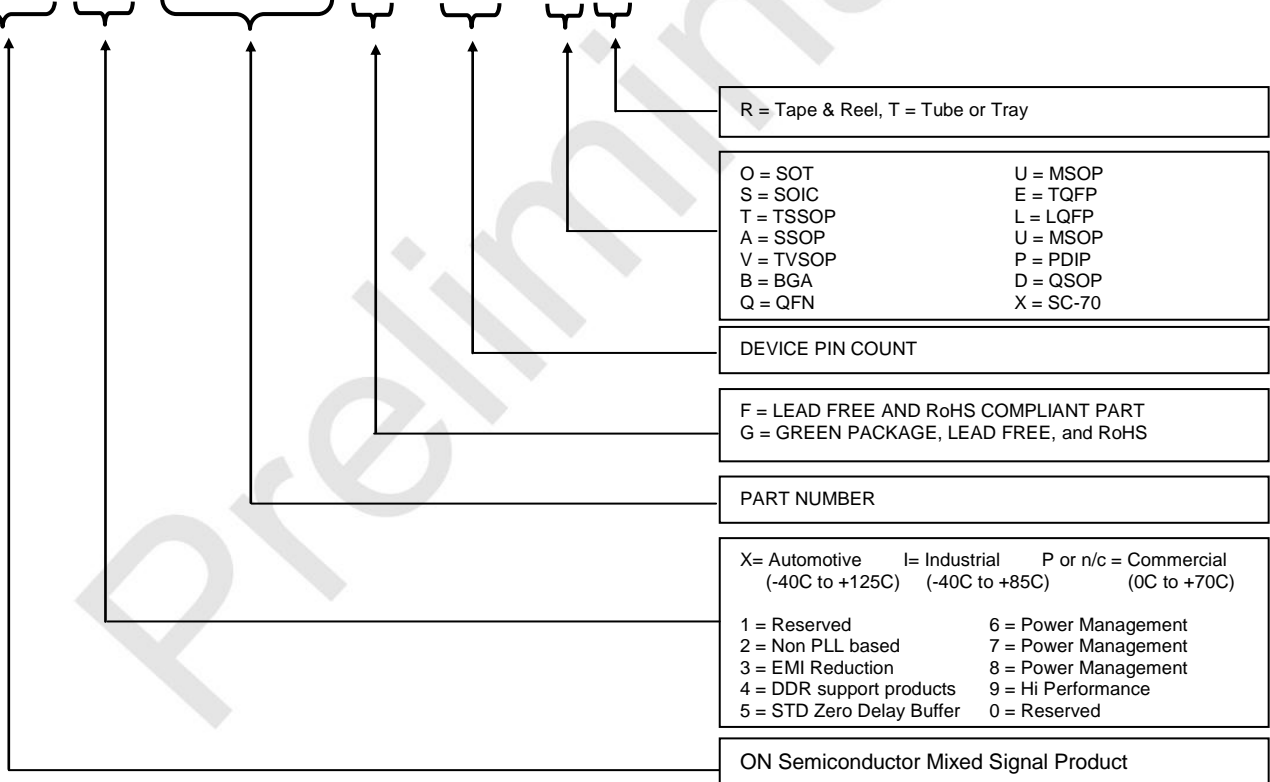

Licensed under US patent #5,488,627, #6,646,463 and #5,631,920.

Note: This product utilizes US Patent # 6,646,463 Impedance Emulator Patent issued to PulseCore Semiconductor, dated 11-11-2003

ON Semiconductor and  are registered trademarks of Semiconductor Components Industries, LLC (SCILLC). SCILLC reserves the right to make changes without further notice to any products herein. SCILLC makes no warranty, representation or guarantee regarding the suitability of its products for any particular purpose, nor does SCILLC assume any liability arising out of the application or use of any product or circuit, and specifically disclaims any and all liability, including without limitation special, consequential or incidental damages. "Typical" parameters which may be provided in SCILLC data sheets and/or specifications can and do vary in different applications and actual performance may vary over time. All operating parameters, including "Typicals" must be validated for each customer application by customer's technical experts. SCILLC does not convey any license under its patent rights nor the rights of others. SCILLC products are not designed, intended, or authorized for use as components in systems intended for surgical implant into the body, or other applications intended to support or sustain life, or for any other application in which the failure of the SCILLC product could create a situation where personal injury or death may occur. Should Buyer purchase or use SCILLC products for any such unintended or unauthorized application, Buyer shall indemnify and hold SCILLC and its officers, employees, subsidiaries, affiliates, and distributors harmless against all claims, costs, damages, and expenses, and reasonable attorney fees arising out of, directly or indirectly, any claim of personal injury or death associated with such unintended or unauthorized use, even if such claim alleges that SCILLC was negligent regarding the design or manufacture of the part. SCILLC is an Equal Opportunity/Affirmative Action Employer. U.S. Patent Pending; Timing-Safe and Active Bead are trademarks of PulseCore Semiconductor, a wholly owned subsidiary of ON Semiconductor. This literature is subject to all applicable copyright laws and is not for resale in any manner.

PUBLICATION ORDERING INFORMATION**LITERATURE FULFILLMENT:**

Literature Distribution Center for ON Semiconductor
P.O. Box 5163, Denver, Colorado 80217 USA
Phone: 303-675-2175 or 800-344-3860 Toll Free
USA/Canada
Fax: 303-675-2176 or 800-344-3867 Toll Free
USA/Canada
Email: orderlit@onsemi.com

N. American Technical Support: 800-282-9855
Toll Free USA/Canada
Europe, Middle East and Africa Technical Support:
Phone: 421 33 790 2910
Japan Customer Focus Center
Phone: 81-3-5773-3850

ON Semiconductor Website:
www.onsemi.com

Order Literature: <http://www.onsemi.com/orderlit>

For additional information, please contact your local Sales Representative